

Kawasaki Ninja ZX-12R

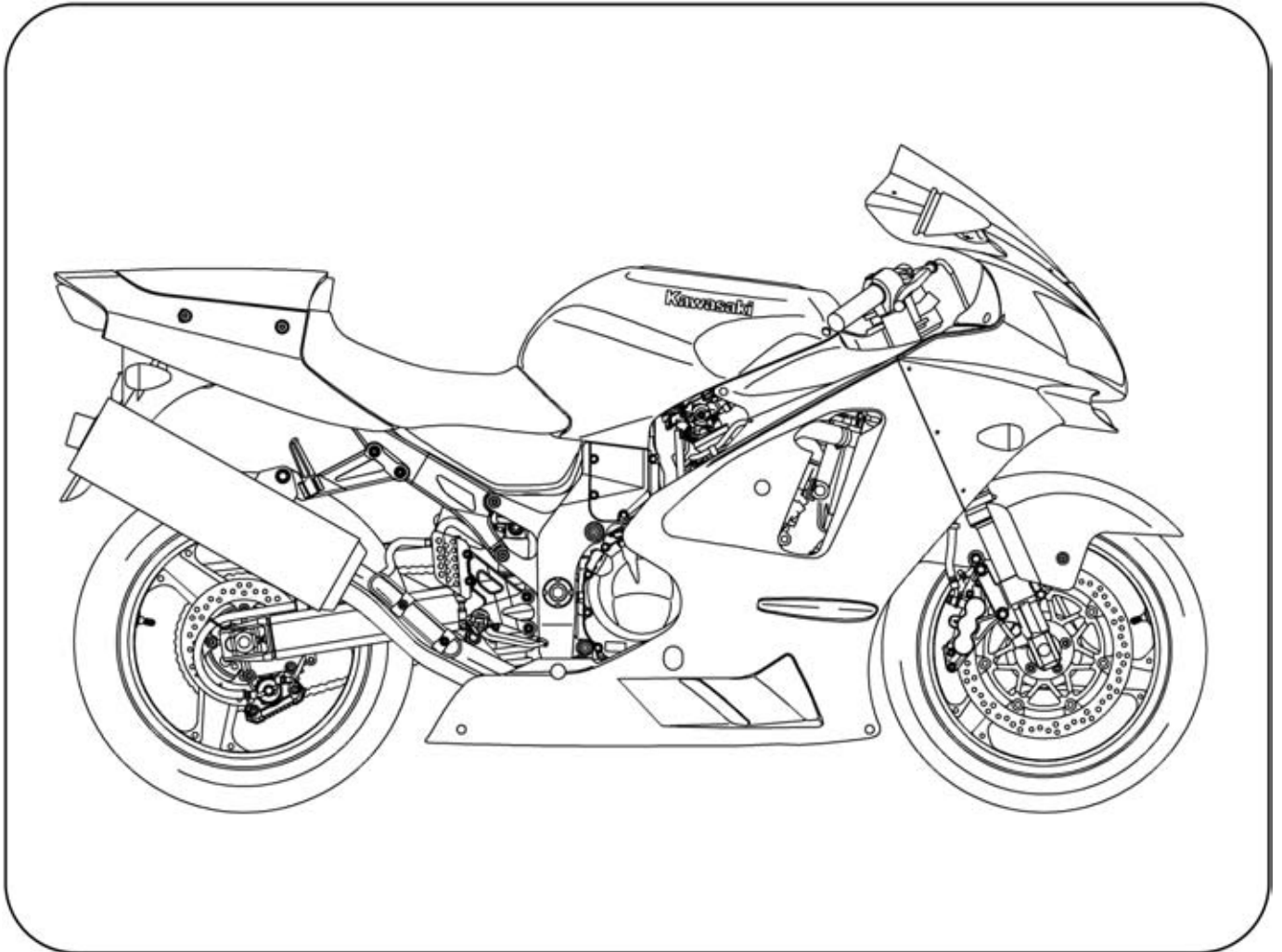

Motorcycle Service Manual

Quick Reference Guide

General Information	1
Periodic Maintenance	2
Fuel System (DFI)	3
Cooling System	4
Engine Top End	5
Clutch	6
Engine Lubrication System	7
Engine Removal/Installation	8
Crankshaft/Transmission	9
Wheels/Tires	10
Final Drive	11
Brakes	12
Suspension	13
Steering	14
Frame	15
Electrical System	16
Troubleshooting	17

This quick reference guide will assist you in locating a desired topic or procedure.

- Bend the pages back to match the black tab of the desired chapter number with the black tab on the edge at each table of contents page.
- Refer to the sectional table of contents for the exact pages to locate the specific topic required.

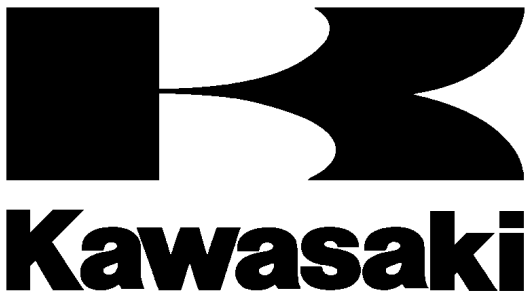

Ninja ZX-12R

Motorcycle Service Manual

All rights reserved. No parts of this publication may be reproduced, stored in a retrieval system, or transmitted in any form or by any means, electronic mechanical photocopying, recording or otherwise, without the prior written permission of Quality Assurance Department/Consumer Products & Machinery Company/Kawasaki Heavy Industries, Ltd., Japan.

No liability can be accepted for any inaccuracies or omissions in this publication, although every possible care has been taken to make it as complete and accurate as possible.

The right is reserved to make changes at any time without prior notice and without incurring an obligation to make such changes to products manufactured previously. See your Motorcycle dealer for the latest information on product improvements incorporated after this publication.

All information contained in this publication is based on the latest product information available at the time of publication. Illustrations and photographs in this publication are intended for reference use only and may not depict actual model component parts.

LIST OF ABBREVIATIONS

A	ampere(s)	lb	pound(s)
ABDC	after bottom dead center	m	meter(s)
AC	alternating current	min	minute(s)
ATDC	after top dead center	N	newton(s)
BBDC	before bottom dead center	Pa	pascal(s)
BDC	bottom dead center	PS	horsepower
BTDC	before top dead center	psi	pound(s) per square inch
°C	degree(s) Celsius	r	revolution
DC	direct current	rpm	revolution(s) per minute
F	farad(s)	TDC	top dead center
°F	degree(s) Fahrenheit	TIR	total indicator reading
ft	foot, feet	V	volt(s)
g	gram(s)	W	watt(s)
h	hour(s)	Ω	ohm(s)
L	liter(s)		

Read OWNER'S MANUAL before operating.

EMISSION CONTROL INFORMATION

To protect the environment in which we all live, Kawasaki has incorporated crankcase emission (1) and exhaust emission (2) control systems in compliance with applicable regulations of the United States Environmental Protection Agency and California Air Resources Board. Additionally, Kawasaki has incorporated an evaporative emission control system (3) in compliance with applicable regulations of the California Air Resources Board on vehicles sold in California only.

1. Crankcase Emission Control System

This system eliminates the release of crankcase vapors into the atmosphere. Instead, the vapors are routed through an oil separator to the inlet side of the engine. While the engine is operating, the vapors are drawn into combustion chamber, where they are burned along with the fuel and air supplied by the fuel injection system.

2. Exhaust Emission Control System

This system reduces the amount of pollutants discharged into the atmosphere by the exhaust of this motorcycle. The fuel, ignition, and exhaust systems of this motorcycle have been carefully designed and constructed to ensure an efficient engine with low exhaust pollutant levels.

The exhaust system of this model motorcycle manufactured primarily for sale in California includes a catalytic converter system.

3. Evaporative Emission Control System

Vapors caused by fuel evaporation in the fuel system are not vented into the atmosphere. Instead, fuel vapors are routed into the running engine to be burned, or stored in a canister when the engine is stopped. Liquid fuel is caught by a vapor separator and returned to the fuel tank.

The Clean Air Act, which is the Federal law covering motor vehicle pollution, contains what is commonly referred to as the Act's "tampering provisions."

"Sec. 203(a) The following acts and the causing thereof are prohibited...

(3)(A) for any person to remove or render inoperative any device or element of design installed on or in a motor vehicle or motor vehicle engine in compliance with regulations under this title prior to its sale and delivery to the ultimate purchaser, or for any manufacturer or dealer knowingly to remove or render inoperative any such device or element of design after such sale and delivery to the ultimate purchaser.

(3)(B) for any person engaged in the business of repairing, servicing, selling, leasing, or trading motor vehicles or motor vehicle engines, or who operates a fleet of motor vehicles knowingly to remove or render inoperative any device or element of design installed on or in a motor vehicle or motor vehicle engine in compliance with regulations under this title following its sale and delivery to the ultimate purchaser..."

NOTE

○The phrase "remove or render inoperative any device or element of design" has been generally interpreted as follows:

1. Tampering does not include the temporary removal or rendering inoperative of devices or elements of design in order to perform maintenance.
2. Tampering could include:
 - a. Maladjustment of vehicle components such that the emission standards are exceeded.
 - b. Use of replacement parts or accessories which adversely affect the performance or durability of the motorcycle.
 - c. Addition of components or accessories that result in the vehicle exceeding the standards.
 - d. Permanently removing, disconnecting, or rendering inoperative any component or element of design of the emission control systems.

WE RECOMMEND THAT ALL DEALERS OBSERVE THESE PROVISIONS OF FEDERAL LAW, THE VIOLATION OF WHICH IS PUNISHABLE BY CIVIL PENALTIES NOT EXCEEDING \$10,000 PER VIOLATION.

TAMPERING WITH NOISE CONTROL SYSTEM PROHIBITED

Federal law prohibits the following acts or the causing thereof: (1) The removal or rendering inoperative by any person other than for purposes of maintenance, repair, or replacement, of any device or element of design incorporated into any new vehicle for the purpose of noise control prior to its sale or delivery to the ultimate purchaser or while it is in use, or (2) the use of the vehicle after such device or element of design has been removed or rendered inoperative by any person.

Among those acts presumed to constitute tampering are the acts listed below:

- Replacement of the original exhaust system or muffler with a component not in compliance with Federal regulations.
- Removal of the muffler(s) or any internal portion of the muffler(s).
- Removal of the air box or air box cover.
- Modifications to the muffler(s) or air inlet system by cutting, drilling, or other means if such modifications result in increased noise levels.

Foreword

This manual is designed primarily for use by trained mechanics in a properly equipped shop. However, it contains enough detail and basic information to make it useful to the owner who desires to perform his own basic maintenance and repair work. A basic knowledge of mechanics, the proper use of tools, and workshop procedures must be understood in order to carry out maintenance and repair satisfactorily. Whenever the owner has insufficient experience or doubts his ability to do the work, all adjustments, maintenance, and repair should be carried out only by qualified mechanics.

In order to perform the work efficiently and to avoid costly mistakes, read the text, thoroughly familiarize yourself with the procedures before starting work, and then do the work carefully in a clean area. Whenever special tools or equipment are specified, do not use makeshift tools or equipment. Precision measurements can only be made if the proper instruments are used, and the use of substitute tools may adversely affect safe operation.

For the duration of the warranty period, we recommend that all repairs and scheduled maintenance be performed in accordance with this service manual. Any owner maintenance or repair procedure not performed in accordance with this manual may void the warranty.

To get the longest life out of your vehicle:

- Follow the Periodic Maintenance Chart in the Service Manual.
- Be alert for problems and non-scheduled maintenance.
- Use proper tools and genuine Kawasaki Motorcycle parts. Special tools, gauges, and testers that are necessary when servicing Kawasaki motorcycles are introduced by the Special Tool Catalog or Manual. Genuine parts provided as spare parts are listed in the Parts Catalog.
- Follow the procedures in this manual carefully. Don't take shortcuts.
- Remember to keep complete records of maintenance and repair with dates and any new parts installed.

How to Use This Manual

In this manual, the product is divided into its major systems and these systems make up the manual's chapters. The Quick Reference

Guide shows you all of the product's system and assists in locating their chapters. Each chapter in turn has its own comprehensive Table of Contents.

For example, if you want ignition coil information, use the Quick Reference Guide to locate the Electrical System chapter. Then, use the Table of Contents on the first page of the chapter to find the Ignition Coil section.

Whenever you see these WARNING and CAUTION symbols, heed their instructions! Always follow safe operating and maintenance practices.

WARNING

This warning symbol identifies special instructions or procedures which, if not correctly followed, could result in personal injury, or loss of life.

CAUTION

This caution symbol identifies special instructions or procedures which, if not strictly observed, could result in damage to or destruction of equipment.

This manual contains four more symbols (in addition to WARNING and CAUTION) which will help you distinguish different types of information.

NOTE

○ *This note symbol indicates points of particular interest for more efficient and convenient operation.*

- Indicates a procedural step or work to be done.
- Indicates a procedural sub-step or how to do the work of the procedural step it follows. It also precedes the text of a NOTE.
- ★ Indicates a conditional step or what action to take based on the results of the test or inspection in the procedural step or sub-step it follows.

In most chapters an exploded view illustration of the system components follows the Table of Contents. In these illustrations you will find the instructions indicating which parts require specified tightening torque, oil, grease or a locking agent during assembly.

General Information

1

Table of Contents

Before Servicing	1-2
Model Identification.....	1-5
General Specifications.....	1-6
Technical Information – KAWASAKI LOW EXHAUST EMISSION SYSTEM	1-9
Technical Information – Monocoque Frame	1-12
Technical Information – Spark Plug	1-13
Technical Information – Immobilizer System (ZX1200-B3).....	1-14
Torque and Locking Agent.....	1-17
Special Tools and Sealant	1-22
Cable, Wire, and Hose Routing (ZX1200-B1/B2).....	1-29
Cable, Wire, and Hose Routing (ZX1200-B3)	1-46
Unit Conversion Table	1-60

1-2 GENERAL INFORMATION

Before Servicing

Before starting to service a motorcycle, careful reading of the applicable section is recommended to eliminate unnecessary work. Photographs, diagrams, notes, cautions, warnings, and detailed descriptions have been included wherever necessary. Nevertheless, even a detailed account has limitations, a certain amount of basic knowledge is also required for successful work.

Especially note the following:

(1) Dirt

Before removal and disassembly, clean the motorcycle. Any dirt entering the engine or other parts will work as an abrasive and shorten the life of the motorcycle. For the same reason, before installing a new part, clean off any dust or metal filings.

(2) Battery Cables

Disconnect the ground (–) cable from the battery before performing any disassembly operations on the motorcycle. This prevents the engine from accidentally turning over while work is being carried out, sparks from being generated while disconnecting the leads from electrical parts, as well as damage to the electrical parts themselves. For reinstallation, first connect the positive cable to the positive (+) terminal of the battery.

(3) Installation, Assembly

Generally, installation or assembly is the reverse of removal or disassembly. But if this Service Manual has installation or assembly procedures, follow them. Note parts locations and cable, lead, and hose routing during removal or disassembly so they can be installed or assembled in the same way. It is preferable to mark and record the locations and routing as much as possible.

(4) Tightening Sequence

Generally, when installing a part with several bolts, nuts, or screws, start them all in their holes and tighten them to a snug fit. Then tighten them evenly in a cross pattern. This is to avoid distortion of the part and/or causing gas or oil leakage. Conversely when loosening the bolts, nuts, or screws, first loosen all of them by about a quarter turn and then remove them. Where there is a tightening sequence indication in this Service Manual, the bolts, nuts, or screws must be tightened in the order and method indicated.

(5) Torque

When torque values are given in this Service Manual, use them. Either too little or too much torque may lead to serious damage. Use a good quality, reliable torque wrench.

(6) Force

Common sense should dictate how much force is necessary in assembly and disassembly. If a part seems especially difficult to remove or install, stop and examine what may be causing the problem. Whenever tapping is necessary, tap lightly using a wooden or plastic-faced mallet. Use an impact driver for screws (particularly for the removal of screws held by a locking agent) in order to avoid damaging the screw heads.

(7) Edges

Watch for sharp edges, especially during major engine disassembly and assembly. Protect your hands with gloves or a piece of thick cloth when lifting the engine or turning it over.

(8) High-Flash Point Solvent

A high-flash point solvent is recommended to reduce fire danger. A commercial solvent commonly available in North America is Stoddard solvent (generic name). Always follow manufacturer and container directions regarding the use of any solvent.

(9) Gasket, O-ring

Do not reuse a gasket or O-ring once it has been in service. The mating surfaces around the gasket should be free of foreign matter and perfectly smooth to avoid oil or compression leakage.

(10) Liquid Gasket, Non-Permanent Locking Agent

Follow manufacturer's directions for cleaning and preparing surfaces where these compounds will be used. Apply sparingly. Excessive amounts may block engine oil passages and cause serious damage. An example of non-permanent locking agent commonly available in North America is Loctite Lock'n Seal (Blue).

(11) Press

A part installed using a press or driver, such as a wheel bearing, should first be coated with oil on its outer or inner circumference so that it will go into place smoothly.

Before Servicing

(12)Ball Bearing and Needle Bearing

Do not remove a ball bearing or a needle bearing unless it is absolutely necessary. Replace any ball or needle bearings that were removed with new ones, as removal generally damages bearings. Install bearings with the marked side facing out applying pressure evenly with a suitable driver. Only press on the race that forms the press fit with the base component to avoid damaging the bearings. This prevents severe stress on the balls or needles and races, and prevent races and balls or needles from being dented. Press a ball bearing until it stops at the stopper in the hole or on the shaft.

(13)Oil Seal and Grease Seal

Replace any oil or grease seals that were removed with new ones, as removal generally damages seals. When pressing in a seal which has manufacturer's marks, press it in with the marks facing out. Seals should be pressed into place using a suitable driver, which contacts evenly with the side of seal, until the face of the seal is even with the end of the hole. Before a shaft passes through a seal, apply little high temperature grease on the lips to reduce rubber to metal friction.

(14)Circlip, Retaining Ring, and Cotter Pin

Replace any circlips and retaining rings, and cotter pins that were removed with new ones, as removal weakens and deforms them. When installing circlips and retaining rings, take care to compress or expand them only enough to install them and no more.



(15)Lubrication

Engine wear is generally at its maximum while the engine is warming up and before all the rubbing surfaces have an adequate lubricative film. During assembly, oil or grease (whichever is more suitable) should be applied to any rubbing surface which has lost its lubricative film. Old grease and dirty oil should be cleaned off. Deteriorated grease has lost its lubricative quality and may contain abrasive foreign particles.

Don't use just any oil or grease. Some oils and greases in particular should be used only in certain applications and may be harmful if used in an application for which they are not intended. This manual makes reference to molybdenum disulfide grease (MoS₂) and molybdenum disulfide oil in the assembly of certain engine and chassis parts. The molybdenum disulfide oil is a mixture of engine oil and molybdenum disulfide grease with a weight ratio (10 : 1), which can be made in your work shop. Always check manufacturer recommendations before using such special lubricants.

(16)Electrical Leads

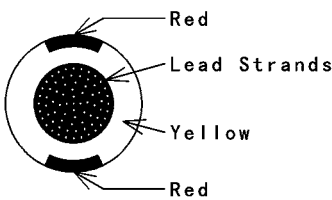
All the electrical leads are either single-color or two-color and, with only a few exceptions, must be connected to leads of the same color. On any of the two-color leads there is a greater amount of one color and a lesser amount of a second color, so a two-color lead is identified by first the primary color and then the secondary color. For example, a yellow lead with thin red stripes is referred to as a "yellow/red" lead; it would be a "red/yellow" lead if the colors were reversed to make red the main color.

Lead (cross-section)	Color Indicated on the Lead	Color Indicated on the Wiring Diagram
	<p>Yellow/Red</p>	

GB02001BW1 C

(17)Replacement Parts

When there is a replacement instruction, replace these parts with new ones every time they are removed. These replacement parts will be damaged or lose their original function once removed.

1-4 GENERAL INFORMATION

Before Servicing

(18) Inspection

When parts have been disassembled, visually inspect these parts for the following conditions or other damage. If there is any doubt as to the condition of them, replace them with new ones.

Abrasion	Crack	Hardening	Warp
Bent	Dent	Scratch	Wear
Color change	Deterioration	Seizure	

(19) Specifications

Specification terms are defined as follows:

"Standards" show dimensions or performances which brand-new parts or systems have.

"Service Limits" indicate the usable limits. If the measurement shows excessive wear or deteriorated performance, replace the damaged parts.

(20) Instrument

Use a meter that has enough accuracy for an accurate measurement.

Read the manufacturer's instructions thoroughly before using the meter.

Incorrect values may lead to improper adjustments.

Model Identification

ZX1200-B1 Left Side View



ZX1200-B1 Right Side View



1-6 GENERAL INFORMATION

General Specifications

Items	ZX1200-B1 ~ B3
Dimensions Overall Length Overall Width Overall Height Wheelbase Road Clearance Seat Height Dry Mass Curb Mass: Front Rear Fuel Tank Capacity	2 085 mm (82.09 in.) 740 mm (29.13 in.) 1 200 mm (47.24 in.) 1 450 mm (57.09 in.) 120 mm (4.72 in.) 820 mm (32.28 in.) 210 kg (463 lb) 125 kg (276 lb) 121 kg (267 lb) 19.0 L (5.0 US gal)
Performance Minimum Turning Radius	3.0 m (9.8 ft)
Engine Type Cooling System Bore and Stroke Displacement Compression Ratio Maximum Horsepower Maximum Torque Carburetion System Starting System Ignition System Timing Advance Ignition Timing Spark Plugs Cylinder Numbering Method Firing Order	4-stroke, DOHC, 4-cylinder Liquid-cooled 83.0 × 55.4 mm (3.27 × 2.18 in.) 1 199 mL (73.16 cu in.) 12.2 (H) 131 kW (178 PS) @9 500 r/min (rpm), (AU) ZX1200-B1/B2: 130 kW (177 PS) @10 500 r/min (rpm), (AU) ZX1200-B3: 131 kW (178 PS) @10 500 r/min (rpm), (HR) 78.2 kW (106.4 PS) @8 500 r/min (rpm), (MY) ZX1200-B1/B2: 131 kW (178 PS) @ 9 500 r/min (rpm), (MY) ZX1200-B3: 128 kW (174 PS) @9 500 r/min (rpm) (US), (CA) – – – (H, AU) 134 N·m (13.7 kgf·m, 99 ft·lb) @7 500 r/min (rpm), (MY) ZX1200-B1/B2: 134 N·m (13.7 kgf·m, 99 ft·lb) @7 500 r/min (rpm), (MY) ZX1200-B3: 130 N·m (13.3 kgf·m, 96 ft·lb) @7 500 r/min (rpm), (HR) 111 N·m (11.3 kgf·m, 82 ft·lb) @5 000 r/min (rpm), (US), (CA) – – – FI (Fuel Injection), ZX1200-B1/B2: MIKUNI 46 EIS × 4 ZX1200-B3: KEIHIN (φ46 × 4) Electric starter Battery and coil (transistorized) Electronically advanced (digital igniter in ECU) 10° BTDC @1 000 r/min (rpm) NGK CR9EKPA Left to right, 1-2-3-4 1-2-4-3

General Specifications

Items	ZX1200-B1 ~ B3
Valve Timing: Inlet: Open Close Duration Exhaust: Open Close Duration Lubrication System Engine Oil: Grade Viscosity Capacity	46° BTDC 74° ABDC 300° 69° BBDC 45° ATDC 294° Forced lubrication (wet sump with cooler) API SE, SF or SG API SH or SJ with JASO MA SAE 10W-40 3.6 L (3.8 US qt)
Drive Train Primary Reduction System: Type Reduction Ratio Clutch Type Transmission: Type Gear Ratios: 1st 2nd 3rd 4th 5th 6th Final Drive System: Type Reduction Ratio Overall Drive Ratio	Gear 1.596 (83/52) Wet, multi disc 6-speed, constant mesh, return shift 2.429 (34/14) 1.824 (31/17) 1.440 (36/25) 1.250 (30/24) 1.130 (26/23) 1.033 (31/30) Chain drive 2.556 (46/18) 4.215 @Top gear
Frame Type Caster (Rake Angle) Trail Front Tire: Type Size Rear Tire: Type Size	Press backbone 23.5° 98 mm (3.86 in.) Tubeless 120/70 ZR17 M/C (58W) Tubeless 200/50 ZR17 M/C (75W)

1-8 GENERAL INFORMATION

General Specifications

Items	ZX1200-B1 ~ B3
Front Suspension: Type Wheel Travel Rear Suspension: Type Wheel Travel Brake Type: Front Rear	Telescopic fork (upside-down) 120 mm (4.72 in.) Swingarm (uni-trak) 140 mm (5.51 in.) Dual discs Single disc
Electrical Equipment Battery Headlight: Type Bulb Tail/Brake Light Alternator: Type Rated Output	12 V 12 Ah Semi-sealed beam 12 V 60/55 W (quartz-halogen) × 2 12 V 5/21 W × 2 Three-phase AC 31 A/14 V @5 000 r/min (rpm)

Specifications are subject to change without notice, and may not apply to every country.

AU: Australian Model

US: U.S.A. Model

CA: Canadian Model

MY: Malaysian Model

HR: WVTA Approval Model, Honeycomb Catalytic Converter (Restricted Power)

H: WVTA Approval Model, Honeycomb Catalytic Converter

Technical Information – KAWASAKI LOW EXHAUST EMISSION SYSTEM

Since the emission regulations become more severe, Kawasaki has adopted a type of simplified KAWASAKI LOW EXHAUST EMISSION SYSTEM (KLEEN), which have no catalyst protection system, according to each regulation of different countries.

The muffler with built-in catalyst has the same durability as the conventional muffler, however, do not use leaded gasoline and do not coast with the ignition system OFF. Running the engine without ignition damages catalyst.

Refer to the ZX900E Service Manual (Part No. 99924-1255) for more information about the KLEEN (theory, maintenance, and handling precautions), including the secondary air injection system.

Honeycomb Type Catalytic Converter

- The converter is a three-way catalytic converter, and its surface is covered with alumina upon which platinum and rhodium are applied, and has a cylindrical metallic honeycomb structure made by bending a corrugated sheet and a flat sheet of stainless steel into a spiral of increasing diameter. The honeycomb structure is convenient for the catalytic converter because it has a large surface area but small size to react effectively and has low exhaust resistance. In addition, its inherent strength helps resist vibration, and has simple structure welded directly on the silencer.
- Generally, the temperature of the exhaust gas must be higher than activation temperature, so the converters are installed in the exhaust manifold rear end where the temperature of exhaust gas is still high. And, the converters will be activated even under low load conditions.
- After the exhaust gas is diluted with the secondary air injection, the catalytic converter works well because of rich oxygen to reduce CO, HC, and NO_x. Accordingly, we can keep the exhaust gas emission within regulation.
- This type of converter works more efficiently as a three-way catalytic converter to reduce CO, HC, and NO_x than the pipe type catalytic converter because of its more and denser catalysts.

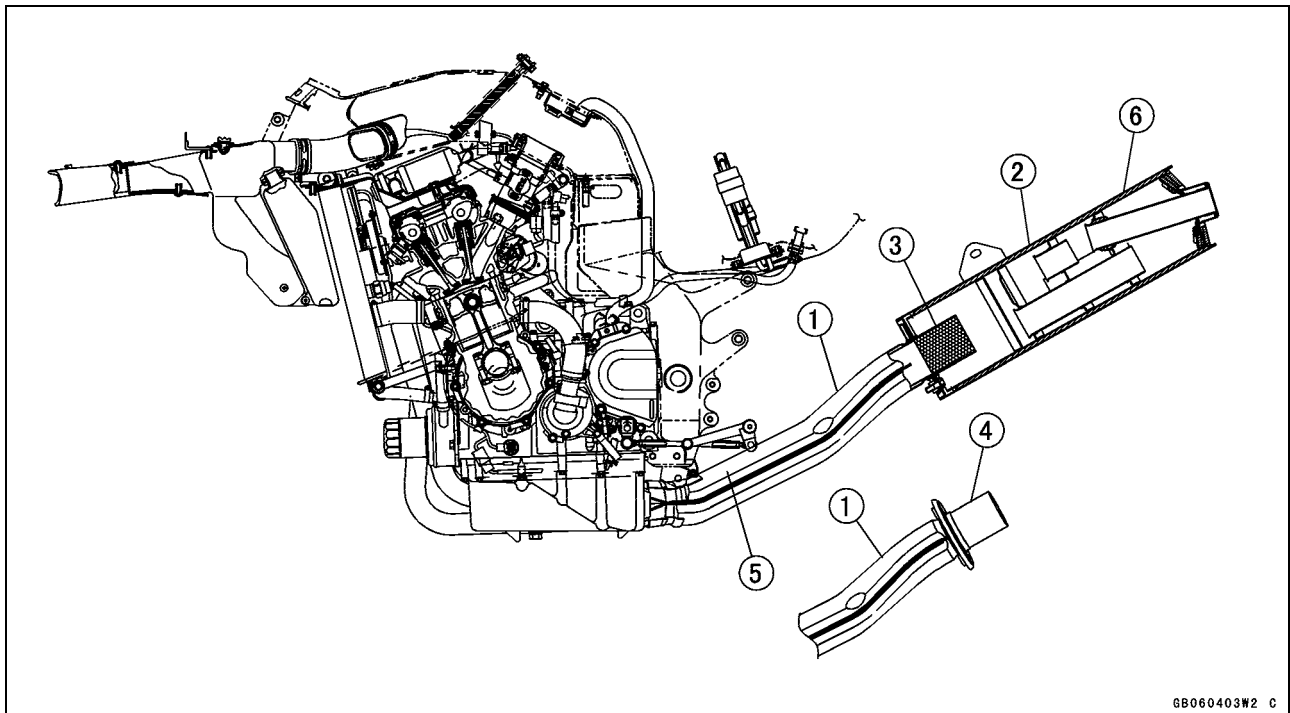

1. Manifold
2. Silencer
3. Honeycomb Type Catalyst
4. Non-Catalyst
5. Mark for Manifold
6. Mark for Silencer

1-10 GENERAL INFORMATION

Technical Information – KAWASAKI LOW EXHAUST EMISSION SYSTEM

Exhaust System (ZX1200-B1/B2)

MANIFOLD	SILENCER	ITEM NAME	ORG PRODUCT
Non-Catalyst <hr/> P/No. 39178-1335 Mark : KHI M 063	Non-Catalyst <hr/> P/No. 18090-1997 Mark : KHI K 412 TITANIUM	AUSTRALIA	ZX1200-B1 ~
Honeycomb Type Catalyst <hr/> P/No. 39178-1338 Mark : KHI M 070	Non-Catalyst <hr/> P/No. 18090-1995 Mark : KHI K 400 TITANIUM	WVTA (FULL H) UK WVTA (FULL H) ISRAEL WVTA (78.2 H) MALAYSIA	ZX1200-B1H ~ ZX1200-B1H ~ ZX1200-B1 ~ ZX1200-B1H ~ ZX1200-B1 ~
Honeycomb Type Catalyst <hr/> P/No. 39178-1336 Mark : KHI M 070	Non-Catalyst <hr/> P/No. 18090-1996 Mark : KHI K 400 EPA Noise Emission Control Information TITANIUM	U.S.A. (CALIF) U.S.A. CANADA	ZX1200-B1L ~ ZX1200-B1 ~ ZX1200-B1 ~

GEO2106B F

78.2: Horsepower 78.2 kW (106.3 ps)

Full: Full Power

H: Honeycomb Type Catalyst

UK: United Kingdom Model

Technical Information – KAWASAKI LOW EXHAUST EMISSION SYSTEM

Exhaust System (ZX1200-B3)

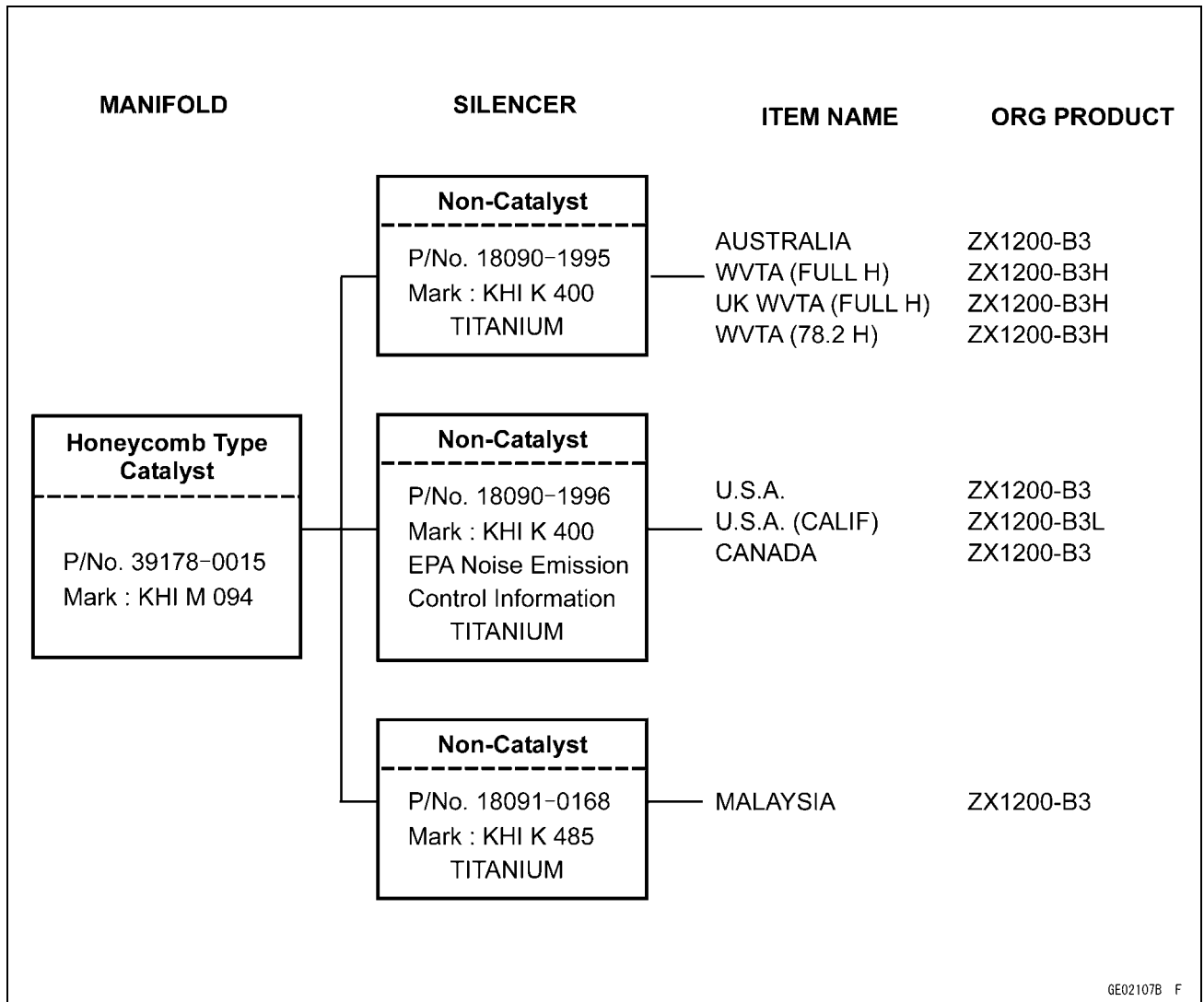

GE02107B F

78.2: Horsepower 78.2 kW (106.3 ps)
 Full: Full Power
 H: Honeycomb Type Catalyst
 UK: United Kingdom Model

1-12 GENERAL INFORMATION

Technical Information – Monocoque Frame

Why a monocoque? Like all breakthrough innovations, the choice appears quite obvious after the fact. When large-section aluminium spars are wrapped around an already wide, large-displacement in-line Four engine, the resulting package must of necessity be wide. The ZX-12R's all-aluminium box-section monocoque chassis eliminates these perimeter spars in favor of a large box section running over the top of the engine.

This frame design surpasses the levels of chassis stiffness and strength associated with conventional aluminium twin-beam frames, but with considerably less breadth. Without the twin beams or other frame elements running around the side of the engine, the fairing can be much narrower, resulting in a much slimmer overall package and significantly better aerodynamics. Further, in a radical departure, the hollow structure also doubles as an airbox for the Ram Air system, eliminating the need for a space-consuming, conventional airbox.

And ultimately, it is the synergy of combining a compact, massively powerful engine with this super stiff and slim chassis structure that explains much of the ZX-12R's superlative high-speed performance.

- All-new frame-integrated Ram Air system adds considerable horsepower in the higher speed ranges.
- Monocoque frame allows for the use of perfectly straight, highly efficient inlet ports.
- Using the frame backbone as an airbox saves space and creates a very efficient airbox.
- Battery mounts inside the frame and the battery cover is a structural element.
- Revolutionary new all-aluminum monocoque frame for high rigidity and lightweight.
- Huge box section and heat-treated cast steering head/swingarm pivot areas realize an extremely stiff structure and contribute to the ZX-12R's superb high-speed stability and nimble, super sport handling performance.
- By eliminating the dual large-section beams of conventional aluminum frames, this frame design makes possible a much narrower and more compact overall package and greatly improves aerodynamics.

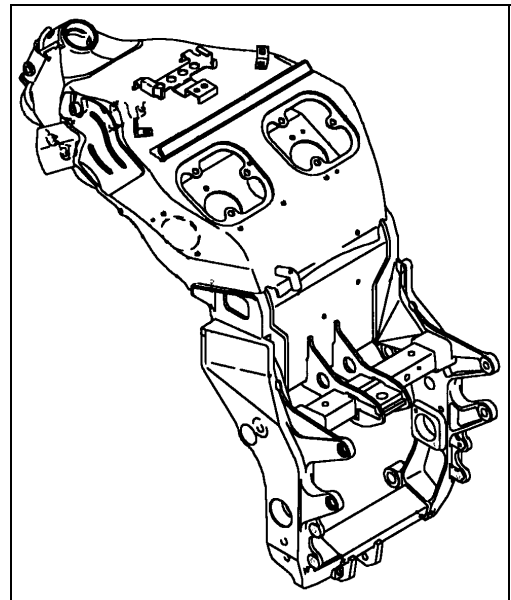

Technical Information – Spark Plug

ZX1200-B1 is equipped with the Kawasaki recommended spark plug (NGK CR9EKPA). By using the Kawasaki recommended spark plug, the idling stability, the fuel consumption improvement, and the maintenance free spark plug is planned.

This spark plug is calculated 3 or 4 times as durable as the usual one (NGK CR9EK).

Feature

1. This spark plug is more superior to the usual one with the ignition for the ignition point protruding.
2. Further, this spark plug is superior to the usual one with the endurance for the Pt alloy [A] covering around the center electrode and for the opposed area improvement of the side electrodes.

Specification

1. Standard Spark Plug CR9EKPA, two side electrodes, M10 threads
2. Hotter Spark Plug CR8EKPA, two side electrodes, M10 threads

CAUTION

Use only the recommender spark plug. Do not use other spark plug, even though it may fit, because it could cause the engine failure of the idling stability, etc.

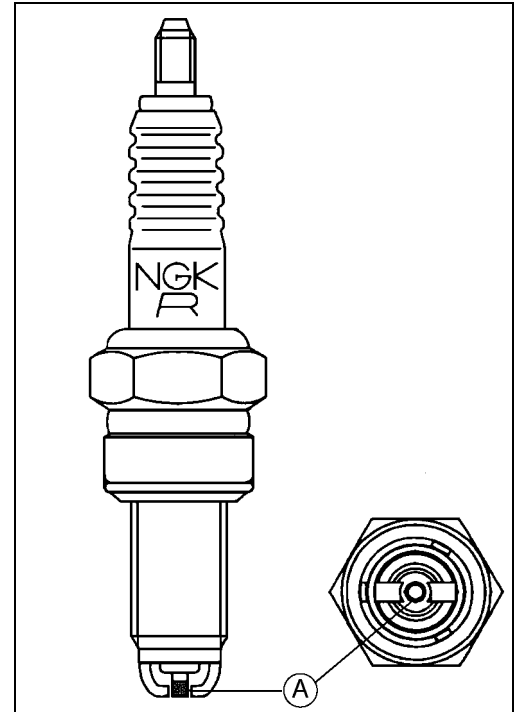

1-14 GENERAL INFORMATION

Technical Information – Immobilizer System (ZX1200-B3)

Overview

This system provides a theft proof device by means of matching a code between the inbuilt key transponder and the ECU (Electronic Control Unit). If this code does not match, the fuel pump, injectors, ignition system and sub-throttle valve actuator will not operate and the engine will not start.

Related Parts and Function

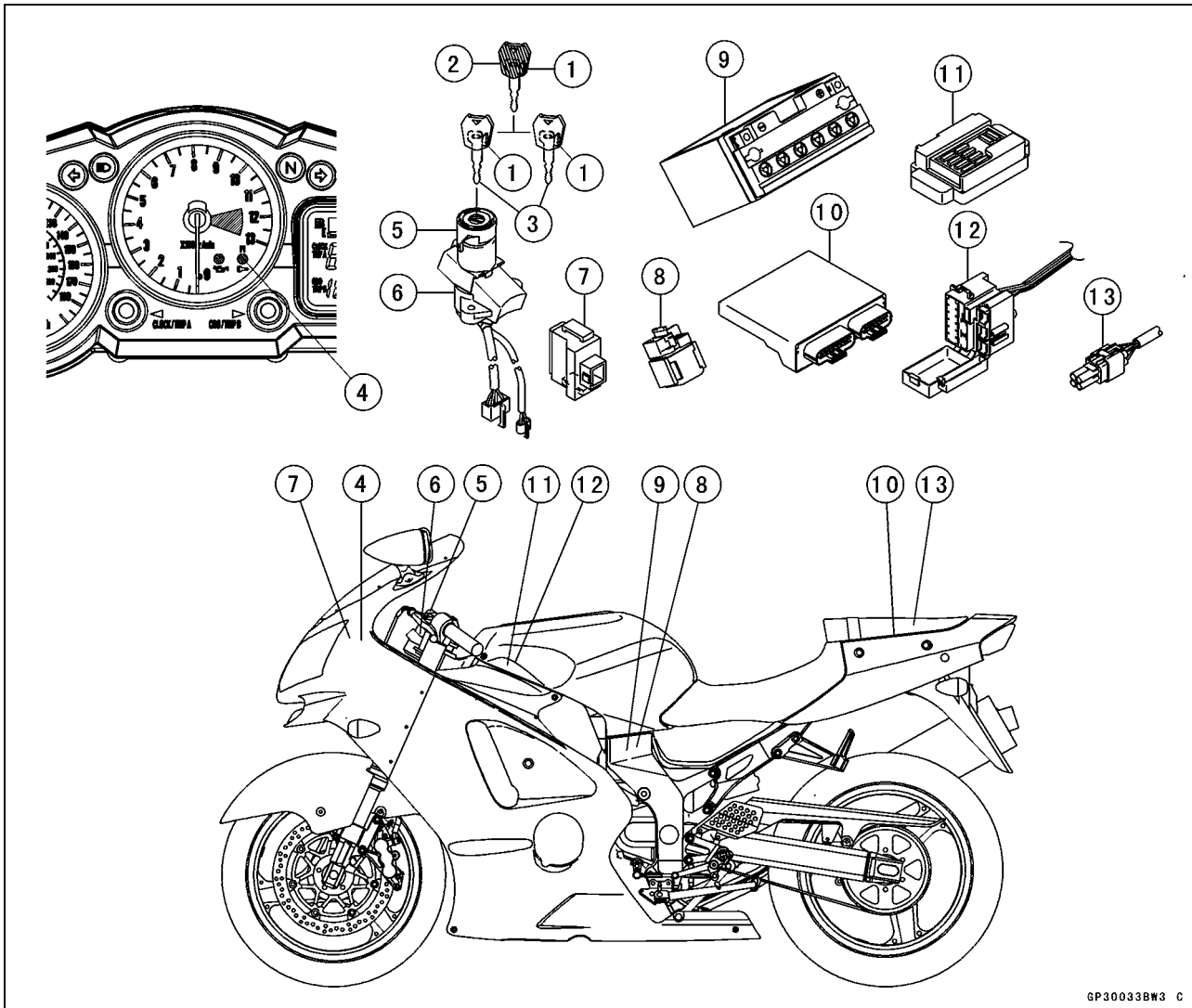

GP30033BW3 C

- | | |
|------------------------------|--|
| 1. Transponder (Inside Keys) | 8. Starter Relay |
| 2. Master Key | 9. Battery |
| 3. User Keys | 10. Electronic Control Unit (ECU) |
| 4. FI Indicator Light | 11. Junction Box |
| 5. Immobilizer Antenna | 12. Fuse Box |
| 6. Ignition Switch | 13. Immobilizer/Kawasaki Diagnostic System Connector |
| 7. Immobilizer Amplifier | |

Master Key (1 piece)

The master key (colored red) has an inbuilt transponder, containing a master key code. These codes are unique to each key. This code and an additional two user key codes must be registered in the ECU for the system to operate. The master key is necessary when registering user keys and should not be used as the main key to start the motorcycle except in emergencies (loss or damage of user keys). It should be kept in a safe place.

Technical Information – Immobilizer System (ZX1200-B3)

Transponder (in Keys)

The transponder (made by Texas Instruments, Inc.) has an integrated circuit with a unique code that also calculates data sent by the ECU. When the ignition switch is turned ON, the transponder is excited by the radio wave transmitted from the antenna and then transmits a unique code to the antenna.

User Key (2 pieces)

The user keys (colored black) should be used when riding the motorcycle. These keys have unique codes which differ from the master key. Up to a maximum of five user key codes can be stored by the ECU at any one time. These codes can not be registered to the ECU without firstly registering the master key code.

Antenna

The antenna transmits a radio wave to excite the transponder, receives the code from the transponder and then transmits the code to the ECU through the amplifier.

Ignition Switch

The ignition switch turns the main circuit ON and OFF.

Amplifier

The amplifier (which is approximately the same size as a match box), amplifies signals from the antenna and the ECU.

ECU

The ECU has the capacity to store a maximum of six key code memories (one master and five user keys). The owner can have a total of five user keys at any one time. The master key memory can not be rewritten after initial registration, whereas the user key memories can be rewritten as necessary. When the ECU communicates with the transponder, a cipher generator changes the code every time it is used to avoid cloning.

FI Indicator Light

The condition or the failure of the immobilizer system is indicated by various patterns of the FI indicator light blinking.

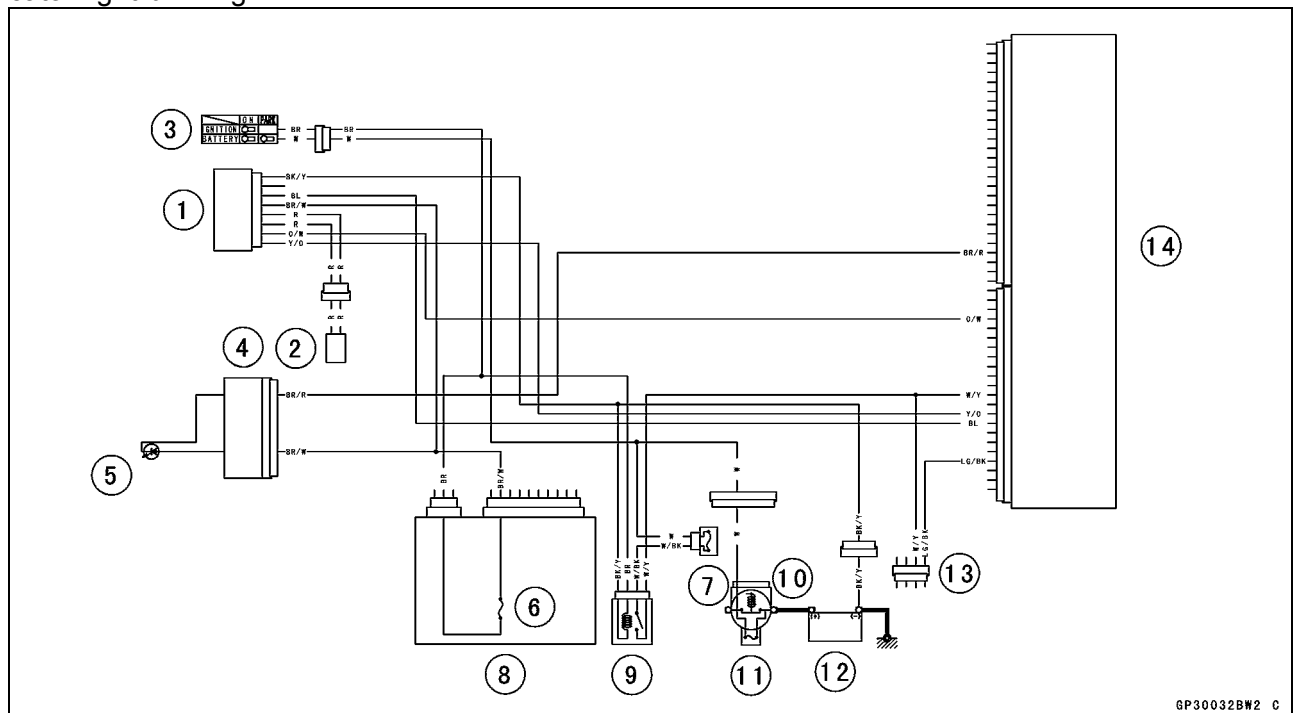

- | | |
|--------------------------|--|
| 1. Immobilizer Amplifier | 9. ECU Main Relay |
| 2. Immobilizer Antenna | 10. Starter Relay |
| 3. Ignition Switch | 11. Main Fuse 30 A |
| 4. Meter Unit | 12. Battery 12 V 12 Ah |
| 5. FI Indicator Light | 13. Immobilizer/Kawasaki Diagnostic System Connector |
| 6. Ignition Fuse 10 A | 14. Electronic Control Unit (ECU) |
| 7. ECU Fuse 15 A | |
| 8. Junction Box | |

1-16 GENERAL INFORMATION

Technical Information – Immobilizer System (ZX1200-B3)

Sequence of Operation

1. Turn ON the ignition switch, the ECU, amplifier and antenna start working, and the meter assembly FI indicator lights up.
2. The transponder excited by radio waves transmitted from the antenna receives the ciphered code from the ECU.
3. The transponder transmits the calculated result from the key's unique code to the ECU.
4. The ECU compares this with its memorized code, and if they match the engine can start. At this time, the FI indicator in the meter assembly is switched off.

Torque and Locking Agent

The following tables list the tightening torque for the major fasteners requiring use of a non-permanent locking agent or liquid gasket.

Letters used in the "Remarks" column mean:

- L:** Apply a non-permanent locking agent to the threads.
- M:** Apply molybdenum disulfide grease.
- MO:** Apply molybdenum disulfide oil solution.
- O:** Apply oil to the threads and seating surface.
- S:** Tighten the fasteners following the specified sequence.
- SS:** Apply silicone sealant.
- St:** Stake the fasteners to prevent loosening.
- R:** Replacement Parts

The table below, relating tightening torque to thread diameter, lists the basic torque for the bolts and nuts. Use this table for only the bolts and nuts which do not require a specific torque value. All of the values are for use with dry solvent-cleaned threads.

Basic Torque for General Fasteners

Threads dia.(mm)	Torque		
	N·m	kgf·m	ft·lb
5	3.4 ~ 4.9	0.35 ~ 0.50	30 ~ 43 in·lb
6	5.9 ~ 7.8	0.60 ~ 0.80	52 ~ 69 in·lb
8	14 ~ 19	1.4 ~ 1.9	10.0 ~ 13.5
10	25 ~ 34	2.6 ~ 3.5	19.0 ~ 25
12	44 ~ 61	4.5 ~ 6.2	33 ~ 45
14	73 ~ 98	7.4 ~ 10.0	54 ~ 72
16	115 ~ 155	11.5 ~ 16.0	83 ~ 115
18	165 ~ 225	17.0 ~ 23.0	125 ~ 165
20	225 ~ 325	23 ~ 33	165 ~ 240

Fastener	Torque			Remarks
	N·m	kgf·m	ft·lb	
Fuel System (DFI)				
Fuel Level Sensor Bolts	6.9	0.70	61 in·lb	L
Fuel Pump Bolts	6.9	0.70	61 in·lb	L, S
Fuel Hose Clamp Bolts	1.5	0.15	13 in·lb	
Inlet Air Pressure Sensor Bolt	12	1.2	106 in·lb	
Inlet Air Pressure Sensor Bracket Nut	12	1.2	106 in·lb	
Inlet Air Temperature Sensor	7.8	0.80	69 in·lb	
Atmospheric Pressure Sensor Bolts	12	1.2	106 in·lb	
Gear Position Switch Screws	4.0	0.40	35 in·lb	L
Crankshaft Sensor Bolts	6.0	0.60	53 in·lb	
Camshaft Position Sensor Bolt	12	1.2	106 in·lb	
Crankshaft Position Sensor Rotor Bolt	12	1.2	106 in·lb	L
Delivery Pipe Screws (ZX1200-B1/B2)	5.0	0.50	44 in·lb	
Delivery Pipe Screws (ZX1200-B3)	3.4	0.35	30 in·lb	
Nipple Assy Screws	3.5	0.35	31 in·lb	
Cooling System				
Coolant Hose Clamp Screws	2.0	0.20	18 in·lb	

1-18 GENERAL INFORMATION

Torque and Locking Agent

Fastener	Torque			Remarks
	N·m	kgf·m	ft·lb	
Coolant Fitting Nozzle (ZX1200-B1/B2)	12	1.2	106 in·lb	L
Coolant Drain Plug (Water Pump)	12	1.2	106 in·lb	
Coolant Drain Plug (Cylinder)	10	1.0	89 in·lb	
Radiator Fan Switch	18	1.8	13	
Water Temperature Sensor	25	2.5	18	SS
Water Pump Impeller Bolt	10	1.0	89 in·lb	
Water Pump Cover Bolts	12	1.2	106 in·lb	
Coolant Pipe Bolt	12	1.2	106 in·lb	
Thermostat Housing Cover Bolts	8.0	0.80	71 in·lb	L
Fitting Bolts	12	1.2	106 in·lb	
Engine Top End				
Spark Plugs	13	1.3	115 in·lb	
Air Suction Valve Cover Bolts	12	1.2	106 in·lb	
Baffle Plate Bolts	10	1.0	89 in·lb	
Cylinder Head Cover Bolts	10	1.0	89 in·lb	
Crankshaft Sensor Cover Bolts	15	1.5	11	L
Camshaft Chain Tensioner Mounting Bolts	10	1.0	89 in·lb	L
Camshaft Cap Bolts	12	1.2	106 in·lb	
Upper Camshaft Chain Guide Bolts	12	1.2	106 in·lb	
Front Camshaft Chain Guide Bolt (Upper)	25	2.5	18	
Front Camshaft Chain Guide Bolt (Lower)	12	1.2	106 in·lb	
Rear Camshaft Chain Guide Bolt	25	2.5	18	
Camshaft Position Sensor Bolt	12	1.2	106 in·lb	
Camshaft Position Sensor Rotor Bolt	12	1.2	106 in·lb	L
Cylinder Head Bolts: M11 First Tighten	23	2.3	17	MO, S (Washer)
Cylinder Head Bolts: M11 Final Tighten	59	6.0	44	MO, S (Washer)
Cylinder Head Bolts: M7	20	2.0	15	S
Cylinder Head Jacket Plugs	22	2.2	16	L
Throttle Body Holder Bolts	12	1.2	106 in·lb	
Muffler Body Connection Nuts	34	3.5	25	
Guard Mounting Bolts	12	1.2	106 in·lb	
Exhaust Pipe Holder Studs	–	–	–	(Stopped)
Clutch				
Clutch Lever Clamp Bolts	7.8	0.80	69 in·lb	S
Clutch Cover Bolts	15	1.5	11	L (2)
Clutch Cover Damper Plate Bolts	7.0	0.70	62 in·lb	L
Clutch Spring Bolts	8.8	0.90	78 in·lb	
Clutch Hub Nut	135	14	100	R
Engine Lubrication System				
Oil Level Gauge Bolts	12	1.2	106 in·lb	

Torque and Locking Agent

Fastener	Torque			Remarks
	N·m	kgf·m	ft·lb	
Oil Filler Plug	1.5 or Hand -Tight	0.15 or Hand -Tight	13 in·lb or Hand -Tight	
Engine Oil Drain Plug	20	2.0	15	
Oil Filter (Cartridge Type)	31	3.2	23	EO, R
Oil Cooler Passage Bolt	78	7.8	58	EO
Oil Cooler Mounting Bolts	25	2.5	18	L
Oil Pan Bolts	15	1.5	11	L (1)
Oil Pipe Holder Bolts	12	1.2	106 in·lb	L
Oil Pressure Relief Valve	15	1.5	11	L
Oil Pressure Switch	15	1.5	11	SS
Oil Pressure Switch Terminal Screw	1.5	0.15	13 in·lb	
Water Pump Impeller Bolt	10	1.0	89 in·lb	
Engine Removal/Installation				
Engine Mounting Bolts and Nuts: M12	59	6.0	44	
Engine Mounting Bolts and Nuts: M8	25	2.5	18	
Upper Engine Mounting Bracket Bolt: M12	59	6.0	44	
Lower Engine Mounting Bracket Bolt: M10	44	4.5	32	
Adjusting Collars	25	2.5	18	
Crankshaft/Transmission				
Breather Plate Bolts	10	1.0	89 in·lb	L
Breather Tube Bracket Bolts	12	1.2	106 in·lb	
Crankcase Bolts: M10	50	5.0	37	MO, S
Upper Crankcase Bolts: M8, L85	28	2.8	21	S
Upper Crankcase Bolts: M7	25	2.5	18	S
Lower Crankcase Bolts: M8, L99	23	2.3	17	S
Lower Crankcase Bolts: M7	20	2.0	15	S
Oil Passage Plugs (Each Side)	20	2.0	15	L
Connecting Rod Big End Nuts	in the text	←	←	←
Timing Rotor Bolt	39	4.0	29	
Starter Torque Limiter Cover Bolts	12	1.2	106 in·lb	L
Oil Pressure Switch	15	1.5	11	SS
Gear Positioning Lever Bolt	10	1.0	89 in·lb	L
Shift Shaft Return Spring Pin (Bolt)	30	3.0	22	L
Speed Sensor Bolt	12	1.2	106 in·lb	L
Shift Drum Bearing Holder Bolt	12	1.2	106 in·lb	L
Shift Drum Bearing Holder Screw	5.4	0.55	48 in·lb	L
Shift Drum Cam Bolt	12	1.2	106 in·lb	L
Balancer Shaft Clamp Lever Bolt	25	2.5	18	L
Balancer Shaft Clamp Bolt	12	1.2	106 in·lb	
Oil Pipe Holder Bolts (Crankshaft Pipe)	12	1.2	106 in·lb	L
Oil Pipe Holder Bolt (Transmission Pipe)	12	1.2	106 in·lb	
Oil Nozzle	2.5	0.25	22 in·lb	St

1-20 GENERAL INFORMATION

Torque and Locking Agent

Fastener	Torque			Remarks
	N·m	kgf·m	ft·lb	
Starter Clutch Shaft Bolt	25	2.5	18	L
Starter Clutch Shaft Plate Bolt	12	1.2	106 in·lb	L
Wheels/Tires				
Front Axle Clamp Bolts	20	2.0	15	AL
Front Axle Nut	125	13	92	
Rear Axle Nut	125	13	92	
Rear Sprocket Nuts	59	6.0	44	
Air Valve Cap	0.15	0.015	1.3 in·lb	
Final Drive				
Engine Sprocket Nut	127	13	94	MO
Engine Sprocket Cover Bolts	12	1.2	106 in·lb	
Chain Guide Bolt	12	1.2	106 in·lb	L
Rear Sprocket Nuts	59	6.0	44	
Rear Axle Nut	125	13	92	
Brakes				
Bleed Valves	7.8	0.80	69 in·lb	
Brake Hose Banjo Bolts	25	2.5	18	
Brake Lever Pivot Bolt	1.2	0.12	11 in·lb	Si
Brake Lever Pivot Bolt Locknut	6.0	0.60	52 in·lb	
Front Reservoir Cap Screws	1.5	0.15	13 in·lb	
Front Brake Light Switch Screws	1.2	0.12	11 in·lb	
Front Master Cylinder Clamp Bolts	8.8	0.90	78 in·lb	S
Front Brake Pad Spring Bolts (ZX1200-B1/B2)	3.0	0.30	27 in·lb	
Front Caliper Mounting Bolts	34	3.5	25	
Front Caliper Assembly Bolts	21	2.1	15	
Brake Disc Mounting Bolts	27	2.8	20	L
Front Brake Pad Pins (ZX1200-B3)	15	1.5	11	
Rear Caliper Mounting Bolts	25	2.5	18	
Rear Caliper Assembly Bolts	30	3.0	22	
Brake Pedal Mounting Bolt	8.8	0.90	78 in·lb	
Rear Master Cylinder Mounting Bolts	25	2.5	18	
Rear Master Cylinder Push Rod Locknut	18	1.8	13	
Suspension				
Front Fork Clamp Bolts (Upper)	20	2.0	15	
Front Fork Clamp Bolts (Lower)	20	2.0	15	AL
Front Fork Top Plugs	23	2.3	17	
Piston Rod Nut	28	2.8	21	
Front Fork Bottom Allen Bolts	40	4.0	30	L
Front Axle Clamp Bolts	20	2.0	15	AL
Rear Shock Absorber Bracket Nut	59	6.0	44	
Rear Shock Absorber Nuts (Upper and Lower)	34	3.5	25	
Swingarm Pivot Shaft Nut	125	13	92	
Swingarm Pivot Shaft Lock Nut	98	10	72	

GENERAL INFORMATION 1-21

Torque and Locking Agent

Fastener	Torque			Remarks
	N·m	kgf·m	ft·lb	
Uni-Track:				
Rocker Arm Nut	34	3.5	25	
Tie-rod Nuts	59	6.0	44	
Steering				
Steering Stem Head Nut (ZX1200-B1/B2)	54	5.5	40	
Steering Stem Head Nut (ZX1200-B3)	78	8.0	57	
Steering Stem Nut	20	2.0	15	
Handlebar Bolts	34	3.5	25	L
Handlebar Weight Bolts	–	–	–	L
Handlebar Switch Housing Screws	3.5	0.36	31 in·lb	
Frame				
Wind Shield Mounting Screws	0.40	0.040	3.5 in·lb	
Rear Frame Bolts and Nuts	44	4.5	32	
Front Footpeg Holder Bolts	25	2.5	18	
Rear Footpeg Holder Bolts	34	3.5	25	
Side Stand Bracket Bolts	49	5.0	36	
Side Stand Mounting Bolt and Nut	44	4.5	32	
Side Stand Switch Bolt	8.8	0.90	78 in·lb	L
Electrical System				
Spark Plugs	13	1.3	115 in·lb	
Alternator Rotor Bolt	110	11	81	
Stator Coil Bolts	22	2.2	16	L
Alternator Lead Holding Plate Bolts	8.5	0.87	75 in·lb	L
Engine Ground Lead Terminal Bolt	10	1.0	89 in·lb	
Alternator Cover Bolts	15	1.5	11	
Crankshaft Sensor Cover Bolts	15	1.5	11	L
Crankshaft Sensor Bolts	6.0	0.60	53 in·lb	
Camshaft Position Sensor Bolt	12	1.2	106 in·lb	
Timing Rotor Bolt	39	4.0	29	
Starter Motor Mounting Bolts	12	1.2	106 in·lb	
Handlebar Switch Housing Screws	3.5	0.36	31 in·lb	
Radiator Fan Switch	18	1.8	13	
Water Temperature Sensor	25	2.5	18	SS
Oil Pressure Switch	15	1.5	11	SS
Oil Pressure Switch Terminal Bolt	1.5	0.15	13 in·lb	
Gear Position Switch Screws	4.0	0.40	35 in·lb	L
Speed Sensor Bolt	10	1.0	89 in·lb	
Fuel Level Sensor Bolts	6.9	0.70	61 in·lb	
Front Brake Switch Light Screw	12	1.2	106 in·lb	
Tail/Brake Light Assy Mounting Nuts	6.0	0.60	53 in·lb	

1-22 GENERAL INFORMATION

Special Tools and Sealant

Oil Pressure Gauge, 5 kgf/cm²:
57001-125

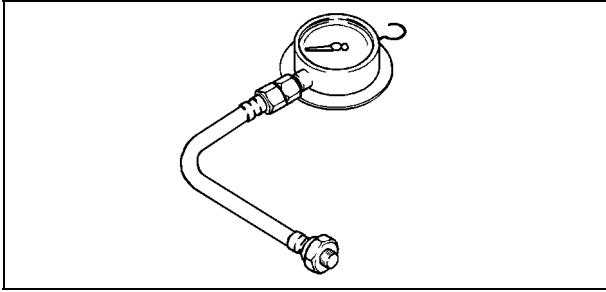

Compression Gauge, 20 kgf/cm²:
57001-221

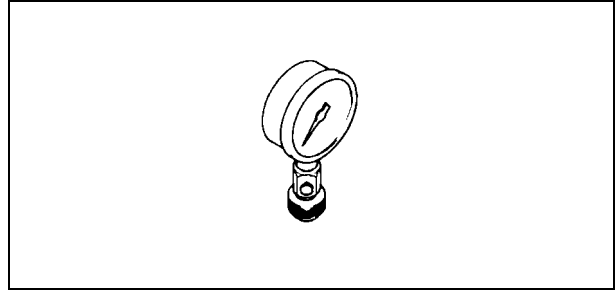

Bearing Puller:
57001-135

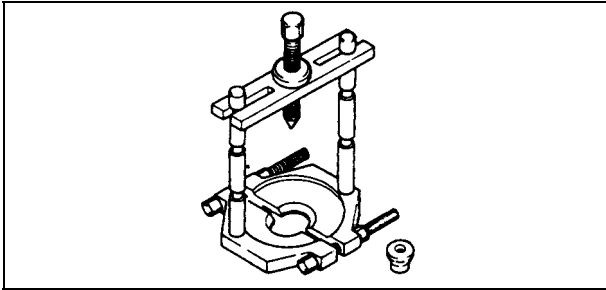

Valve Spring Compressor Assembly:
57001-241

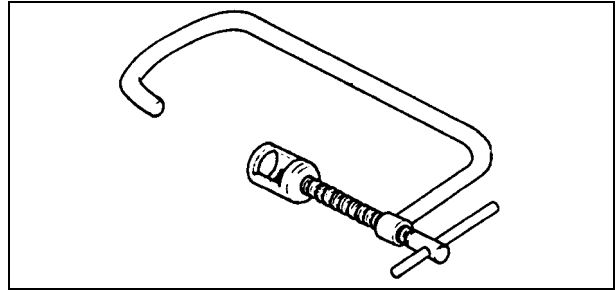

Inside Circlip Pliers:
57001-143

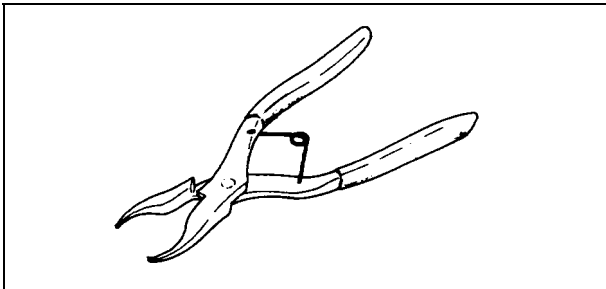

Bearing Puller Adapter:
57001-317

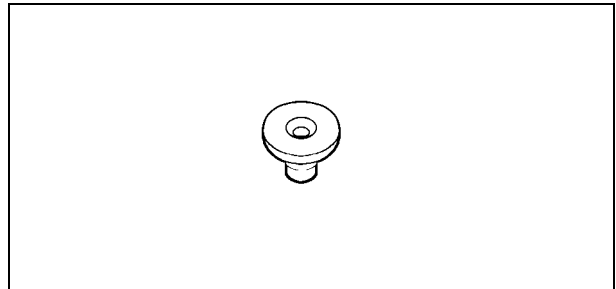

Outside Circlip Pliers:
57001-144

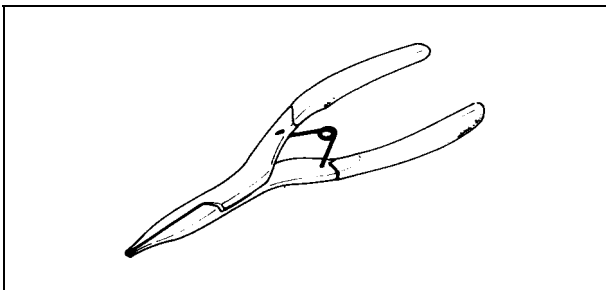

Bearing Driver:
57001-382

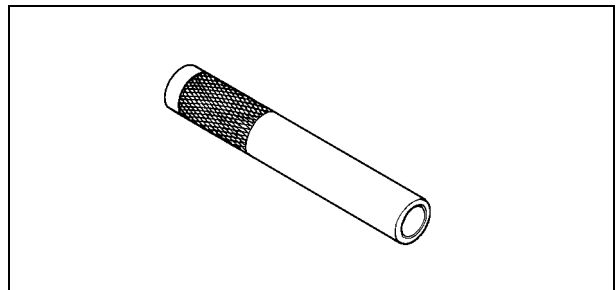

Oil Pressure Gauge, 10 kgf/cm²:
57001-164

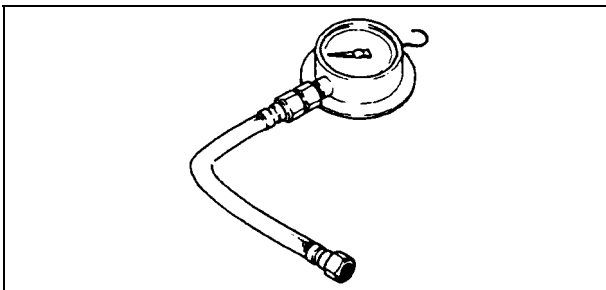

Piston Pin Puller Assembly:
57001-910

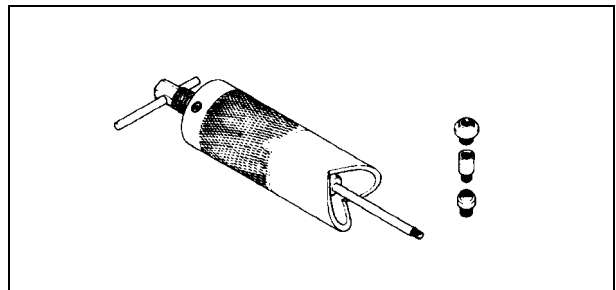

Special Tools and Sealant

Oil Pressure Gauge Adapter, PT 1/8:
57001-1033

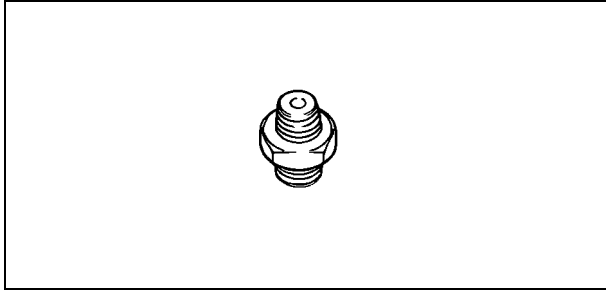

Head Pipe Outer Race Remover:
57001-1107

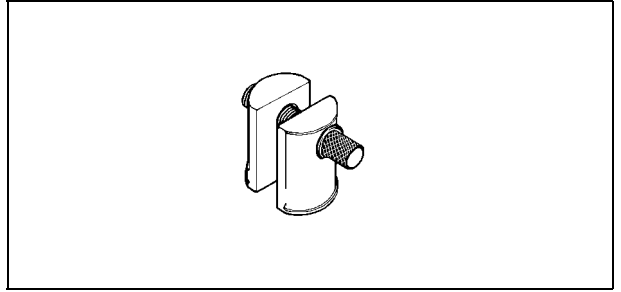

Oil Seal & Bearing Remover:
57001-1058

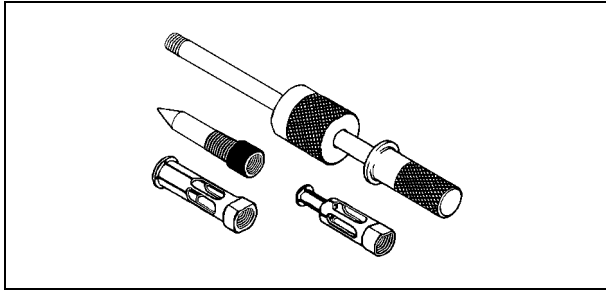

Valve Seat Cutter, 45° - $\phi 35$:
57001-1116

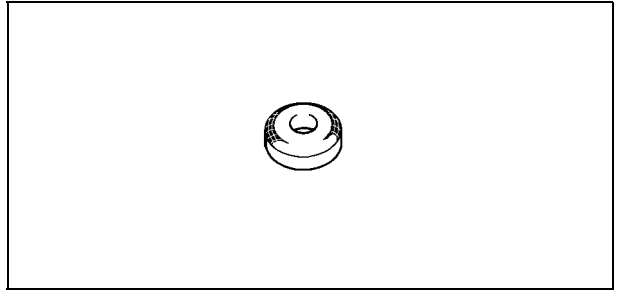

Head Pipe Outer Race Press Shaft:
57001-1075

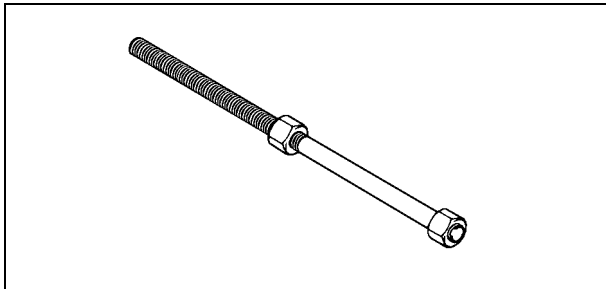

Valve Seat Cutter, 30° - $\phi 30$:
57001-1120

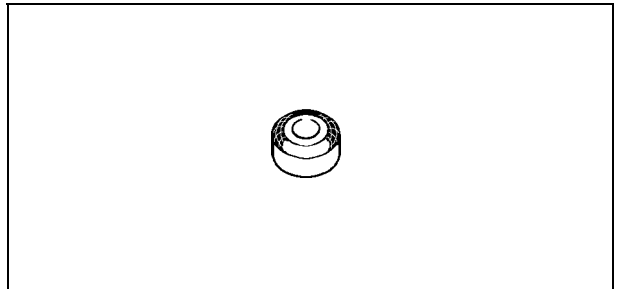

Piston Ring Compressor Grip:
57001-1095

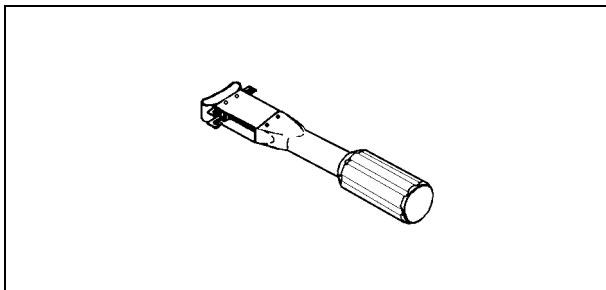

Valve Seat Cutter, 32° - $\phi 35$:
57001-1121

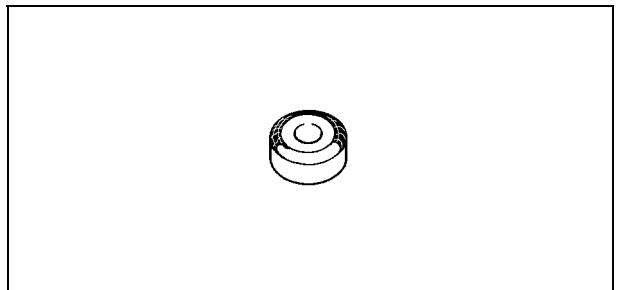

Steering Stem Nut Wrench:
57001-1100

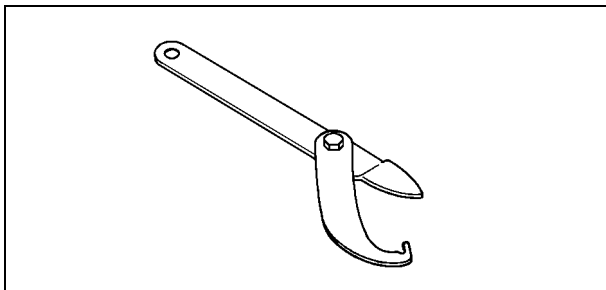

Valve Seat Cutter, 60° - $\phi 30$:
57001-1123

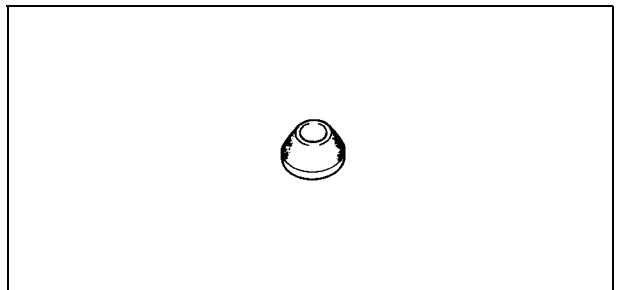

1-24 GENERAL INFORMATION

Special Tools and Sealant

Valve Seat Cutter Holder Bar:
57001-1128

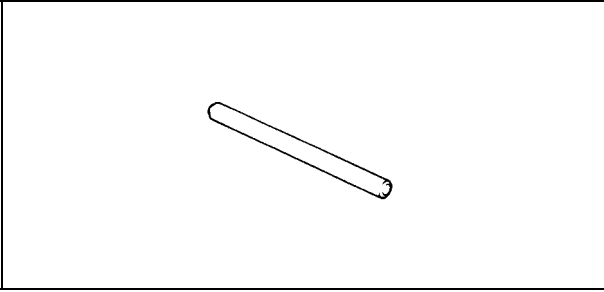

Valve Guide Reamer, $\phi 5$:
57001-1204

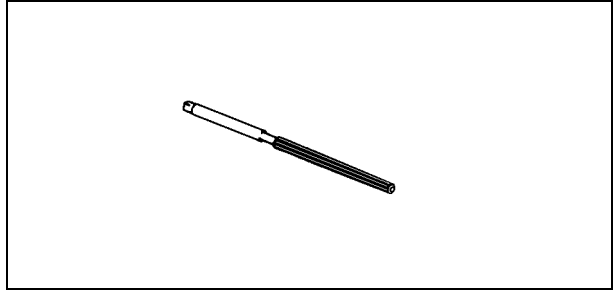

Bearing Driver Set:
57001-1129

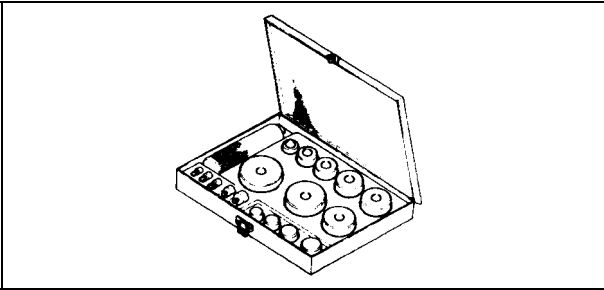

Valve Seat Cutter Holder, $\phi 5$:
57001-1208

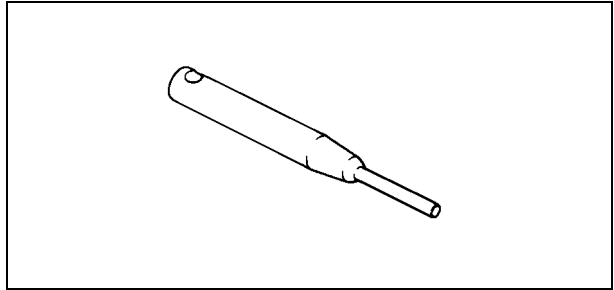

Valve Seat Cutter, $45^\circ - \phi 30$:
57001-1187

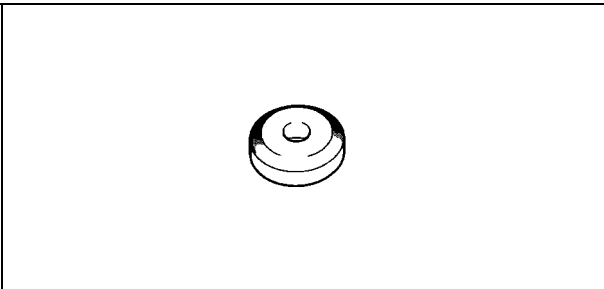

Rotor Puller, M16/M18/M20/M22 $\times 1.5$:
57001-1216

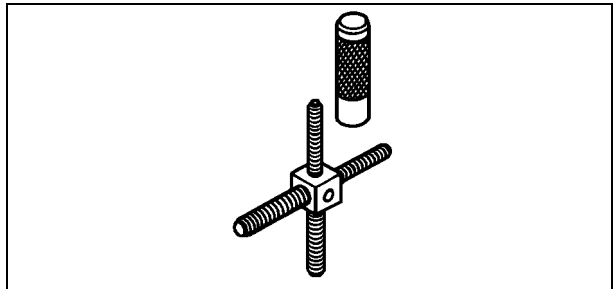

Valve Spring Compressor Adapter, $\phi 22$:
57001-1202

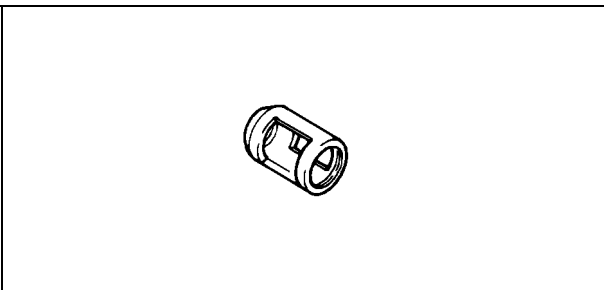

Jack:
57001-1238

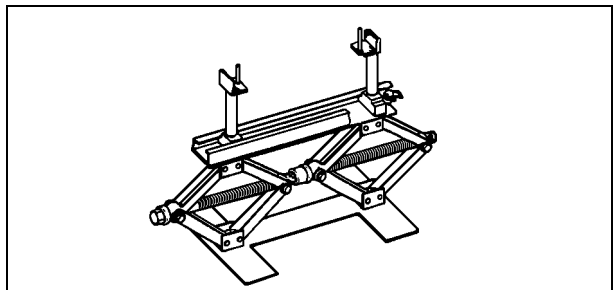

Valve Guide Arbor, $\phi 5$:
57001-1203

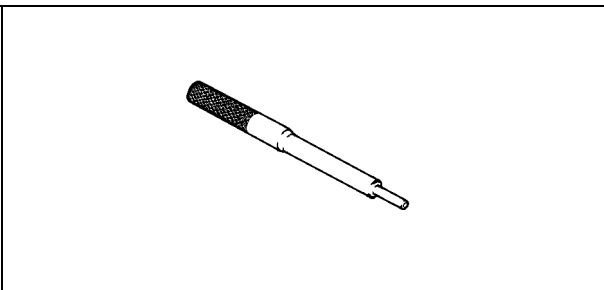

Clutch Holder:
57001-1243

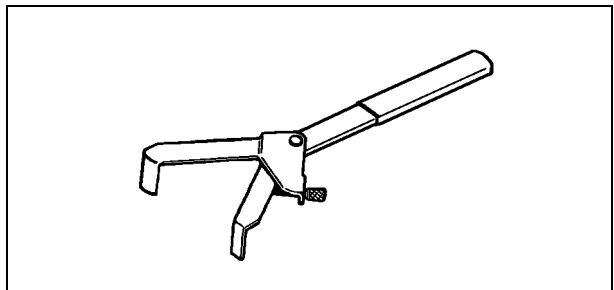

Special Tools and Sealant

Valve Seat Cutter, 55° - $\phi 35$:
57001-1247

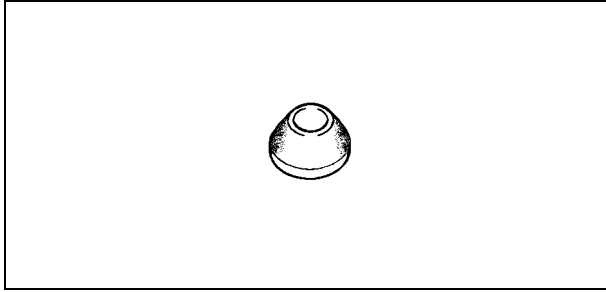

Pilot Screw Adjuster, C:
57001-1292

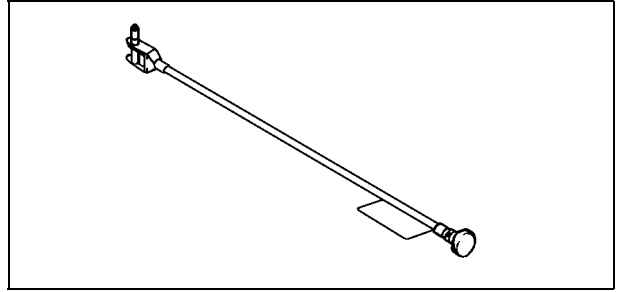

Oil Filter Wrench:
57001-1249

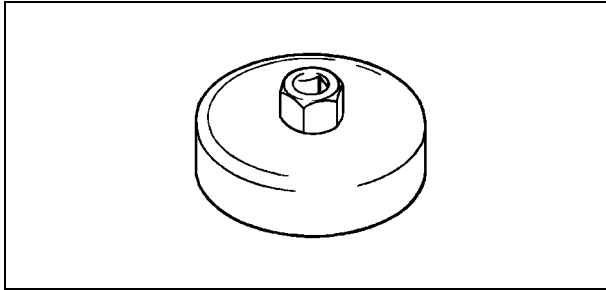

Flywheel Holder:
57001-1313

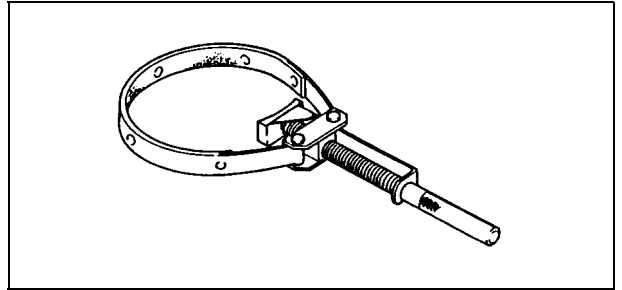

Carburetor Drain Plug Wrench, Hex 3:
57001-1269

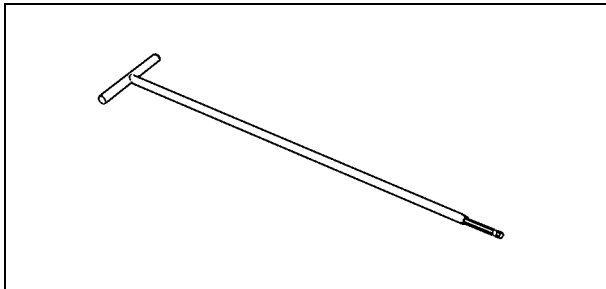

Piston Ring Compressor Belt, $\phi 80 \sim \phi 91$:
57001-1320

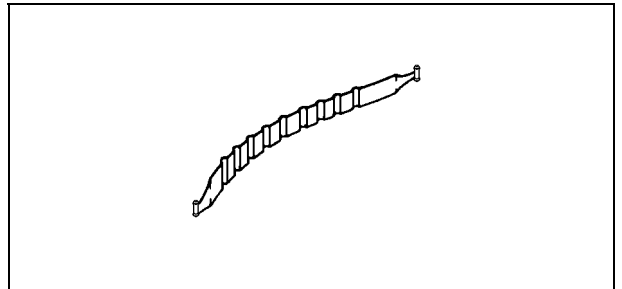

Fork Piston Rod Puller, M12 \times 1.25:
57001-1289

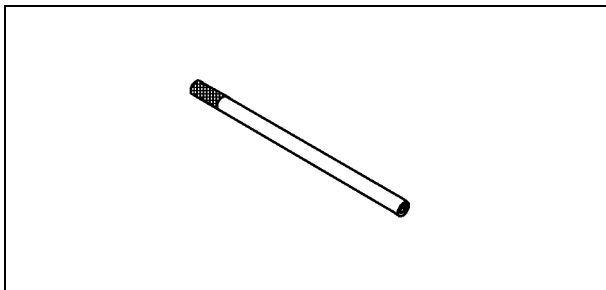

Fork Oil Seal Driver, $\phi 43$:
57001-1340

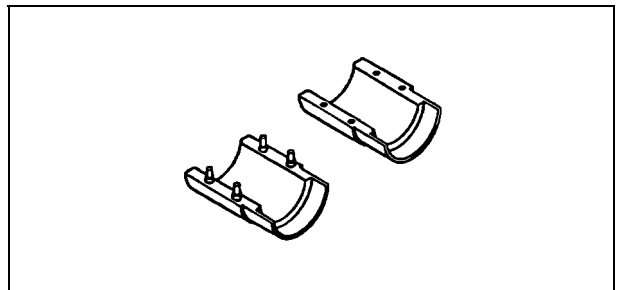

Fork Oil Level Gauge:
57001-1290

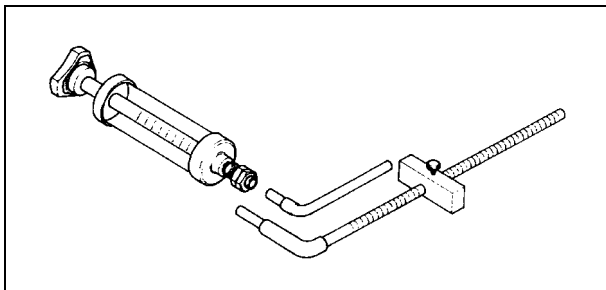

Flywheel & Pulley Holder:
57001-1343

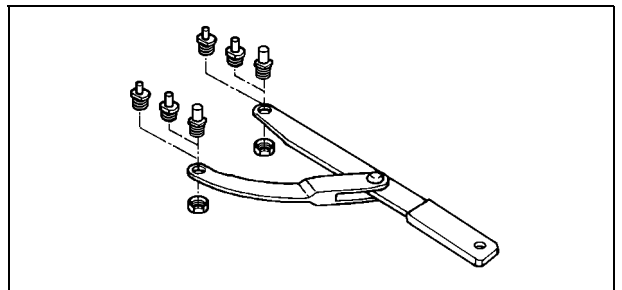

1-26 GENERAL INFORMATION

Special Tools and Sealant

Steering Stem Bearing Driver:
57001-1344

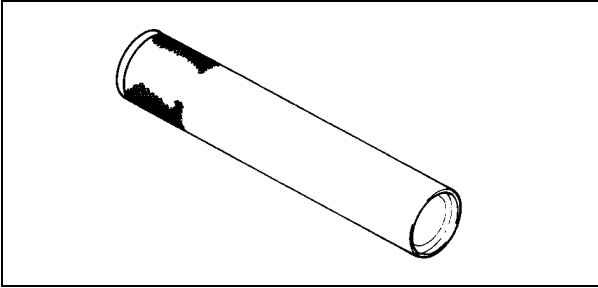

Steering Stem Bearing Driver Adapter:
57001-1345

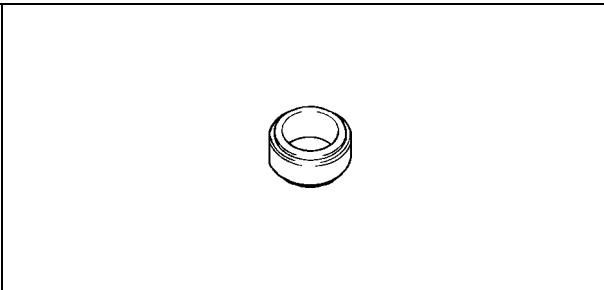

Bearing Remover Head, $\phi 25 \times \phi 28$:
57001-1346

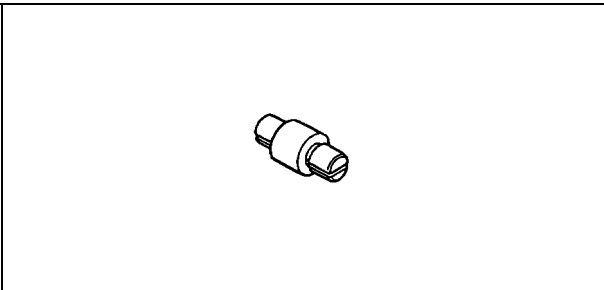

Socket Wrench:
57001-1370

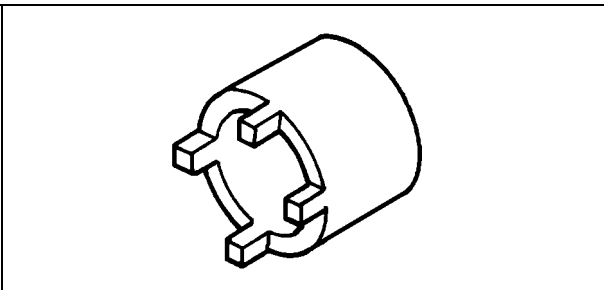

Bearing Remover Shaft, $\phi 13$:
57001-1377

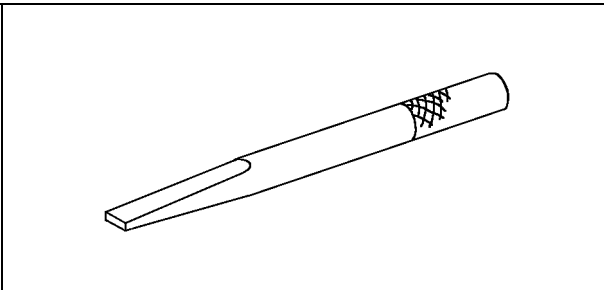

Hand Tester:
57001-1394

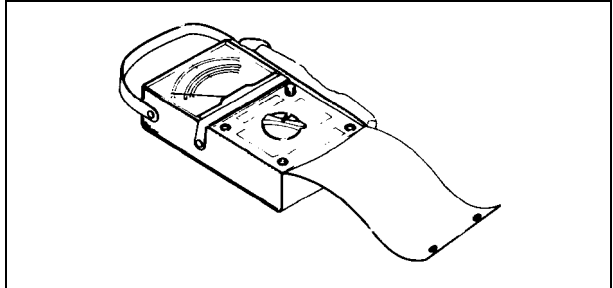

Flywheel Puller Assembly, M38 \times 1.5/M35 \times 1.5:
57001-1405

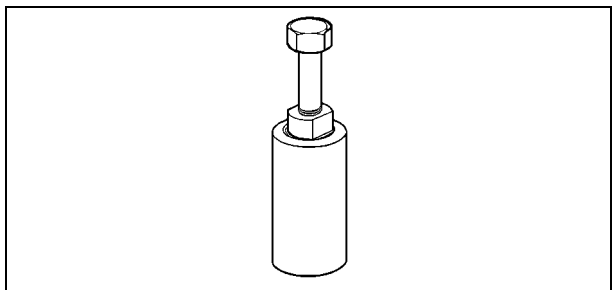

Throttle Sensor Setting Adapter #2:
57001-1408

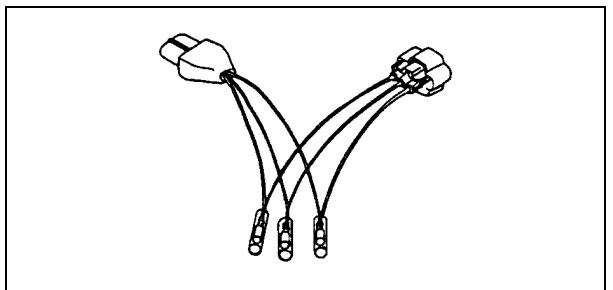

Fuel Pressure Gauge Adapter:
57001-1417

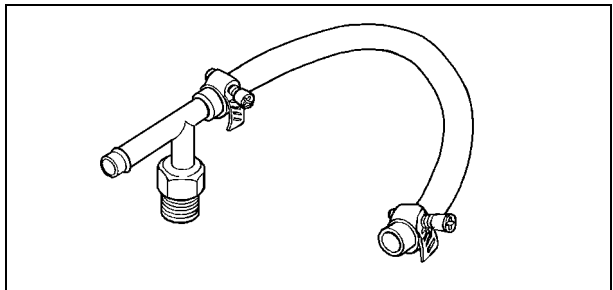

Fork Cylinder Holder:
57001-1443

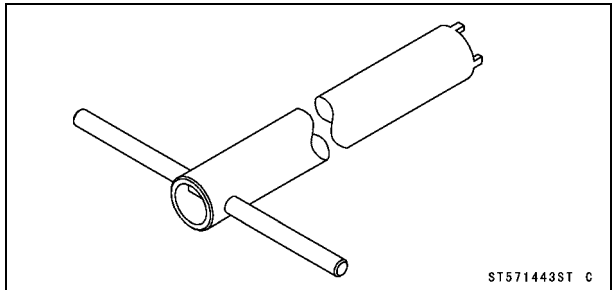

Special Tools and Sealant

Head Pipe Outer Race Driver:
57001-1446

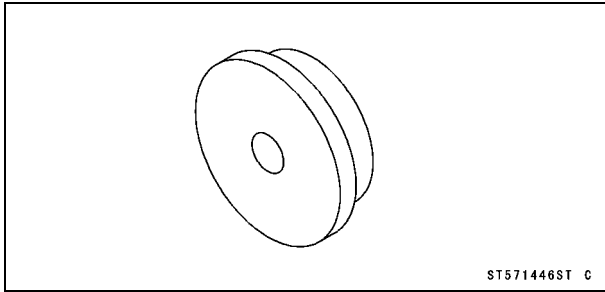

Clutch Gear Setting Screw:
57001-1455

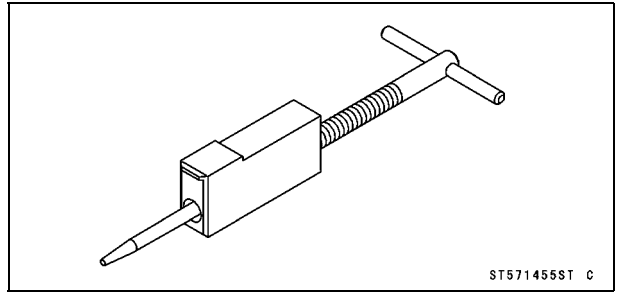

Head Pipe Outer Race Driver:
57001-1447

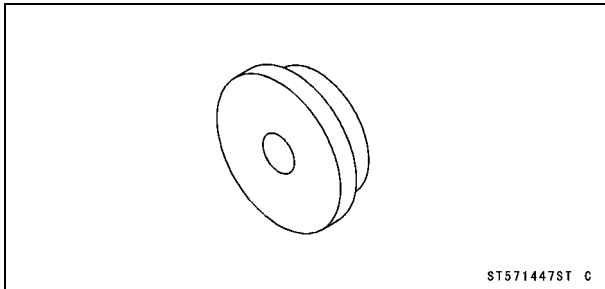

Needle Adapter Set:
57001-1457

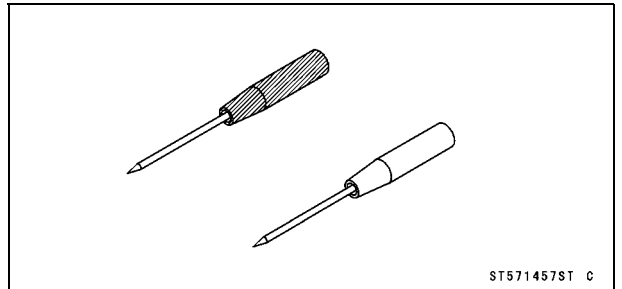

Lead Wire - Voltage Regulator Adapter:
57001-1448

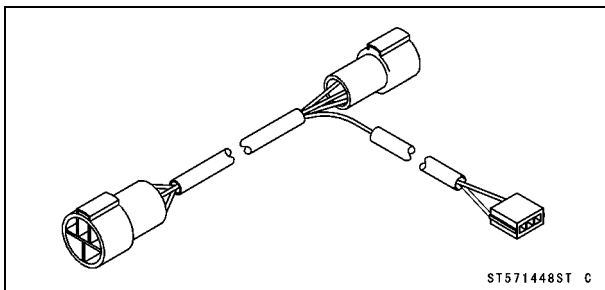

Compression Gauge Adapter, M10 × 1.0:
57001-1458

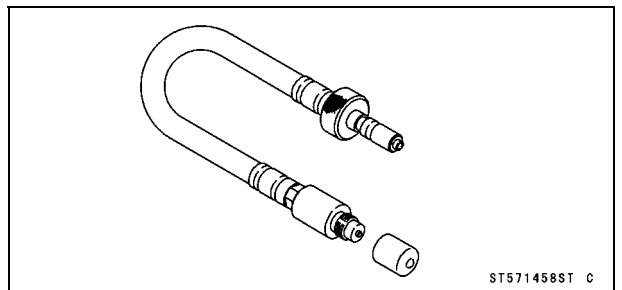

Lead Wire - Peak Voltage Adapter:
57001-1449

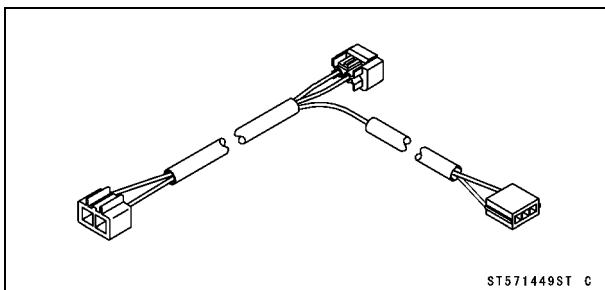

Piston Base, $\phi 10$:
57001-1459

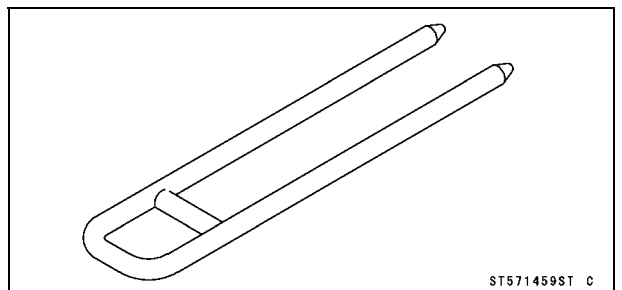

Fork Spring Compressor Set:
57001-1452

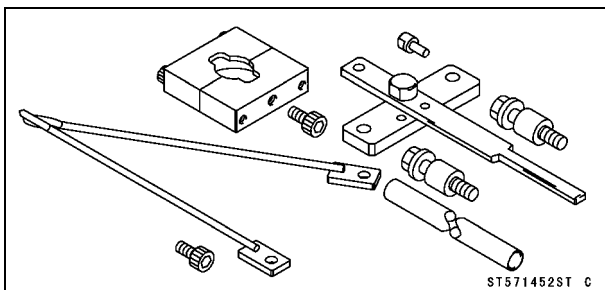

Hook Wrench:
57001-1522

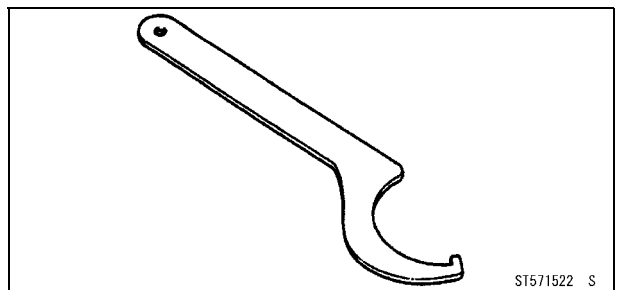

1-28 GENERAL INFORMATION

Special Tools and Sealant

Throttle Sensor Setting Adapter:
57001-1538

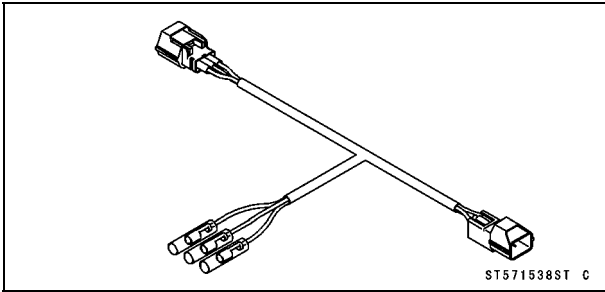

Rotor Holder:
57001-1592

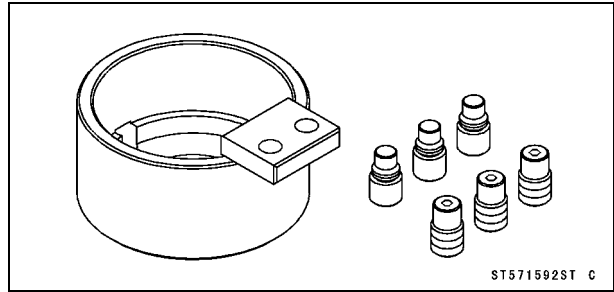

Key Registration Unit:
57001-1582

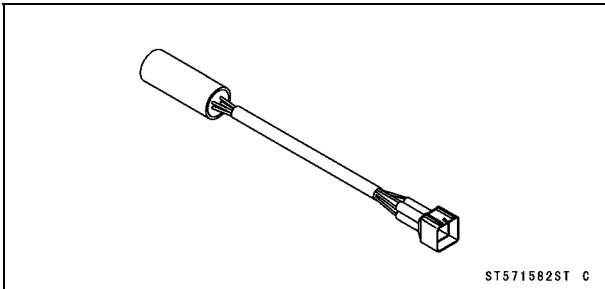

Kawasaki Bond (Silicone Sealant):
56019-120

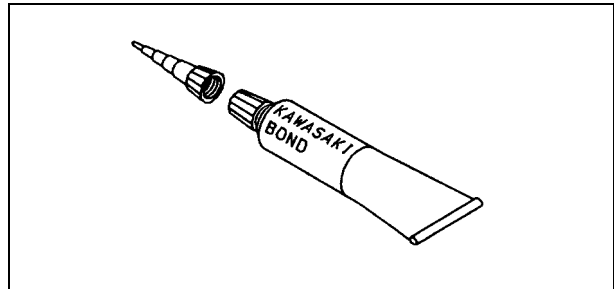

Fork Spring Compressor:
57001-1587

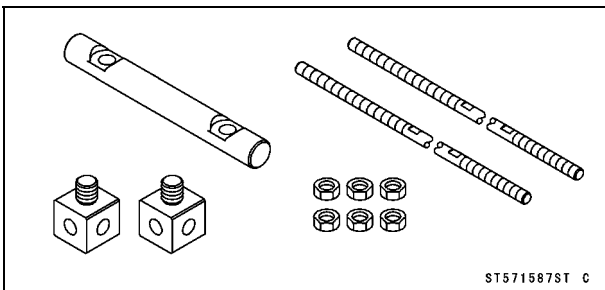

Kawasaki Bond (Liquid Gasket - Black):
92104-1062

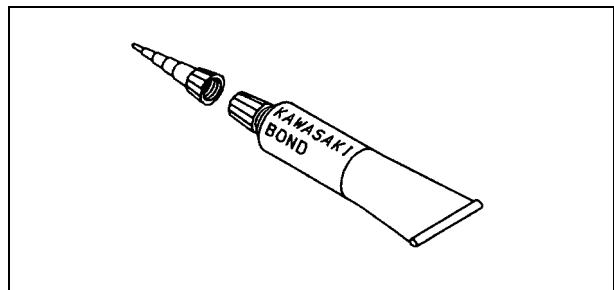

Pulley Holder, Grip:
57001-1591

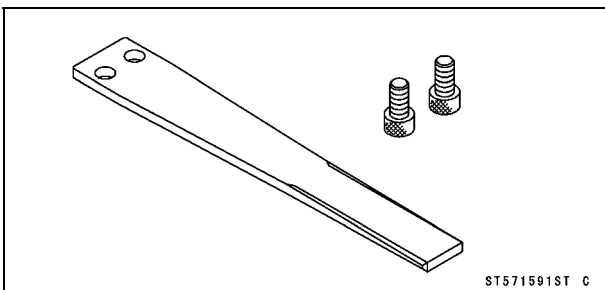

Cable, Wire, and Hose Routing (ZX1200-B1/B2)

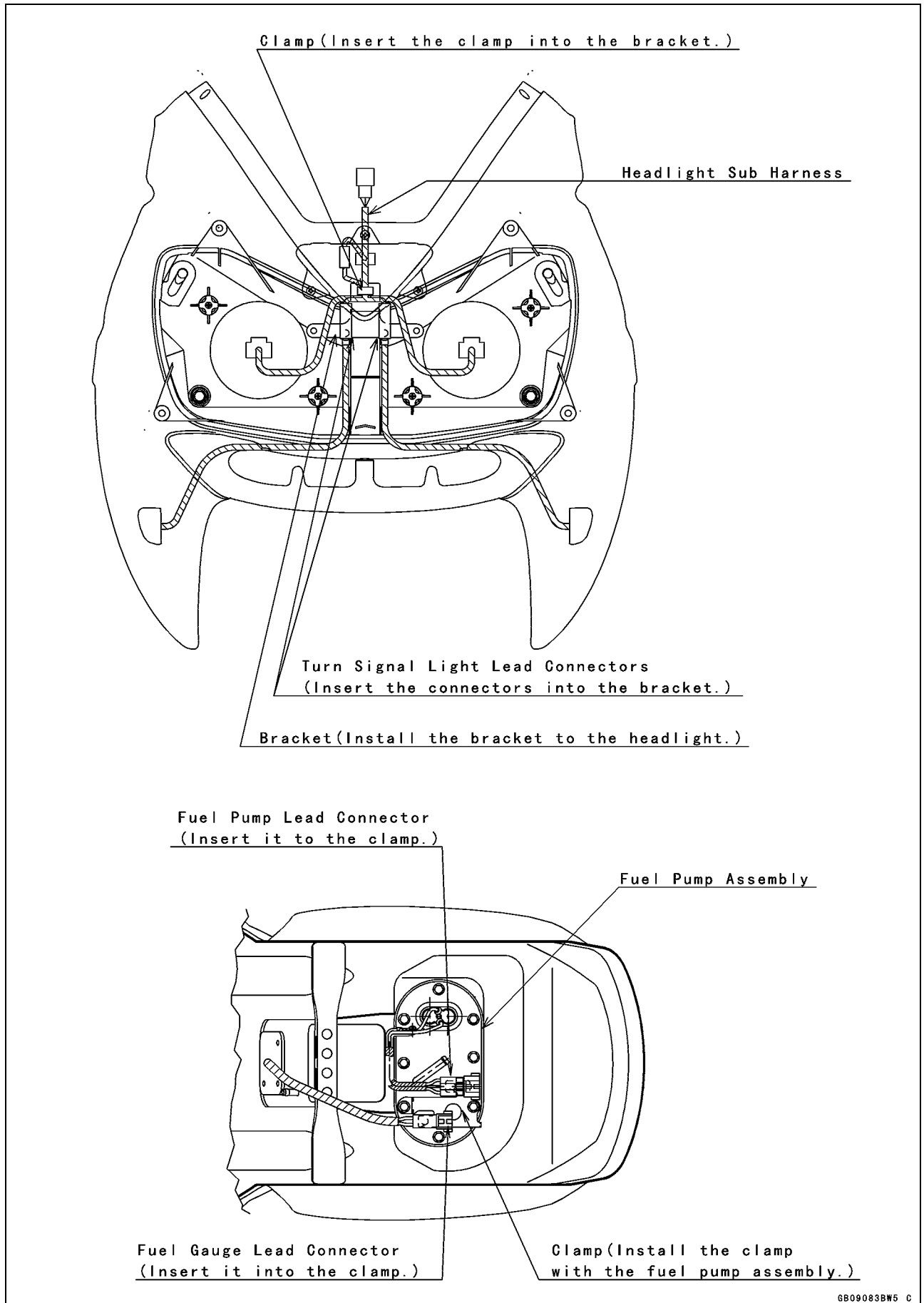

1-30 GENERAL INFORMATION

Cable, Wire, and Hose Routing (ZX1200-B1/B2)

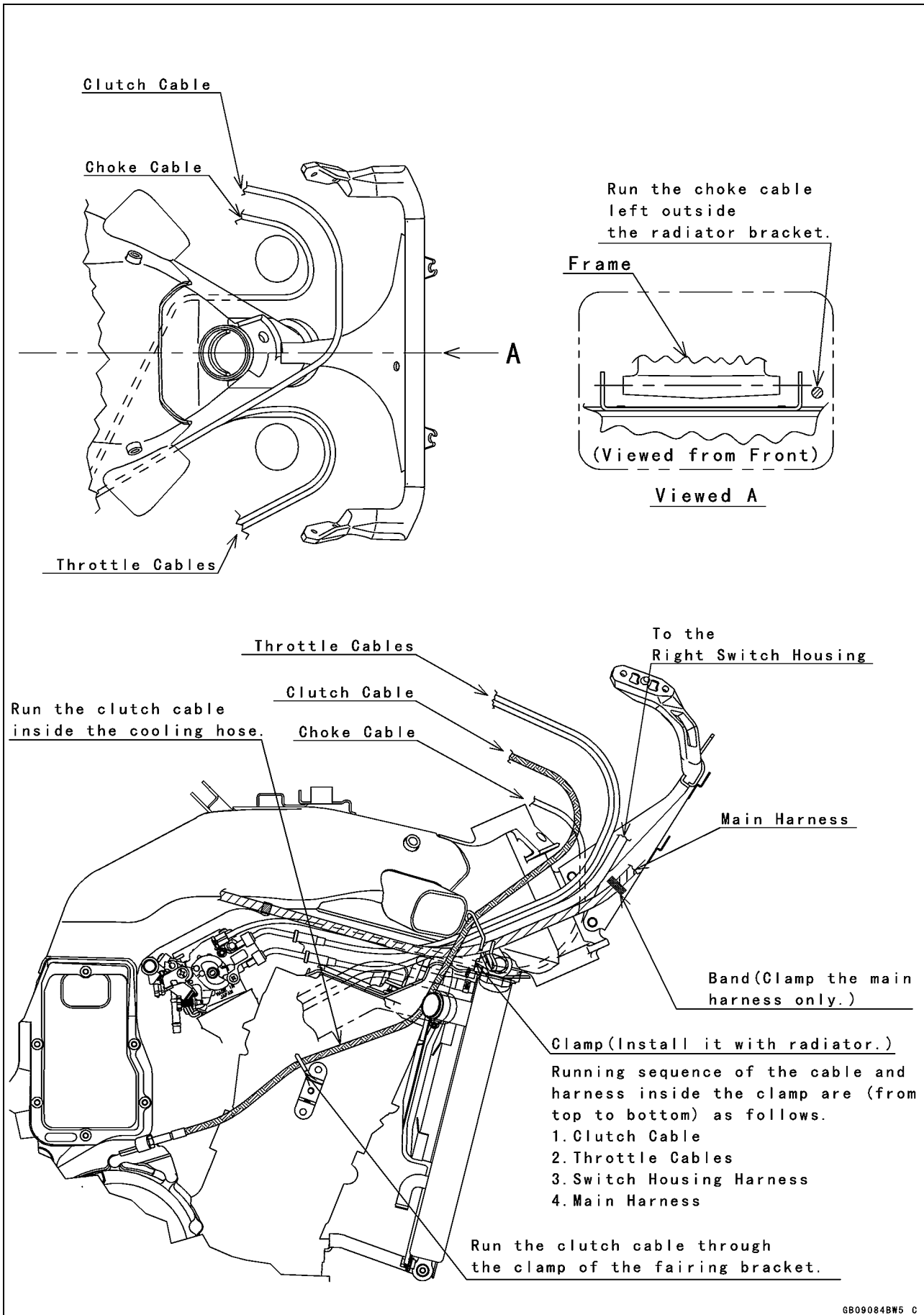

Cable, Wire, and Hose Routing (ZX1200-B1/B2)

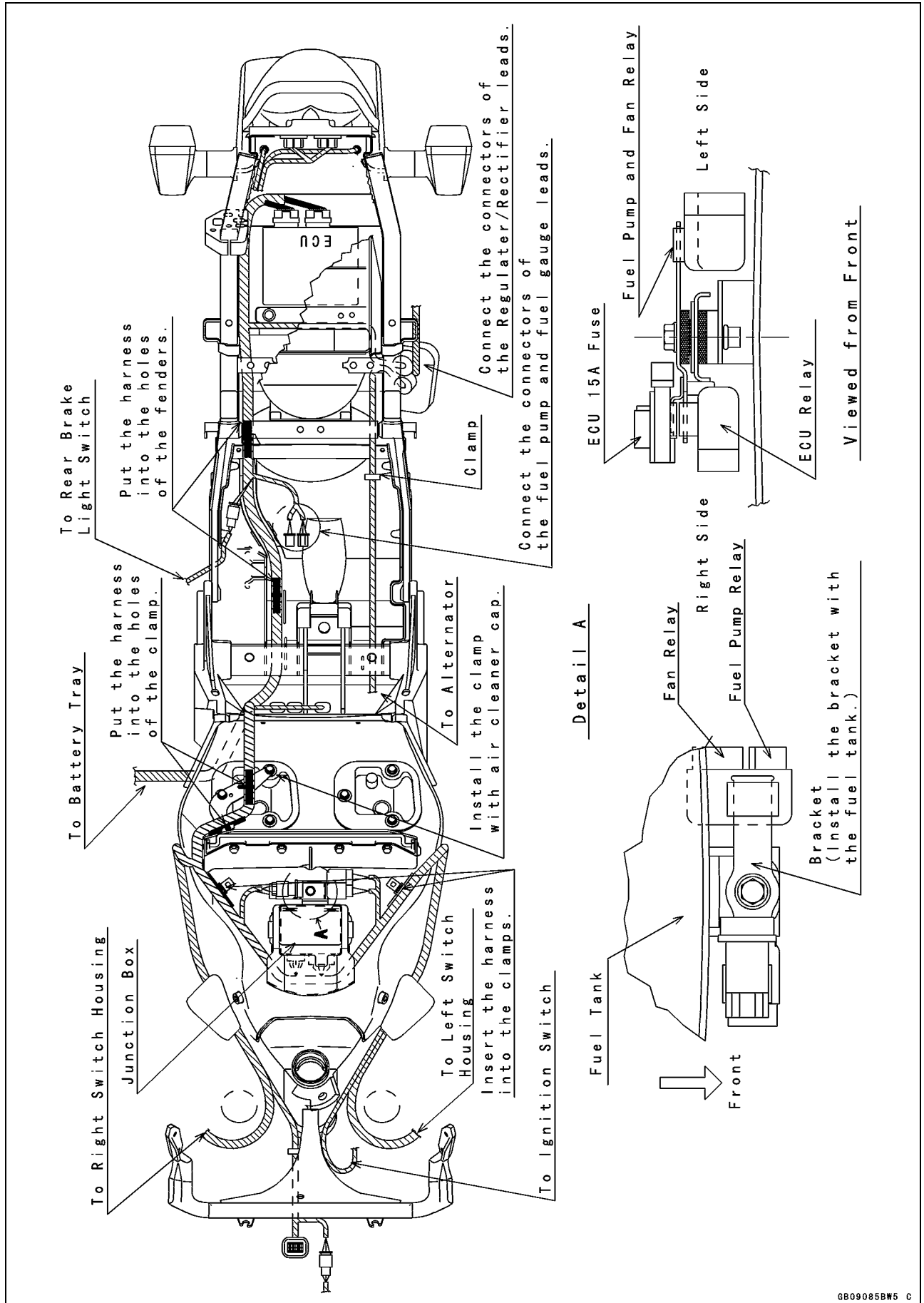

1-32 GENERAL INFORMATION

Cable, Wire, and Hose Routing (ZX1200-B1/B2)

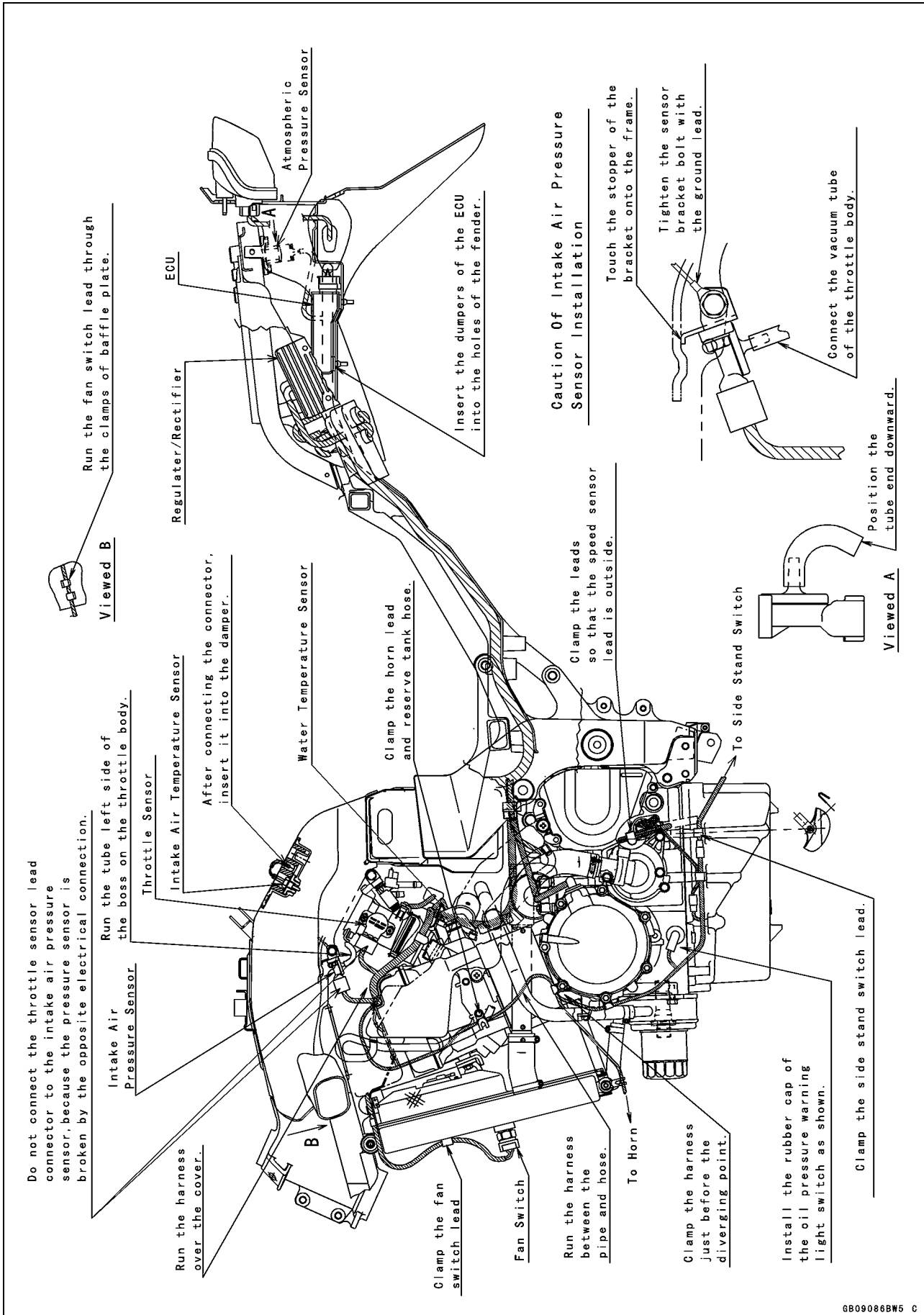

Cable, Wire, and Hose Routing (ZX1200-B1/B2)

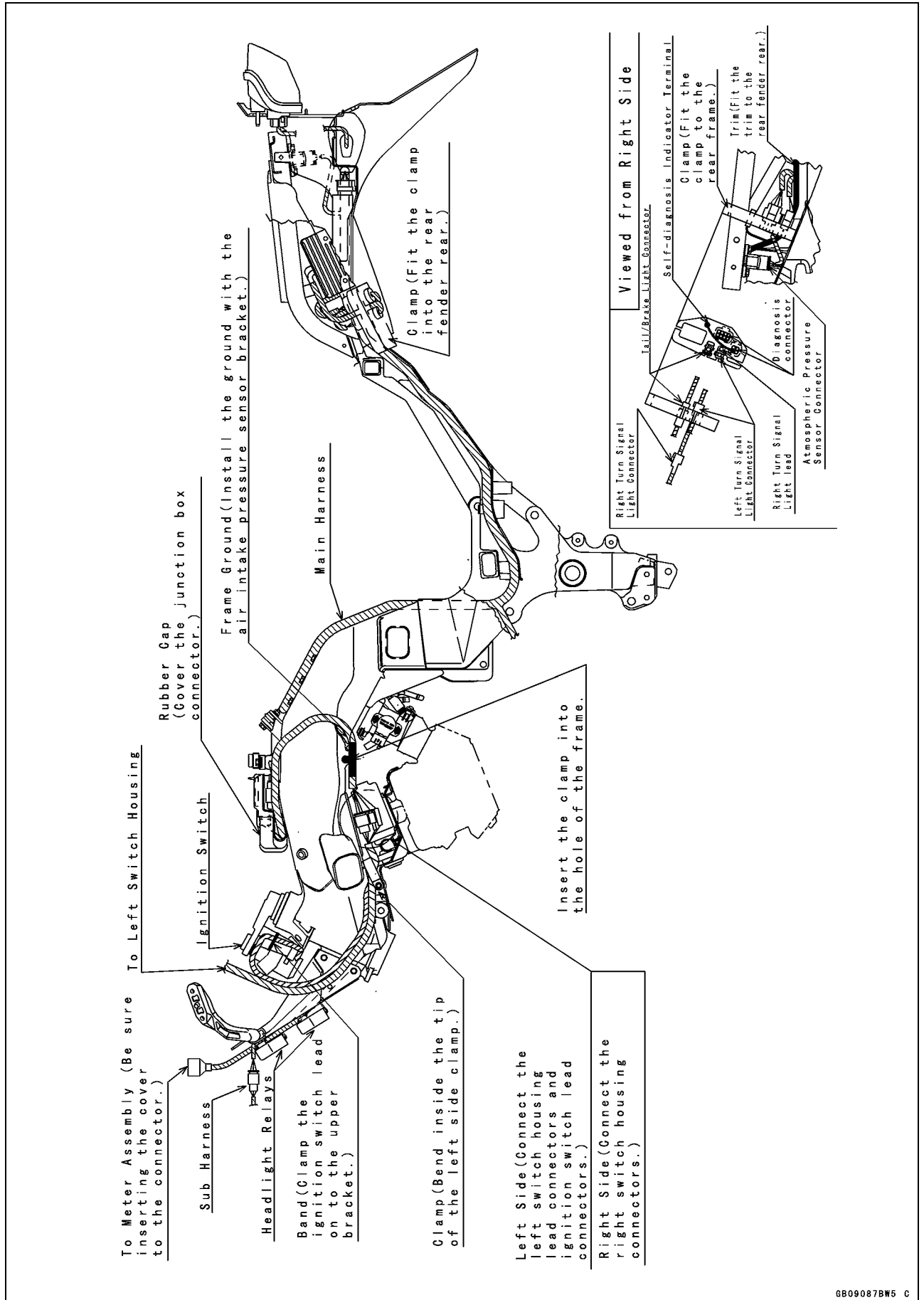

1-34 GENERAL INFORMATION

Cable, Wire, and Hose Routing (ZX1200-B1/B2)

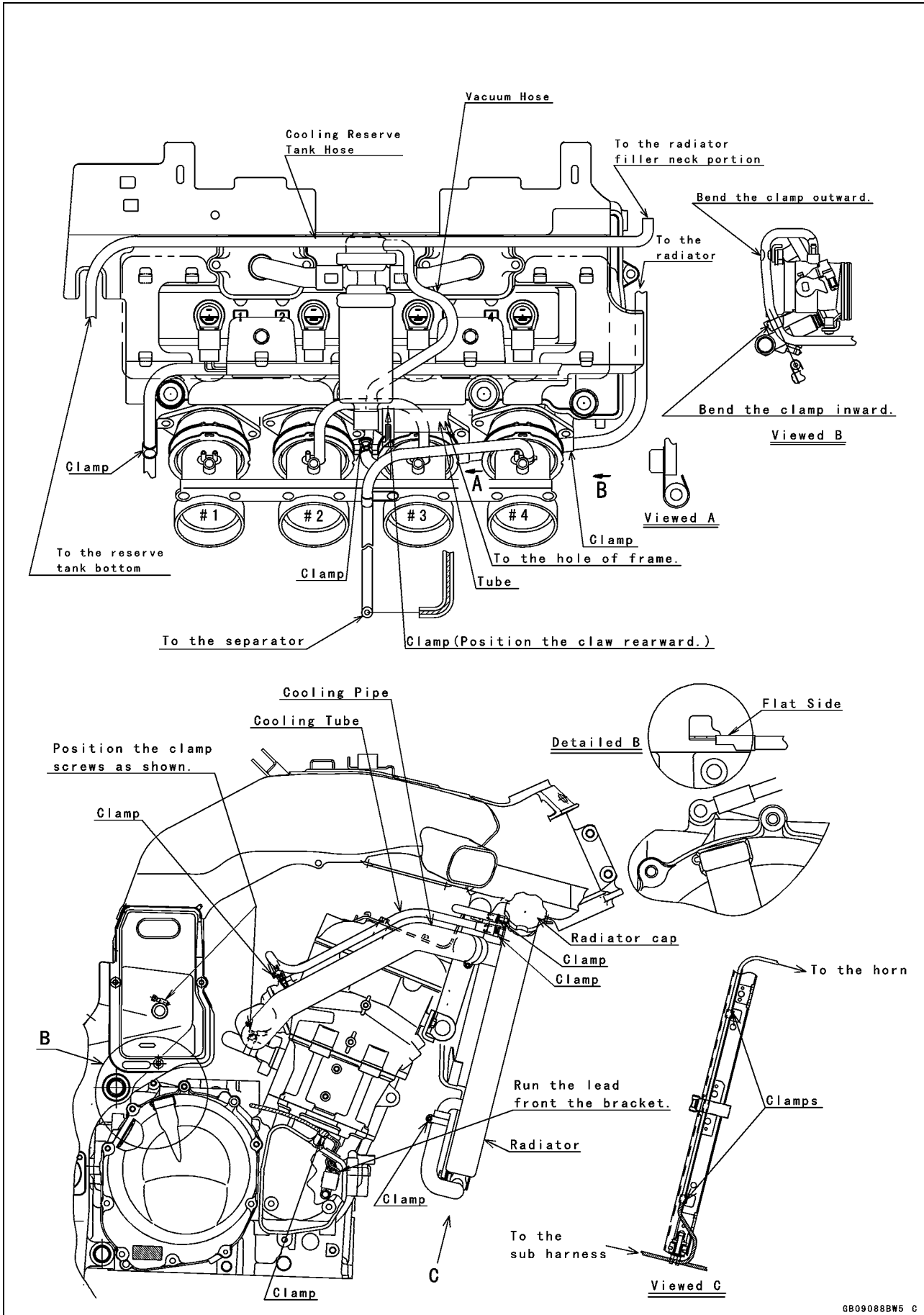

Cable, Wire, and Hose Routing (ZX1200-B1/B2)

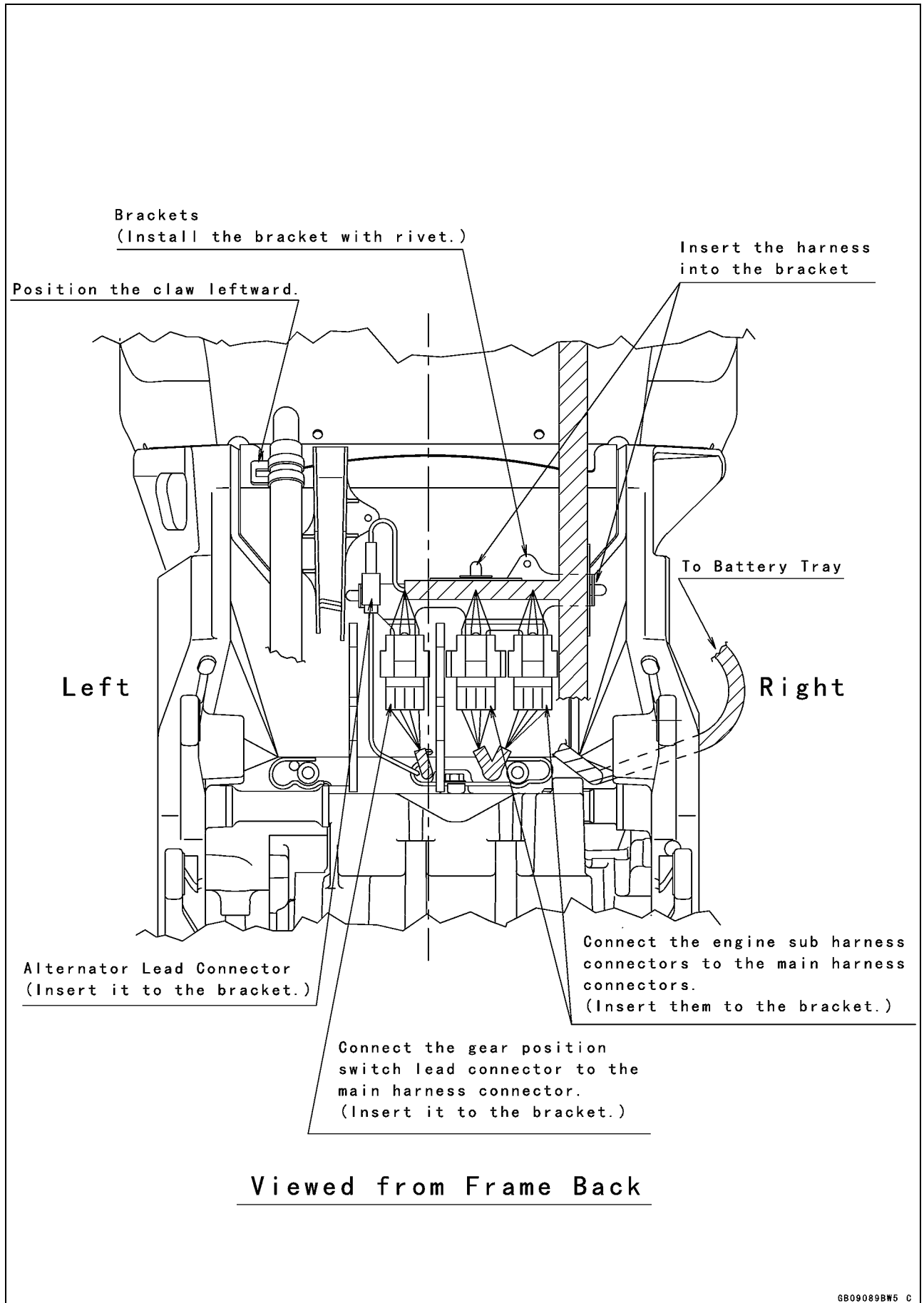

1-36 GENERAL INFORMATION

Cable, Wire, and Hose Routing (ZX1200-B1/B2)

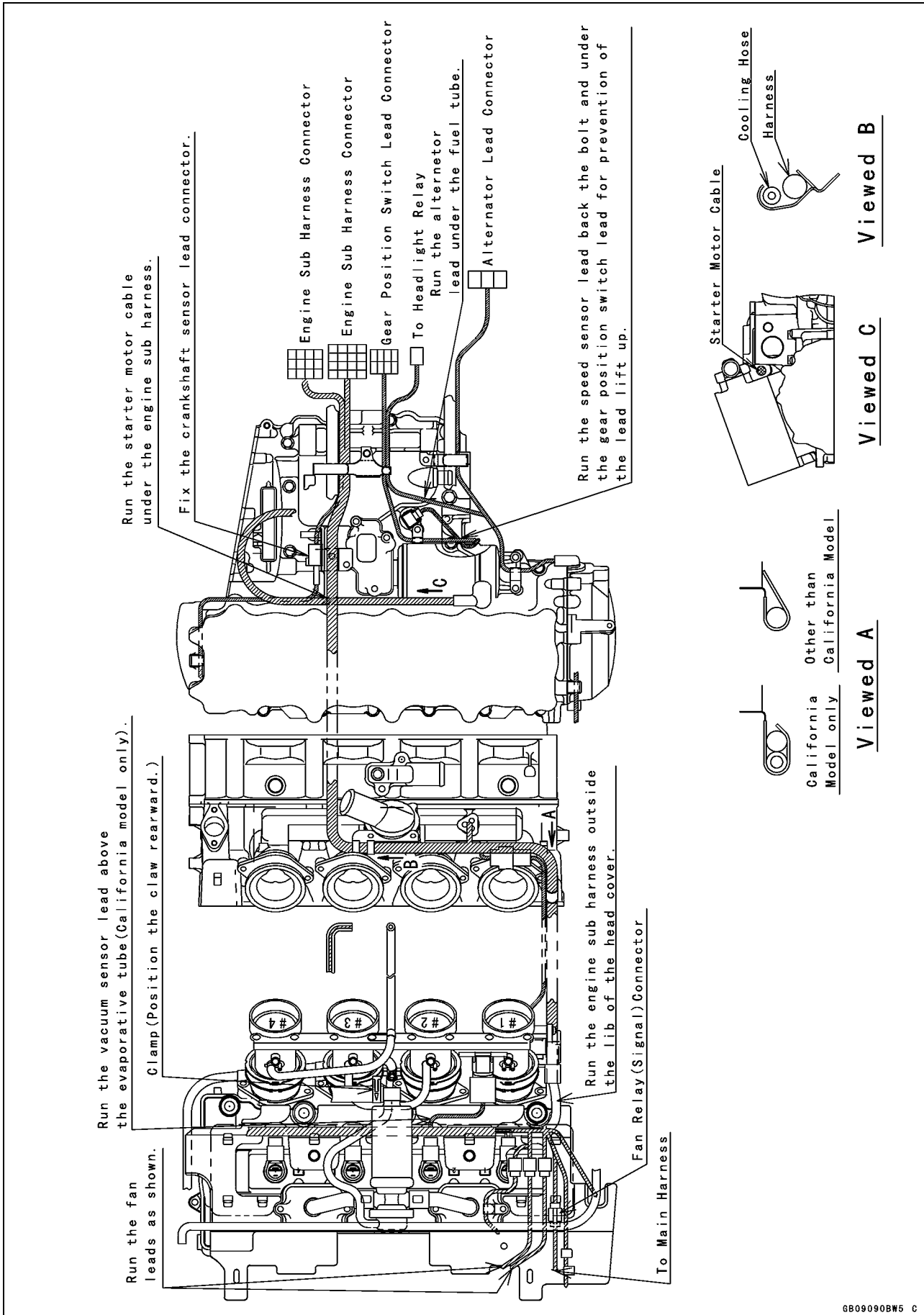

Cable, Wire, and Hose Routing (ZX1200-B1/B2)

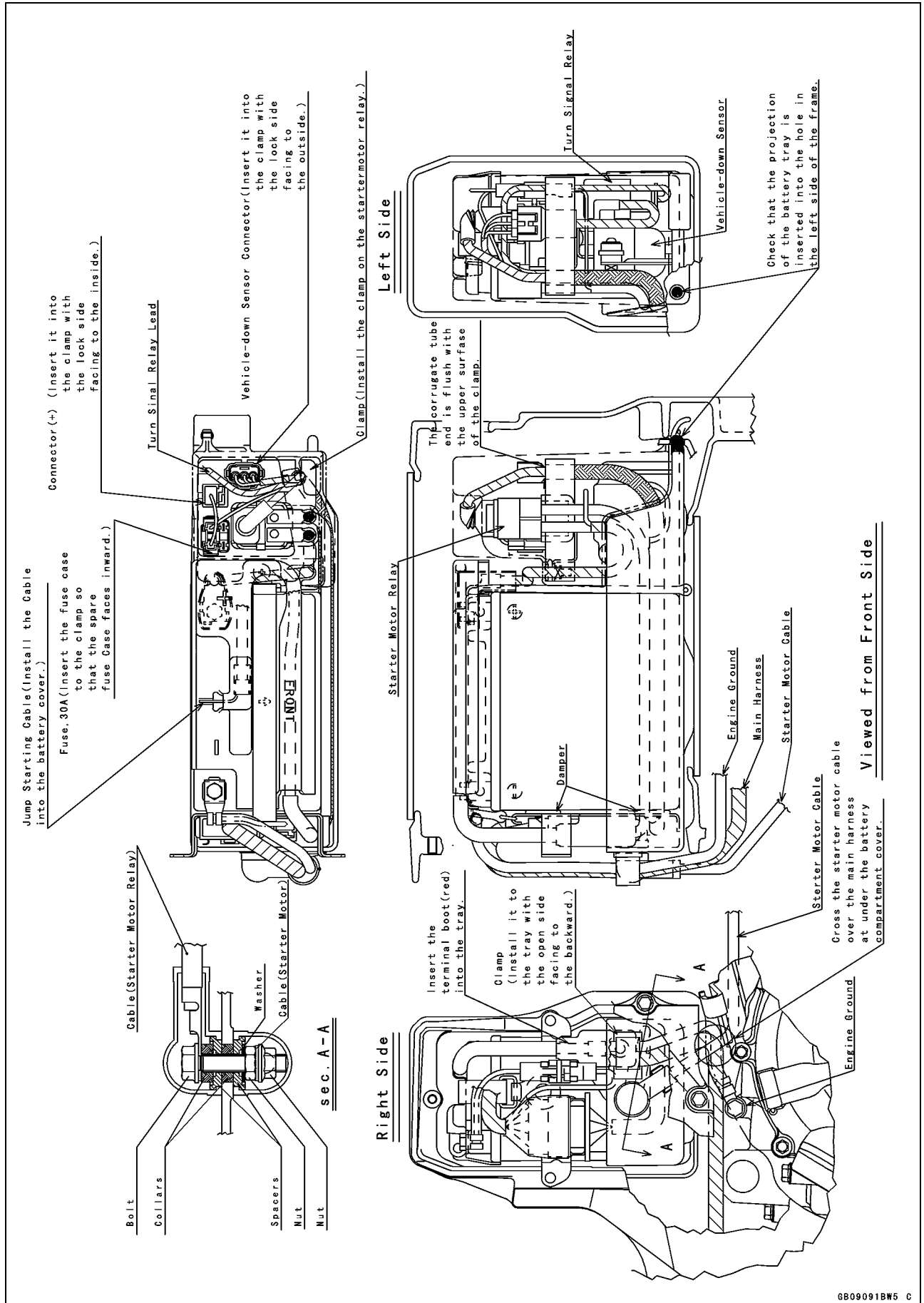

Cable, Wire, and Hose Routing (ZX1200-B1/B2)

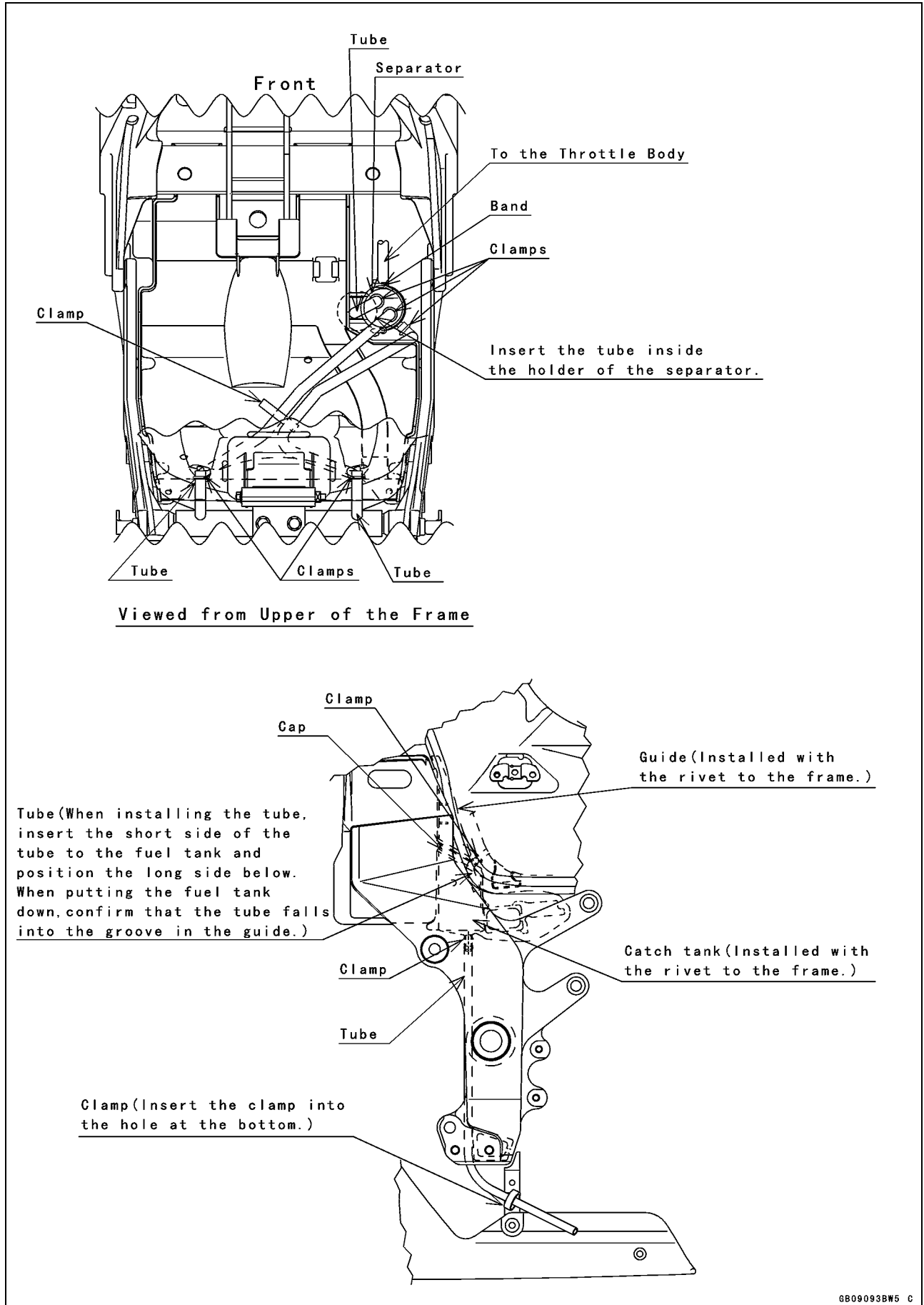

1-40 GENERAL INFORMATION

Cable, Wire, and Hose Routing (ZX1200-B1/B2)

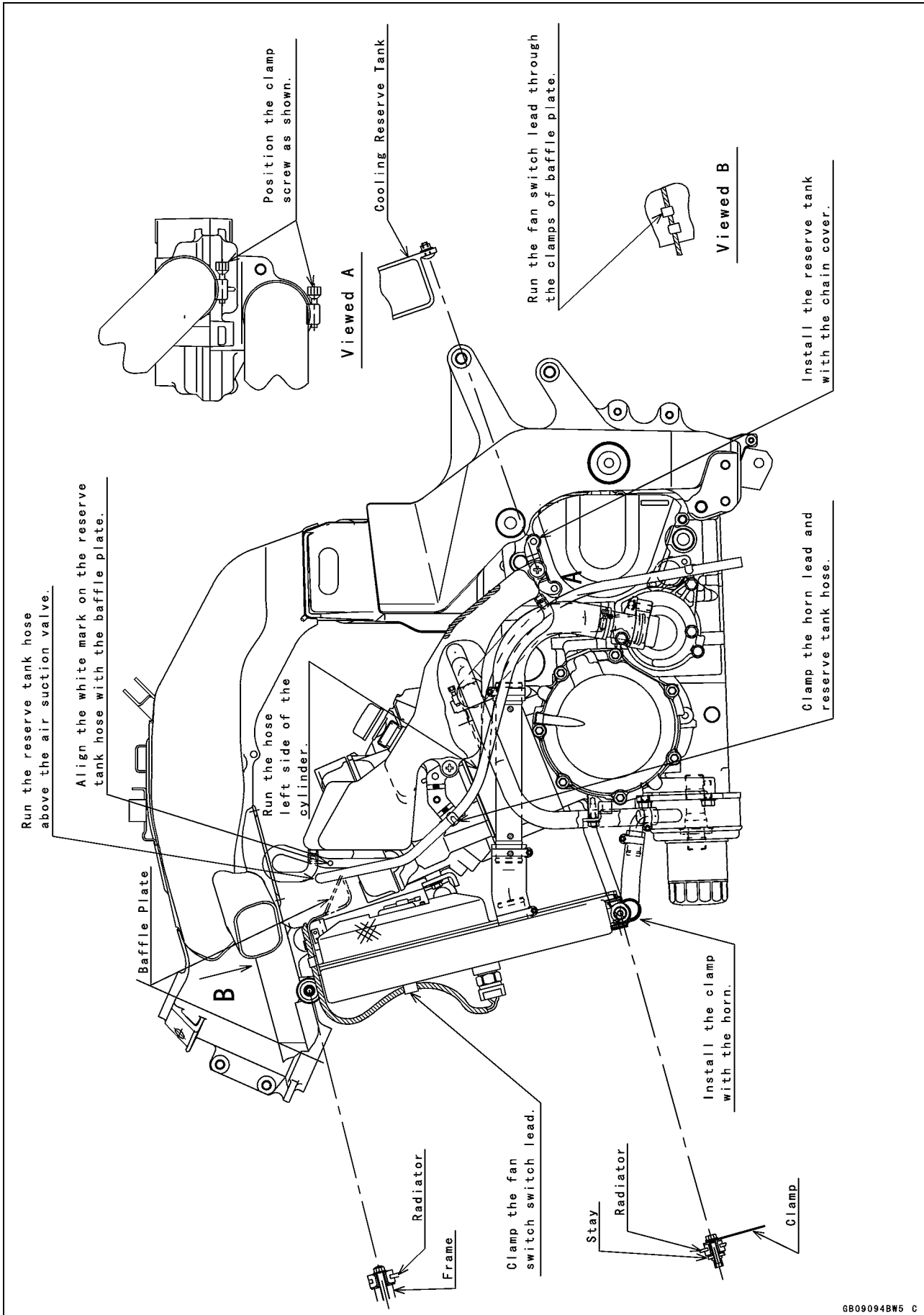

Cable, Wire, and Hose Routing (ZX1200-B1/B2)

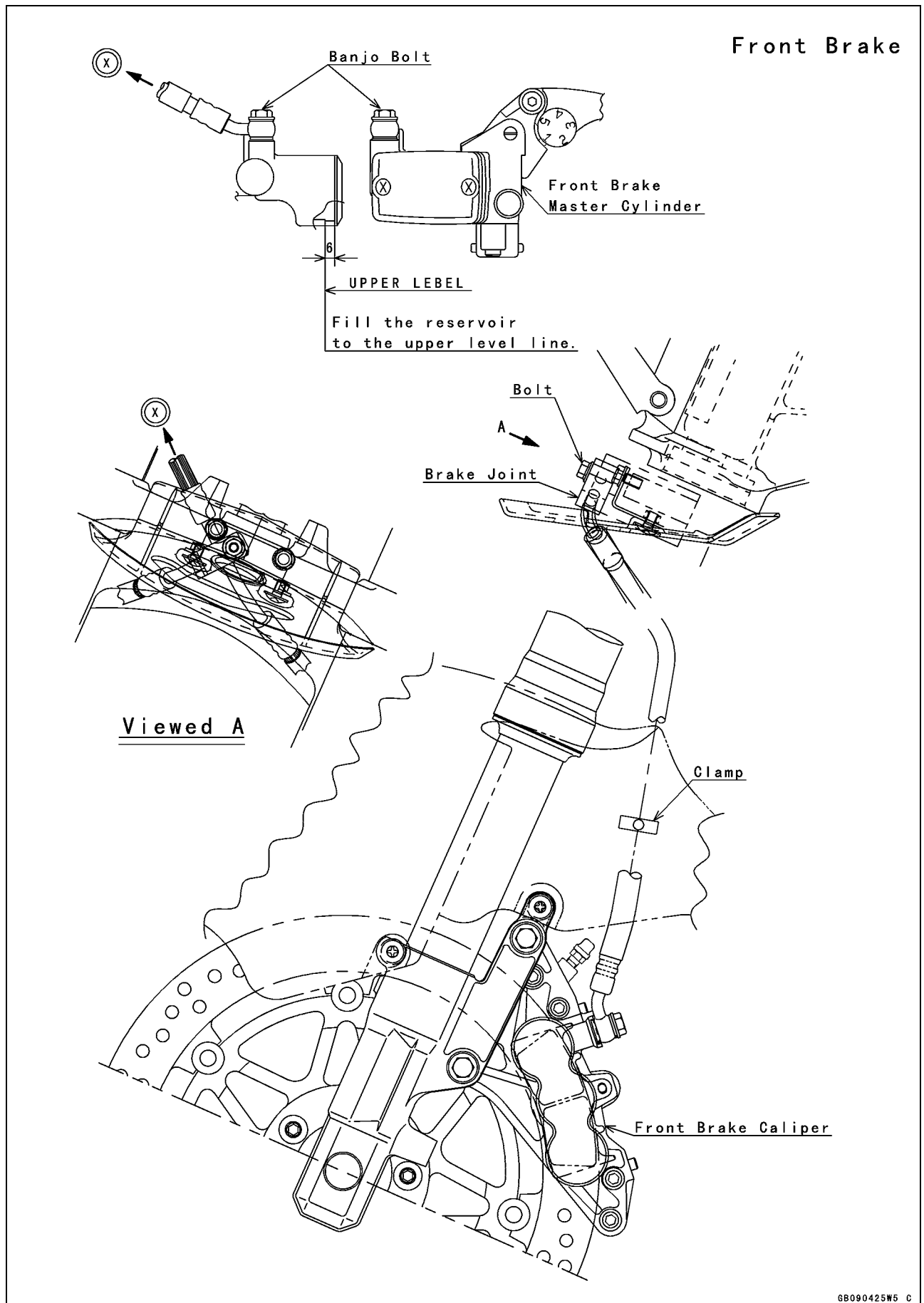

1-42 GENERAL INFORMATION

Cable, Wire, and Hose Routing (ZX1200-B1/B2)

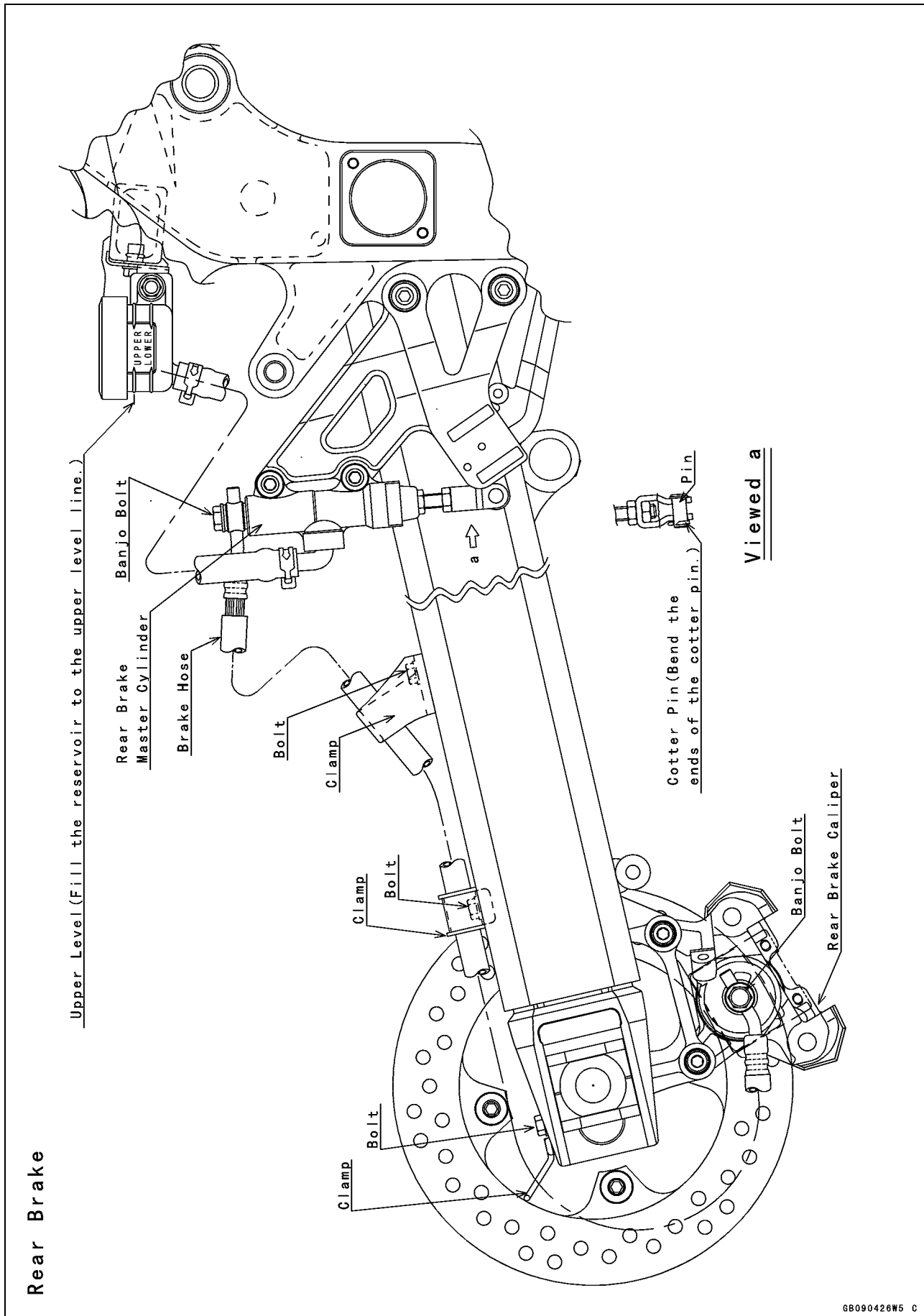

Cable, Wire, and Hose Routing (ZX1200-B1/B2)

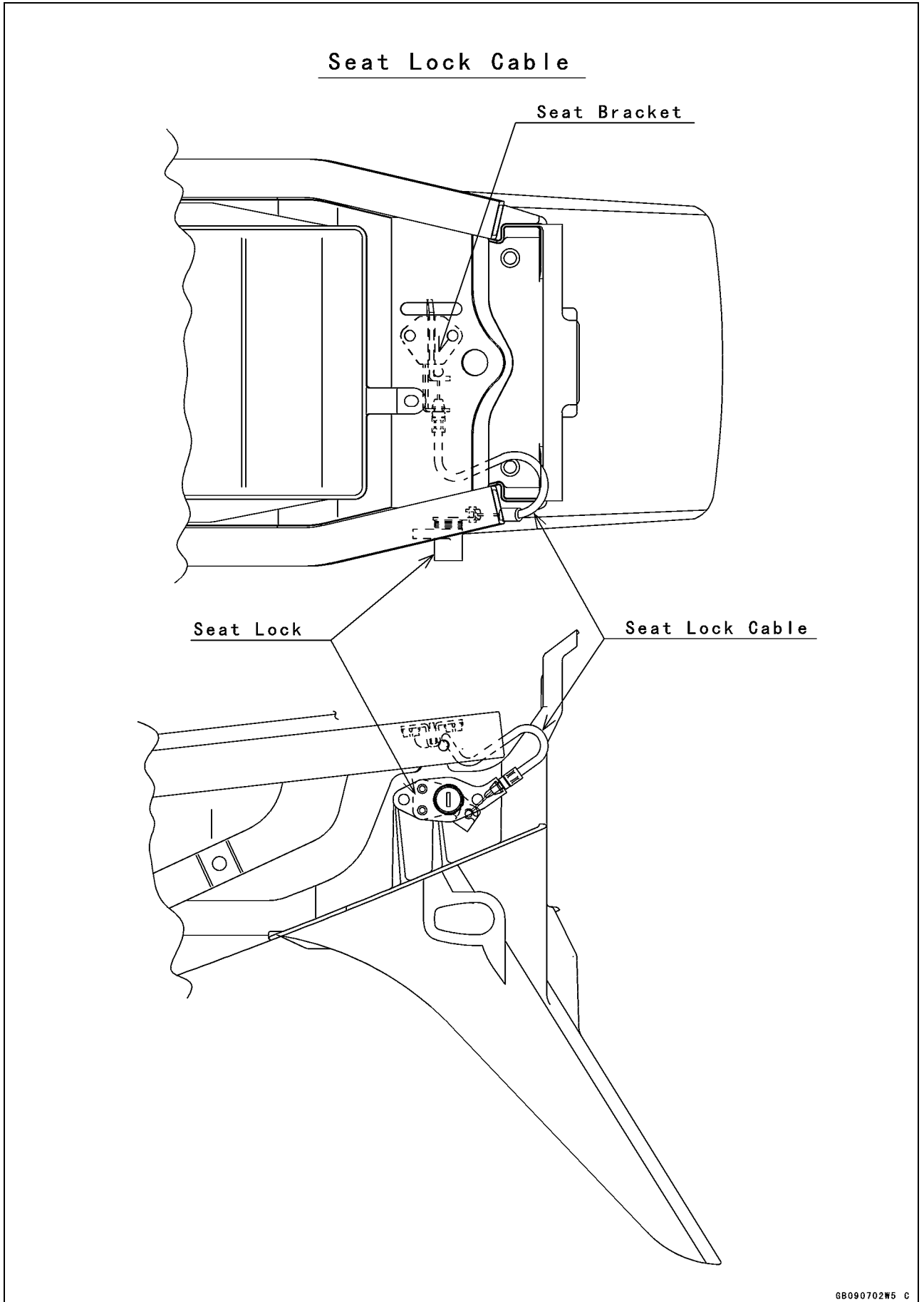

1-44 GENERAL INFORMATION

Cable, Wire, and Hose Routing (ZX1200-B1/B2)

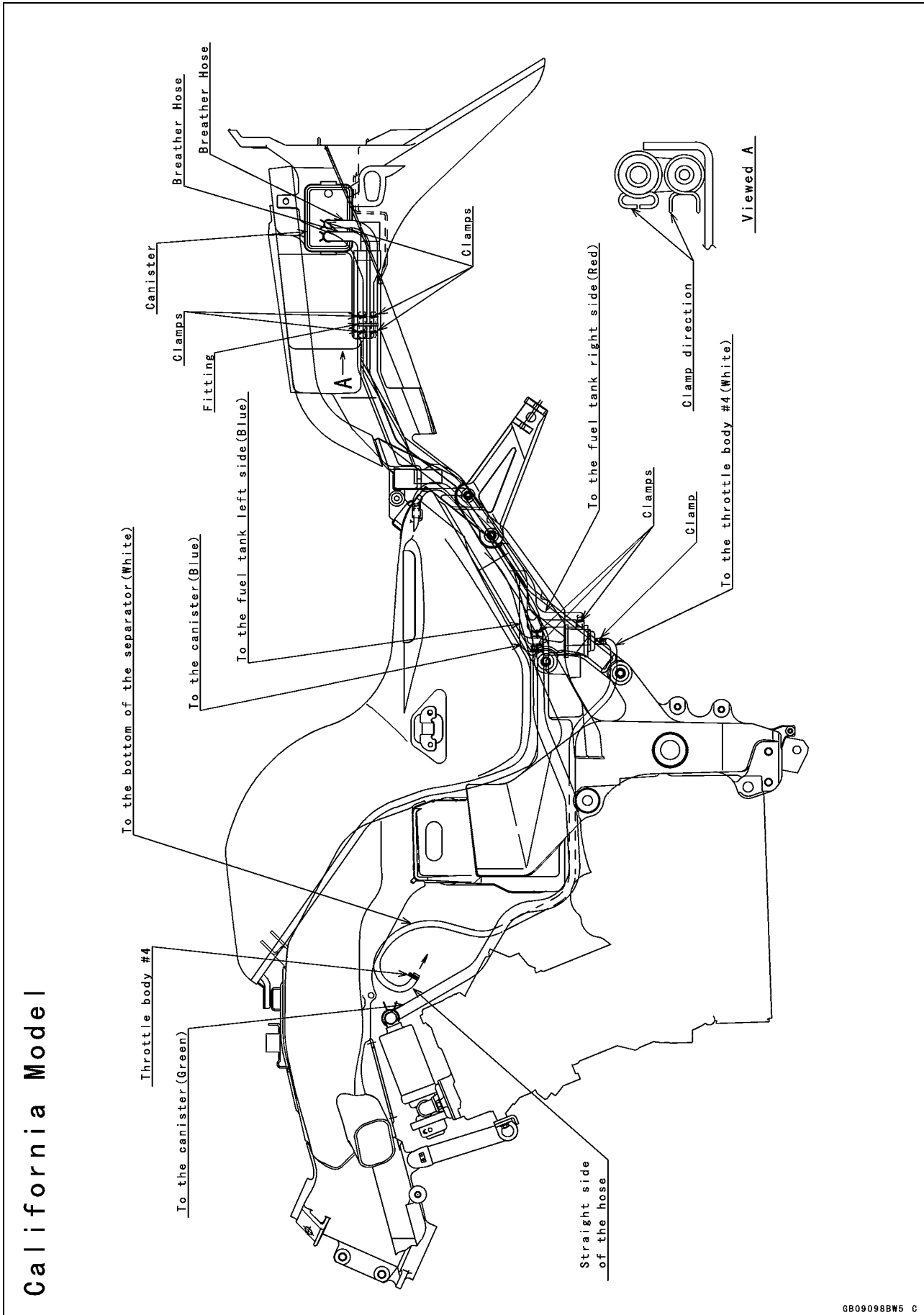

Cable, Wire, and Hose Routing (ZX1200-B1/B2)

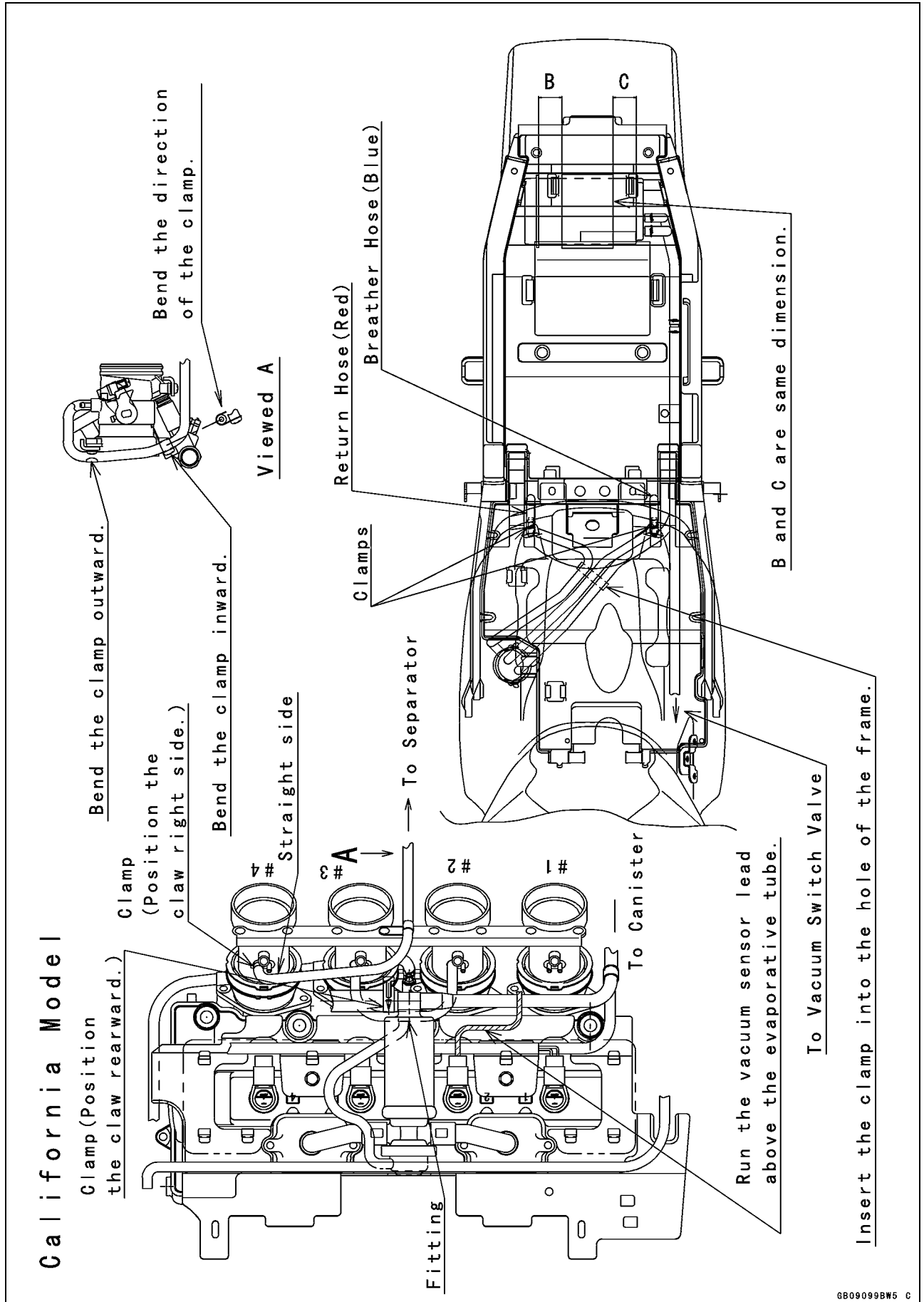

1-46 GENERAL INFORMATION

Cable, Wire, and Hose Routing (ZX1200-B3)

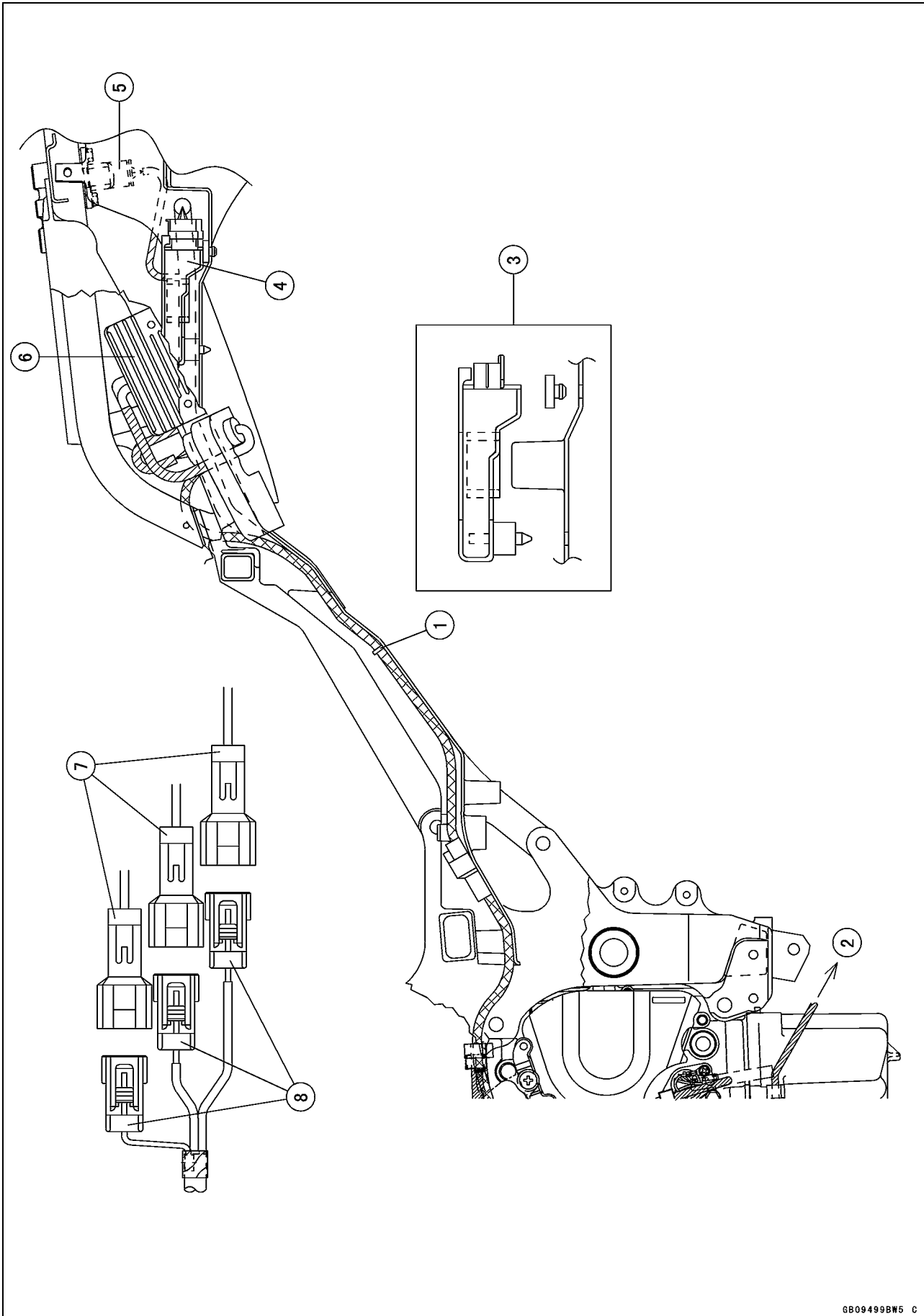

Cable, Wire, and Hose Routing (ZX1200-B3)

1. Clamp
2. To Side Stand Switch
3. Insert the dampers of the ECU into the holes of the fender.
4. ECU
5. Atmospheric Pressure Sensor
6. Regulator/rectifier
7. From Regulator/rectifier
8. From Alternator

1-48 GENERAL INFORMATION

Cable, Wire, and Hose Routing (ZX1200-B3)

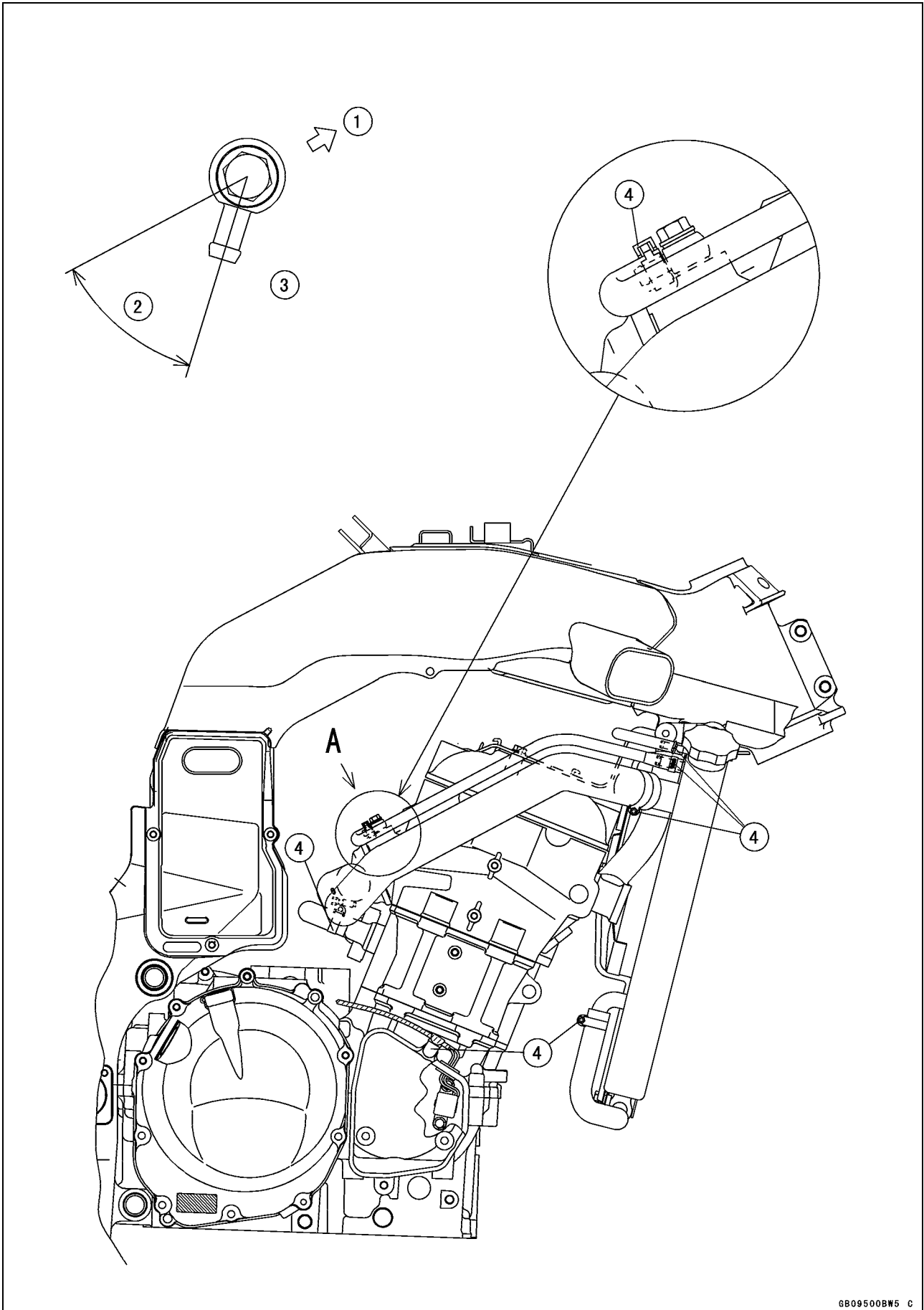

Cable, Wire, and Hose Routing (ZX1200-B3)

1. Front
2. About 45°
3. Viewed A
4. Clamp

1-50 GENERAL INFORMATION

Cable, Wire, and Hose Routing (ZX1200-B3)

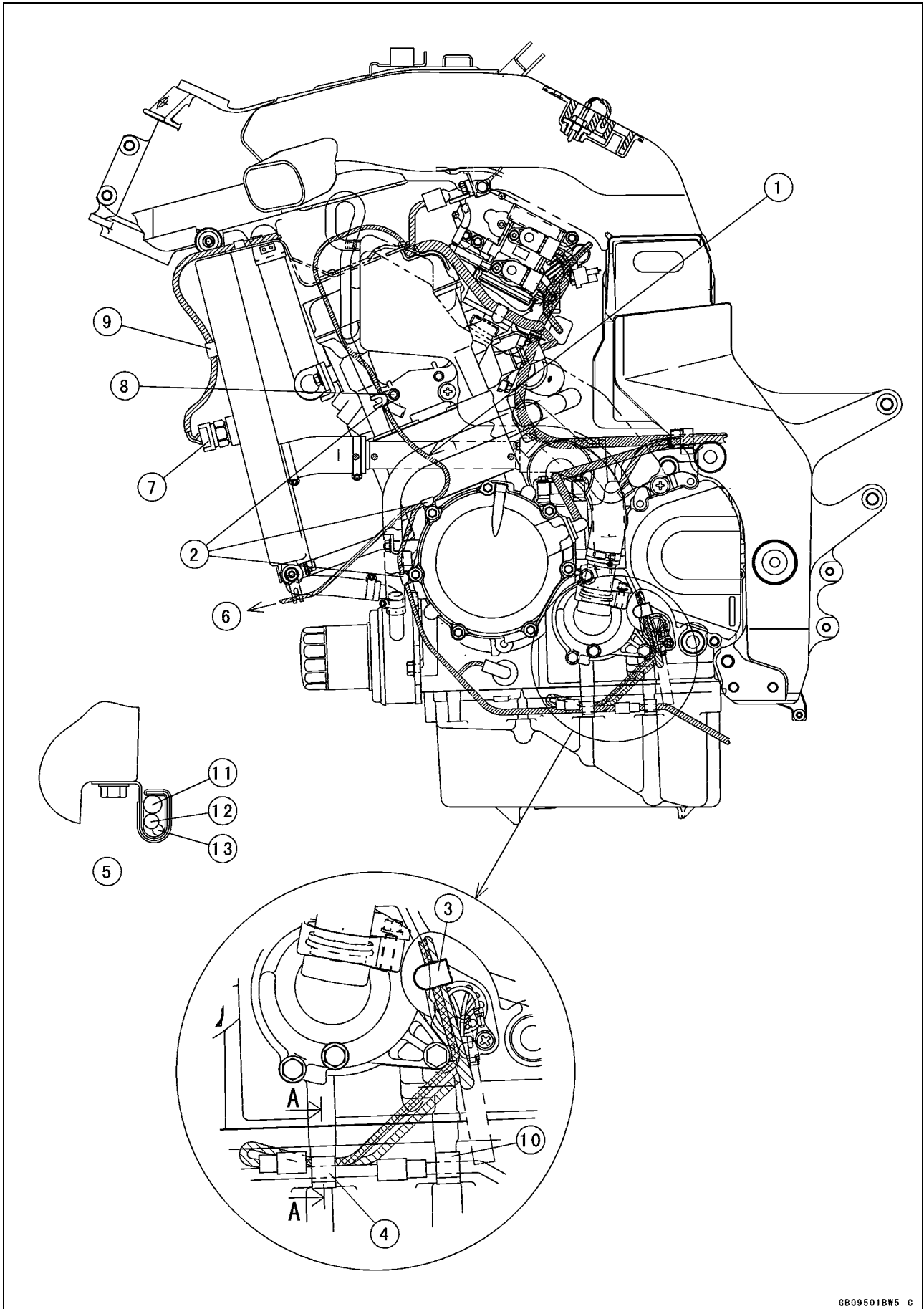

Cable, Wire, and Hose Routing (ZX1200-B3)

1. Run the horn lead between the water hose and water pipe.
2. Clamp
3. Clamp the leads so that the speed sensor lead is outside.
4. Clamp the speed sensor lead, gear position switch lead and sub harness.
5. Section A-A
6. To Horn
7. Radiator Fan Switch
8. Clamp the horn lead and reserve tank hose.
9. Clamp the fan switch lead.
10. Clamp the side stand switch lead.
11. Gear Position Switch Lead
12. Speed Sensor Lead
13. Sub Harness

1-52 GENERAL INFORMATION

Cable, Wire, and Hose Routing (ZX1200-B3)

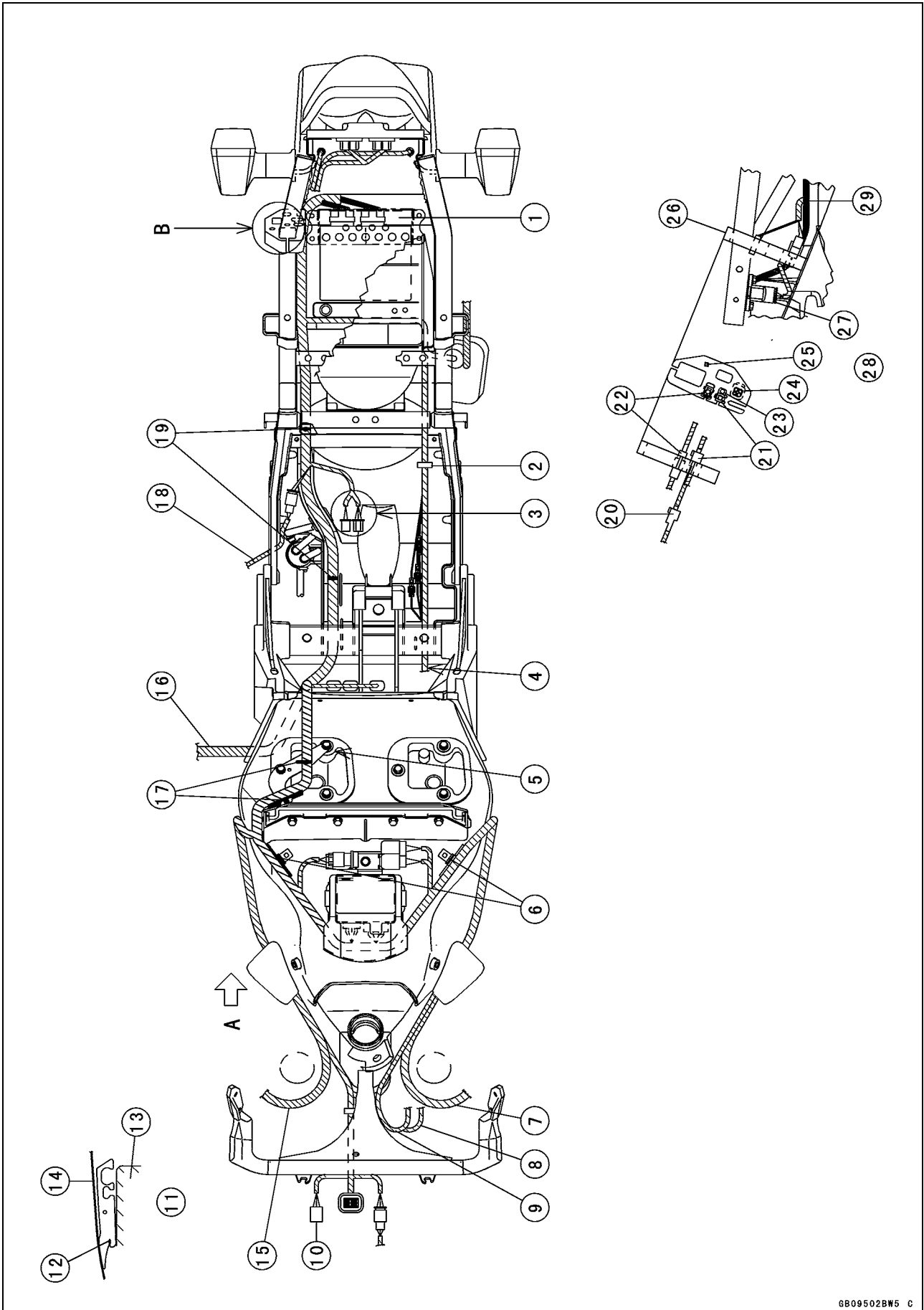

Cable, Wire, and Hose Routing (ZX1200-B3)

1. ECU Guard
2. Clamp
3. Connect the connectors of the fuel pump and fuel gauge leads.
4. To Alternator
5. Install the clamp with air cleaner cap.
6. Insert the harness into the clamps.
7. To Left Switch Housing
8. Immobilizer Antenna
9. Ignition Switch
10. Immobilizer Amplifier
11. Viewed A
12. Crankshaft Sensor Lead
13. Engine
14. Right Lower Fairing
15. To Right Switch Housing
16. To Battery Tray
17. Put the harness into the holes of the clamp.
18. To Rear Brake Light Switch
19. Put the harness into the holes of the fenders.
20. Right Turn Signal Light Connector
21. Left Turn Signal Light Connector
22. Tail/Brake Light Connector
23. Right Turn Signal Light Lead
24. Diagnosis Connector
25. Self-diagnosis Indicator Terminal
26. Clamp (Fit the clamp to the rear frame.)
27. Atmospheric Pressure Sensor Connector
28. Viewed B
29. Trim (Fit the trim to the rear fender rear.)

1-54 GENERAL INFORMATION

Cable, Wire, and Hose Routing (ZX1200-B3)

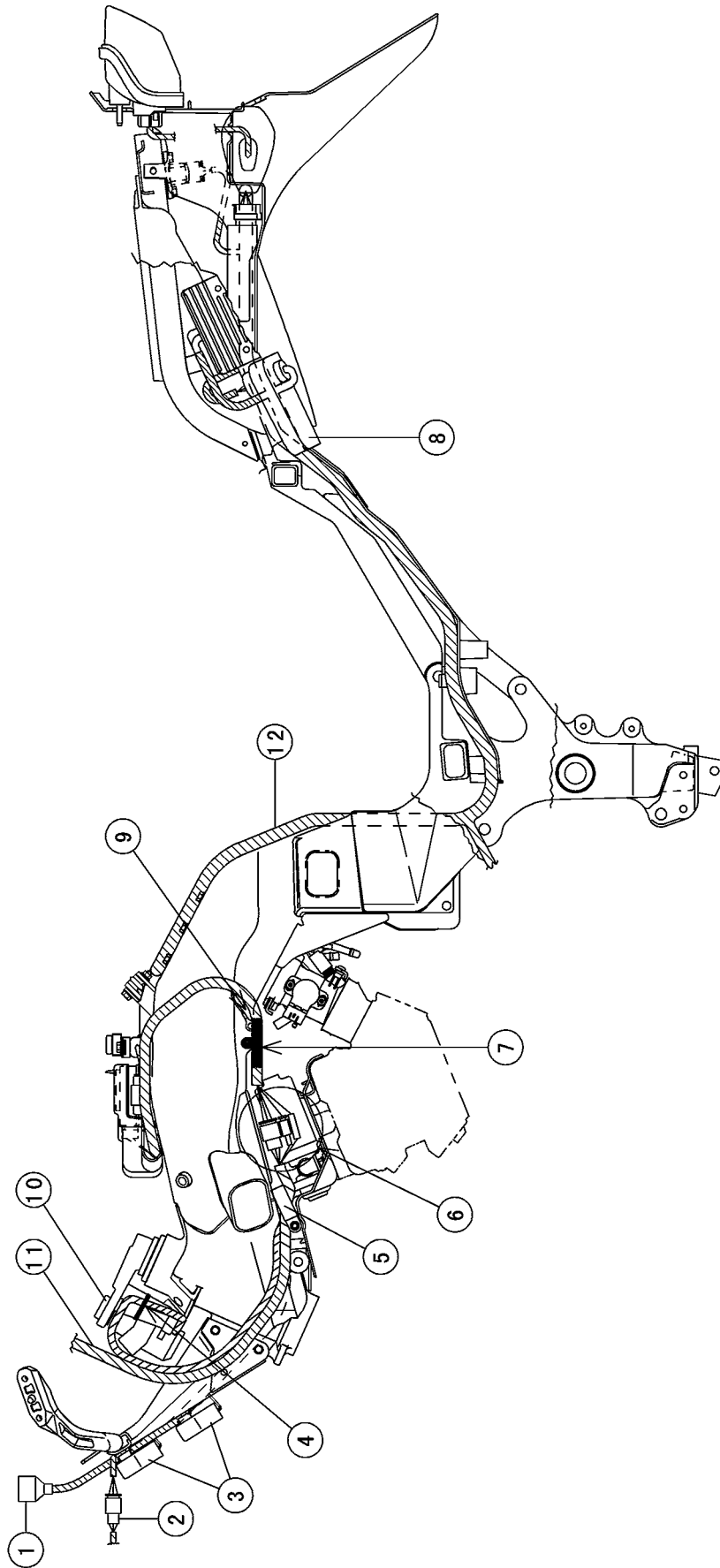

Cable, Wire, and Hose Routing (ZX1200-B3)

1. To Meter Assembly
2. Sub Harness
3. Headlight Relays
4. Band (Clamp the ignition switch lead on to the upper bracket.)
5. Clamp (Bend inside the tip of the left side clamp.)
6. Left Side (Connect the left switch housing lead connectors and ignition switch lead connectors.)
Right Side (Connect the right switch housing connectors.)
7. Insert the clamp into the hole of the frame.
8. Clamp (Fit the clamp into the rear fender rear.)
9. Frame Ground (Install the ground with the air inlet pressure sensor bracket.)
10. Ignition Switch
11. To Left Switch Housing
12. Main Harness

1-56 GENERAL INFORMATION

Cable, Wire, and Hose Routing (ZX1200-B3)

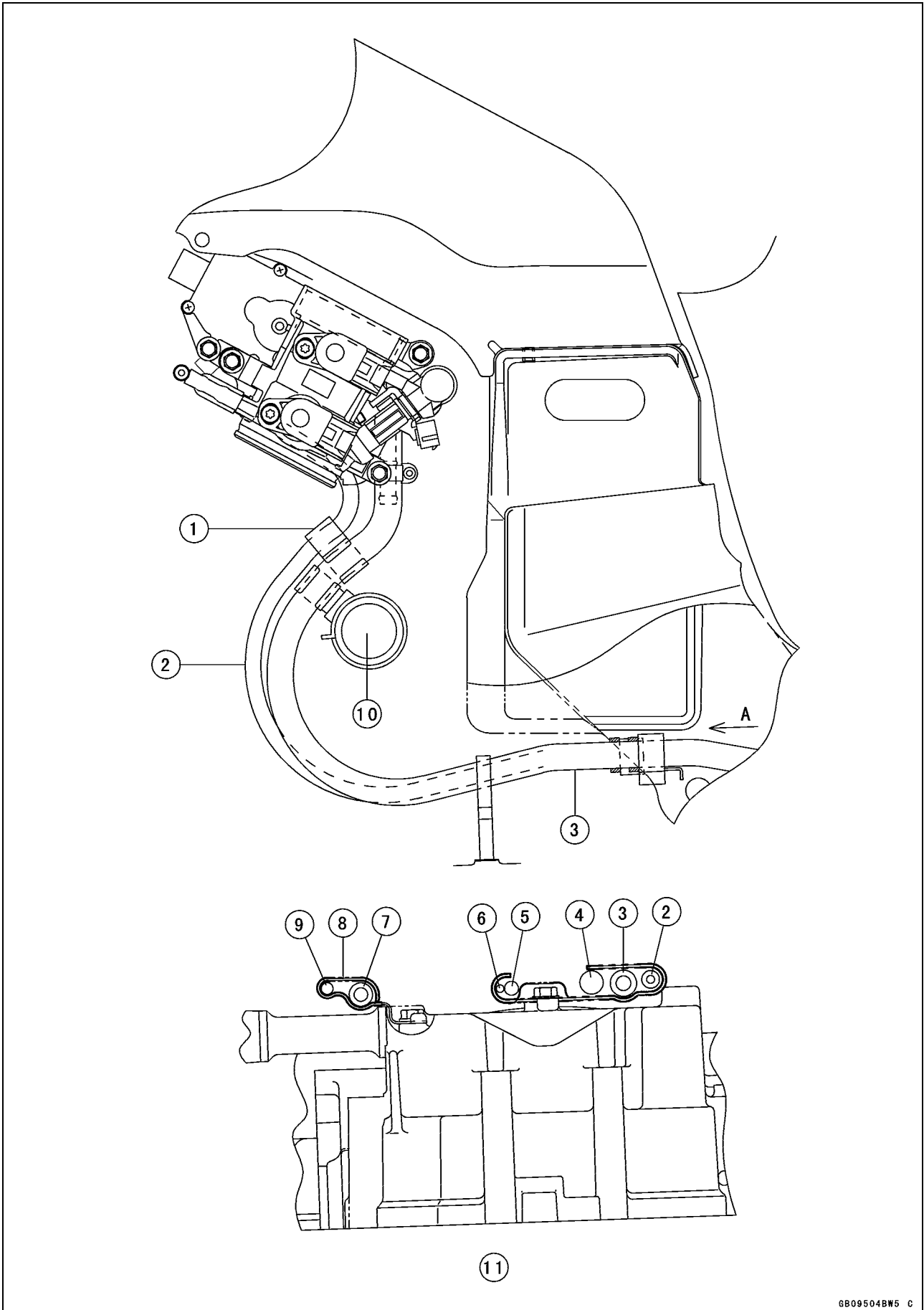

Cable, Wire, and Hose Routing (ZX1200-B3)

1. Clamp the vacuum hose and fuel hose.
2. Vacuum Hose
3. Fuel Hose
4. Engine Sub Harness
5. Gear Position Switch Lead
6. Alternator Lead
7. Tube (Air Switching Valve – Canister): California Model Only
8. Clamp
9. Alternator Lead
10. Water Hose
11. Viewed A

1-58 GENERAL INFORMATION

Cable, Wire, and Hose Routing (ZX1200-B3)

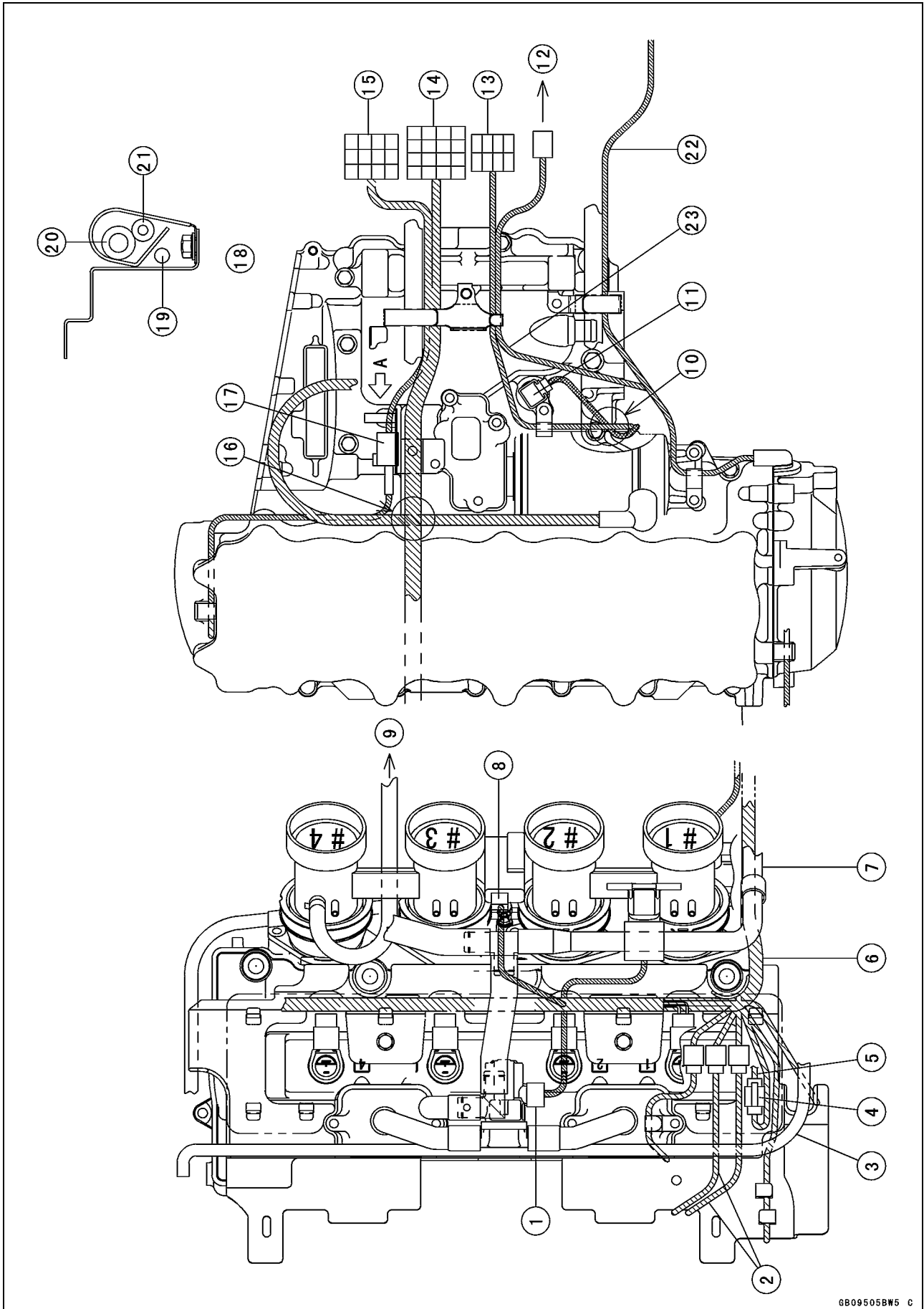

Cable, Wire, and Hose Routing (ZX1200-B3)

1. Air Switching Valve
2. Fan Leads
3. Run the water hose on the fan leads and fan switch lead.
4. Fan Relay (Signal) Connector
5. To Main Harness
6. Run the engine sub harness outside the lib of the head cover.
7. To Canister
8. Actuator
9. To Separator
10. Run the speed sensor lead back the bolt and under the gear position switch lead for prevention of the lead lift up.
11. Speed Sensor
12. To Headlight Relay
13. Gear Position Switch Lead Connector
14. Engine Sub Harness Connector
15. Engine Sub Harness Connector
16. Run the starter motor cable under the engine sub harness.
17. Fix the crankshaft sensor lead connector.
18. Viewed A
19. Crankshaft Sensor Lead
20. Fuel Hose
21. Tube (Throttle Body – Separator): California Model Only
22. Alternator Lead
23. Run the alternator lead under the fuel tube.

1-60 GENERAL INFORMATION

Unit Conversion Table

Prefixes for Units:

Prefix	Symbol	Power
mega	M	× 1 000 000
kilo	k	× 1 000
centi	c	× 0.01
milli	m	× 0.001
micro	μ	× 0.000001

Units of Mass:

kg	×	2.205	=	lb
g	×	0.03527	=	oz

Units of Volume:

L	×	0.2642	=	gal (US)
L	×	0.2200	=	gal (imp)
L	×	1.057	=	qt (US)
L	×	0.8799	=	qt (imp)
L	×	2.113	=	pint (US)
L	×	1.816	=	pint (imp)
mL	×	0.03381	=	oz (US)
mL	×	0.02816	=	oz (imp)
mL	×	0.06102	=	cu in

Units of Force:

N	×	0.1020	=	kg
N	×	0.2248	=	lb
kg	×	9.807	=	N
kg	×	2.205	=	lb

Units of Temperature:

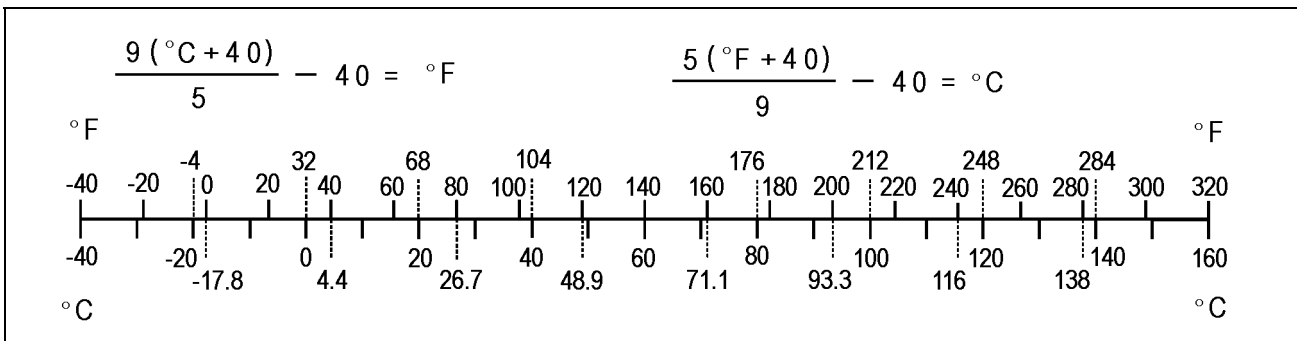

Units of Length:

km	×	0.6214	=	mile
m	×	3.281	=	ft
mm	×	0.03937	=	in

Units of Torque:

N·m	×	0.1020	=	kgf·m
N·m	×	0.7376	=	ft·lb
N·m	×	8.851	=	in·lb
kgf·m	×	9.807	=	N·m
kgf·m	×	7.233	=	ft·lb
kgf·m	×	86.80	=	in·lb

Units of Pressure:

kPa	×	0.01020	=	kgf/cm ²
kPa	×	0.1450	=	psi
kPa	×	0.7501	=	cm Hg
kgf/cm ²	×	98.07	=	kPa
kgf/cm ²	×	14.22	=	psi
cm Hg	×	1.333	=	kPa

Units of Speed:

km/h	×	0.6214	=	mph
------	---	--------	---	-----

Units of Power:

kW	×	1.360	=	PS
kW	×	1.341	=	HP
PS	×	0.7355	=	kW
PS	×	0.9863	=	HP

Periodic Maintenance

Table of Contents

Periodic Maintenance Chart	2-2	Drive Chain Lubrication.....	2-28
Specifications	2-4	Brakes.....	2-28
Periodic Maintenance Procedures....	2-6	Brake Hose, Connection	
Fuel System (DFI).....	2-6	Inspection.....	2-28
Fuel Hose and Connection		Brake Fluid Level Inspection.....	2-29
Inspection.....	2-6	Brake Fluid Change	2-29
Throttle Control System		Front Brake Pad Wear Inspection	2-30
Inspection.....	2-7	Rear Brake Pad Wear Inspection	2-31
Idle Speed Inspection	2-8	Brake/Master Cylinder Cup and	
Engine Vacuum Synchronization		Dust Seal Replace	2-31
Inspection.....	2-9	Caliper Piston/Dust Seal Replace	2-31
Air Cleaner Element Cleaning		Front Brake Light Switch	
(ZX1200-B1/B2)/Element		Inspection.....	2-31
Replacement (ZX1200-B3)	2-13	Rear Brake Light Switch	
Evaporative Emission Control		Inspection/Adjustment.....	2-31
System Inspection(CAL)	2-14	Suspension	2-32
Cooling System.....	2-15	Front Fork Oil Change	2-32
Cooling Hose and Connection		Front Fork Oil Leak Inspection....	2-42
Inspection.....	2-15	Rear Shock Absorber Oil Leak	
Coolant Change.....	2-15	Inspection.....	2-42
Engine Top End	2-17	Swingarm Pivot Lubrication	2-42
Air Suction Valve Inspection	2-17	Unit-trak Linkage Lubrication	2-43
Valve Clearance Inspection	2-18	Steering	2-43
Clutch.....	2-22	Steering Inspection	2-43
Clutch Adjust Inspection	2-22	Steering Stem Bearing	
Engine Lubrication System.....	2-23	Lubrication.....	2-45
Engine Oil Change.....	2-23	Electrical System	2-45
Oil Filter Replace	2-23	Spark Plug Cleaning and	
Wheels/Tires.....	2-24	Inspection.....	2-45
Tire Wear Inspection	2-24	General Lubrication	2-45
Final Drive.....	2-25	Lubrication Perform.....	2-45
Drive Chain Slack Inspection.....	2-25	Nut, Bolt, and Fastener Tightness ..	2-47
Drive Chain Wear Inspection	2-26	Tightness Inspection	2-47

2-2 PERIODIC MAINTENANCE

Periodic Maintenance Chart

The scheduled maintenance must be done in accordance with this chart to keep the motorcycle in good running condition. **The initial maintenance is vitally important and must not be neglected.**

OPERATION	FREQUENCY	*Odometer Reading × 1000 km (× 1000 mile)							Refer- ence
	Whichever comes first ↓ Every	1 (0.6)	6 (4)	12 (7.5)	18 (12)	24 (15)	30 (20)	36 (24)	
Steering - inspect †		•	•	•	•	•	•	•	2-43
Steering stem bearing - lubricate	2 years					•			2-45
Brake hoses, connections - inspect †			•	•	•	•	•	•	2-28
Brake fluid level - inspect †	month	•	•	•	•	•	•	•	2-29
Brake fluid - change	2 years					•			2-29
Brake pad wear - inspect † #			•	•	•	•	•	•	2-30
Brake master cylinder cup and dust seal - replace	4 years								2-31
Caliper piston seal and dust seal - replace	4 years								2-31
Brake light switches - inspect †		•	•	•	•	•	•	•	2-31
Tire wear - inspect †			•	•	•	•	•	•	2-24
Front fork oil - change	2 years					•			2-32
Front fork oil leak - inspect †				•		•		•	2-42
Rear shock absorber oil leak - inspect †				•		•		•	2-42
Swingarm pivot, Unit-track linkage - lubricate				•		•		•	2-42
Clutch adjust - inspect †		•	•	•	•	•	•	•	2-22
Drive chain slack - inspect † #	1 000 km								2-25
Drive chain wear - inspect † #			•	•	•	•	•	•	2-26
Drive chain roller wear - inspect † #			•	•	•	•	•	•	2-27
Drive chain - lubricate #	600 km								2-28
Spark plug (e) - clean and gap †			•	•	•	•	•	•	2-45
Fuel hoses, connections - inspect †			•	•	•	•	•	•	2-6
Throttle control system (e) - inspect †		•	•	•	•	•	•	•	2-7
Idle speed (e) - inspect †		•		•		•		•	2-8
Engine vacuum synchronization (e) - inspect †				•		•		•	2-9
Air cleaner element (e) - clean † # (ZX1200-B1/B2)				•		•		•	2-13
Air cleaner element (e) - replace † # (ZX1200-B3)					•				2-13
Evaporative emission control system (e) (CAL) - inspect †		•	•	•	•	•	•	•	2-14
Air suction valve (e) - inspect †			•	•	•	•	•	•	2-17
Valve clearance (e) - inspect †				•		•		•	2-18
Cooling hoses, connections - inspect †		•							2-15
Coolant - change	2 years					•			2-15

PERIODIC MAINTENANCE 2-3

Periodic Maintenance Chart

OPERATION	FREQUENCY	*Odometer Reading × 1000 km (× 1000 mile)							
	Whichever comes first ↓ Every	1 (0.6)	6 (4)	12 (7.5)	18 (12)	24 (15)	30 (20)	36 (24)	Refer- ence
Engine oil - change #	6 months	•	•	•	•	•	•	•	2-23
Oil filter - replace		•		•		•		•	2-23
General lubrication - perform				•		•		•	2-45
Nuts, bolts, and fasteners tightness - inspect †		•		•		•		•	2-47

#: Service more frequently when operating in severe conditions; dusty, wet, muddy, high speed, or frequent starting/stopping.

*: For higher odometer readings, repeat at the frequency interval established here.

†: Replace, add, adjust, clean, or torque if necessary.

CAL: California model only

e: Emission Related Items

2-4 PERIODIC MAINTENANCE

Specifications

Item	Standard	Service Limit
Fuel System (DFI)		
Throttle Grip Free Play	2 ~ 3 mm (0.08 ~ 0.12 in.)	---
Idle Speed	1 000 ±50 r/min (rpm)	---
Throttle Body Vacuum	26 ±1.333 kPa (195 ±10 mmHg)	---
Air Cleaner Element:		
ZX1200-B1/B2	Polyurethane foam	---
ZX1200-B3	Filter paper	---
Air Cleaner Element Oil	SE, SF or SG SAE 30, or High-quality air filter oil	---
Cooling System		
Coolant:		
Type (Recommended)	Permanent type antifreeze	---
Color	Green	---
Mixed Ratio	Soft water 50%, Coolant 50%	---
Freezing Point	- 35°C (- 31°F)	---
Total Amount	3.6 L (3.8 US qt)	---
Engine Top End		
Valve Clearance:		
Exhaust	0.22 ~ 0.31 mm (0.0087 ~ 0.0122 in.)	---
Inlet	0.15 ~ 0.24 mm (0.0059 ~ 0.0094 in.)	---
Clutch		
Clutch Lever Free Play	2 ~ 3 mm (0.08 ~ 0.12 in.)	---
Engine Lubrication System		
Engine Oil:		
Type	API SE, SF or SG API SH or SJ with JASO MA	---
Viscosity	SAE 10W-40	---
Capacity	2.5 L (2.6 US qt, when filter is not removed) 2.8 L (3.0 US qt, when filter is removed) 3.6 L (3.8 US qt, when engine is completely disassembled and dry)	---
Level	Between upper and lower level lines (after idling or running)	---
Tires		
Tread Depth:		
Front: DUNLOP D208FJ	4.0 mm (0.16 in.)	1 mm (0.04 in.) (AT, CH, DE): 1.6 mm (0.063 in.) Up to 130 km/h (80 mph)
Rear: DUNLOP D208J	5.4 mm (0.21 in.)	2 mm (0.08 in.) Over 130 km/h (80 mph) 3 mm (0.12 in.)

Specifications

Item	Standard	Service Limit
Air Pressure: (when Cold)		
Front	Up to 182 kg (401 lb) load: 290 kPa (2.9 kgf/cm ² , 42 psi)	---
Rear	Up to 182 kg (401 lb) load: 290 kPa (2.9 kgf/cm ² , 42 psi)	---
Final Drive		
Drive Chain Slack	25 ~ 35 mm (0.98 ~ 1.4 in.)	---
Drive Chain Roller Distance	Less than 6 mm (0.236 in.)	6.2 mm (0.244 in.)
Drive Chain 20-link Length	317.5 ~ 318.2 mm (12.50 ~ 12.53 in.)	323 mm (12.7 in.)
Brakes		
Brake Fluid:		
Grade	DOT4	---
Brake Pad Lining Thickness:		
Front and Rear	4 mm (0.12 in.)	1 mm (0.04 in.)
Brake Light Timing:		
Front	Pulled ON	---
Rear	ON after about 10 mm (0.39 in.) of pedal travel	---
Suspension		
Fork Oil:		
Viscosity	KAYABA KHL15-10 (SAE 0 W)	---
Amount (per Side):		
When Changing Oil	approx. 420 mL (14.2 US oz)	---
After Disassembly and Completely Dry	490 ±4 mL (16.6 ±0.1 US oz)	---
Fork Oil Level:	93 ±2 mm (3.66 ±0.08 in.)	---
(Fully Compressed, without Spring)	(from the top of the outer tube)	
Electrical System		
Spark Plug Gap	0.7 ~ 0.9 mm (0.028 ~ 0.035 in.)	---

AT: Republic of Austria

CH: Swiss Confederation

DE: Federal Republic of Germany

Special Tools - Steering Stem Nut Wrench: 57001-1100

Jack: 57001-1238

Oil Filter Wrench: 57001-1249

Fork Piston Rod Puller, M12 × 1.25: 57001-1289

Fork Oil Level Gauge: 57001-1290

Pilot Screws Adjuster, C: 57001-1292

Fork Spring Compressor Set: 57001-1452

Fork Spring Compressor: 57001-1587

2-6 PERIODIC MAINTENANCE

Periodic Maintenance Procedures

Fuel System (DFI)

Fuel Hose and Connection Inspection

○The fuel hoses are designed to be used throughout the motorcycle's life without any maintenance, however, if the motorcycle is not properly handled, the high pressure inside the fuel line can cause fuel to leak [A] or the hose to burst. Remove the fuel tank (see Fuel System (DFI) chapter) and check the fuel hose.

★Replace the fuel hose if any fraying, cracks [B] or bulges [C] are noticed.

- Check that the hoses are securely connected and clamps are tightened correctly.
- When installing, route the hoses according to Cable, Wire, and Hose Routing section in the General Information chapter.
- When installing the fuel hoses, avoid sharp bending, kinking, flattening or twisting, and route the fuel hoses with a minimum of bending so that the fuel flow will not be obstructed.

★Replace the hose if it has been sharply bent or kinked.

- Install the hose clamps in the position shown, and securely tighten the clamp screws to the specified torque. Check the fuel system for leaks after hose installation.

Fuel Hose [A]

Clamp [B]

Fuel Pipe [C]

18 ~ 22 mm (0.70 ~ 0.87 in.) [D]

2 ~ 3 mm (0.08 ~ 0.12 in.) [E]

- Fit the fuel hose [A] onto the pipe fully and install the plate clamp [B] beyond the raised rib [C].

1 ~ 2 mm (0.04 ~ 0.08 in.)

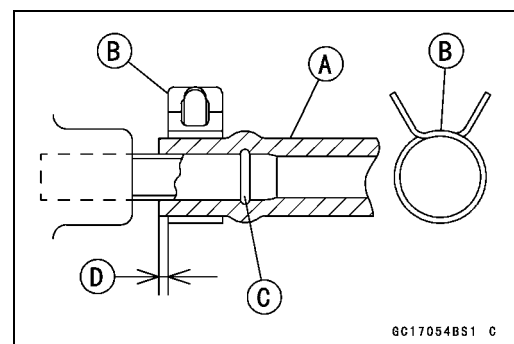
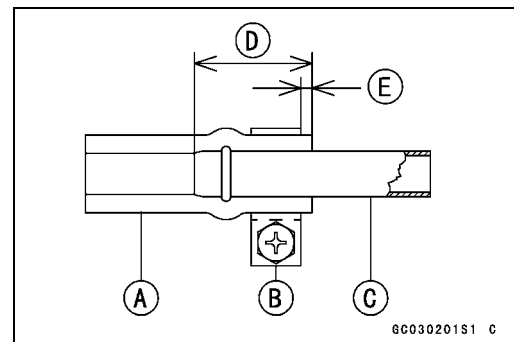
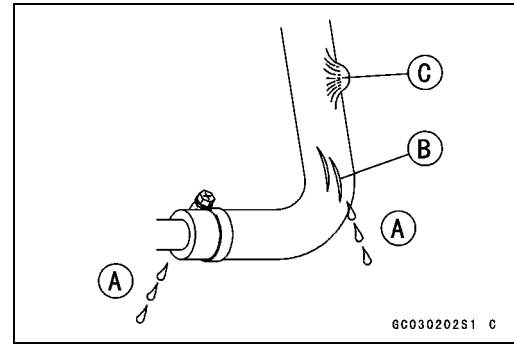

Periodic Maintenance Procedures

Throttle Control System Inspection

- Check the throttle grip free play [B].
- ★ If the free play is incorrect, adjust the throttle cables.

Throttle Grip Free Play

Standard: 2 ~ 3 mm (0.08 ~ 0.12 in.)

- Check that the throttle grip [A] moves smoothly from full open to close, and the throttle closes quickly and completely in all steering position by the return spring.
- ★ If the throttle grip does not return properly, check the throttle cables routing, grip free play, and cable damage. Then lubricate the throttle cable.
- Run the engine at the idle speed, and turn the handlebar all the way to the right and left to ensure that the idle speed does not change.
- ★ If the idle speed increase, check the throttle cable free play and the cables routing.

- Remove the right lower inner cover (see Frame chapter).
- Loosen the locknuts.
- Screw both throttle cable adjuster to give the throttle grip plenty of play.
- Completely close the throttle grip, turn the accelerator cable adjuster [A] to eliminate any cable free play, and tighten the adjuster locknut [B].
- Turn the decelerator cable adjuster [C] to adjust the throttle grip free play to 2 ~ 3 mm (0.08 ~ 0.12 in.).
- Tighten the deaccelerator cable locknut [D] securely.
- ★ If the free play cannot be adjusted with the adjusters, replace the cable.

ZX1200-B1/B2 [E]
ZX1200-B3 [F]

- Check the throttle bore for cleanliness as follows:
 - Set up the fuel tank (see Fuel System (DFI) chapter).
 - Disconnect the inlet air temperature sensor connector [A].
 - Remove:
 - Air Cleaner Cap Bolts [B]
 - Right and Left Air Cleaner Caps [C]

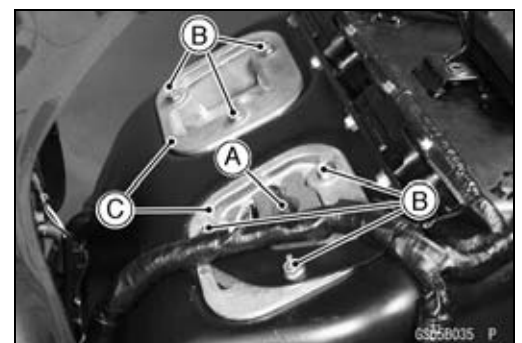
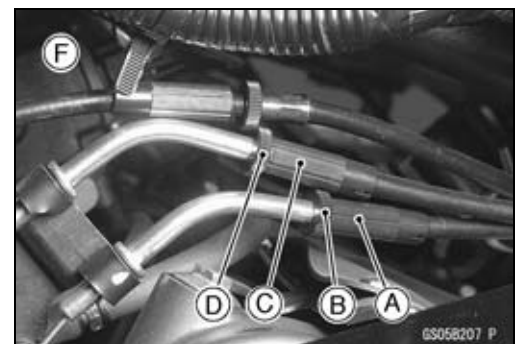
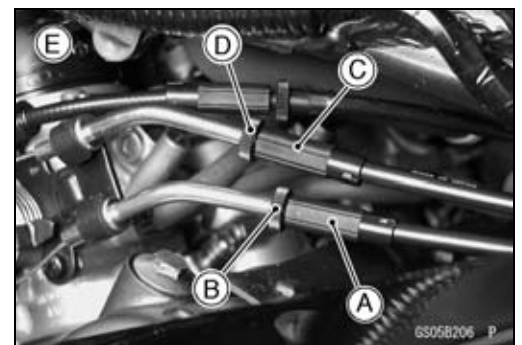
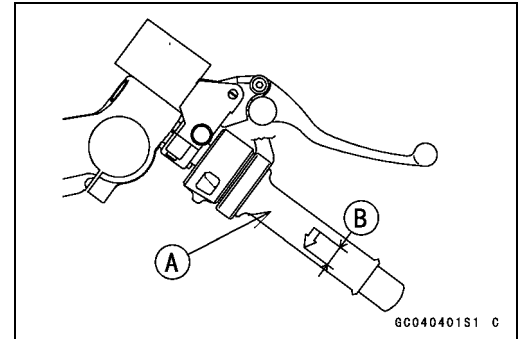

2-8 PERIODIC MAINTENANCE

Periodic Maintenance Procedures

- In accordance with the Periodic Maintenance Chart, check the throttle bores [A] at the butterfly valves [B] and around them for carbon deposits by opening the valves.
- ★ If any carbon accumulates, wipe the carbon off the throttle bores around the butterfly valves, using a lint-free cloth [C] penetrated with high-flash point solvent.

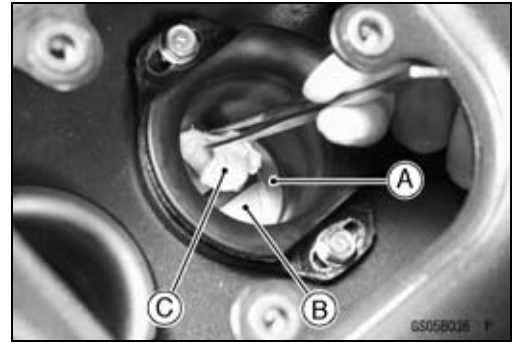

Idle Speed Inspection

- Start the engine and warm it up thoroughly.
- With the engine idling, turn the handlebar to both sides [A].
- ★ If handlebar movement changes the idle speed, the throttle cables may be improperly adjusted or incorrectly routed, or damaged. Be sure to correct any of these conditions before riding (see Cable Routing Section in General Information chapter).



⚠ WARNING

Operation with improperly adjusted, incorrectly routed, or damaged cables could result in an unsafe riding condition.

- Check the idle speed.
- ★ If the idle speed is out of specified range, adjust it.

Idle Speed

Standard: 1 000 ±50 r/min (rpm)

- Start the engine and warm it up thoroughly.
- Turn the adjusting screw [A] until the idle speed is correct.
- Open and close the throttle a few times to make sure that the idle speed is within the specified range. Readjust if necessary.

ZX1200-B1/B2 [B]

ZX1200-B3 [C]

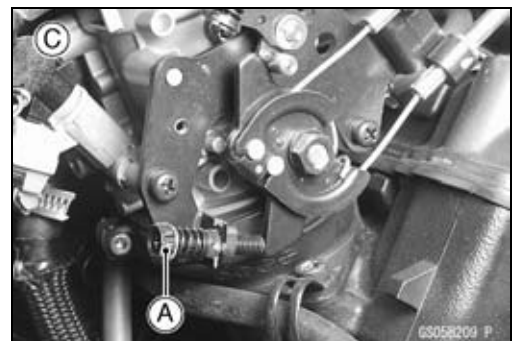
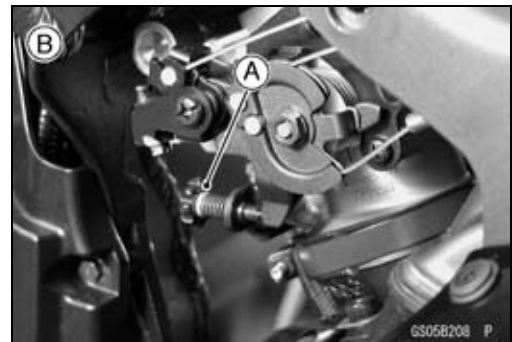

Periodic Maintenance Procedures

**Engine Vacuum Synchronization Inspection
ZX1200-B1/B2**

NOTE

○ These procedures are explained on the assumption that the inlet and exhaust system of the engine are in good condition.

- Remove the lower inner covers (see Frame chapter).
- Set up the fuel tank (see Fuel System (DFI) chapter).
- Pull out the vacuum switch valve hose [B] from the air cleaner.
- Pull off the three vacuum hoses [A] and rubber cap from the right fittings on the throttle bodies.

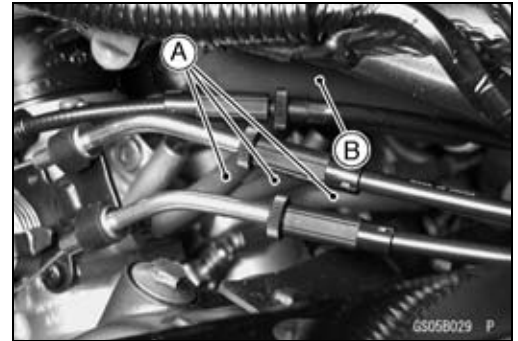

CAUTION

Do not remove the atmospheric pressure hose.

- Completely close the removed hoses [A] and [B] of the clean air system with the proper plugs.
- Completely close the clean air system hole of the air cleaner with the proper plug.

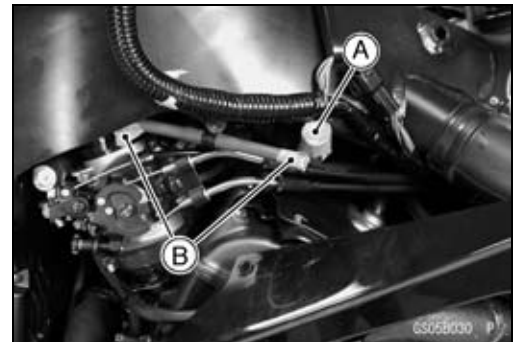

- Start the engine and warm it up thoroughly.
- Check the engine speed, using the engine revolution tester [A] for high accuracy.
- ★ If the engine speed is out of 1 000 rpm, set the engine speed to 1 000 rpm.

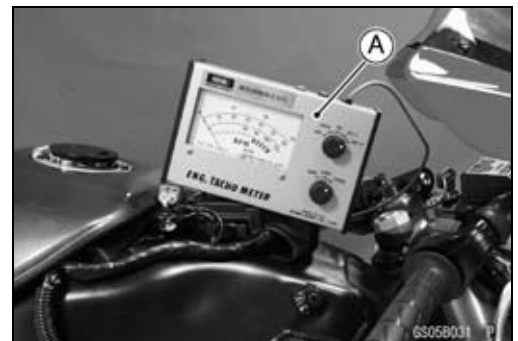

CAUTION

Do not adjust the engine speed by the tachometer in the meter unit.

- Connect the vacuum gauge hoses [A] to the right fittings on the throttle bodies.
- Connect the vacuum gauge hoses to the vacuum gauge [B].
- Start the engine and left it idle to measure the inlet vacuum.
- ★ If the vacuum is incorrect, adjust the synchronization.

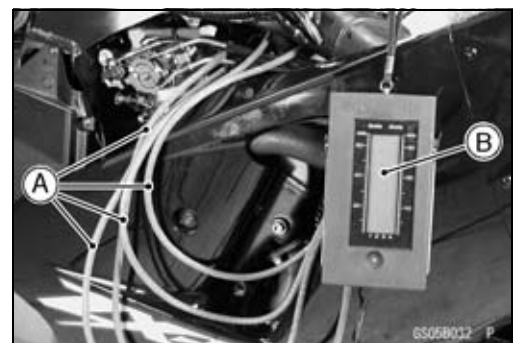

Engine Vacuum

Standard: 26 ±1.333 kPa (195 ±10 mmHg) at Idle Speed 1 000 ±50 r/min (rpm)

2-10 PERIODIC MAINTENANCE

Periodic Maintenance Procedures

- Turn the adjusting screw [A] to synchronize the throttle valves.
- First synchronize the left two or the right two throttle valves by means of the left and right adjusting screws. Then synchronize the left two throttle valves and the right two throttle valves using the center adjusting screw.
- ★ If the throttle valves synchronization cannot be obtained by using the adjusting screws, check for dirt or blockage, and then check the inlet parts connection.

Special Tool - Pilot Screw Adjuster, C: 57001-1292 [B]

- Check the throttle valve synchronization again

NOTE

○ Do not turn the bypass screws [A] carelessly during throttle valve synchronization. You may cause poor running at low engine speed or irregular throttle sensor output voltage.

- Remove the vacuum gauge hoses and install the removed parts.
- Check the idle speed.

ZX1200-B3

NOTE

○ These procedures are explained on the assumption that the inlet and exhaust systems of the engine are in good condition.

- Situate the motorcycle so that it is vertical.
- Remove the lower inner covers (see Frame chapter).
- Set up the fuel tank (see Fuel System (DFI) chapter).
- Pull off the vacuum hoses [A] and rubber cap(s) from the right fittings of each throttle body.
- Pull off the air switching valve hose [B] from the air cleaner housing.

CAUTION

Do not remove the atmospheric pressure hose.

- Plug:
Air Switching Valve Hose [A] and its Air Cleaner Housing Hole

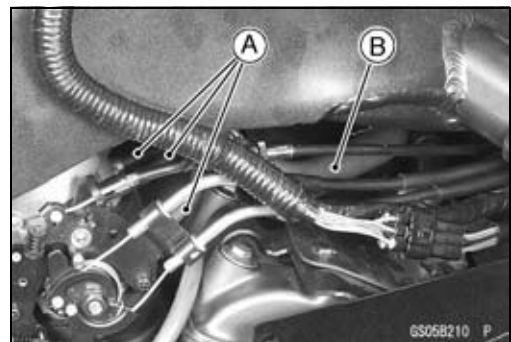
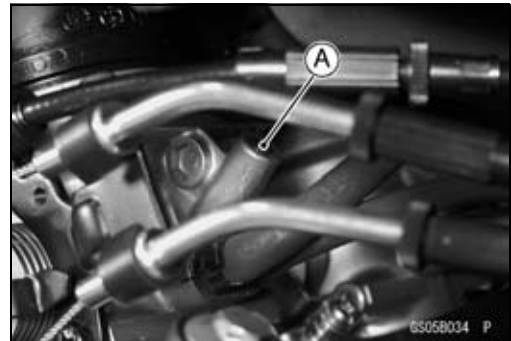
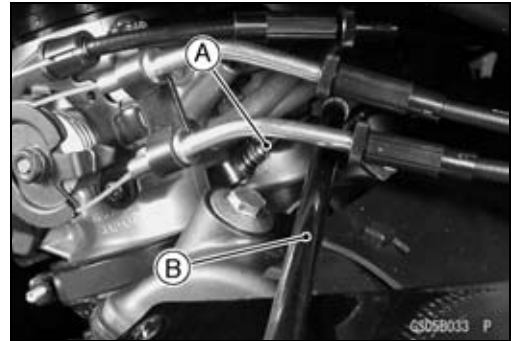

Periodic Maintenance Procedures

- Start the engine and warm it up thoroughly.
- Check the idle speed.
Tachometer [A]
- Open and close the throttle.
- ★ If the idle speed is out of the specified range, adjust it.

CAUTION

Do not measure the idle speed by the tachometer of the meter unit.



- Connect a commercially available vacuum gauge [A] to these right fittings of the throttle body.
- While idling the engine, inspect the engine vacuum, using the vacuum gauge.

Engine Vacuum

Standard: **26 ±1.333 kPa (195 ±10 mmHg) at Idle Speed 1 000 ±50 r/min (rpm)**

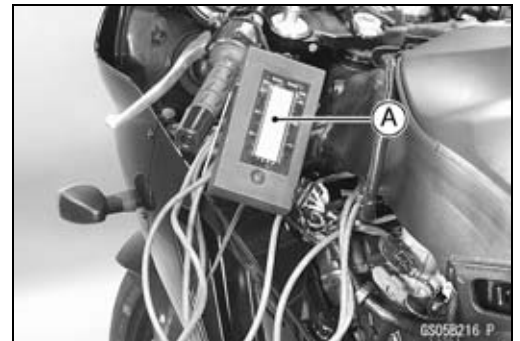

- ★ If any vacuum is not within the specifications, first synchronize the balance of the left (#1, #2) and right (#3, #4) assemblies.

Example:

- #1: 165 mmHg
- #2: 190 mmHg
- #3: 170 mmHg
- #4: 200 mmHg

- With the engine at the correct idle speed, equalize the lower vacuum of #1 and #2 (example 165 mmHg) to the lower vacuum of #3 and #4 (example 170 mmHg) by turning the center adjusting screw [A].

Special Tool - Pilot Screw Adjuster, C: 57001-1292

Front [B]

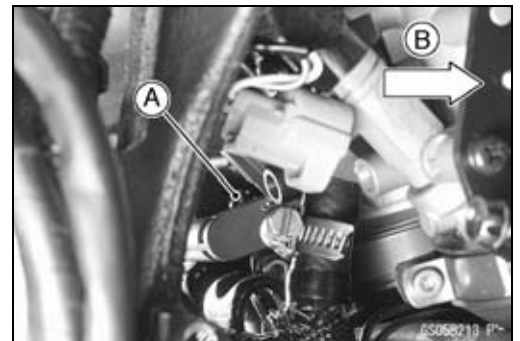

NOTE

○ After adjustment, the final vacuum measurement between the lowest throttle valves may not be 165 mmHg (in this example). The goal is to have the lower two vacuums between the left (1 and 2) and right (3 and 4) banks be the same.

- Open and close the throttle after each measurement and adjust the idle speed as necessary.
- Once the throttle valves have been synchronized, inspect the main throttle sensor's output voltage to ensure proper operation (procedure is at the end of this section).

2-12 PERIODIC MAINTENANCE

Periodic Maintenance Procedures

★If any one vacuum measurement is out of the standard measurement after left and right synchronization, turn in the bypass screw [A] until it seat fully but not tightly.

CAUTION

Do not over tighten them. They could be damaged, requiring replacement.

- Turn out the bypass screw of the higher vacuum between #1 and #2 to the lower vacuum.
- Turn out the bypass screw of the higher vacuum between #3 and #4 to the lower vacuum.
- Open and close the throttle valves after each measurement and adjust the idle speed as necessary.
- Inspect the vacuums as before.
- ★If all vacuums are within the specification, finish the engine vacuum synchronization.
- ★If any vacuum can not be adjusted within the specification, remove the bypass screws #1 ~ #4 and clean them.

- Remove the bypass screw [A], spring [B], washer [C] and O-ring [D].

○Check the bypass screw and its hole for carbon deposits.

★If any carbon accumulates, wipe the carbon off the bypass screw and the hole, using a cotton pad penetrated with a high-flash point solvent.

○Replace the O-ring with a new one.

○Check the tapered portion [E] of the bypass screw for wear or damage.

★If the bypass screw is worn or damaged, replace it.

- Turn in the bypass screw until it seats fully but not tightly.

- Repeat the same procedure for other bypass screws.

- Repeat the synchronization.

★If the vacuums are correct, check the output voltage of the main throttle sensor (see Output Voltage Inspection of Main Throttle Sensor in the Fuel System (DFI) chapter).

Main Throttle Sensor Output Voltage

Connections to ECU

Meter (+) → Y/W lead (terminal 7)

Meter (-) → BR/BK lead (terminal 28)

Standard:

1.06 ~ 1.10 V DC (at idle throttle opening)

★If the output voltage is out of the range, check the throttle input voltage (see Input Voltage Inspection of Main Throttle Sensor in the Fuel System (DFI) chapter).

- Remove the vacuum gauge hoses and install the vacuum hoses and rubber caps on the original position as shown.

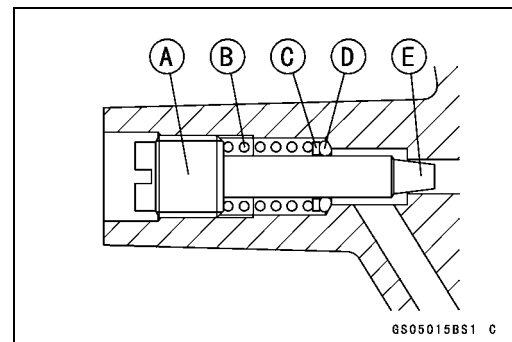
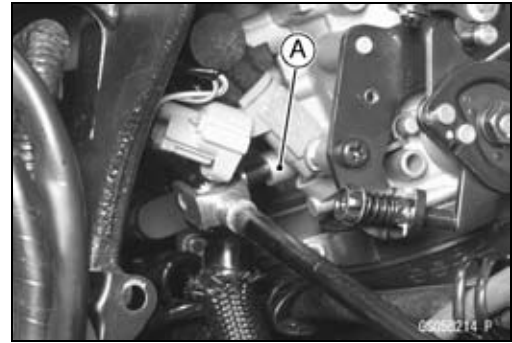

Periodic Maintenance Procedures

*Air Cleaner Element Cleaning (ZX1200-B1/B2)/
Element Replacement (ZX1200-B3)*

NOTE

- *In dusty areas, the element should be cleaned more frequently than the recommended interval.*
- *After riding through rain or on muddy roads, the element should be cleaned immediately.*

⚠ WARNING

If dirt or dust is allowed to pass through into the throttle assy, the throttle may become stuck, possibly causing accident.

CAUTION

If dirt gets through into the engine, excessive engine wear and possibly engine damage will occur.

⚠ WARNING

Clean the element in a well-ventilated area, and take care that there are no sparks or flame anywhere near the working area; this includes any appliance with a pilot light.

Because of the danger of highly flammable liquids, do not use gasoline or a low flash-point solvent to clean the element.

- Remove:
 - Seats (see Frame chapter)
 - Fuel Tank Cover (see Fuel Tank Removal section in Fuel System (DFI) chapter)
- Set up the fuel tank [A] with the supporting rod [B].

CAUTION

Do not insert the supporting rod into the bolt hole, or the thread of the bolt hole could be damaged.

- Unscrew the nuts [A] and remove the bolts.
- Pull out the elements [B].

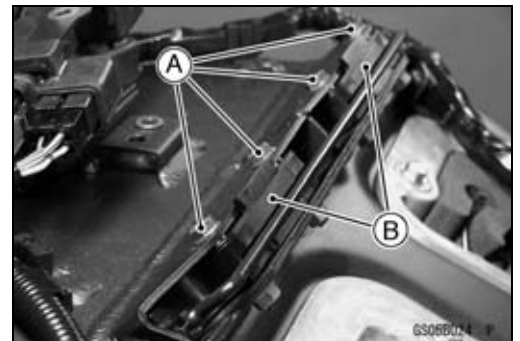
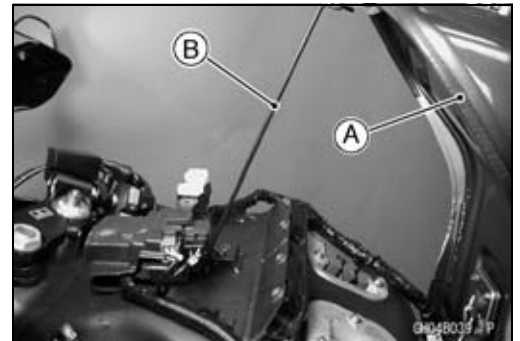

2-14 PERIODIC MAINTENANCE

Periodic Maintenance Procedures

ZX1200-B1/B2

- Clean the element [A] in cleaning solvent, and then dry it with compressed air or by shaking it.
- After cleaning, saturate a clean, lint-free towel with SE, SF, SG class SAE-30 oil or high-quality air filter oil, and apply the oil to the element by tapping the element outside with the towel.
- Inspect the element before installing it.
- ★ If the element is broken, or the frame is damaged or bent, replace the element.

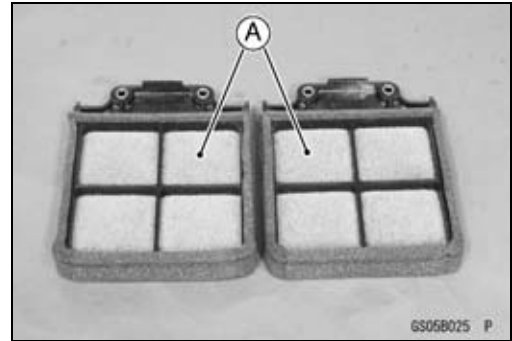

ZX1200-B3

- Discard the air cleaner elements.
Air Cleaner Elements [A]

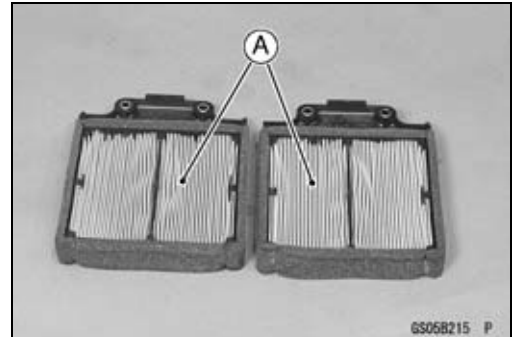

- Install the elements [A] with the mark side (FRONT) facing front.

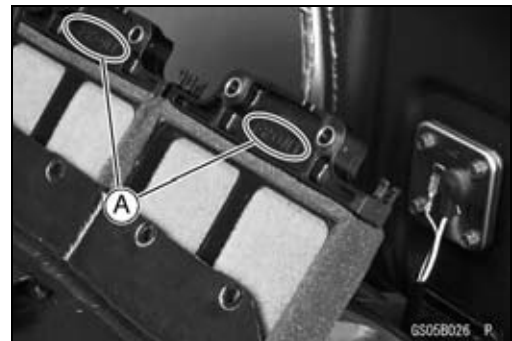

Evaporative Emission Control System Inspection (CAL)

- Inspect the canister as follows.
 - Remove:
 - Seats (see Frame chapter)
 - Storage Box (see Frame chapter)
 - Remove the canister [A], and disconnect the hoses from the canister.
 - Visually inspect the canister for cracks and other damage.
 - ★ If the canister has any cracks or bad damage, replace it with a new one.



NOTE

- The canister is designed to work well through the motorcycle's life without any maintenance if it is used under normal conditions.

Periodic Maintenance Procedures

- Check the liquid/vapor separator as follows:
 - Remove:
 - Seat (see Frame chapter)
 - Fuel Tank Cover (see Fuel Tank Removal section in Fuel System (DFI) chapter)
 - Supporting Rod (see Fuel Tank Removal section in Fuel System (DFI) chapter)
 - Disconnect the hoses from the separator, and remove the separator [A] from the motorcycle right side.
 - Visually inspect the separator for cracks and other damage.
- ★ If the separator has any cracks or damage, replace it with a new one.
 - To prevent the gasoline from flowing into or out of the canister, hold the separator perpendicular to the ground.
- Check the hoses of the evaporative emission control system as follows:
 - Check that the hoses are securely connected and clips are in position.
 - Replace any kinked, deteriorated or damaged hoses.
 - Route the hoses according to Cable, Wire, and Hose Routing section in the General Information chapter. Refer to the diagram of the evaporative emission control system in the Fuel System (DFI) chapter too.
 - When installing the hoses, avoid sharp bending, kinking, flattening or twisting, and route the hoses with a minimum of bending so that the emission flow will not be obstructed.



Cooling System

Cooling Hose and Connection Inspection

- The high pressure inside the cooling hose can cause coolant to leak [A] or the hose to burst if the line is not properly maintained. Visually inspect the hoses for signs of deterioration. Squeeze the hoses. A hose should not be hard and brittle, nor should it be soft or swollen.
- ★ Replace the hose if any fraying, cracks [B] or bulges [C] are noticed.
- Check that the hoses are securely connected and clamps are tightened correctly.

Torque - Cooling Hose Clamp Screws: 2.0 N·m (0.20 kgf·m, 18 in·lb)

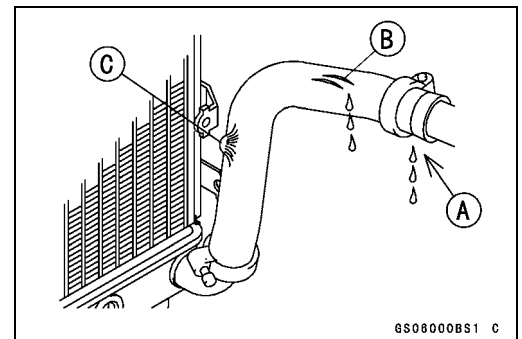

Coolant Change

⚠ WARNING

To avoid burns, do not remove the radiator cap or try to change the coolant when the engine is still hot. Wait until it cools down. Coolant on tires will make them slippery and can cause an accident and injury. Immediately wipe up or wash away any coolant that spills on the frame, engine, or other painted parts. Since coolant is harmful to the human body, do not use for drinking.

2-16 PERIODIC MAINTENANCE

Periodic Maintenance Procedures

- Remove:
 - Right Lower Inner Cover (see Frame chapter)
 - Right Air Inlet Duct (see Fuel System (DFI) chapter)
 - Radiator Cap [A]
- Remove the radiator cap in two steps. First turn the cap counterclockwise to the first stop. Then push and turn it further in the same direction and remove the cap.

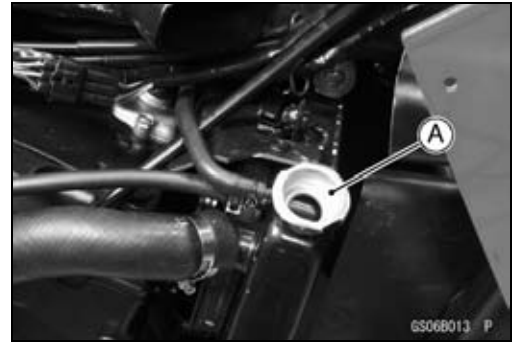

- Remove:
 - Left Lower Fairing (see Frame chapter)
- Place a containers under the drain plugs [A] and [B] at the bottom of the water pump cover and cylinder.
- Drain the coolant from the radiator and engine by removing the drain plugs.

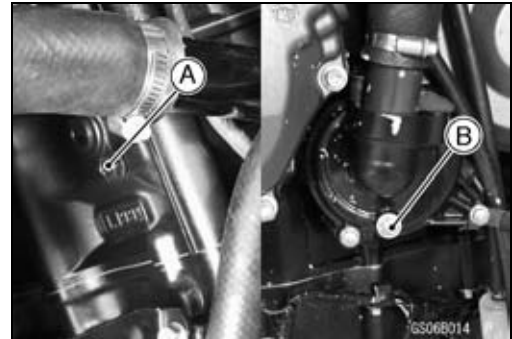

- Remove:
 - Mounting Screws [A] and Reserve Tank [B]
 - Hose [C]
- Remove the cap [D] and pour the coolant into a container.

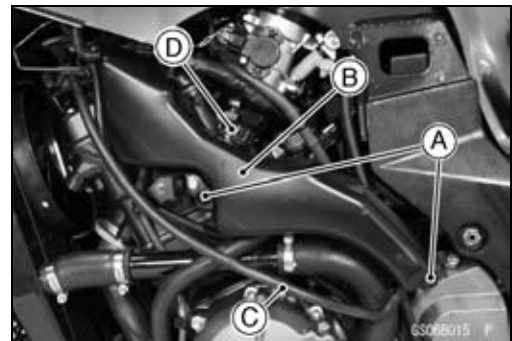

- Install the reserve tank.
- Tighten the drain plugs with the washers.
- Replace the drain plug gasket with new one if it is damaged.

Torque - Coolant Drain Plug (Water Pump): 12 N·m (1.2 kgf·m, 106 in·lb)

Coolant Drain Plug (Cylinder): 10 N·m (1.0 kgf·m, 89 in·lb)

- Fill the radiator up to the radiator filler neck [A] with coolant, and install the radiator cap.

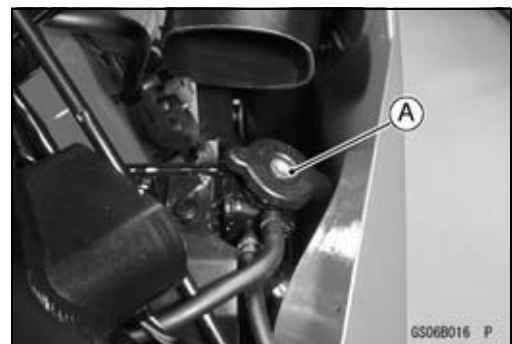

NOTE

○ Pour in the coolant slowly so that it can expel the air from the engine and radiator.

- Fill the reserve tank up to the full level line with coolant, and install the cap.

CAUTION

Soft or distilled water must be used with the antifreeze (see below for antifreeze) in the cooling system.

If hard water is used in the system, it causes scales accumulation in the water passages, and considerably reduces the efficiency of the cooling system.

Periodic Maintenance Procedures

Water and Coolant Mixture Ratio (Recommended)

- Soft Water: 50%
- Coolant: 50%
- Freezing Point: – 35°C (– 31°F)
- Total Amount: 3.6 L (3.8 US qt)

NOTE

○Choose a suitable mixture ratio by referring to the coolant manufacturer's directions.

- Bleed the air from the cooling system as follows.
 - Start the engine with the radiator cap removed and run it until no more air bubbles [A] can be seen in the coolant.
 - Tap the radiator hoses to force any air bubbles caught inside.
 - Stop the engine and add coolant up to the radiator filler neck.
- Install the radiator cap.
- Start the engine, warm it up thoroughly until the radiator fan turns on and then stop the engine.
- Check the coolant level in the reserve tank after the engine cools down.
- ★ If the coolant level is lower than the low level line, add coolant to the full level line.

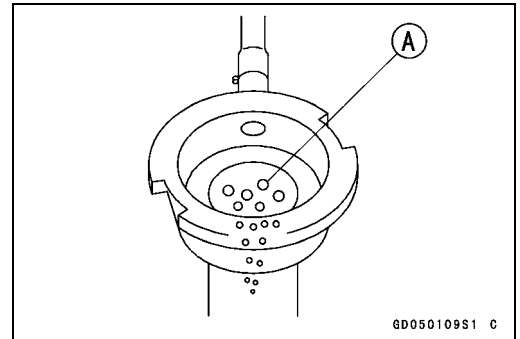

CAUTION

Do not add more coolant above the full level line.

Engine Top End

Air Suction Valve Inspection

- Remove the air suction valve (see Air Suction Valve Removal section in Engine Top End chapter).
 - ZX1200-B1/B2 [A]
 - ZX1200-B3 [B]
- Visually inspect the reeds [C] for cracks, folds, warps, heat damage, or other damage.
 - ★ If there is any doubt as to the condition of the reed, replace the air suction valve as an assembly.
- Check the reed contact areas [D] of the valve holder for grooves, scratches, any signs of separation from the holder, or heat damage.
 - ★ If there is any doubt as to the condition of the reed contact areas, replace the air suction valve as an assembly.
 - ★ If any carbon or other foreign particles have accumulated between the reed and the reed contact area, wash the valve assembly with a high flash-point solvent.

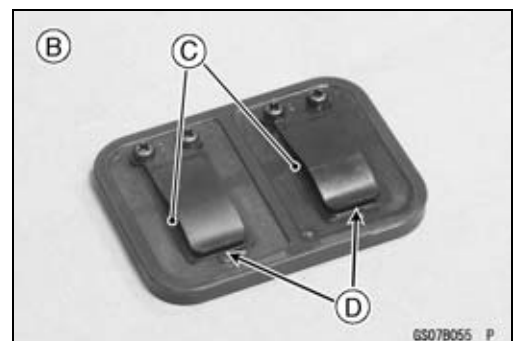
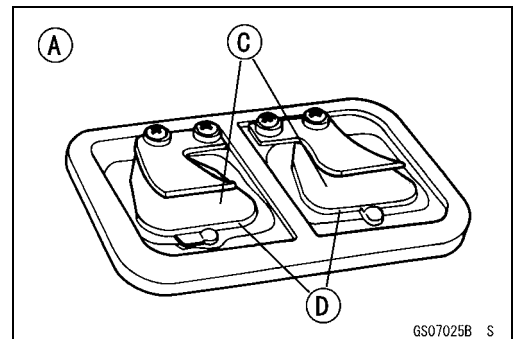

CAUTION

Do not scrape off the deposits with a scraper as this could damage the rubber, requiring replacement of the suction valve assembly.

2-18 PERIODIC MAINTENANCE

Periodic Maintenance Procedures

Valve Clearance Inspection

NOTE

○ Valve clearance must be checked and adjusted when the engine is cold (at room temperature).

- Remove:
 - Lower Fairings with Lower Inner Fairing (see Frame chapter)
 - Crankshaft Sensor Cover (see Electrical System chapter)
 - Cylinder Head Cover (see Cylinder Head Cover Removal section in Engine Top End chapter)
- Position the crankshaft at #1, #4 piston TDC.
 - TDC Mark [A] for #1, #4 Pistons
 - Timing Mark [B] (crankcase halves mating surface)

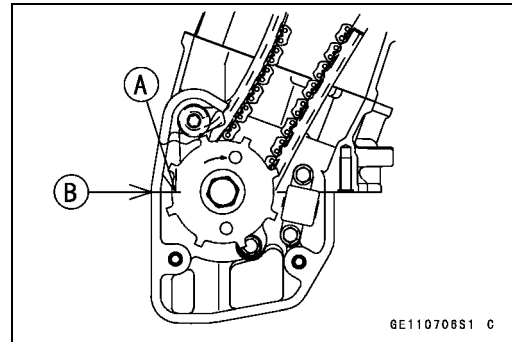

- ★ If just after the camshaft cap is installed, rotate the crankshaft two turns in the right direction.
- Measure the valve clearance between the cam and the valve lifter with a thickness gauge [A].

Valve Clearance

Standard:

Exhaust	0.22 ~ 0.31 mm (0.0087 ~ 0.0122 in.)
Inlet	0.15 ~ 0.24 mm (0.0059 ~ 0.0094 in.)



- When positioning #4 piston TDC at the end of the compression stroke:

Inlet valve clearance of #2 and #4 cylinders
 Exhaust valve clearance of #3 and #4 cylinders

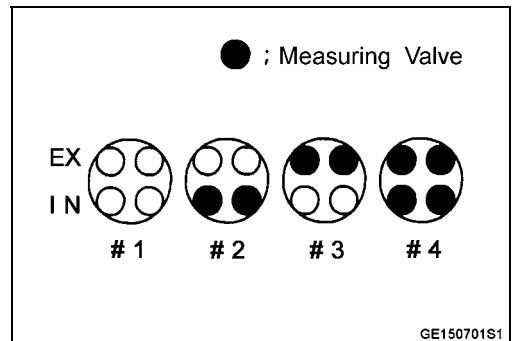

- When positioning #1 piston TDC at the end of the compression stroke:

Inlet valve clearance of #1 and #3 cylinders
 Exhaust valve clearance of #1 and #2 cylinders

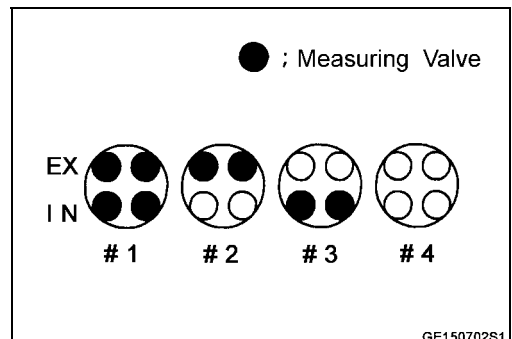

- ★ If the valve clearance is not within the specified range, first record the clearance, and then adjust it.

Periodic Maintenance Procedures

- To change the valve clearance, remove the camshaft chain tensioner, camshafts and valve lifters. Replace the shim with one of a different thickness.

NOTE

- *Mark and record the valve lifter and shim locations so they can be reinstalled in their original positions.*
- *If there is no clearance, select a shim which is several sizes smaller and then measure the clearance.*
- To select a new shim which brings the valve clearance within the specified range, refer to the Valve Clearance Adjustment Charts.
- Apply molybdenum disulfide oil to the valve lifters and apply engine oil to the shims.
- Install the camshafts. Be sure to time the camshafts properly (see Camshaft Installation).
- Remeasure any valve clearance that was adjusted. Readjust if necessary.

CAUTION
<p>Do not put shim stock under the shim. This may cause the shim to pop out at high rpm, causing extensive engine damage.</p> <p>Do not grind the shim. This may cause it to fracture, causing extensive engine damage.</p>

2-20 PERIODIC MAINTENANCE

Periodic Maintenance Procedures

INLET VALVE CLEARANCE ADJUSTMENT CHART

	Present Shim																			Example		
Part No. (92025)	1870	1871	1872	1873	1874	1875	1876	1877	1878	1879	1880	1881	1882	1883	1884	1885	1886	1887	1888	1889	1890	
Mark	0	5	10	15	20	25	30	35	40	45	50	55	60	65	70	75	80	85	90	95	00	
Thickness (mm)	2.00	2.05	2.10	2.15	2.20	2.25	2.30	2.35	2.40	2.45	2.50	2.55	2.60	2.65	2.70	2.75	2.80	2.85	2.90	2.95	3.00	

Valve Clearance Measurement (mm)	Specified Clearance / No Change Required																				
	0.00 ~ 0.02	—	—	—	—	2.00	2.05	2.10	2.15	2.20	2.25	2.30	2.35	2.40	2.45	2.50	2.55	2.60	2.65	2.70	2.75
0.03 ~ 0.06	—	—	—	2.00	2.05	2.10	2.15	2.20	2.25	2.30	2.35	2.40	2.45	2.50	2.55	2.60	2.65	2.70	2.75	2.80	2.85
0.07 ~ 0.11	—	—	2.00	2.05	2.10	2.15	2.20	2.25	2.30	2.35	2.40	2.45	2.50	2.55	2.60	2.65	2.70	2.75	2.80	2.85	2.90
0.12 ~ 0.14	—	2.00	2.05	2.10	2.15	2.20	2.25	2.30	2.35	2.40	2.45	2.50	2.55	2.60	2.65	2.70	2.75	2.80	2.85	2.90	2.95
0.15 ~ 0.24	Specified Clearance / No Change Required																				
0.25 ~ 0.27	2.05	2.10	2.15	2.20	2.25	2.30	2.35	2.40	2.45	2.50	2.55	2.60	2.65	2.70	2.75	2.80	2.85	2.90	2.95	3.00	
0.28 ~ 0.32	2.10	2.15	2.20	2.25	2.30	2.35	2.40	2.45	2.50	2.55	2.60	2.65	2.70	2.75	2.80	2.85	2.90	2.95	3.00		
0.33 ~ 0.37	2.15	2.20	2.25	2.30	2.35	2.40	2.45	2.50	2.55	2.60	2.65	2.70	2.75	2.80	2.85	2.90	2.95	3.00			
0.38 ~ 0.42	2.20	2.25	2.30	2.35	2.40	2.45	2.50	2.55	2.60	2.65	2.70	2.75	2.80	2.85	2.90	2.95	3.00				
0.43 ~ 0.47	2.25	2.30	2.35	2.40	2.45	2.50	2.55	2.60	2.65	2.70	2.75	2.80	2.85	2.90	2.95	3.00					
0.48 ~ 0.52	2.30	2.35	2.40	2.45	2.50	2.55	2.60	2.65	2.70	2.75	2.80	2.85	2.90	2.95	3.00						
0.53 ~ 0.57	2.35	2.40	2.45	2.50	2.55	2.60	2.65	2.70	2.75	2.80	2.85	2.90	2.95	3.00							
0.58 ~ 0.62	2.40	2.45	2.50	2.55	2.60	2.65	2.70	2.75	2.80	2.85	2.90	2.95	3.00								
0.63 ~ 0.67	2.45	2.50	2.55	2.60	2.65	2.70	2.75	2.80	2.85	2.90	2.95	3.00									
0.68 ~ 0.72	2.50	2.55	2.60	2.65	2.70	2.75	2.80	2.85	2.90	2.95	3.00										
0.73 ~ 0.77	2.55	2.60	2.65	2.70	2.75	2.80	2.85	2.90	2.95	3.00											
0.78 ~ 0.82	2.60	2.65	2.70	2.75	2.80	2.85	2.90	2.95	3.00												
0.83 ~ 0.87	2.65	2.70	2.75	2.80	2.85	2.90	2.95	3.00													
0.88 ~ 0.92	2.70	2.75	2.80	2.85	2.90	2.95	3.00														
0.93 ~ 0.97	2.75	2.80	2.85	2.90	2.95	3.00															
0.98 ~ 1.02	2.80	2.85	2.90	2.95	3.00																
1.03 ~ 1.07	2.85	2.90	2.95	3.00																	
1.08 ~ 1.12	2.90	2.95	3.00																		
1.13 ~ 1.17	2.95	3.00																			
1.18 ~ 1.22	3.00																				

Install the shim of this thickness (mm).

1. Measure the clearance (when engine is cold).
2. Check present shim size.
3. Match clearance in vertical column with present shim size in horizontal column.
4. Install the shim specified where the lines intersect. This shim will give the proper clearance.

Example:

Present shim is **2.60 mm**.

Measured clearance is **0.35 mm**.

Replace **2.60 mm** shim with **2.75 mm** shim.

5. Remeasure the valve clearance and readjust if necessary.

Periodic Maintenance Procedures

EXHAUST VALVE CLEARANCE ADJUSTMENT CHART

Part No. (92025)	Present Shim																				
	1870	1871	1872	1873	1874	1875	1876	1877	1878	1879	1880	1881	1882	1883	1884	1885	1886	1887	1888	1889	1890
Mark	0	5	10	15	20	25	30	35	40	45	50	55	60	65	70	75	80	85	90	95	00
Thickness (mm)	2.00	2.05	2.10	2.15	2.20	2.25	2.30	2.35	2.40	2.45	2.50	2.55	2.60	2.65	2.70	2.75	2.80	2.85	2.90	2.95	3.00

Valve Clearance Measurement (mm)	Present Shim																				
	1870	1871	1872	1873	1874	1875	1876	1877	1878	1879	1880	1881	1882	1883	1884	1885	1886	1887	1888	1889	1890
0.00 ~ 0.04	—	—	—	—	—	2.00	2.05	2.10	2.15	2.20	2.25	2.30	2.35	2.40	2.45	2.50	2.55	2.60	2.65	2.70	2.75
0.05 ~ 0.09	—	—	—	—	2.00	2.05	2.10	2.15	2.20	2.25	2.30	2.35	2.40	2.45	2.50	2.55	2.60	2.65	2.70	2.75	2.80
0.10 ~ 0.14	—	—	—	2.00	2.05	2.10	2.15	2.20	2.25	2.30	2.35	2.40	2.45	2.50	2.55	2.60	2.65	2.70	2.75	2.80	2.85
0.15 ~ 0.19	—	—	2.00	2.05	2.10	2.15	2.20	2.25	2.30	2.35	2.40	2.45	2.50	2.55	2.60	2.65	2.70	2.75	2.80	2.85	2.90
0.20 ~ 0.21	—	2.00	2.05	2.10	2.15	2.20	2.25	2.30	2.35	2.40	2.45	2.50	2.55	2.60	2.65	2.70	2.75	2.80	2.85	2.90	2.95
0.22 ~ 0.31	Specified Clearance / No Change Required																				
0.32 ~ 0.34	2.05	2.10	2.15	2.20	2.25	2.30	2.35	2.40	2.45	2.50	2.55	2.60	2.65	2.70	2.75	2.80	2.85	2.90	2.95	3.00	
0.35 ~ 0.39	2.10	2.15	2.20	2.25	2.30	2.35	2.40	2.45	2.50	2.55	2.60	2.65	2.70	2.75	2.80	2.85	2.90	2.95	3.00		
0.40 ~ 0.44	2.15	2.20	2.25	2.30	2.35	2.40	2.45	2.50	2.55	2.60	2.65	2.70	2.75	2.80	2.85	2.90	2.95	3.00			
0.45 ~ 0.49	2.20	2.25	2.30	2.35	2.40	2.45	2.50	2.55	2.60	2.65	2.70	2.75	2.80	2.85	2.90	2.95	3.00				
0.50 ~ 0.54	2.25	2.30	2.35	2.40	2.45	2.50	2.55	2.60	2.65	2.70	2.75	2.80	2.85	2.90	2.95	3.00					
0.55 ~ 0.59	2.30	2.35	2.40	2.45	2.50	2.55	2.60	2.65	2.70	2.75	2.80	2.85	2.90	2.95	3.00						
0.60 ~ 0.64	2.35	2.40	2.45	2.50	2.55	2.60	2.65	2.70	2.75	2.80	2.85	2.90	2.95	3.00							
0.65 ~ 0.69	2.40	2.45	2.50	2.55	2.60	2.65	2.70	2.75	2.80	2.85	2.90	2.95	3.00								
0.70 ~ 0.74	2.45	2.50	2.55	2.60	2.65	2.70	2.75	2.80	2.85	2.90	2.95	3.00									
0.75 ~ 0.79	2.50	2.55	2.60	2.65	2.70	2.75	2.80	2.85	2.90	2.95	3.00										
0.80 ~ 0.84	2.55	2.60	2.65	2.70	2.75	2.80	2.85	2.90	2.95	3.00											
0.85 ~ 0.89	2.60	2.65	2.70	2.75	2.80	2.85	2.90	2.95	3.00												
0.90 ~ 0.94	2.65	2.70	2.75	2.80	2.85	2.90	2.95	3.00													
0.95 ~ 0.99	2.70	2.75	2.80	2.85	2.90	2.95	3.00														
1.00 ~ 1.04	2.75	2.80	2.85	2.90	2.95	3.00															
1.05 ~ 1.09	2.80	2.85	2.90	2.95	3.00																
1.10 ~ 1.14	2.85	2.90	2.95	3.00																	
1.15 ~ 1.19	2.90	2.95	3.00																		
1.20 ~ 1.24	2.95	3.00																			
1.25 ~ 1.29	3.00																				

Install the shim of this thickness (mm).

1. Measure the clearance (when engine is cold).
2. Check present shim size.
3. Match clearance in vertical column with present shim size in horizontal column.
4. Install the shim specified where the lines intersect. This shim will give the proper clearance.

Example:

Present shim is **2.65 mm**.
 Measured clearance is **0.42 mm**.
 Replace **2.65 mm** shim with **2.80 mm** shim.

5. Remeasure the valve clearance and readjust if necessary.

2-22 PERIODIC MAINTENANCE

Periodic Maintenance Procedures

Clutch

Clutch Adjust Inspection

- Pull the clutch lever just enough to take up the free play [A].
- Measure the gap between the lever and the lever holder.
- ★ If the gap is too wide, the clutch may not release fully. If the gap is too narrow, the clutch may not engage fully. In either case, adjust it.

Clutch Lever Free Play

Standard: 2 ~ 3 mm (0.08 ~ 0.12 in.)



⚠ WARNING

To avoid a serious burn, never touch the engine or muffler during clutch adjustment.

- Turn the adjuster [A] so that 5 ~ 6 mm (0.20 ~ 0.24 in.) [B] of threads are visible.

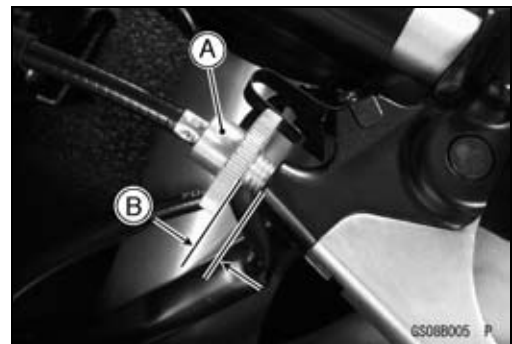

- Slide the dust cover [A] at the clutch cable lower end out of place.
- Loosen both adjusting nuts [B] at the clutch cover as far as they will go.
- Pull the clutch outer cable [C] tight and tighten the adjusting nuts against the bracket [D].
- Slip the rubber dust cover back onto place.
- Turn the adjuster at the clutch lever until the free play is correct.

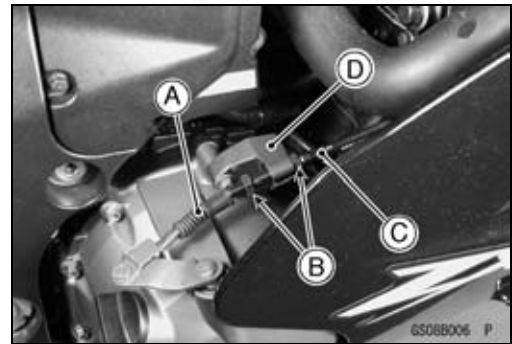

- Push the release lever [A] toward the front of the motorcycle until it becomes hard to turn.
- At this time, the release lever should have the proper angle shown.
- ★ If the angle is wrong, check the clutch and release parts for wear.

⚠ WARNING

Be sure that the outer cable end at the clutch lever is fully seated in the adjuster at the clutch lever, or it could slip into place later, creating enough cable play to prevent clutch disengagement.

- After the adjustment, start the engine and check that the clutch does not slip and that it releases properly.

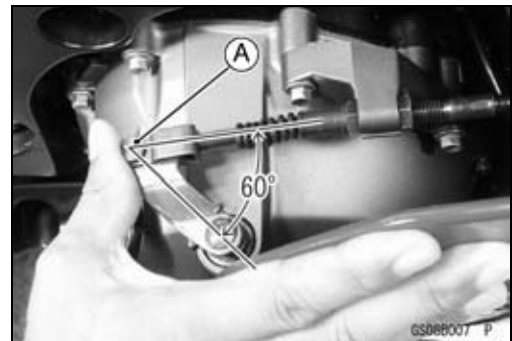

Periodic Maintenance Procedures

Engine Lubrication System

Engine Oil Change

- Support the motorcycle perpendicular to the ground after warming up the engine.
- Remove the engine oil drain plug [A] to drain the oil.
- The oil in the oil filter can be drained by removing the filter (see Oil Filter Change).
- Replace the drain plug gasket with a new one if it is damaged.
- Tighten the drain plug.
- Torque - Engine Oil Drain Plug: 20 N·m (2.0 kgf·m, 15 ft·lb)**
- Pour in the specified type and amount of oil.

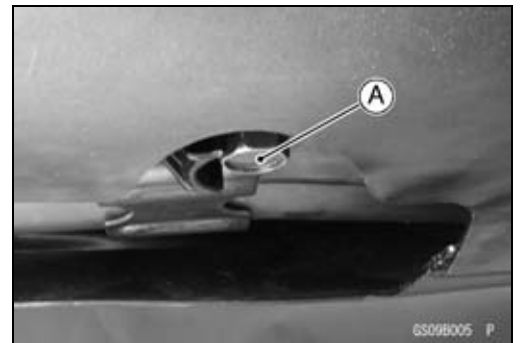

Engine Oil

- Grade:** API SE, SF or SG
API SH or SJ with JASO MA
- Viscosity:** SAE 10W-40
- Amount:** 2.5 L (2.6 US qt, when filter is not removed)
2.8 L (3.0 US qt, when filter is removed)
3.6 L (3.8 US qt, when engine is completely dry)

NOTE

○ Although 10W-40 engine oil is the recommended oil for most conditions, the oil viscosity may need to be changed to accommodate atmospheric conditions in your riding area.

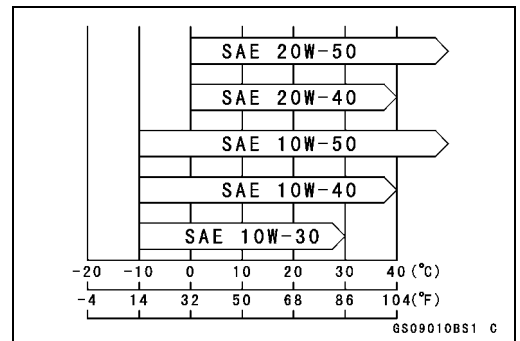

Oil Filter Replace

- Drain the engine oil (see Engine Oil Change).
- Remove:
 - Lower Inner Fairing (see Frame chapter)
- Remove the oil filter [B] with the oil filter wrench [A].
- Special Tool - Oil Filter Wrench: 57001-1249**

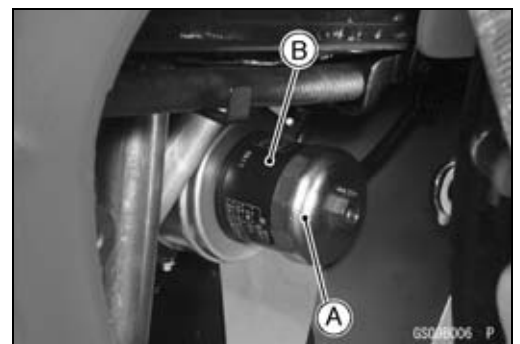

- Replace the filter with a new one.
- Apply engine oil to the gasket [A] before installation.
- Tighten the filter with the oil filter wrench.
- Torque - Oil Filter: 31 N·m (3.2 kgf·m, 23 ft·lb)**
- Pour in the specified type and amount of oil (see Engine Oil Change).

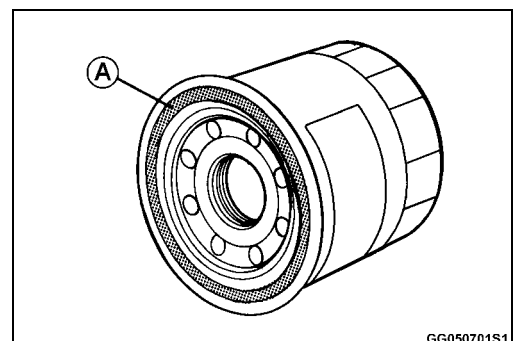

2-24 PERIODIC MAINTENANCE

Periodic Maintenance Procedures

Wheels/Tires

Tire Wear Inspection

As the tire tread wears down, the tire becomes more susceptible to puncture and failure. An accepted estimate is that 90% of all tire failures occur during the last 10% of tread life (90% worn). So it is false economy and unsafe to use the tires until they are bald.

- Remove any imbedded stones or other foreign particles from the tread.
 - Visually inspect the tire for cracks and cuts, replacing the tire in case of damage. Swelling or high spots indicate internal damage, requiring tire replacement.
 - Measure the tread depth at the center of the tread with a depth gage [A]. Since the tire may wear unevenly, take measurement at several places.
- ★ If any measurement is less than the service limit, replace the tire.

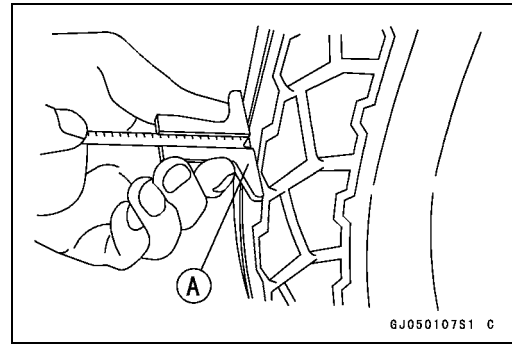

Tread Depth

Front:

- Standard:** 4.0 mm (0.16 in.) (DUNLOP)
Service Limit: 1 mm (0.04 in.)
(AT, CH, DE) 1.6 mm (0.06 in.)

Rear:

- Standard:** 5.4 mm (0.21 in.) (DUNLOP)
Service Limit: 2 mm (0.08 in.)
(Up to 130 km/h, 80 mph)
3 mm (0.12 in.)
(Over 130 km/h, 80 mph)

⚠ WARNING

To ensure safe handling and stability, use only the recommended standard tires for replacement, inflated to the standard pressure. Use the same manufacturer's tires on both front and rear wheels.

NOTE

- Most countries may have their own regulations a minimum tire tread depth: be sure to follow them.
- Check and balance the wheel when a tire is replaced with a new one.

Periodic Maintenance Procedures

Final Drive

Drive Chain Slack Inspection

NOTE

- Check the slack with the motorcycle setting on its side stand.
- Clean the chain if it is dirty, and lubricate it if it appears dry.
- Check the wheel alignment.
- Rotate the rear wheel to find the position where the chain is tightest.
- Measure the vertical movement (chain slack) [A] midway between the sprockets.
- ★ If the chain slack exceeds the standard, adjust it.

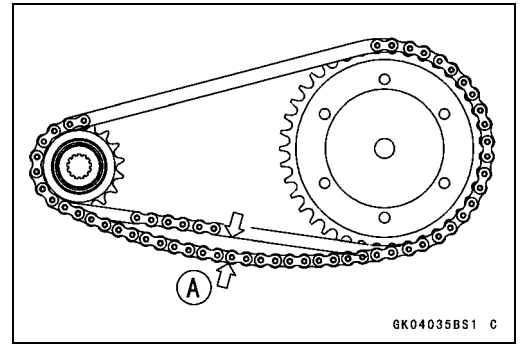

Chain Slack

Standard: 25 ~ 35 mm (0.98 ~ 1.4 in.)

- Remove the cotter pin [A], and loosen the axle nut [B].
- Loosen the both chain adjuster locknuts [C].
- Turn the chain adjusters [D] forward or rearward until the drive chain has the correct amount of chain slack.
- The right and left notches [E] on the alignment indicators [F] should point to the same marks or positions [G] on the swingarm.

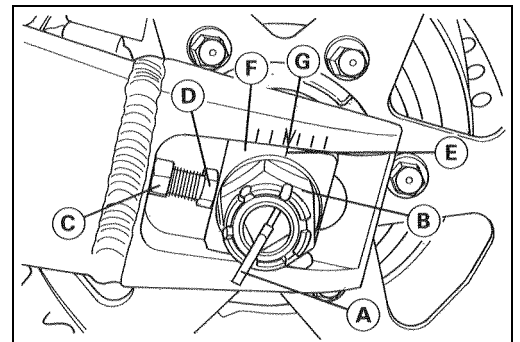

⚠ WARNING

Misalignment of the wheel will result in abnormal wear and may result in an unsafe riding condition.

- Tighten both chain adjuster locknuts securely.
- Tighten the axle nut.
- Torque - Rear Axle Nut: 125 N·m (13 kgf·m, 92 ft·lb)**
- Turn the wheel, measure the chain slack again at the tightest position, and readjust if necessary.
- Insert a new cotter pin [A].

NOTE

- When inserting the cotter pin, if the slots in the nut do not align with the cotter pin hole in the axle, tighten the nut clockwise [B] up to next alignment.
- It should be within 30 degree.
- Loosen once and tighten again when the slot goes past the nearest hole.

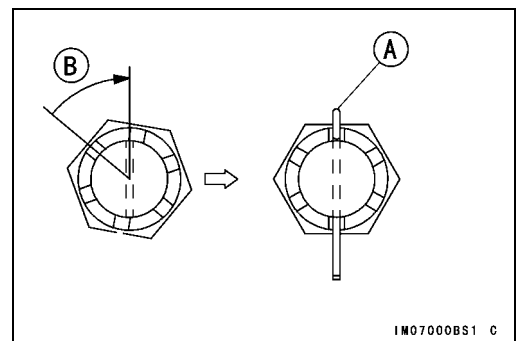

2-26 PERIODIC MAINTENANCE

Periodic Maintenance Procedures

- Bend the cotter pin [A] over the nut [B].

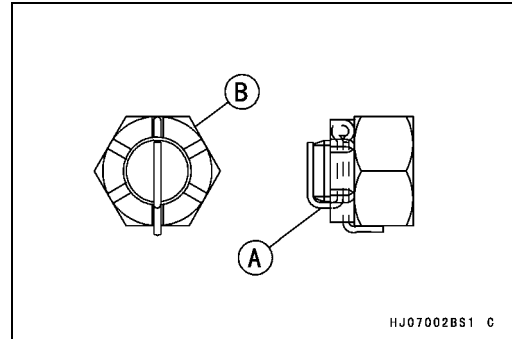

- Check that the right and left notches [A] on the alignment indicators [B] point to the same marks or positions [C] on the swingarm.
- ★ If they are not, adjust the chain slack and align the wheel alignment.

NOTE

○ Wheel alignment can be also be checked using the straightedge or string method.

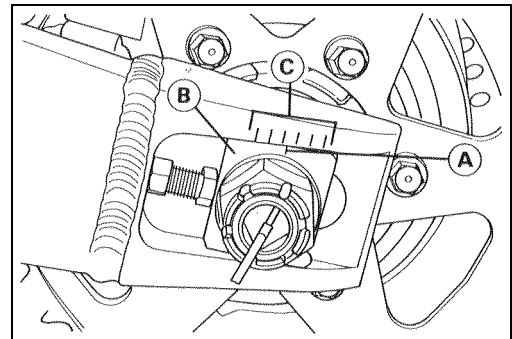

⚠ WARNING

Misalignment of the wheel will result in abnormal wear, and may result in an unsafe riding condition.

Drive Chain Wear Inspection

- Remove:
 - Mounting Screws [A]
 - Chain Cover [B]

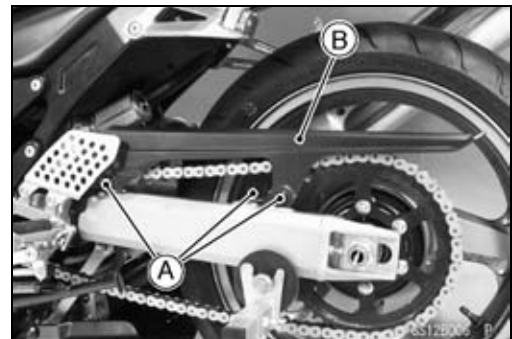

Periodic Maintenance Procedures

- Rotate the rear wheel to inspect the drive chain for cracked, worn or damaged rollers [B], pins [F] and links [E, C]
- ★ If there is any irregularity, replace the drive chain

Drive Chain Roller Wear

- Measure the distance [A] between the rollers [B] in the inner link plates [C] with Vernier calipers to inspect wear between the roller and bushing. Since the roller and bushing may wear unqually, take measurements at six places.

NOTE

○ Do not measure the distance [G] between the rollers [D] in the outer link plates [E] to inspect wear between the bushing and pin [F].

- ★ If any measurements exceed the service limit, replace the chain. Also, replace the front and rear sprockets when the drive chain is replaced.

Rollers Distance

- Standard:** Less than 6 mm (0.236 in.)
- Service Limit:** 6.2 mm (0.244 in.)

Drive Chain Wear

- Stretch the chain taut by hanging a 98 N (10 kg, 20 lb) weight [A] on the chain
- Measure the length of 20 links [B] on the straight part [C] of the chain from the pin center of the 1st pin to the pin center of the 21st pin. Since the chain may wear unevenly, take measurements at several places.
- ★ If any measurements exceed the service limit, replace the chain. Also, replace the front and rear sprockets when the drive chain is replaced.

Drive Chain 20-link Length

- Standard:** 317.5 ~ 318.2 mm (12.50 ~ 12.53 in.)
- Service Limit:** 323 mm (12.7 in.)

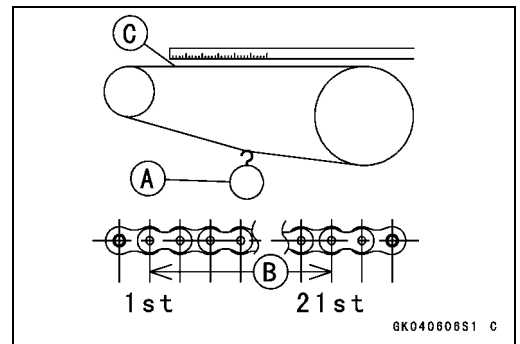
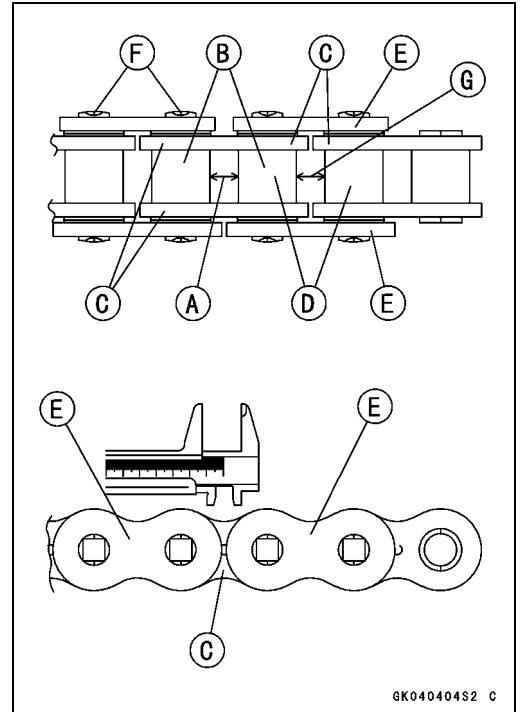

⚠ WARNING

If the drive chain wear exceeds the service limit, replace the chain or an unsafe riding condition may result. A chain that breaks or jumps off the sprockets could snag on the engine sprocket or lock the rear wheel, severely damaging the motorcycle and causing it to go out of control.

For safety, use only the standard chain. It is an endless type and should not be cut for installation.

2-28 PERIODIC MAINTENANCE

Periodic Maintenance Procedures

Drive Chain Lubrication

- If a special lubricant is not available, a heavy oil such as SAE 90 is preferred to lighter oil because it will stay on the chain longer and provide better lubrication.
- If the chain appears especially dirty, clean it before lubrication.
 - Oil Applied Grease [A]
 - O-rings [B]

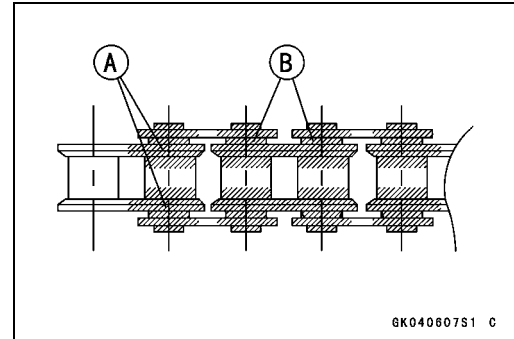

CAUTION

The O-rings between the side plates seal the lubricant between the pin and the bushing. To avoid damaging the O-rings and resultant loss of lubricant, observe the following rules.

Use only kerosene or diesel oil for cleaning an O-ring drive chain.

Any other cleaning solution such as gasoline or trichloroethylene will cause deterioration and swelling of the O-ring.

Immediately blow the chain dry with compressed air after cleaning.

Complete cleaning and drying the chain within 10 minutes.

- Apply oil to the sides of the rollers so that oil will penetrate to the rollers and bushings. Apply oil to the O-rings so that the O-rings will be coated with oil.
- Wipe off any excess oil.

Brakes

Brake Hose, Connection Inspection

- Inspect the brake hose and fitting for deterioration, cracks and signs of leakage.
- The high pressure inside the brake line can cause fluid to leak [A] or the hose to burst if the line is not properly maintained. Bend and twist the rubber hose while examining it.
- ★ Replace it if any cracks [B], bulges [C] or fluid leak are noticed.
- ★ Tighten any loose fittings.

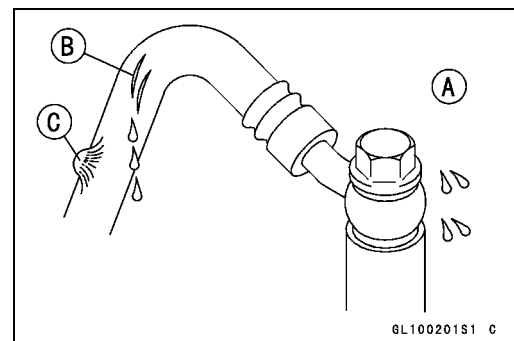

Periodic Maintenance Procedures

Brake Fluid Level Inspection

- Check that the brake fluid level in the front brake reservoir [A] is above the lower level line [B].

NOTE

○ Hold the reservoir horizontal by turning the handlebar when checking brake fluid level.

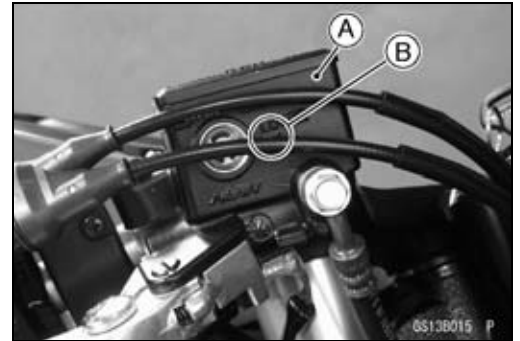

- ★ If the fluid level is lower than the lower level line, fill the reservoir to the upper level line [A] in the reservoir [B].



- Check that the brake fluid level in the rear brake reservoir [A] is between the upper [B] and the lower [C] level lines.
- ★ If the fluid level is lower than the lower level line, remove the seats and fill the reservoir to the upper level line.

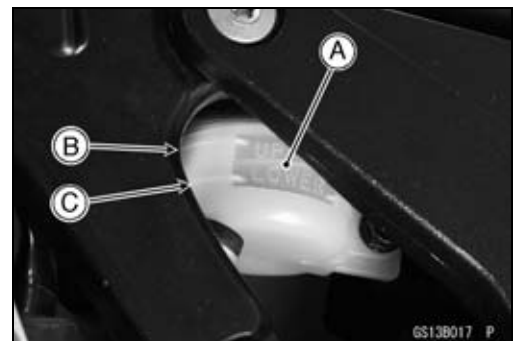

⚠ WARNING

Change the brake fluid in the brake line completely if the brake fluid must be refilled but the type and brand of the brake fluid that is already in the reservoir are unidentified. After changing the fluid, use only the same type and brand of fluid thereafter.

Recommended Disc Brake Fluid
Grade: DOT4

Brake Fluid Change

NOTE

○ The procedure to change the front brake fluid is as follows. Changing the rear brake fluid is the same as for the front brake.

- Level the brake fluid reservoir.
- Remove the reservoir cap and diaphragm.
- Remove the rubber cap from the bleed valve [A] on the caliper.
- Attach a clear plastic hose [B] to the bleed valve, and run the other end of the hose into a container.
- Fill the reservoir with fresh specified brake fluid.

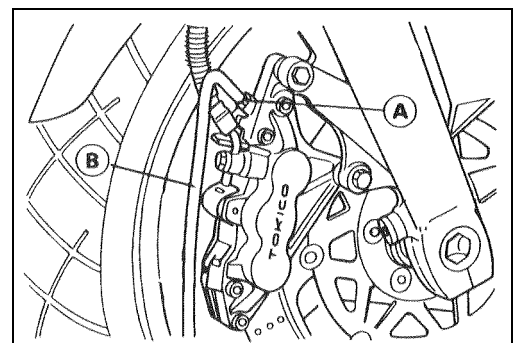

2-30 PERIODIC MAINTENANCE

Periodic Maintenance Procedures

- Change the brake fluid as follows:
- Repeat this operation until fresh brake fluid comes out from the plastic hose or the color of the fluid changes.
- 1. Open the bleed valve [C].
- 2. Apply the brake and hold it [B].
- 3. Close the bleed valve [A].
- 4. Release the brake [D].

NOTE

- The fluid level must be checked often during the changing operation and replenished with fresh brake fluid. If the fluid in the reservoir runs out any time during the changing operation, the brakes will need to be bled since air will have entered the brake line.
 - Front brake: Repeat the above steps for the other caliper.
 - Rear brake: Repeat the above steps for the other bleed valve.
- Remove the clear plastic hose.
 - Install the reservoir cap.
 - Tighten the front reservoir cap screws.

Torque - Front Reservoir Cap Screws: 1.5 N·m (0.15 kgf·m, 13 in·lb)

- Tighten the bleed valve, and install the rubber cap.

Torque - Bleed Valve: 7.8 N·m (0.80 kgf·m, 69 in·lb)

- After changing the fluid, check the brake for good braking power, no brake drag, and no fluid leakage.
- ★ If necessary, bleed the air from the lines.

Front Brake Pad Wear Inspection

- Remove the brake pads (see Brakes chapter).
- Check the lining thickness [A] of the pads in each caliper.
- ★ If the lining thickness of either pad is less than the service limit [B], replace both pads in the caliper as a set (see Brakes chapter).

Pad Lining Thickness

Standard: 4 mm (0.12 in.)

Service Limit: 1 mm (0.04 in.)

ZX1200-B3 [C]

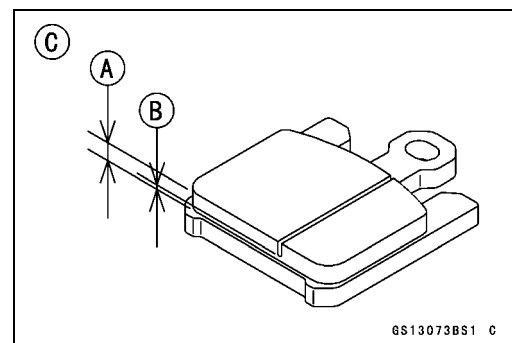
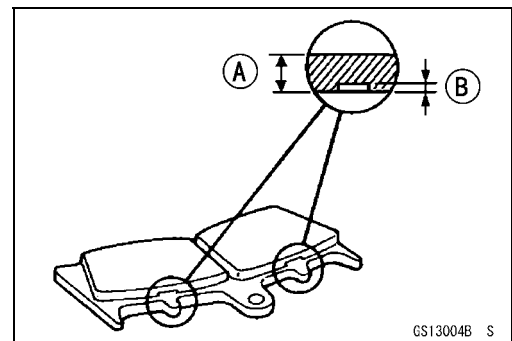
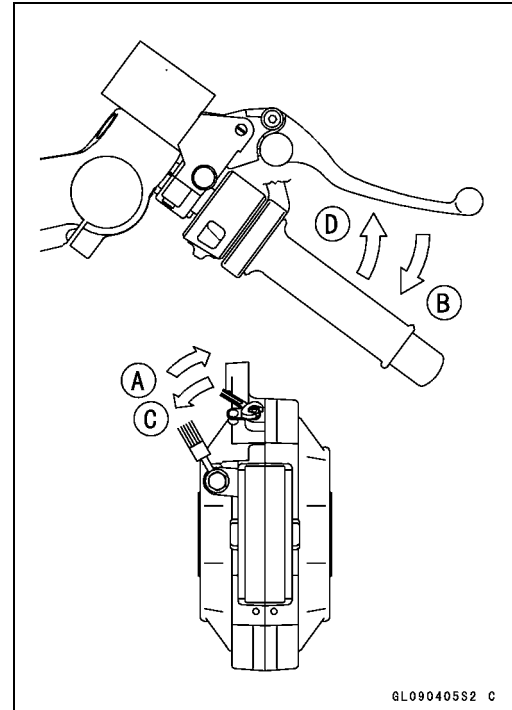

Periodic Maintenance Procedures

Rear Brake Pad Wear Inspection

- Remove the brake pads (see Brakes chapter).
- Check the lining thickness [A] of the pads in each caliper.
- ★ If the lining thickness of either pad is less than the service limit [B], replace both pads in the caliper as a set (see Brakes chapter).

Pad Lining Thickness

Standard: 4 mm (0.12 in.)

Service Limit: 1 mm (0.04 in.)

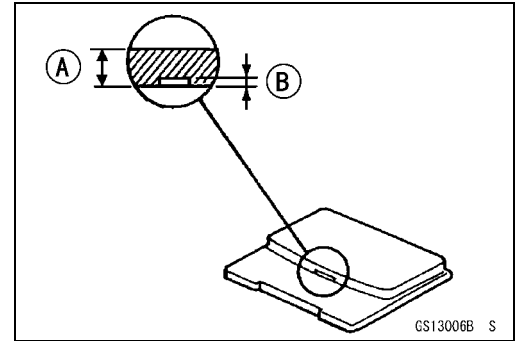

Brake/Master Cylinder Cup and Dust Seal Replace

- Refer to the Master Cylinder section in the Brakes chapter for Brake/Master Cylinder Cup and Dust Seal Replacement.

Caliper Piston/Dust Seal Replace

- Refer to the Calipers section in the Brakes chapter for Caliper Piston/Dust Seals Replacement.

Front Brake Light Switch Inspection

- Turn on the ignition switch.
- The brake light should go on when the front brake lever is applied.
- ★ If it does not, replace the switch.

Rear Brake Light Switch Inspection/Adjustment

- Turn on the ignition switch.
- Check the operation of the rear brake light switch by depressing the brake pedal.
- ★ If it does not as specified, adjust the brake light timing.

Brake Light Timing

Standard: On after about 10 mm (0.39 in.) of pedal travel [A]

- While holding the switch body, turn the adjusting nut [A] to adjust the switch.



CAUTION

To avoid damaging the electrical connections inside the switch, be sure that the switch body does not turn during adjustment.

2-32 PERIODIC MAINTENANCE

Periodic Maintenance Procedures

Suspension

Front Fork Oil Change

ZX1200-B1/B2

- Remove the front fork (see Front Fork Removal in Suspension chapter).
- Turn the spring preload adjuster [A] counterclockwise until the fully position.
- Turn the rebound damping adjuster [C] clockwise until the fully tightened position.
- Unscrew the top plug [B] out of the inner tube.

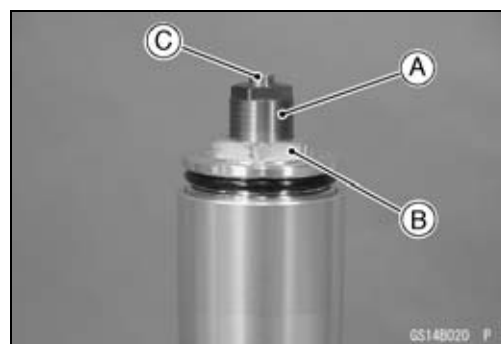

- Hold the bottom of the front fork with a vice.



- How to remove the top plug from the push rod with the front fork spring compressor set is as follows.

Special Tool - Fork Spring Compressor Set: 57001-1452

- Set the front fork holder [A] on the spacer [B] top end along with the stopper [C].

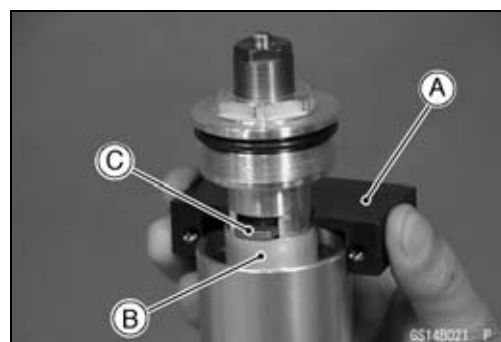

- Tighten the bolts [B] to hold the outer tube by using the front fork holder [A], and install the rod [C] to the holder.



- Install the two collars [A] to the brake caliper mounting holes of the front fork bracket.

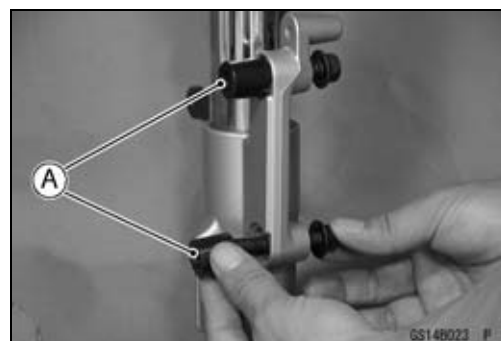

Periodic Maintenance Procedures

○Install the holder plate [A] and lever [B] on these collars with the bolt [C].

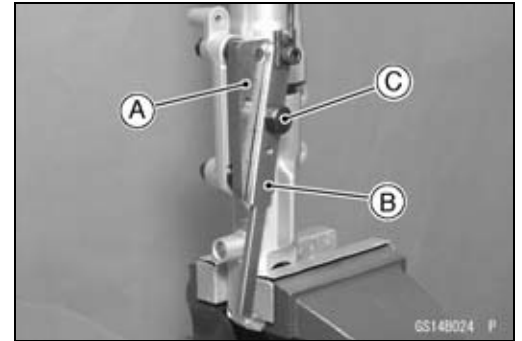

○Compress the outer tube holding the front fork by using the lever [A] of the spring compressor to insert the stopper [B] into the hole [C] with the lever hole aligned with the holder hole.

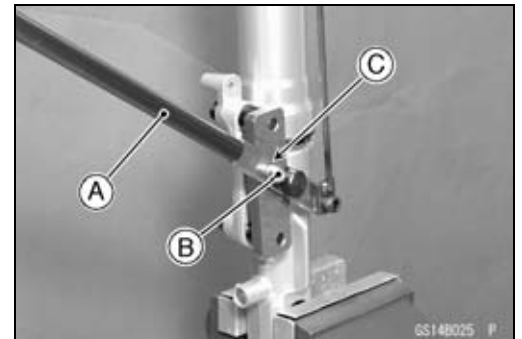

○Holding the piston rod nut [A], remove top plug [B] from the push rod with wrenches.

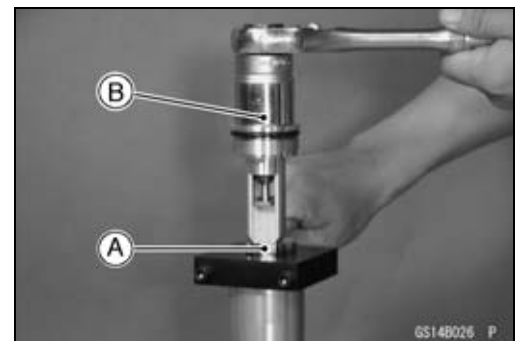

○Push the top of the outer tube to remove the stopper from the spring compressor.
○Remove the front fork spring compressor set.



- Remove:
 - Spacer [A]
 - Spring Seat [B]
 - Fork Spring [C]

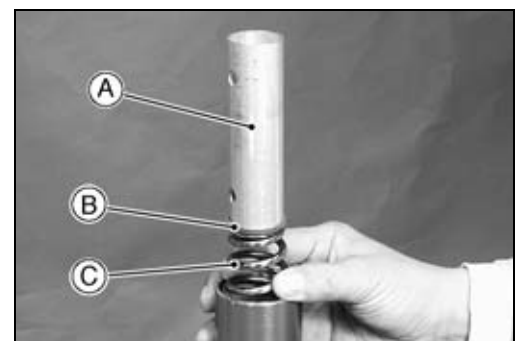

2-34 PERIODIC MAINTENANCE

Periodic Maintenance Procedures

- Remove:
Rebound Damping Adjuster Rod [D]

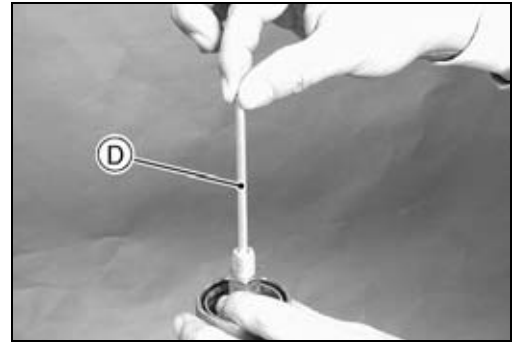

- Drain the fork oil into a suitable container.
- Pump the piston rod [A] up and down at least ten times to expel the oil from the fork.

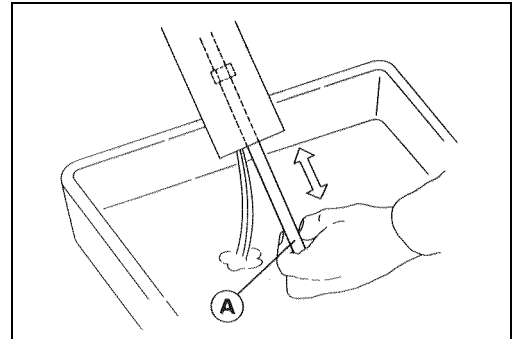

- Hold the fork tube upright, press the outer tube [A] and the piston rod all the way down.
- Pour in the type and amount of fork oil specified.

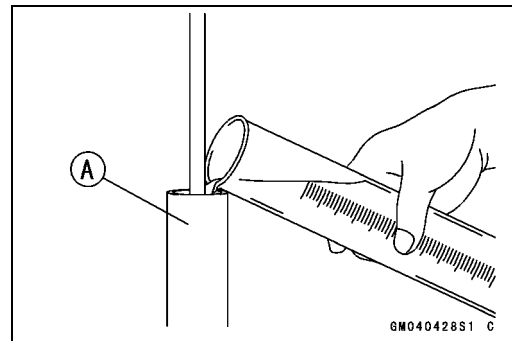

Fork Oil

Viscosity

KAYABA KHL15-10 (SAE 0 W)

Amount (per side):

When changing oil:

approx. 420 mL (14.2 US oz)

After disassembly and completely dry:

490 ±4 mL (16.6 ±0.1 US oz)

- ★ If necessary, measure the oil level as follows.
- Hold the inner tube vertically in a vise.
- Using the piston rod puller [A], move the piston rod [B] up and down more than ten times in order to expel all the air from the fork oil.

Special Tool - Fork Piston Rod Puller, M12 × 1.25: 57001-1289

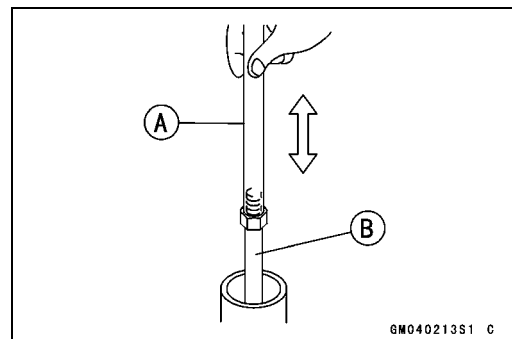

- Pump the inner tube several times to expel air bubbles.
- Remove the piston rod puller.
- Wait until the oil level settles.
- With the fork fully compressed and the piston rod fully pushed in, insert a tape measure or rod into the inner tube, and measure the distance from the top of the outer tube to the oil.

Periodic Maintenance Procedures

Oil Level (fully compressed, without spring)

Standard: 93 ±2 mm (3.66 ±0.08 in.)

(from the top of the outer tube)

NOTE

○Fork oil lever may also be measured using the fork oil level gauge.

Special Tool - Fork Oil Level Gauge: 57001-1290 [A]

- With the fork fully compressed and without fork spring, insert the gauge tube into the inner tube [B] and position the stopper across the top end [F] of the outer tube [C].
- Set the gauge stopper [D] so that its lower side shows the oil level distance specified [E].
- Pull the handle slowly to pump out the excess oil until the oil no longer comes out.
- ★If no oil is pumped out, there is insufficient oil in the inner tube. Pour in enough oil, then pump out the excess oil as shown above.

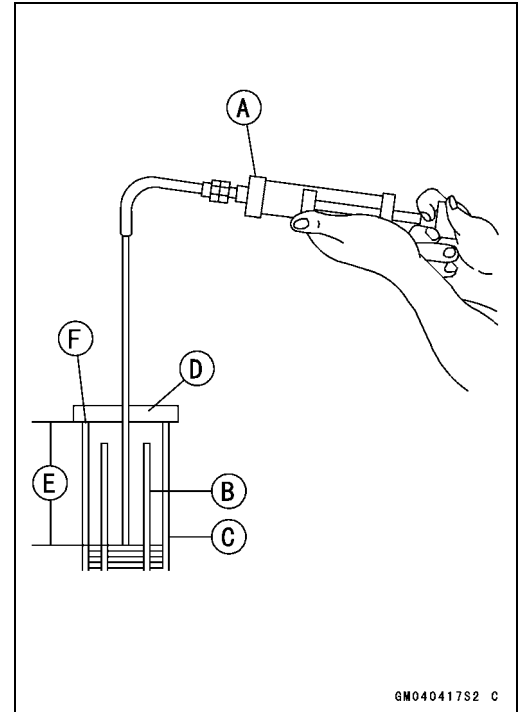

- Install the fork spring [A] with the smaller end facing [B] upward.
- Install:
Spring Seat
Spacer

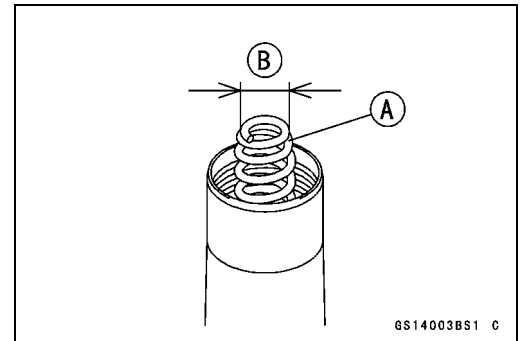

- Screw the fork piston rod puller onto the end of the rod.
Special Tool - Fork Piston Rod Puller, M12 × 1.25: 57001-1289

- Pull the puller up above the inner tube top.
- Remove the fork piston rod puller.
- Screw the rod nut [B] onto the piston rod [A] as shown.
- Insert the rebound damping adjuster rod [C] into the piston rod.

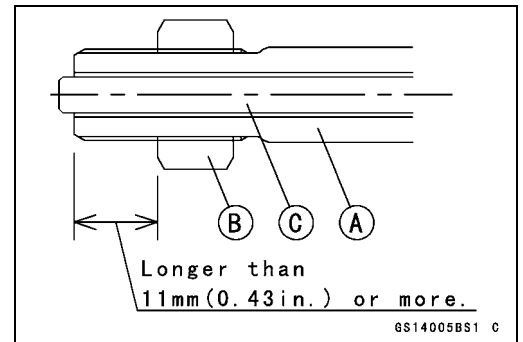

- Check the distance [C] between the bottom end [A] of the top plug and rebound damping adjuster [B] with a pair of vernier caliper.
13 mm (0.51 in.) [C]

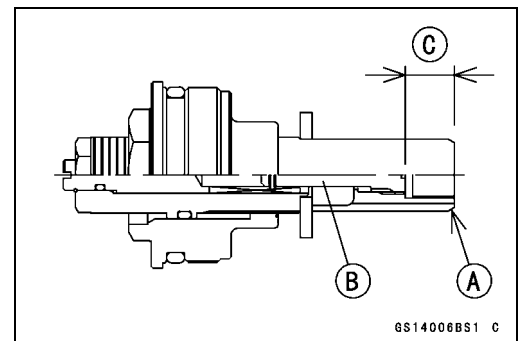

2-36 PERIODIC MAINTENANCE

Periodic Maintenance Procedures

- Hold the spacer and outer tube with the fork spring compressor set [A] to compress it.

Special Tool - Fork Spring Compressor Set: 57001-1452

- Check the O-ring [B] on the top plug and replace it with a new one if damaged.
- Screw in the top plug [C] stopped onto the piston rod.

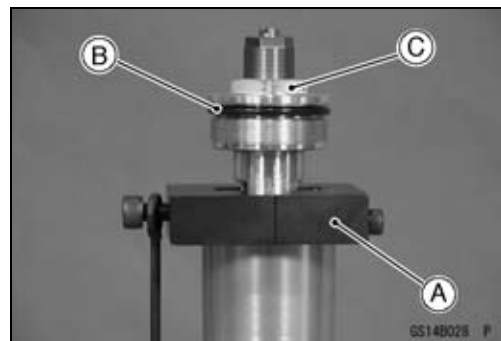

- Holding the top plug [A] with a wrench, tighten the piston rod nut [B] against the top plug.

Torque - Piston Rod Nut: 28 N·m (2.8 kgf·m, 21 ft·lb)

- Remove the fork spring compressor set.

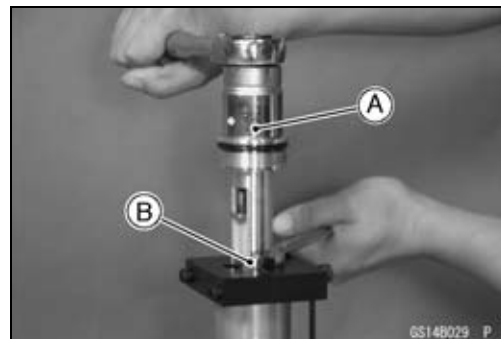

- Raise the outer tube and screw the top plug into it and install it to the steering stem.
- Screw in the spring preload adjuster [A] of the top plug so that the distance between the adjuster top and the top plug surface [C] is 17 mm (0.67 in.) [D].
- Turn in the rebound damping adjuster [B] until the fully tightened position and turn backward the 1 1/2 turns.
- Install the front fork (see Front Fork Installation).

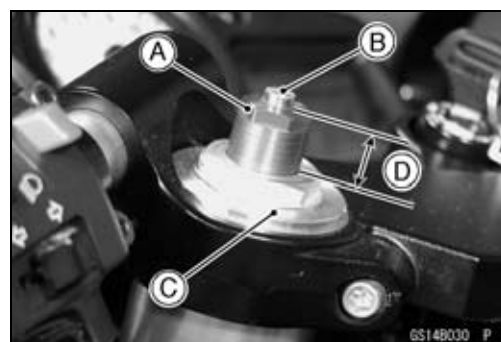

ZX1200-B3

- Remove the front fork (see Front Fork Removal in Suspension chapter).
- Hold the inner tube lower end in a vise.
- Turn the spring preload adjuster [A] counterclockwise until the fully position.
- Turn the rebound damping adjuster [C] clockwise until the fully tightened position.
- Unscrew the top plug [B] out of the inner tube.

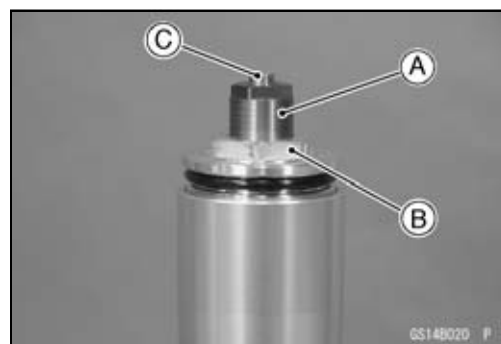

Periodic Maintenance Procedures

- Install the clamps [A] as shown.

NOTE

○ Set the clamps so that the cutout [B] of the upper side does not touch the tongue shape of stopper, pull up the outer tube [C] to hold it by the clamps, and then tighten the two bolts [D]. The outer tube is used as a guide.

Special Tool - Fork Spring Compressor: 57001-1587

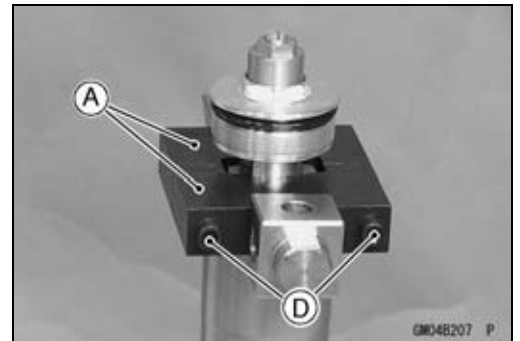
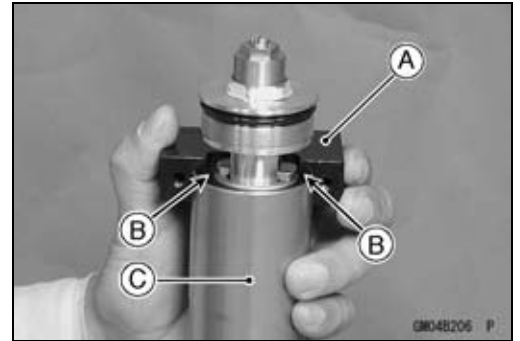

- Insert the holder bar [A] into the axle hole of the front fork [B].

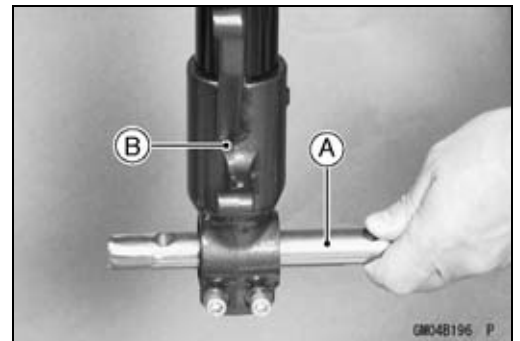

- Insert the compression shaft [A] and install the nut.

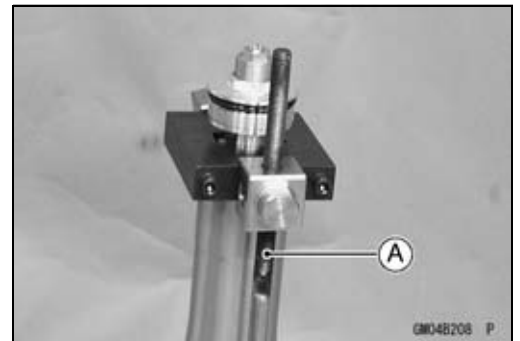

- Insert the lower end of the compression shaft [A] into the hole [B] of the holder bar.

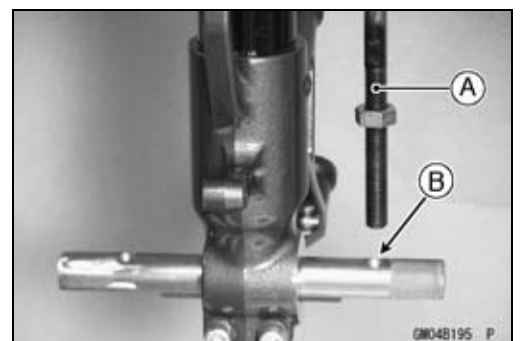

2-38 PERIODIC MAINTENANCE

Periodic Maintenance Procedures

- Screw the adjust nut [A] onto the compression shaft as shown.
- Screw the locknut [B].
- Set the other side compression shaft same process.

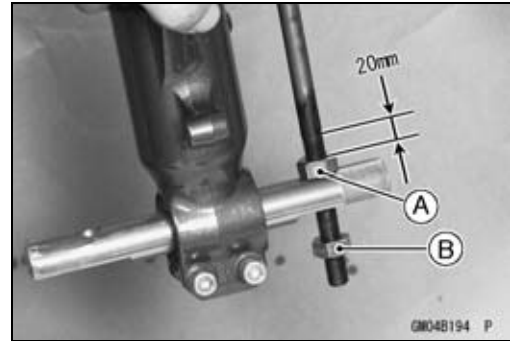

- Screw in one side nut [A] come out the piston rod nut.

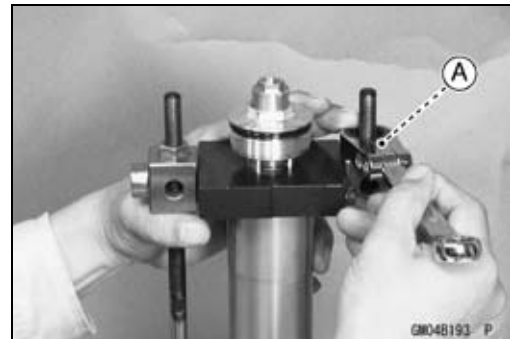

- Holding the piston rod nut with a wrench [A], remove the top plug [B] from the piston rod.

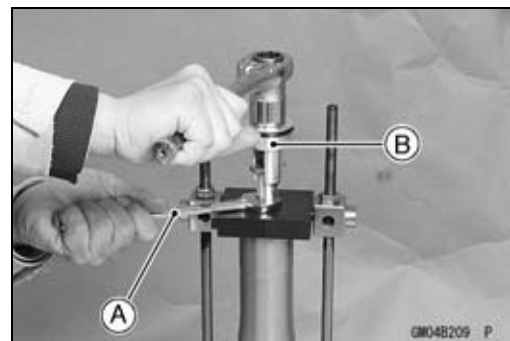

- Remove:
Spacer [A]
Spring Seat [B]
Fork Spring [C]

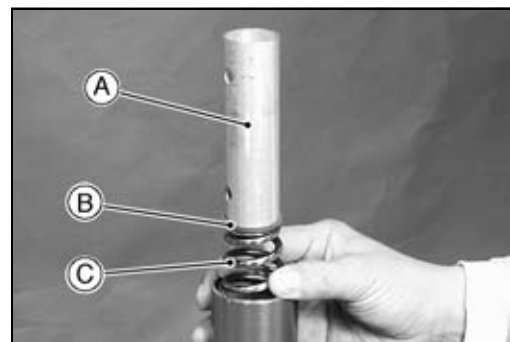

- Remove:
Rebound Damping Adjuster Rod [D]

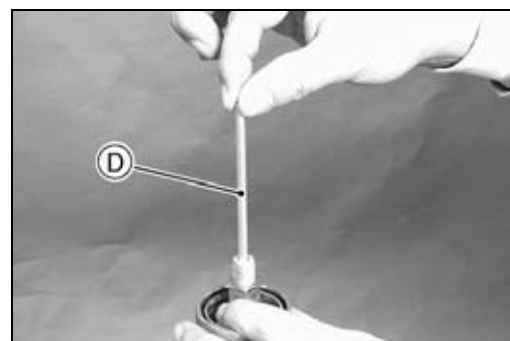

Periodic Maintenance Procedures

- Drain the fork oil into a suitable container.
- Pump the piston rod [A] up and down at least ten times to expel the oil from the fork.

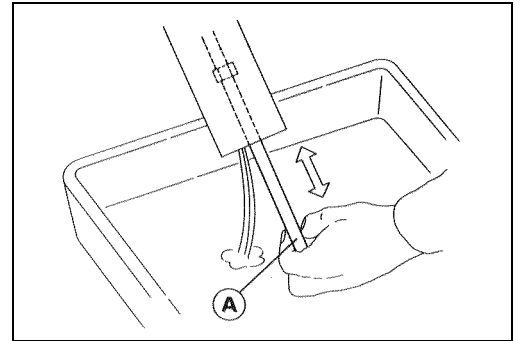

- Hold the fork tube upright, press the outer tube [A] and the piston rod all the way down.
- Pour in the type and amount of fork oil specified.

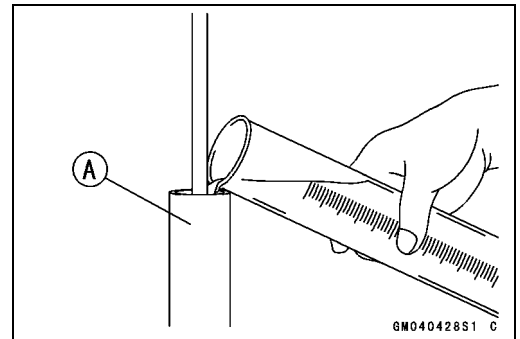

Fork Oil

Viscosity

KAYABA KHL15-10 (SAE 0 W)

Amount (per side):

When changing oil:

approx. 420 mL (14.2 US oz)

After disassembly and completely dry:

490 ±4 mL (16.6 ±0.1 US oz)

★ If necessary, measure the oil level as follows.

- Hold the inner tube vertically in a vise.
- Using the piston rod puller [A], move the piston rod [B] up and down more than ten times in order to expel all the air from the fork oil.

Special Tool - Fork Piston Rod Puller, M12 × 1.25: 57001-1289

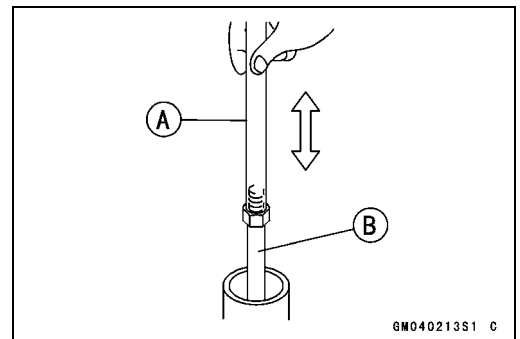

- Pump the inner tube several times to expel air bubbles.
- Remove the piston rod puller.
- Wait until the oil level settles.
- With the fork fully compressed and the piston rod fully pushed in, insert a tape measure or rod into the inner tube, and measure the distance from the top of the outer tube to the oil.

2-40 PERIODIC MAINTENANCE

Periodic Maintenance Procedures

Oil Level (fully compressed, without spring)

Standard: 93 ±2 mm (3.66 ±0.08 in.)

(from the top of the outer tube)

NOTE

○Fork oil lever may also be measured using the fork oil level gauge.

Special Tool - Fork Oil Level Gauge: 57001-1290 [A]

- With the fork fully compressed and without fork spring, insert the gauge tube into the inner tube [B] and position the stopper across the top end [F] of the outer tube [C].
- Set the gauge stopper [D] so that its lower side shows the oil level distance specified [E].
- Pull the handle slowly to pump out the excess oil until the oil no longer comes out.
- ★If no oil is pumped out, there is insufficient oil in the inner tube. Pour in enough oil, then pump out the excess oil as shown above.

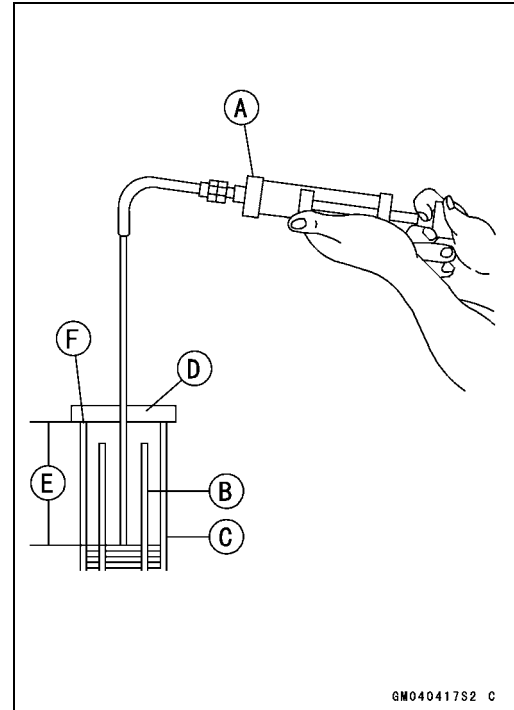

- Install the fork spring [A] with the smaller end facing [B] upward.
- Install:
Spring Seat
Spacer

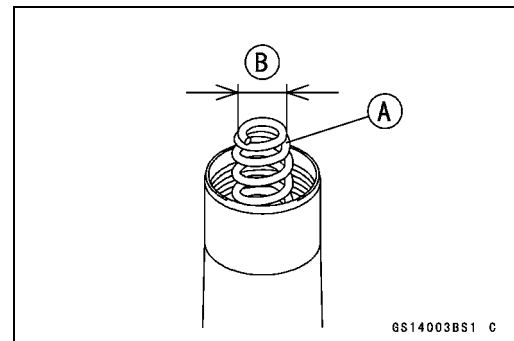

- Screw the fork piston rod puller onto the end of the rod.
Special Tool - Fork Piston Rod Puller, M12 × 1.25: 57001-1289

- Pull the puller up above the inner tube top.
- Remove the fork piston rod puller.
- Screw the rod nut [B] onto the piston rod [A] as shown.
- Insert the rebound damping adjuster rod [C] into the piston rod.

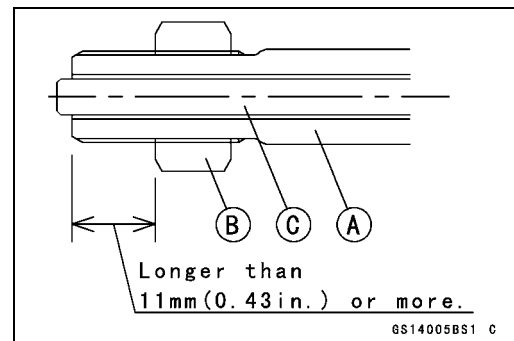

- Check the distance [C] between the bottom end [A] of the top plug and rebound damping adjuster [B] with a pair of vernier caliper.
13 mm (0.51 in.) [C]

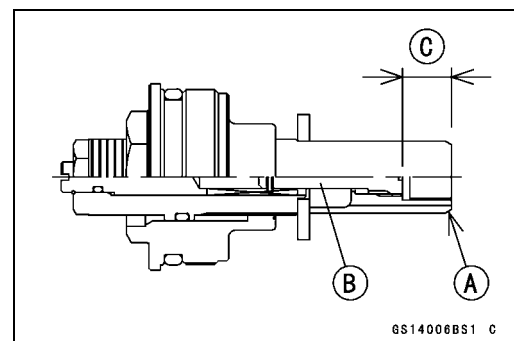

Periodic Maintenance Procedures

- Set the fork spring compressor on the spacer using the outer tube as a guide.

Special Tool - Fork Spring Compressor: 57001-1587

NOTE

○Set the clamps so that the cutout [A] of the upper side does not fit the hole [B] of spacer [C], pull up the outer tube [D] to hold it by the clamps, and then tighten the two bolts [E]. The outer tube is used as a guide.

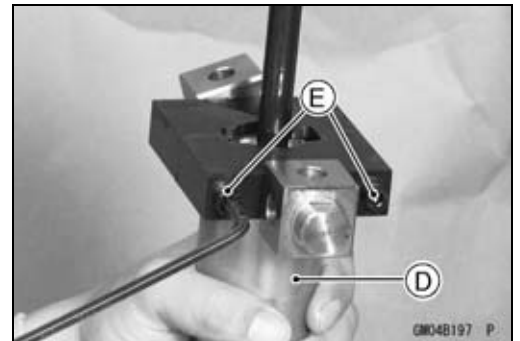
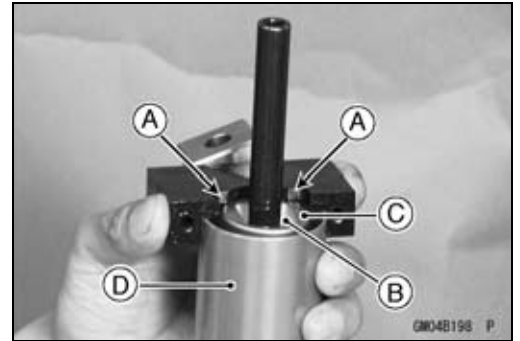

- Set the holder bar [A], and compression shafts [B].

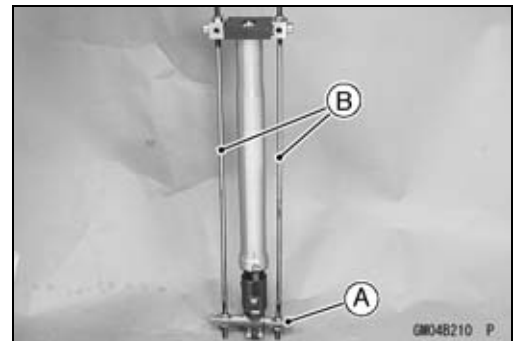

- Hold the piston rod nut [A].
- Remove the piston rod puller [B].

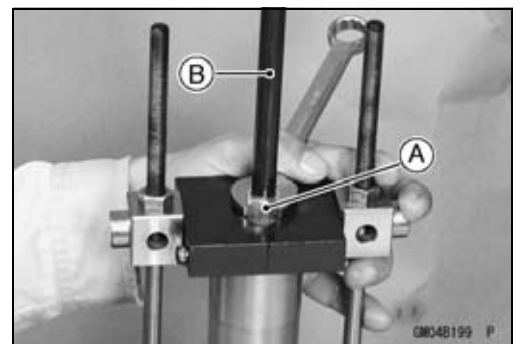

- Install the rebound damping adjuster rod [A].

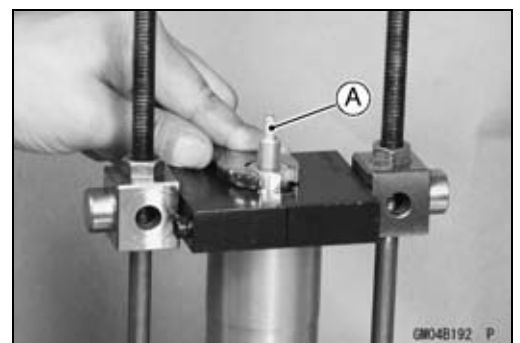

2-42 PERIODIC MAINTENANCE

Periodic Maintenance Procedures

- Screw in the top plug [A] stopped onto the piston rod.
- Check the O-ring [B] on the top plug and replace it with a new one if damaged.
- Holding the top plug with a wrench, tighten the piston rod nut [C] against the top plug.

Torque - Piston Rod Nut: 28 N·m (2.8 kgf·m, 21 ft·lb)

- While holding up the fork spring compressor, pull out the fork spring stopper.
- Remove the fork spring compressor.

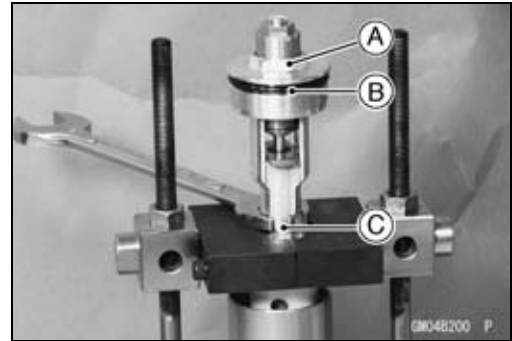

- Raise the outer tube and screw the top plug into it and install it to the steering stem.
- Screw in the spring preload adjuster [A] of the top plug so that the distance between the adjuster top and the top plug surface [C] is 17 mm (0.67 in.) [D].
- Turn in the rebound damping adjuster [B] until the fully tightened position and turn backward the 7th click.
- Install the front fork (see Front Fork Installation).

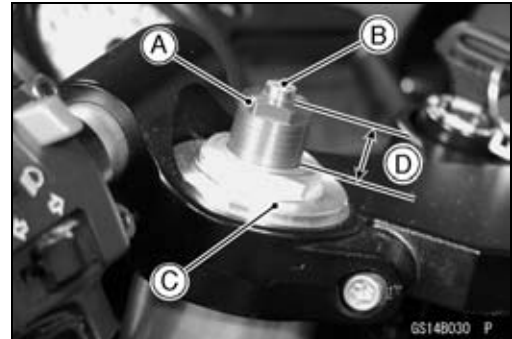

Front Fork Oil Leak Inspection

- Visually inspect the front forks [A] for oil leakage, scoring or scratches on the outer surface of the outer tubes.
- ★ Replace or repair any defective parts, if necessary.

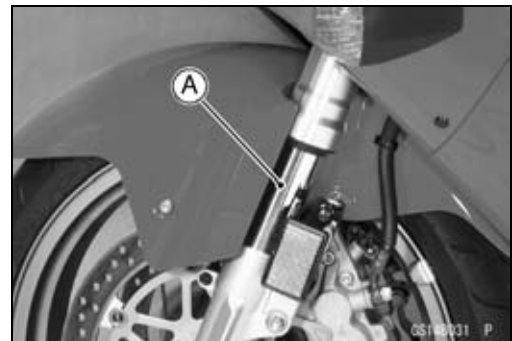

Rear Shock Absorber Oil Leak Inspection

- Visually inspect the shock absorbers [A] for oil leakage.
- ★ If they are oil leaked, one unit feels weaker than the other, replace both shock absorber as a set.

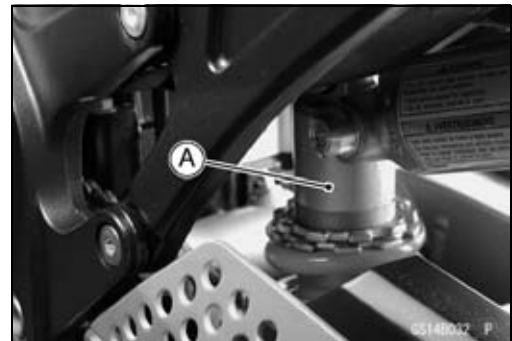

Swingarm Pivot Lubrication

- The grease nipple [A] is equipped for the lubrication of swingarm bearing. Force grease into the nipple until the grease comes out from right side of the swingarm pivot, and wipe off any excess of it.



Periodic Maintenance Procedures

Unit-trak Linkage Lubrication

In order for the tie-rod and rocker arm to function safely and wear slowly, it should be lubricated in accordance with the Periodic Maintenance Chart.

- For the rocker arm and tie-rod needle bearings, there are grease nipples [A] on the rocker arm and swingarm for lubrication. Force grease into the nipples until it comes out at both sides of the rocker arm and tie-rod, and wipe off any excess.

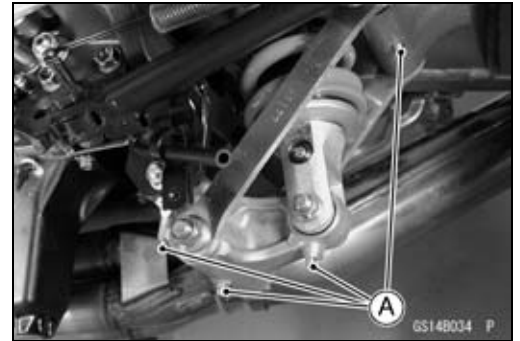

Steering

Steering Inspection

- Remove:
 - Lower Fairings (see Frame chapter)
- Check the steering.
- Lift the front wheel off the ground using the jack.

Special Tool - Jack: 57001-1238

- With the front wheel pointing straight ahead, alternately tap each end of the handlebar. The front wheel should swing fully left and right from the force of gravity until the fork hits the stop.
- ★ If the wheel binds or catches before the stop, the steering is too tight.
- Feel for steering looseness by pushing and pulling the forks.
- ★ If you feel looseness, the steering is too loose.



NOTE

- *The cables and wiring will have some effect on the motion of the fork which must be taken into account. Be sure the leads and cables are properly routed.*
- *The bearings must be in good condition and properly lubricated in order for any test to be valid.*

ZX1200-B1/B2

- Remove the stem head nut to take off the lock washer [A].



2-44 PERIODIC MAINTENANCE

Periodic Maintenance Procedures

- Adjust the steering.

Special Tool - Steering Stem Nut Wrench: 57001-1100 [B]

- ★ If the steering is too tight, loosen the stem nut [A] a fraction of a turn.
- ★ If the steering is too loose, tighten the nut a fraction of a turn.

NOTE

○ Turn the stem nut 1/8 turn at a time maximum.

- Tighten the head nut.

Torque - Steering Stem Head Nut: 54 N·m (5.5 kgf·m, 40 ft·lb)

- Check the steering again

- ★ If the steering is still too tight or too loose, repeat the adjustment.

ZX1200-B3

- Loosen the upper fork clamp bolts on both side.
- Remove the stem head nut and washer.
- Remove the steering stem head together with the handlebar installed.
- Bend the claw washer tabs [A].
- Remove the steering stem locknut [B] and claw washer [C].

- Adjust the stem nut [A] with the stem nut wrench [B] by tightening to the specified torque.

Special Tool - Steering Stem Nut Wrench: 57001-1100

Torque - Steering Stem Nut: 20 N·m (2.0 kgf·m, 15 ft·lb)

NOTE

○ Turn the stem nut 1/8 turn at time maximum.

- Install the claw washer [A] so that its bent side [B] faces upward, and engage the bent claws with the grooves of stem locknut [C].
- Hand tighten the stem locknut until it touches the claw washer.
- Tighten the stem locknut clockwise until the claws are aligned with the grooves of stem nut [D], and bend the 2 claws downward [E].

- Tighten:

Torque - Steering Stem Head Nut: 78 N·m (8.0 kgf·m, 57 ft·lb)

Front Fork Clamp Bolts (Upper): 20 N·m (2.0 kgf·m, 14 ft·lb)

- Check the steering again.

- ★ If the steering is still too tight or too loose, repeat the adjustment.

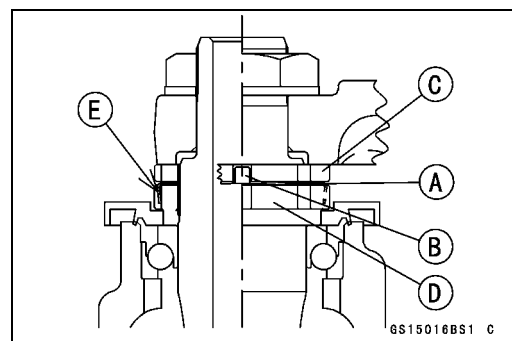
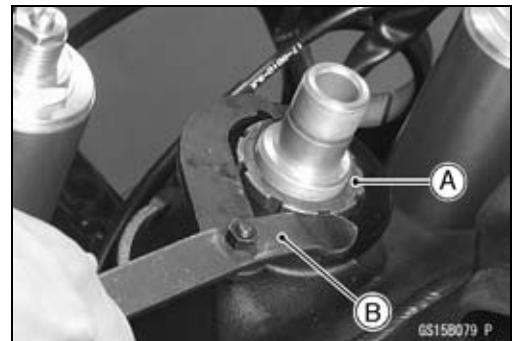
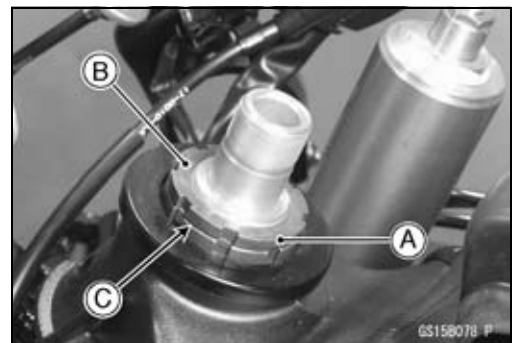
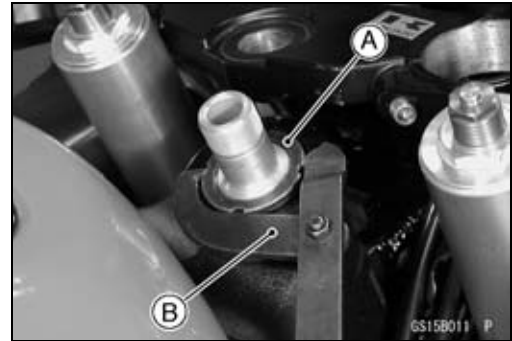

Periodic Maintenance Procedures

Steering Stem Bearing Lubrication

- Remove the steering stem.
- Using a high flash-point solvent, wash the upper and lower ball bearings in the cages, and wipe the upper and lower outer races, which are press-fitted into the frame head pipe, clean off old grease and dirt.
- Visually check the outer races and the ball bearings.
- ★ Replace the bearing assemblies if they show wear or damage.
- Pack the upper and lower ball bearings [A] in the cages with grease, and apply a light coat of grease to the upper and lower outer races.
- Install the steering stem, and adjust the steering.

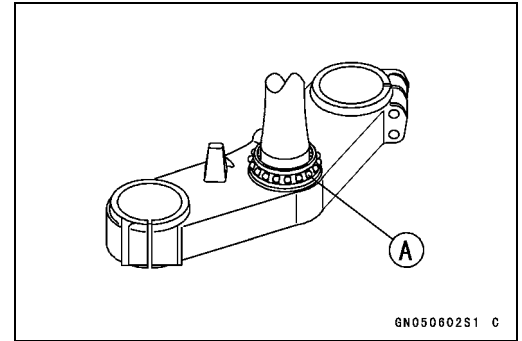

Electrical System

Spark Plug Cleaning and Inspection

- Remove the spark plug (see Electrical System chapter).
- Clean the spark plug, preferably in a sandblasting device, and then clean off any abrasive particles. The plug may also be cleaned using a brush or other suitable tool.
- ★ If the spark plug electrodes are corroded or damaged, or if the insulator is cracked, replace the plug. Use the standard spark plug or optional spark plug.
- Measure the gap [A] with a wire-type thickness gauge.
- ★ If the gaps are incorrect, carefully bend the side electrode [B] with a suitable tool to obtain the correct gaps.

Spark Plug Gap: 0.7 ~ 0.9 mm (0.028 ~ 0.035 in.)

- Install the spark plugs (see Electrical System chapter).

Torque - Spark Plugs: 13 N·m (1.3 kgf·m, 115 in·lb)

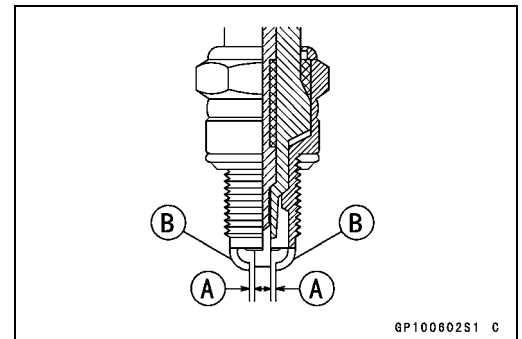

General Lubrication

Lubrication Perform

- Before lubricating each part, clean off any rusty spots with rust remover and wipe off any grease, oil, dirt, or grime.
- Lubricate the points listed below with indicated lubricant.

NOTE

- Whenever the vehicle has been operated under wet or rainy conditions, or especially after using a high-pressure water spray, perform the general lubrication.

2-46 PERIODIC MAINTENANCE

Periodic Maintenance Procedures

Points: Lubricate with Grease.

- Clutch Inner Cable Upper and Lower Ends [A]
- Throttle Inner Cable Upper and Lower Ends
- Choke Inner Cable Upper and Lower Ends
- Clutch Lever Pivot (Apply silicone grease)
- Brake Lever Pivot (Apply silicone grease)
- Brake Pedal Pivot
- Rear Brake Push Rod Joint
- Side Stand
- Tie-Rod Pivots
- Rocker Arm Pivots

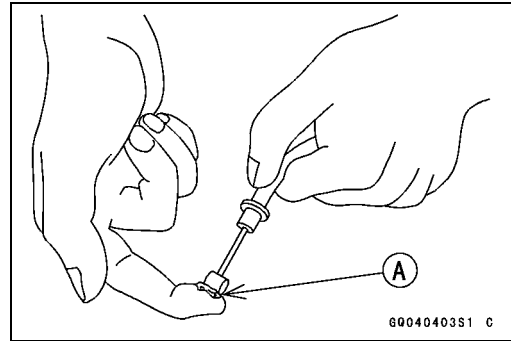

Cables: Lubricate with Cable Lubricant.

- Choke Cable
- Throttle Cables
- Clutch Cable

- Lubricate the cables by seeping the oil between the cable and housing.
- The cable may be lubricated by using a commercially available pressure cable lubricator with an aerosol cable lubricant.

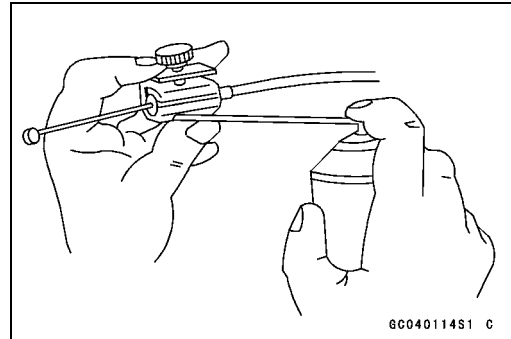

- With the cable disconnected at both ends, the cable should move freely [A] within the cable housing.
- ★ If cable movement is not free after lubricating, if the cable is frayed [B], or if the cable housing is kinked [C], replace the cable.

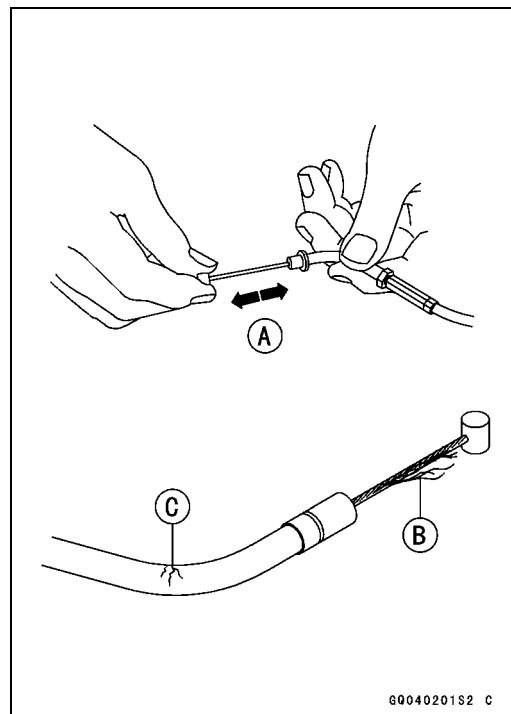

Periodic Maintenance Procedures

Nut, Bolt, and Fastener Tightness

Tightness Inspection

- Check the tightness of the bolts and nuts listed here. Also, check to see that each cotter pin is in place and in good condition.

NOTE

○ *For the engine fasteners, check the tightness of them when the engine is cold (at room temperature).*

- ★ If there are loose fasteners, retighten them to the specified torque following the specified tightening sequence. Refer to the appropriate chapter for torque specifications. If torque specifications are not in the appropriate chapter, see the Basic Torque for General Fasteners Table. For each fastener, first loosen it by 1/2 turn, then tighten it.
- ★ If cotter pins are damaged, replace them with new ones.

Nut, Bolt and Fastener to be checked

Wheels:

- Front Axle Nut
- Front Axle Clamp Bolt
- Rear Axle Nut
- Rear Axle Nut Cotter Pin

Brakes:

- Front Master Cylinder Clamp Bolts
- Caliper Mounting Bolts
- Caliper Assembly Bolts
- Rear Master Cylinder Mounting Bolts
- Brake Lever Pivot Nut
- Brake Pedal Bolt
- Brake Rod Joint Cotter Pin

Suspension:

- Front Fork Clamp Bolts
- Front Fender Mounting Screws
- Rear Shock Absorber Mounting Nuts
- Swingarm Pivot Shaft Nut
- Uni-Track Link Nuts

Steering:

- Stem Head Nut
- Handlebar Mounting Bolts

Engine:

- Engine Mounting Bolts and Nuts
- Shift Pedal Bolt
- Muffler Mounting Bolts
- Exhaust Pipe Holder Nuts
- Muffler Connecting Clamp Bolt
- Clutch Lever Pivot Nut

Others:

- Side Stand Bolt
- Footpeg Mounting Bolts
- Footpeg Bracket Mounting Bolts

Fuel System (DFI)

Table of Contents

Exploded View.....	3-3	Self-diagnosis Procedures.....	3-59
Specifications	3-12	How to Read Service Codes.....	3-61
Throttle Grip and Cables	3-15	How to Erase Service Codes.....	3-62
Free Play Inspection	3-15	Backups	3-64
Free Play Adjustment.....	3-15	Throttle Sensor (Service Code 11)	
Cable Installation	3-15	(ZX1200-B1/B2).....	3-67
Cable Lubrication.....	3-15	Throttle Sensor	
Choke Cable.....	3-16	Removal/Adjustment.....	3-67
Free Play Inspection	3-16	Input Voltage Inspection.....	3-67
Free Play Adjustment.....	3-16	Output Voltage Inspection.....	3-68
Choke Cable Installation.....	3-16	Resistance Inspection.....	3-70
Cable Lubrication	3-16	Main Throttle Sensor (Service Code	
Throttle Body Assy	3-17	11) (ZX1200-B3).....	3-72
Idle Speed Inspection	3-17	Main Throttle Sensor	
Throttle Bore Cleaning.....	3-17	Removal/Adjustment.....	3-72
Synchronization Inspection.....	3-17	Input Voltage Inspection.....	3-72
Synchronization Adjustment	3-17	Output Voltage Inspection.....	3-73
Throttle Body Assy Removal.....	3-17	Resistance Inspection.....	3-74
Throttle Body Assy Installation.....	3-20	Inlet Air Pressure Sensor (Service	
Throttle Body Assy Disassembly .	3-22	Code 12).....	3-75
Throttle Body Assy Assembly	3-24	Removal.....	3-75
Air Line	3-26	Installation.....	3-76
Element Removal.....	3-26	Input Voltage Inspection.....	3-76
Element Installation.....	3-26	Output Voltage Inspection.....	3-77
Air Cleaner Element Cleaning and		Inlet Air Temperature Sensor (Service	
Inspection.....	3-26	Code 13).....	3-81
Oil Draining	3-26	Removal/Installation.....	3-81
Air Inlet Duct Removal	3-27	Output Voltage Inspection.....	3-81
Air Inlet Duct Installation	3-27	Sensor Resistance Inspection	3-82
Front Duct Removal/Installation...	3-27	Water Temperature Sensor (Service	
Fuel Tank	3-28	Code 14).....	3-84
Fuel Tank Removal	3-28	Removal/Installation.....	3-84
Fuel Tank Installation	3-30	Output Voltage Inspection.....	3-84
Fuel Tank Inspection	3-30	Sensor Resistance Inspection	3-86
Fuel Tank Cleaning	3-31	Atmospheric Pressure Sensor	
DFI System.....	3-32	(Service Code 15).....	3-87
DFI Servicing Precautions.....	3-40	Removal.....	3-87
Troubleshooting the DFI System	3-42	Installation.....	3-87
Outline	3-42	Input Voltage Inspection.....	3-87
Inquiries to Rider.....	3-46	Output Voltage Inspection.....	3-88
DFI System Troubleshooting Guide ..	3-49	Crankshaft Sensor (Service Code	
DFI System Troubleshooting		21).....	3-92
Guide.....	3-49	Crankshaft Sensor	
Self-Diagnosis	3-58	Removal/Installation.....	3-92
Self-diagnosis Outline.....	3-58	Crankshaft Sensor Inspection.....	3-92
Self-diagnosis Function	3-58		

3-2 FUEL SYSTEM (DFI)

Camshaft Position Sensor (Service Code 23).....	3-94	Fuel Pump Relay Removal	3-122
Camshaft Position Sensor Removal/Installation.....	3-94	Operating Voltage Inspection.....	3-122
Camshaft Position Sensor Inspection.....	3-94	Power Source Voltage Inspection	3-124
Speed Sensor (Service Code 24).....	3-96	Relay Inspection	3-125
Speed Sensor Removal/Installation.....	3-96	Stick Coils (#1, #2, #3, #4: Service Code 51, 52, 53, 54).....	3-127
Speed Sensor Inspection.....	3-96	Removal/Installation.....	3-127
Gear Position Switch (Service Code 25).....	3-98	Input Voltage Inspection.....	3-127
Gear Position Switch Removal	3-98	Subthrottle Valve Actuator (Service Code 62) (ZX1200-B3)	3-131
Gear Position Switch Installation	3-98	Subthrottle Valve Actuator Removal	3-131
Gear Position Switch Input Voltage Inspection.....	3-99	Audible Inspection.....	3-131
Gear Position Switch Inspection	3-100	Visual Inspection.....	3-131
Vehicle-down Sensor (Service Code 31).....	3-103	Resistance Inspection.....	3-131
Removal.....	3-103	Input Voltage Inspection.....	3-132
Installation.....	3-104	ECU.....	3-133
Inspection.....	3-104	ECU Removal	3-133
Subthrottle Sensor (Service Code 32) (ZX1200-B3)	3-108	ECU Installation	3-133
Subthrottle Sensor Removal/Adjustment	3-108	ECU Power Supply Inspection....	3-133
Input Voltage Inspection.....	3-108	DFI Power Source	3-137
Output Voltage Inspection.....	3-109	ECU Fuse Removal	3-137
Resistance Inspection.....	3-110	ECU Fuse Installation	3-137
Immobilizer Amplifier (Service Code 35) (ZX1200-B3).....	3-111	ECU Fuse Inspection.....	3-137
Antenna Resistance Inspection	3-111	ECU Main Relay Removal	3-137
Amplifier Input Voltage Inspection	3-111	ECU Main Relay Inspection	3-137
Blank Key Detection (Service Code 36) (ZX1200-B3).....	3-112	FI Indicator LED Light.....	3-138
User Key Inspection.....	3-112	LED Light Inspection.....	3-139
Fuel Injectors (#1, #2, #3, #4: Service Code 41, 42, 43, 44).....	3-113	Fuel Line.....	3-141
Power Source Voltage Inspection	3-113	Fuel Pressure Inspection	3-141
Output Voltage Inspection.....	3-115	Fuel Flow Rate Inspection	3-142
Audible Inspection.....	3-116	In-tank Fuel Pump	3-144
Injector Signal Test.....	3-117	Fuel Pump Removal	3-144
Injector Resistance Inspection	3-118	Pump Screen Cleaning	3-145
Injector Unit Test	3-118	Fuel Pump Installation	3-145
Injector Fuel Line Inspection	3-119	Operation Inspection.....	3-146
Fuel Pump Relay (Service Code 45, 46).....	3-122	Operating Voltage Inspection.....	3-146
		Evaporative Emission Control System.....	3-149
		Parts Removal/Installation	3-149
		Hose Inspection	3-149
		Separator Inspection.....	3-149
		Separator Operation Test.....	3-150
		Canister Inspection (California Model Only).....	3-150

Exploded View

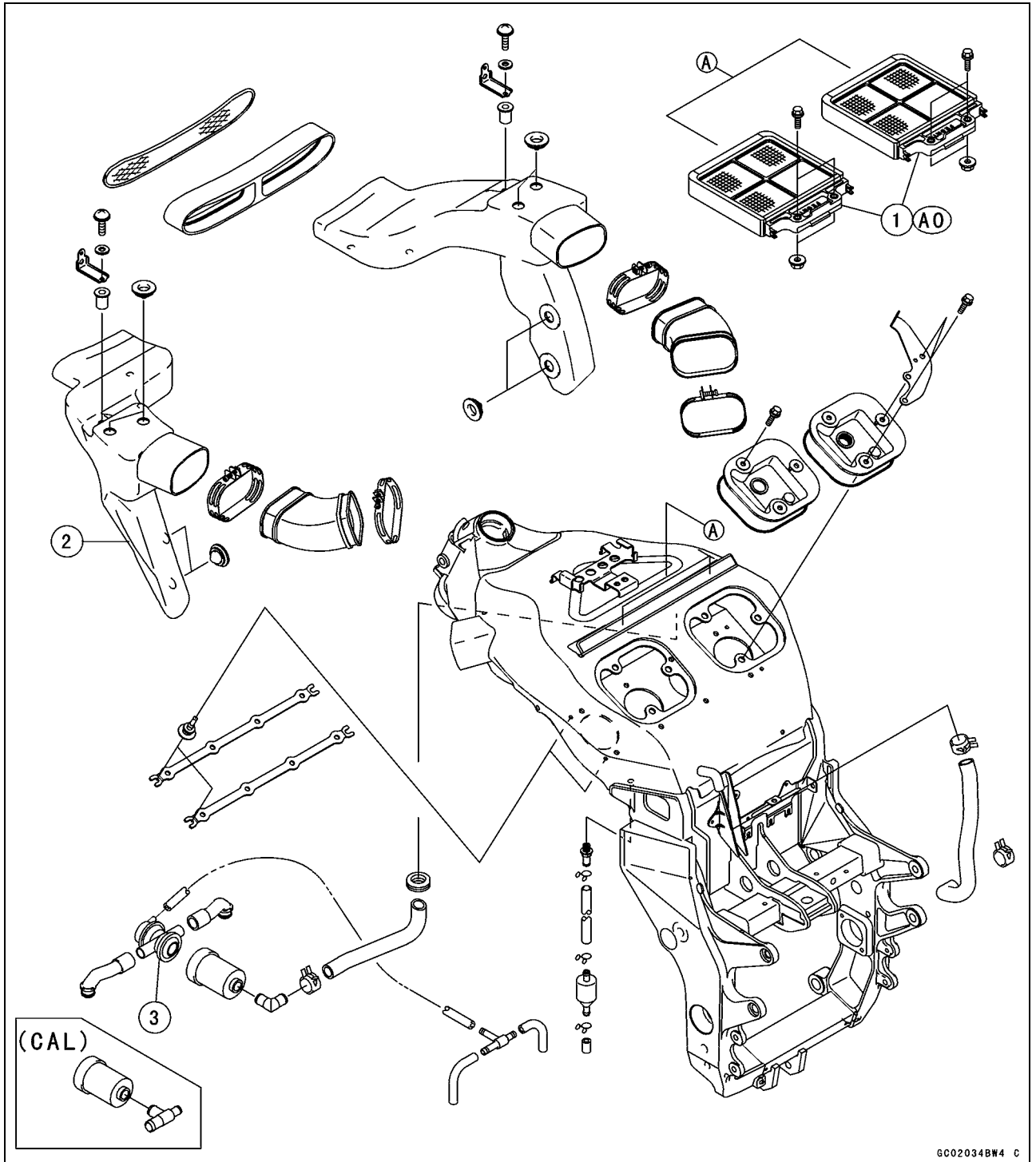

1. Air Cleaner Elements

2. Ducts

3. Vacuum Switch Valve

AO: Apply high-quality-form-air-filter oil.

CAL: California Model

3-4 FUEL SYSTEM (DFI)

Exploded View

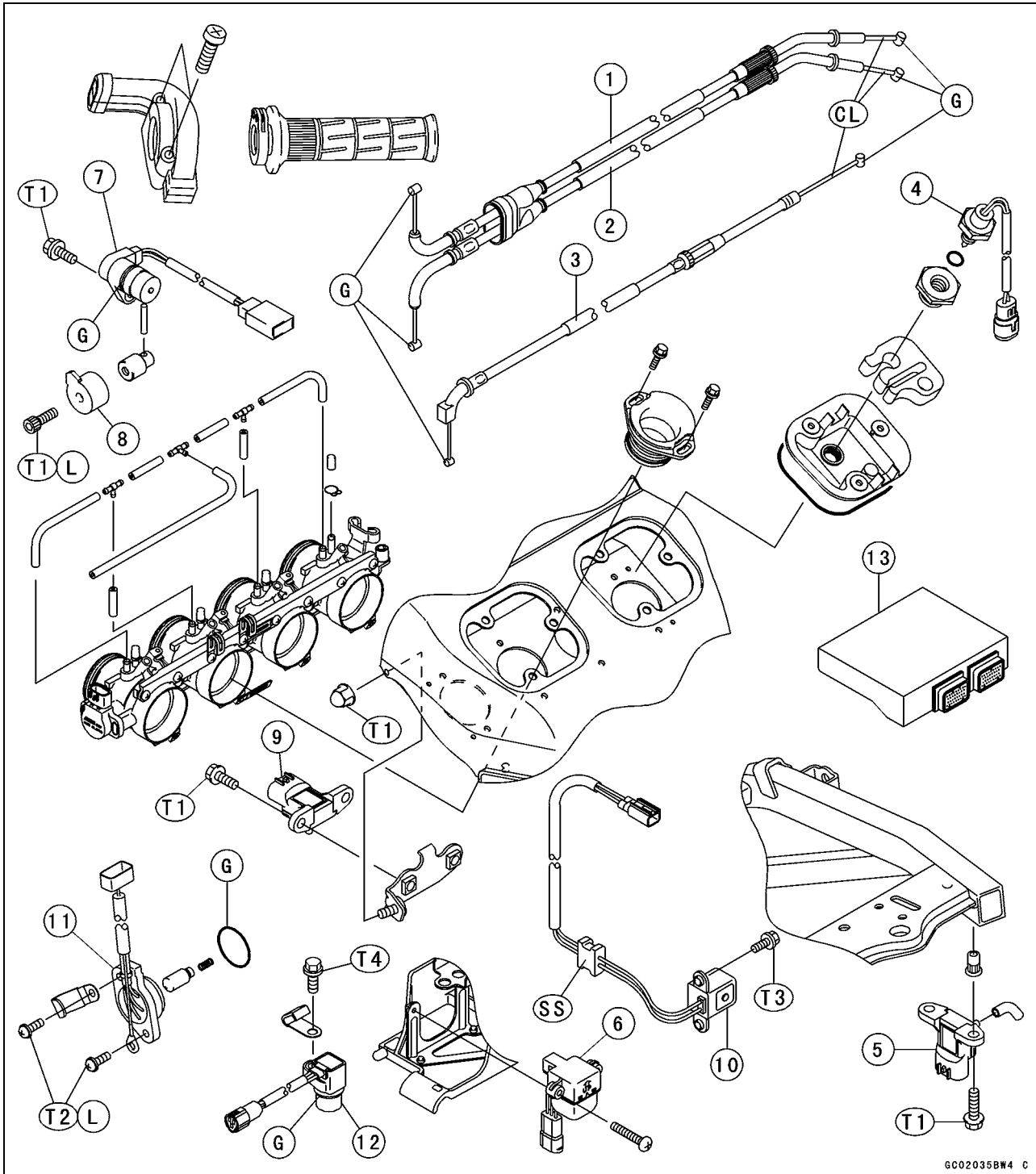

GC02035BW4 C

T1: 12 N·m (1.2 kgf·m, 106 in·lb)

T2: 4.0 N·m (0.40 kgf·m, 35 in·lb)

T3: 6.0 N·m (0.60 kgf·m, 53 in·lb)

T4: 10 N·m (1.0 kgf·m, 89 in·lb)

1. Throttle Cable (accelerator)

2. Throttle Cable (decelerator)

3. Choke Cable

4. Inlet Temperature Sensor

5. Atmospheric Pressure Sensor

6. Vehicle-down Sensor

7. Camshaft Position Sensor

8. Camshaft Position Sensor Rotor

9. Inlet Pressure Sensor

10. Crankshaft Sensor

11. Gear Position Switch

12. Speed Sensor

13. Electrical Control Unit

CL: Apply cable lubricant.

G: Apply grease.

L: Apply a non-permanent locking agent.

SS: Apply silicone sealant.

Exploded View

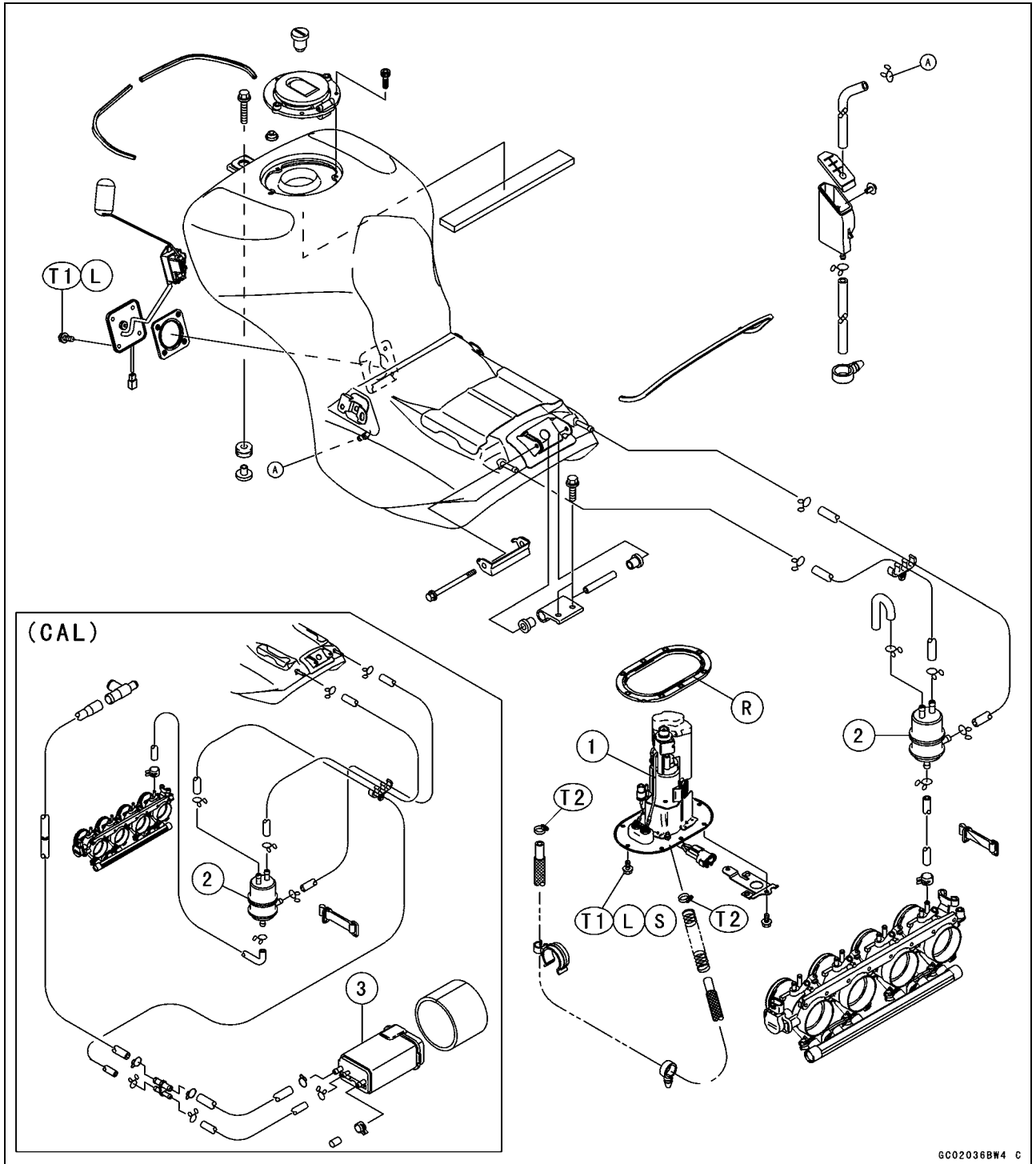

GC02036BW4 C

T1: 6.9 N·m (0.70 kgf·m, 61 in·lb)

T2: 1.5 N·m (0.15 kgf·m, 13 in·lb)

1. Fuel Pump

2. Separator

3. Canister

L: Apply a non-permanent locking agent.

R: Replacement Parts

S: Tighten the fasteners following the specified sequence.

CAL: California Model

3-6 FUEL SYSTEM (DFI)

Exploded View

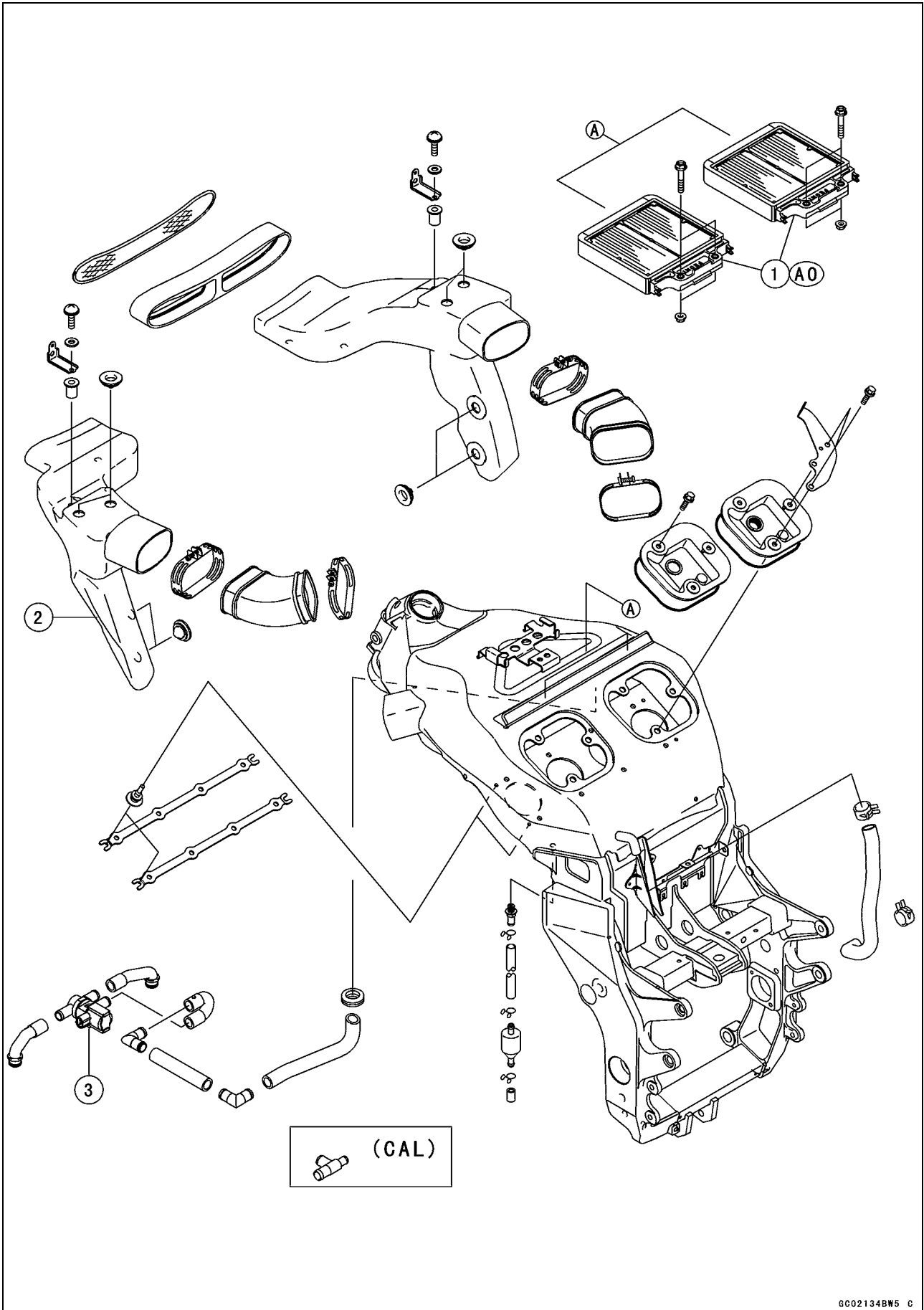

Exploded View

1. Air Cleaner Elements
2. Ducts
3. Air Switching Valve

AO: Apply high-quality-form-air-filter oil.

CAL: California Model

3-8 FUEL SYSTEM (DFI)

Exploded View

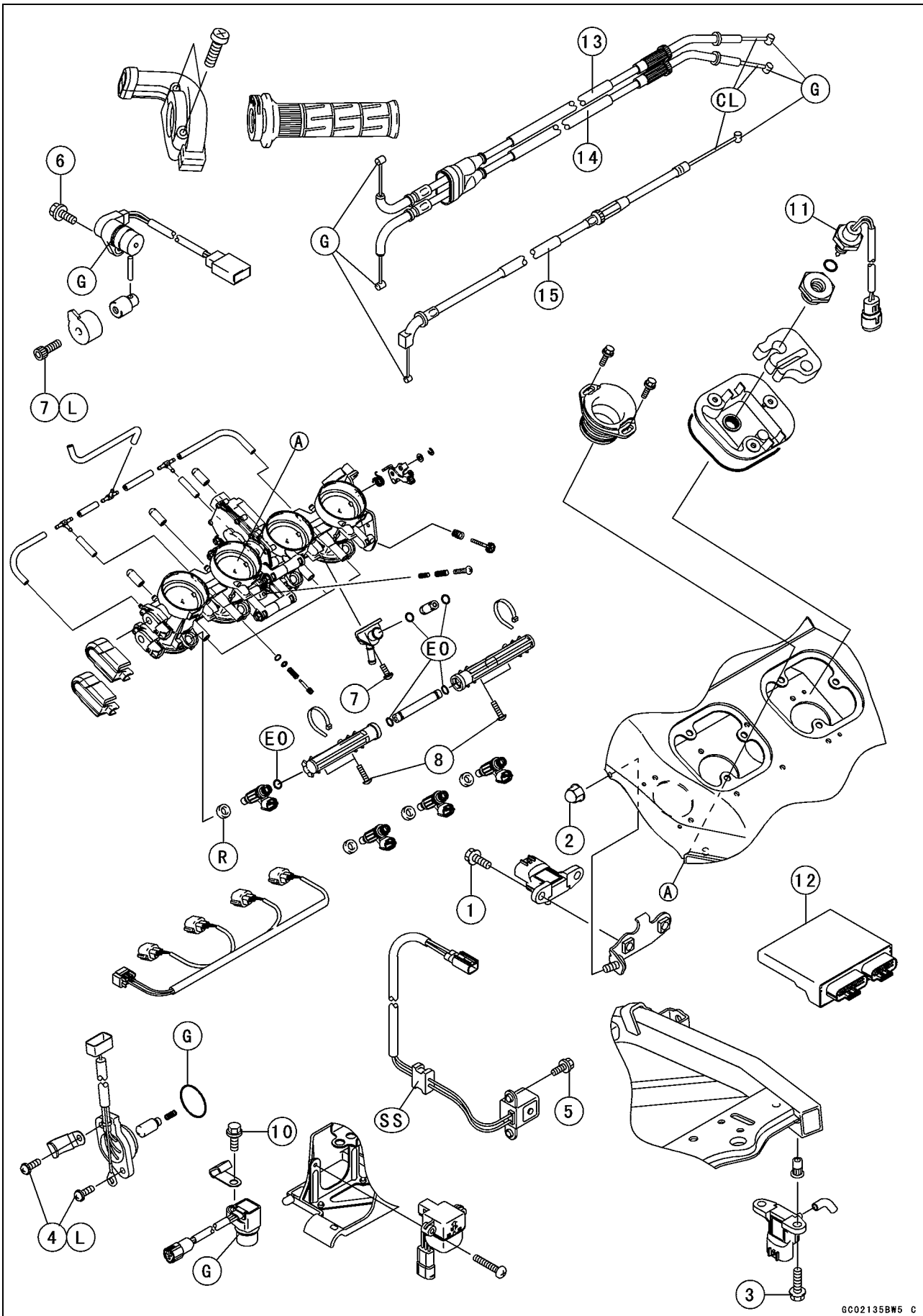

Exploded View

No.	Fastener	Torque			Remarks
		N·m	kgf·m	ft·lb	
1	Inlet Air Pressure Sensor Bolt	12	1.2	106 in·lb	
2	Inlet Air Temperature Sensor Bracket Nut	12	1.2	106 in·lb	
3	Atmospheric Pressure Sensor	12	1.2	106 in·lb	
4	Gear Position Switch Screws	4.0	0.40	35 in·lb	L
5	Crankshaft Sensor Bolts	6.0	0.60	53 in·lb	
6	Camshaft Position Sensor Bolt	12	1.2	106 in·lb	
7	Camshaft Position Sensor Rotor Bolt	12	1.2	106 in·lb	L
8	Delivery Pipe Screws	5.0	0.50	44 in·lb	
9	Nipple Assy Screws	3.4	0.35	31 in·lb	
10	Speed Sensor Bolt	10	1.0	89 in·lb	

11. Inlet Temperature Sensor

12. ECU

13. Throttle Cable (accelerator)

14. Throttle Cable (decelerator)

15. Choke Cable

CL: Apply cable lubricant.

EO: Apply engine oil.

G: Apply grease.

L: Apply a non-permanent locking agent.

R: Replacement Parts

SS: Apply silicone sealant.

3-10 FUEL SYSTEM (DFI)

Exploded View

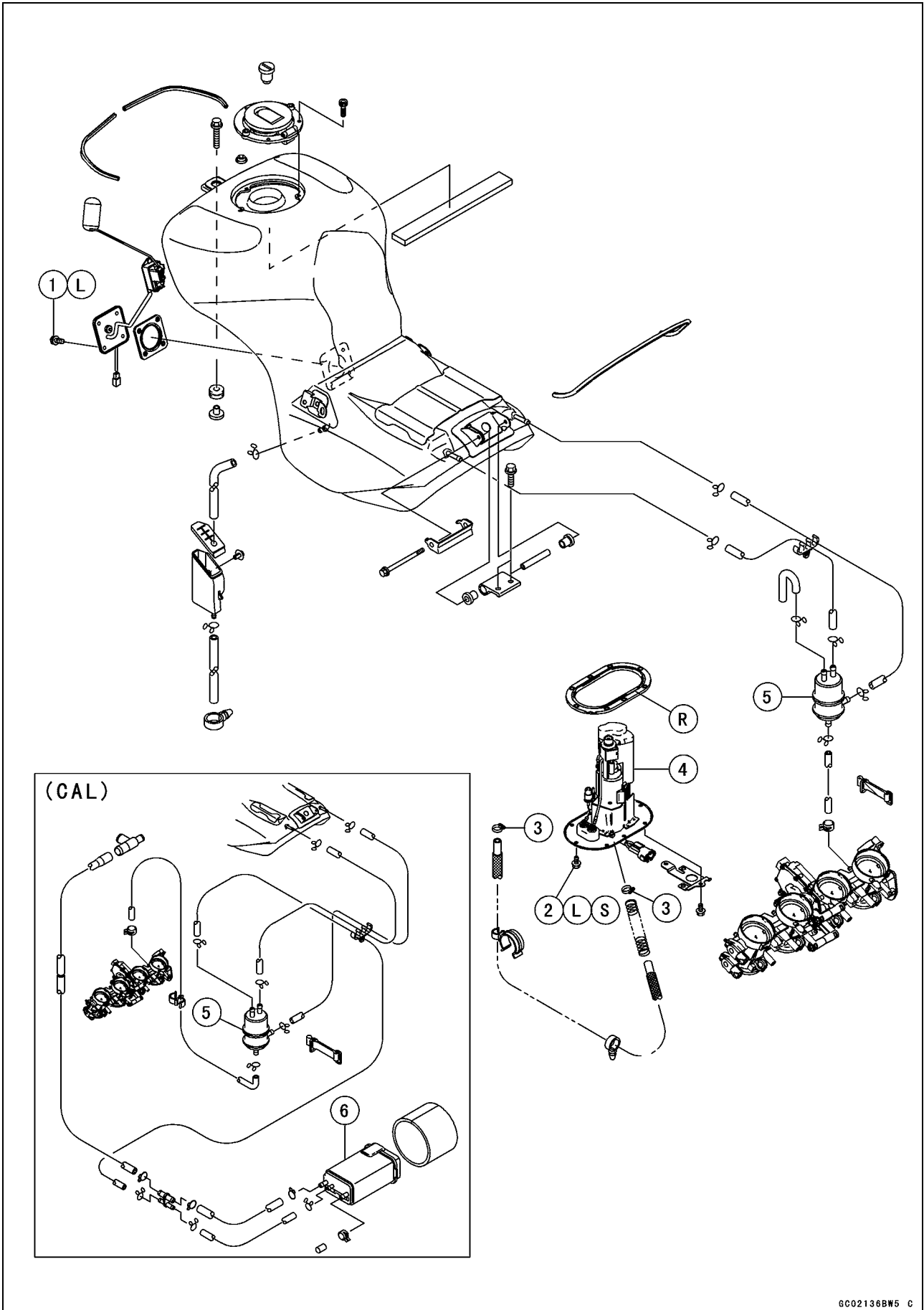

Exploded View

No.	Fastener	Torque			Remarks
		N·m	kgf·m	ft·lb	
1	Fuel Level Sensor Bolts	6.9	0.70	61 in·lb	L
2	Fuel Pump Bolts	6.9	0.70	61 in·lb	L, S
3	Fuel Hose Clamp Bolts	1.5	0.15	13 in·lb	

4. Fuel Pump

5. Separator

6. Canister

L: Apply a non-permanent locking agent.

R: Replacement Parts

S: Tighten the fasteners following the specified sequence.

CAL: California Model

3-12 FUEL SYSTEM (DFI)

Specifications

Item	Standard
Throttle Grip and Cables	
Throttle Grip Free Play	2 ~ 3 mm (0.08 ~ 0.12 in.)
Choke Cable	
Choke Cable Free Play	2 ~ 3 mm (0.08 ~ 0.12 in.)
Digital Fuel Injection System	
Idle Speed	1 000 ±50 r/min (rpm)
Throttle Assy:	
Type	Four barrel type
Bore	φ46 mm (1.8 in.)
Throttle Body Vacuum	26 ±1.333 kPa (195 ±10 mmHg)
Bypass Screws:	
ZX1200-B1/B2	— — —
ZX1200-B3	0 ~ 2 1/2 (for reference)
ECU (Electronic Control Unit):	
Make	Denso
Type	Digital memory type, with built in IC igniter, sealed with resin
Usable Engine Speed:	
ZX1200-B1/B2	100 ~ 11 870 r/min (rpm)
ZX1200-B3	100 ~ 11 840 r/min (rpm)
Fuel Pump:	
Type	In-tank pump (in fuel tank), or Wesco pump (friction pump)
Discharge	83 mL (2.8 US oz) or more/3 seconds
Fuel Pressure (High Pressure Line):	
Right after Ignition Switch ON, with Fuel Pump Running for 3 seconds	285 ~ 315 kPa (2.91 ~ 3.21 kgf/cm ² , 41 ~ 46 psi)
Throttle Sensor (ZX1200-B1/B2):	Non-adjustable, and non-removable
Input Voltage	4.75 ~ 5.25 V DC between BL/W and BR/BK leads
Output Voltage	1.07 ~ 4.61 V DC between Y/W and BR/BK leads (idle throttle opening to full throttle opening)
Resistance	4 ~ 6 kΩ
Main Throttle Sensor (ZX1200-B3):	Non-adjustable, and non-removable
Input Voltage	4.75 ~ 5.25 V DC between BL/W and BR/BK leads
Output Voltage at Idle Throttle Opening	1.06 ~ 1.10 V DC between Y/W and BR/BK leads
Output Voltage at Full Throttle Opening	4.26 ~ 4.86 V DC between Y/W and BR/BK leads
Resistance	4 ~ 6 kΩ
Sub Throttle Sensor (ZX1200-B3):	Non-adjustable, and non-removable
Input Voltage	4.75 ~ 5.25 V DC between BL/W and BR/BK leads
Output Voltage at Idle Throttle Opening	0.48 ~ 0.52 V DC between BR and BR/BK leads
Output Voltage at Full Throttle Opening	3.6 ~ 4.0 V DC between BR and BR/BK leads
Resistance	4 ~ 6 kΩ

Specifications

Item	Standard
Sub Throttle Valve Actuator (ZX1200-B3):	
Resistance	about 2 ~ 4 kΩ
Input Voltage	about 10 ~ 14 V DC
Atmospheric Pressure Sensor/Inlet Air Pressure Sensor:	
Input Voltage	4.75 ~ 5.25 V DC between BL/W and BR/BK lead
Output Voltage	3.46 ~ 3.82 V DC at standard atmospheric pressure (see this text for details)
Inlet Air Temperature Sensor:	
Resistance	657 ~ 1 003 kΩ at 0°C (32°F) 68 ~ 89 kΩ at 50°C (122°F) 11.95 ~ 14.37 kΩ at 100°C (212°F)
Output Voltage at ECU	about 2.26 ~ 2.50 V @20°C (68°F)
Water Temperature Sensor:	
Resistance	2.32 ~ 2.59 kΩ at 20°C (68°F) 0.31 ~ 0.326 kΩ at 80°C (176°F) 0.1399 ~ 0.1435 kΩ at 110°C (230°F)
Output Voltage at ECU	about 1.95 ~ 2.29 V @20°C (68°F)
Vehicle-down Sensor:	
Detection Method	Magnetic flux detection method
Detection Angle	more than 65° ±5° for each bank
Detection Time	within 0.5 ~ 1.0 seconds
Output Voltage	with the sensor tilted 60 ~ 70° or more: 3.7 ~ 4.4 V with sensor arrow mark pointed up: 0.4 ~ 1.4 V
Fuel Injectors:	
Type:	
ZX1200-B1/B2	46EIS × 4
ZX1200-B3	INP-284
Nozzle Type:	
ZX1200-B1/B2	One spray type with 4 holes
ZX1200-B3	One spray type with 12 holes
Resistance:	
ZX1200-B1/B2	about 12.5 Ω at 20°C (68°F)
ZX1200-B3	about 11.7 ~ 12.3 Ω at 20°C (68°F)
Immobilizer Amplifier:	
Antenna Resistance	about 0.6 ~ 0.9 Ω

3-14 FUEL SYSTEM (DFI)

Specifications

Special Tools - Oil Pressure Gauge: 57001-125

Carburetor Drain Plug Wrench, Hex 3: 57001-1269

Fork Oil Level Gauge: 57001-1290

Pilot Screw Adjuster, C: 57001-1292

Hand Tester: 57001-1394

Throttle Sensor Harness Adapter #2: 57001-1408

Fuel Pressure Gauge Adapter: 57001-1417

Needle Adapter Set: 57001-1457

Throttle Sensor Setting Adapter: 57001-1538

Sealant - Kawasaki Bond (Silicone Sealant): 56019-120

Throttle Grip and Cables

Free Play Inspection

- Refer to the Throttle Control System Inspection in the Periodic Maintenance chapter.

Free Play Adjustment

- Refer to the Throttle Control System Inspection in the Periodic Maintenance chapter.

Cable Installation

- Install the throttle cables in accordance with the Cable Routing section in the General Information chapter.
- Install the lower ends of the throttle cables in the cable bracket on the throttle assy after installing the upper ends of the throttle cables in the grip.
- After installation, adjust each cable properly.

⚠ WARNING

Operation with incorrectly routed or improperly adjusted cables could result in an unsafe riding condition.

Cable Lubrication

- Refer to the General Lubrication Perform in the Periodic Maintenance chapter.

3-16 FUEL SYSTEM (DFI)

Choke Cable

Free Play Inspection

- Push the choke lever [A] all the way to the front.
- Check choke cable free play [B].
- ★ If the free play is incorrect, adjust the choke cable.

Choke Cable Free Play

Standard: 2 ~ 3 mm (0.08 ~ 0.12 in.)

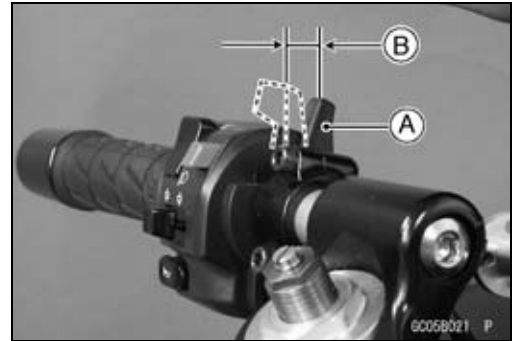

Free Play Adjustment

- Remove the right upper and lower inner cover (see Frame chapter).
- Loosen the locknut [A], and turn the adjuster [B] until the cable has the proper amount of free play.
- Tighten the locknut securely.
ZX1200-B3 [C]

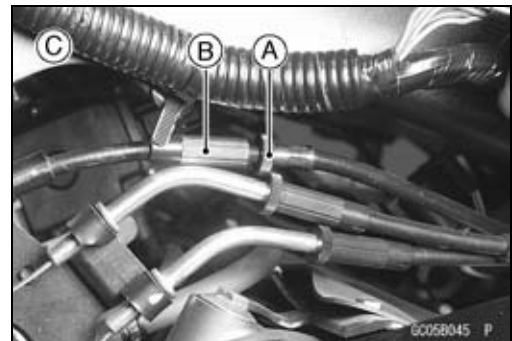
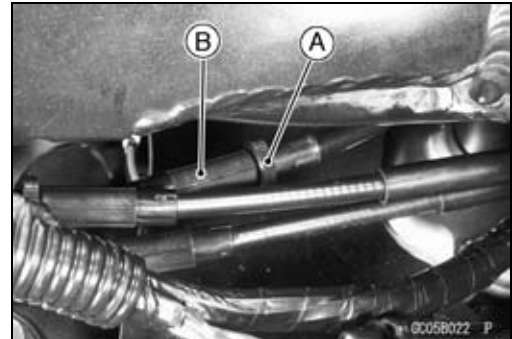

Choke Cable Installation

- Install the choke cable in accordance with the Cable Routing section in the General Information chapter.
- After installation, adjust the cable properly.

⚠ WARNING

Operation with an incorrectly routed or improperly adjusted cable could result in an unsafe riding condition.

Cable Lubrication

- Refer to the General Lubrication Perform in the Periodic Maintenance chapter.

Throttle Body Assy

Idle Speed Inspection

- Refer to the Idle Speed Inspection in the Periodic Maintenance chapter.

Throttle Bore Cleaning

- Refer to the Throttle Control System Inspection in the Periodic Maintenance chapter.

Synchronization Inspection

- Refer to the Engine Vacuum Synchronization Inspection in the Periodic Maintenance chapter.

Synchronization Adjustment

- Refer to the Engine Vacuum Synchronization Inspection in the Periodic Maintenance chapter.

Throttle Body Assy Removal

⚠ WARNING

Gasoline is extremely flammable and can be explosive under certain conditions. Turn the ignition switch OFF. Disconnect the battery (–) cable terminal. Do not smoke. Make sure the area is well-ventilated and free from any source of flame or sparks; this includes any appliance with a pilot light.

Be prepared for fuel spillage: any spilled fuel must be completely wiped up immediately.

- Remove:
 - Seats (see Frame chapter)
 - Fuel Tank Cover (see Fuel Tank Removal)
- Set up the fuel tank [A] with the supporting rod [B].

CAUTION

Do not insert the supporting rod into the bolt hole, or the thread of the bolt hole could be damaged.

- Disconnect the inlet air temperature sensor connector [A].
- Remove:
 - Air Cleaner Cap Bolts [B]
 - Right and Left Air Cleaner Caps [C]

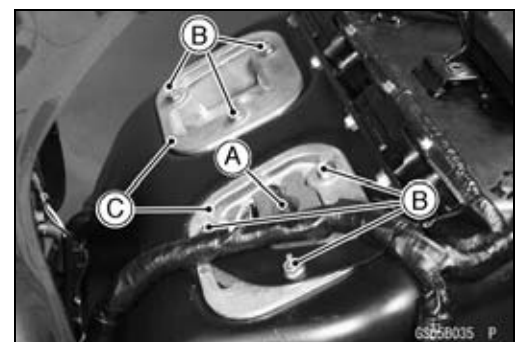
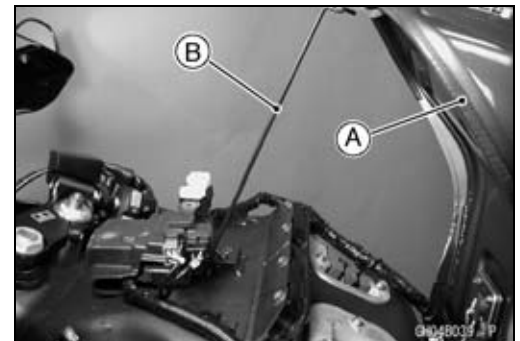

3-18 FUEL SYSTEM (DFI)

Throttle Body Assy

- Unscrew the duct bolts [A].
- Pull out the ducts [B] upward.

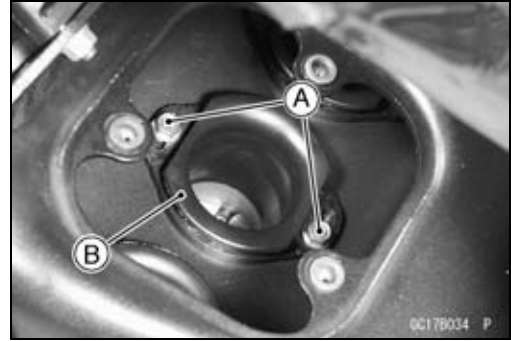

ZX1200-B1/B2

- Remove the brackets [A] from the stoppers [B].

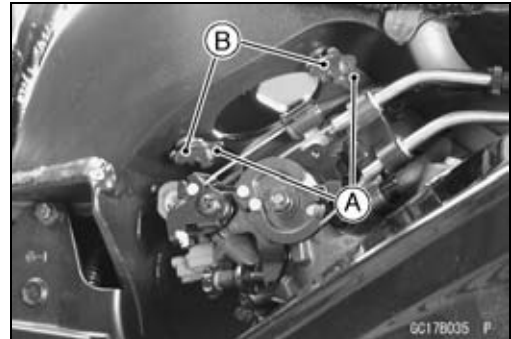

- Disconnect the throttle sensor connector [A].
- Pull out the vacuum hose [B] from the inlet air pressure sensor.

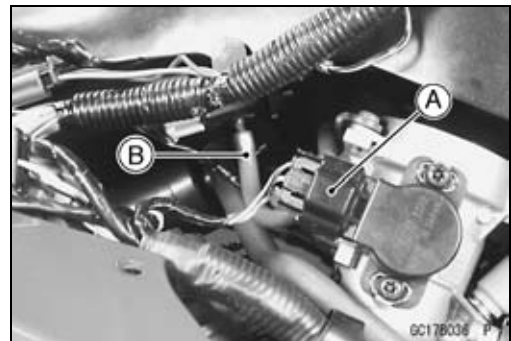

- Disconnect the injector lead connector [A].
- Loosen the holder clamp Allen bolts [B].

Special Tool - Carburetor Drain Plug Wrench, Hex 3:
57001-1269

⚠ WARNING

Fuel spilled from the fuel hoses are hazardous.

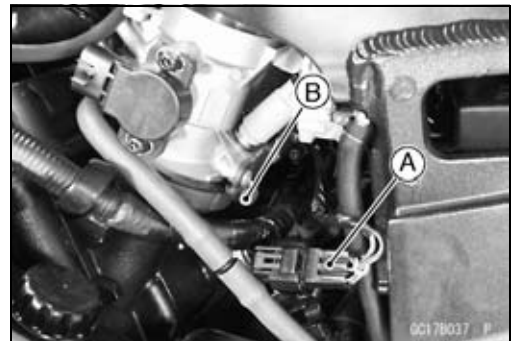

- Remove the choke cable lower end [A] with pushing the choke lever forward to make a cable slack.
- Remove the throttle case to make a throttle cable slack.
- Remove the throttle cable lower ends [B].
- Be sure to place a piece of cloth around the fuel supply hose pipe of the throttle body assy.
- Pull off the fuel hose [C].
- Plug the pipe of the throttle body quickly with a suitable plug.
- Drain the fuel in hose into a suitable container.

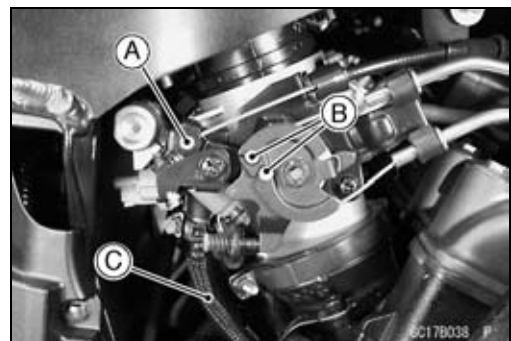

Throttle Body Assy

- Pull the throttle body assy out of the holders, and then remove it to the right side.
- Removing the throttle body assy halfway, pull out the three vacuum hoses [A] and flatten the clamp [B] to free the throttle body from the vacuum hoses.
- After removing the throttle body assy, stuff pieces of lint-free, clean cloths into the throttle body holders and wrap the air cleaner holes with the clean cloth.

CAUTION

If dirt gets into the engine, excessive engine wear and possible engine damage will occur.

ZX1200-B3

- Remove the brackets [A] from the stoppers [B].
- Disconnect the main and sub throttle sensor connectors [A].
- Pull out the vacuum hose from the inlet air pressure sensor.

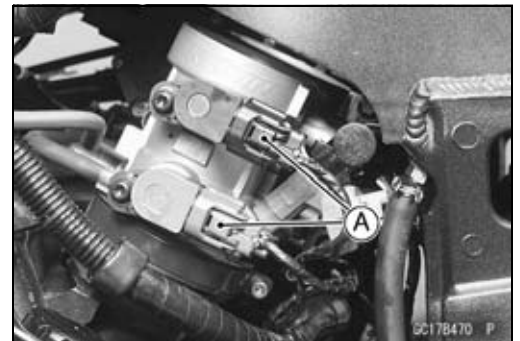
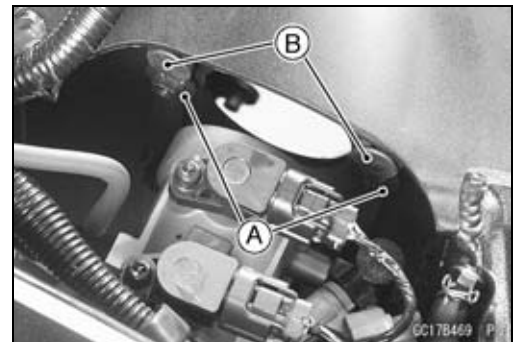
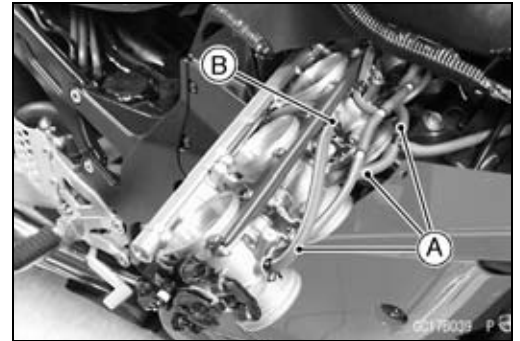

- Loosen the holder clamp Allen bolts [A].
Special Tool - Carburetor Drain Plug Wrench, Hex 3: 57001-1269

⚠ WARNING

Fuel spilled from the fuel hoses are hazardous.

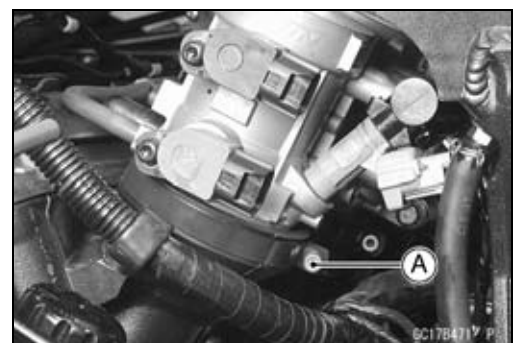

- Remove the choke cable lower end [A] with pushing the choke lever forward to make a cable slack.
- Remove the throttle case to make a throttle cable slack.
- Remove the throttle cable lower ends [B].
- Be sure to place a piece of cloth around the fuel supply hose pipe of the throttle body assy.
- Pull off the fuel hose [C].
- Plug the pipe of the throttle body quickly with a suitable plug.
- Drain the fuel in hose into a suitable container.

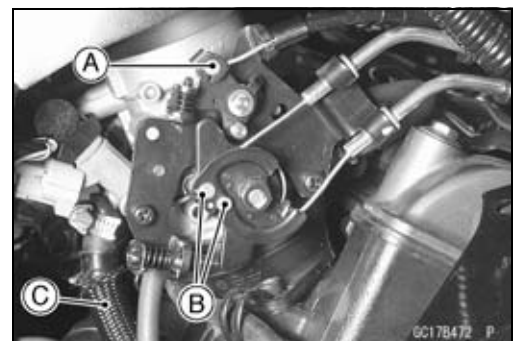

3-20 FUEL SYSTEM (DFI)

Throttle Body Assy

- Disconnect the connector [A].
- Disconnect the injector lead connector [A].
- Pull the throttle body assy out of the holders, and then remove it to the right side.
- Removing the throttle body assy halfway, flatten the clamp [A] to free the throttle body from the hose [B].
- After removing the throttle body assy, stuff pieces of lint-free, clean cloths into the throttle body holders and wrap the air cleaner holes with the clean cloth.

CAUTION

If dirt gets into the engine, excessive engine wear and possible engine damage will occur.

Throttle Body Assy Installation

ZX1200-B1/B2

- Install the holder clamps [A] aligning their projection with the holder hole, the screw heads [B] on the left side as well.
- Special Tool - Carburetor Drain Plug Wrench, Hex 3: 57001-1269**
- Run the vacuum hoses and fuel hoses as shown in the Cable, Wire, and Hose Routing section of the General Information chapter.
 - Turn the throttle grip to make sure that the throttle linkages do not contact the holder screws or hoses.

⚠ WARNING

Be sure to install the holder clamp screws in the direction shown. Or, the screws could come in contact with the throttle linkage resulting in unsafe riding condition.

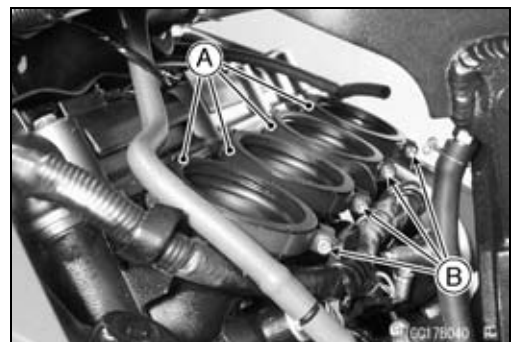
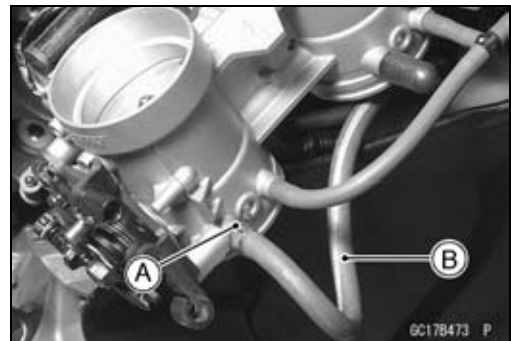
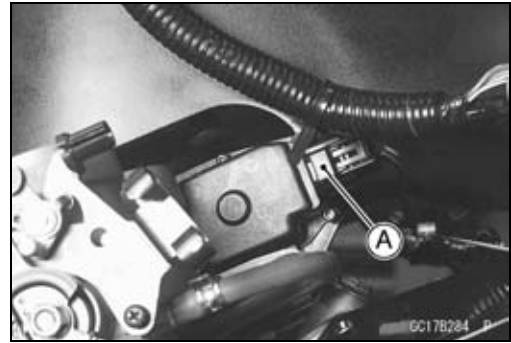

Throttle Body Assy

- Be sure the fuel hose [A] are clamped securely to prevent leaks.

⚠ WARNING

Fuel spilled from the fuel hoses are hazardous.

- Adjust:
Throttle Grip Free Play
Choke Lever Free Play
Idle Speed

ZX1200-B3

- Install the holder clamps [A] aligning their projection with the holder hole, the screw heads [B] on the left side as well.

Special Tool - Carburetor Drain Plug Wrench, Hex 3: 57001-1269

- Run the vacuum hoses and fuel hoses as shown in the Cable, Wire, and Hose Routing section of the General Information chapter.
- Turn the throttle grip to make sure that the throttle linkages do not contact the holder screws or hoses.

⚠ WARNING

Be sure to install the holder clamp screws in the direction shown. Or, the screws could come in contact with the throttle linkage resulting in unsafe riding condition.

- Be sure the fuel hose [A] are clamped securely to prevent leaks.

⚠ WARNING

Fuel spilled from the fuel hoses are hazardous.

- Adjust:
Throttle Grip Free Play
Choke Lever Free Play
Idle Speed

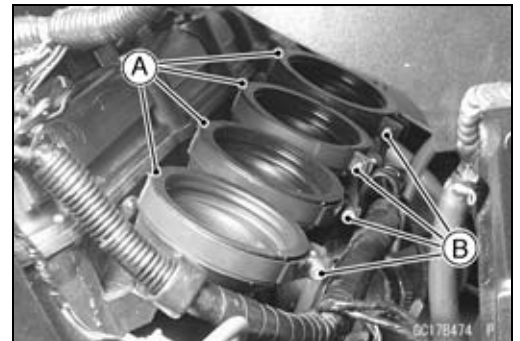
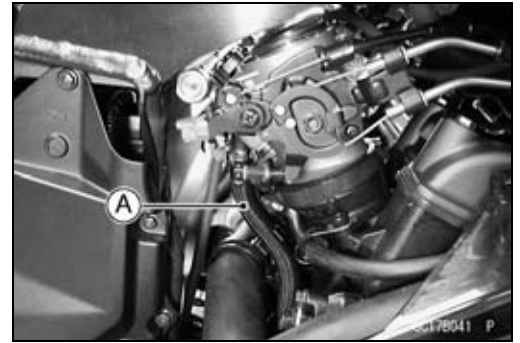

3-22 FUEL SYSTEM (DFI)

Throttle Body Assy

Throttle Body Assy Disassembly ZX1200-B1/B2

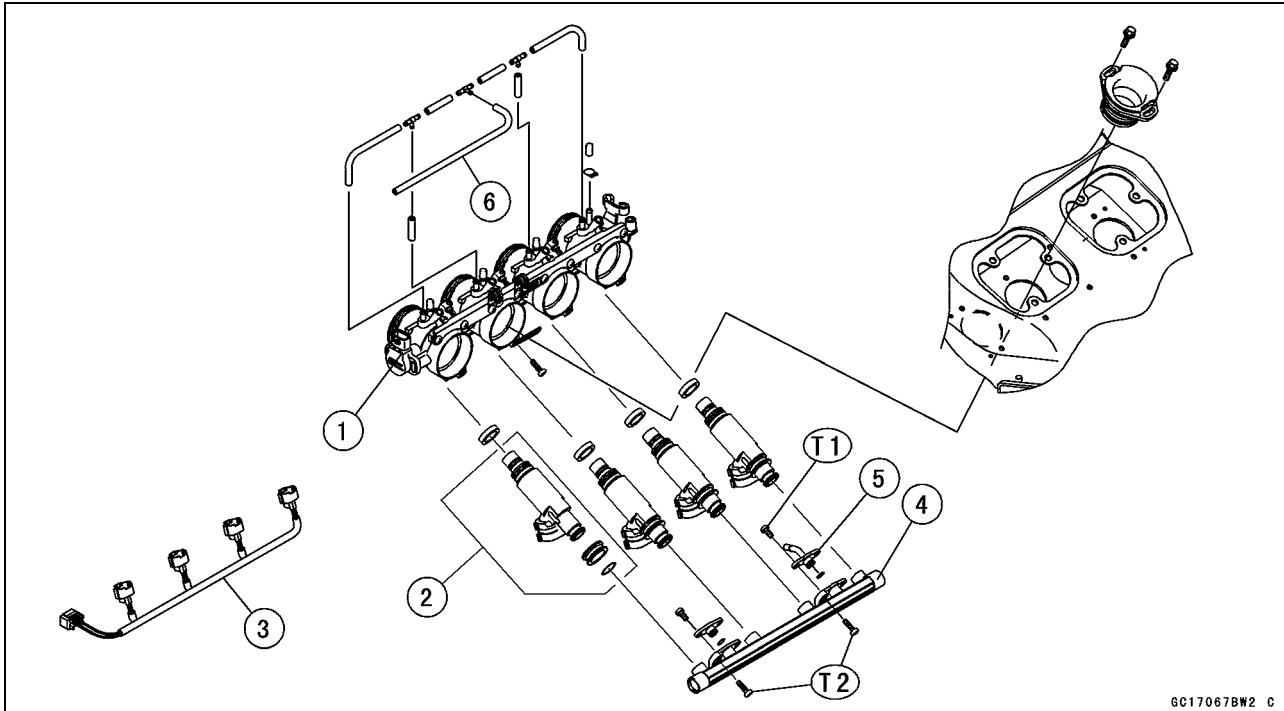

1. Throttle Body Assy

2. Injector

3. Injector Connector Assy

4. Delivery Pipe Assy

5. Nipple Assy

6. Inlet Air Pressure Sensor Hose

T1: 3.5 N·m (0.35 kgf·m, 31 in·lb)

T2: 5.0 N·m (0.50 kgf·m, 44 in·lb)

CAUTION

Do not remove, disassemble or adjust the throttle sensor, throttle link mechanism and throttle body assy, because they are adjust or set surely at the manufacturer. Adjustment of these parts could result in poor performance, requiring replacement of the throttle body assy.

- Remove the throttle body assembly (see this chapter).
- Open the clamps (4) [A] which bind the connector lead.
- Pressing the tab [C] of each injector connector [B], pull out the each connector and remove the injector connector assy [D].

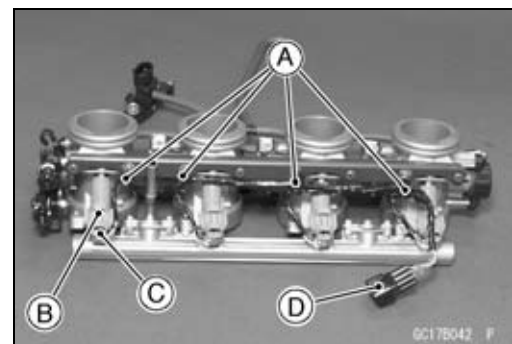

Throttle Body Assy

- Pull out the each hose [A] from the throttle body fittings, open the clamps (2) [B] which bind the hoses, and remove the hose assy.
- Remove the screws (2) [C] to pull out the injector assys (4) from the throttle body assys together with the delivery pipe [D].

NOTE

○Do not damage the part of insert of the injectors when they are pulled out from the throttle body.

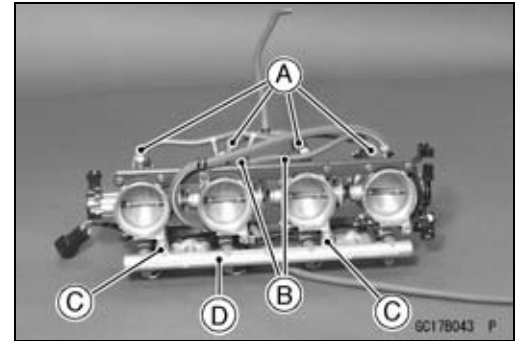

- Pull out the injector assy [A] from the delivery pipe [B].

NOTE

○Do not damage the part of insert of the injectors when they are pulled out from the delivery pipe.

- Remove the nipple assy [C].

NOTE

○Do not damage the part of insert of the nipple when it is pulled out from the delivery pipe.

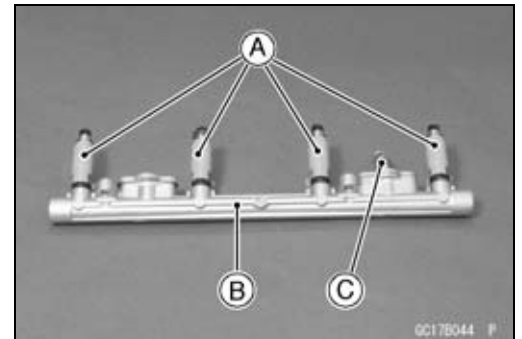

ZX1200-B3

CAUTION

Do not remove, disassemble or adjust the main throttle sensor [A], subthrottle sensor [B], subthrottle valve actuator [C], throttle link mechanism [D] and throttle body assy [E], because they are adjusted or set at the manufacturer. Adjustment of these parts could result in poor performance, requiring replacement of the throttle body assy.

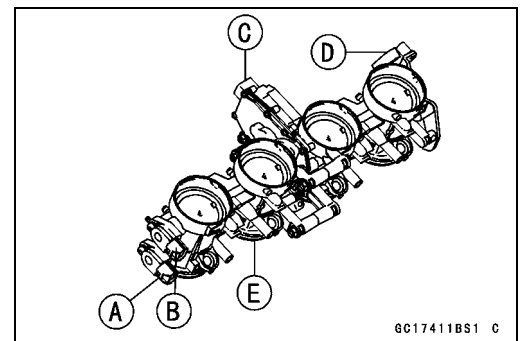

- Remove the throttle body assy (see Throttle Body Assy Removal).

CAUTION

Never drop the throttle body assy, especially on a hard surface. Such a shock to the body assy can damage it.

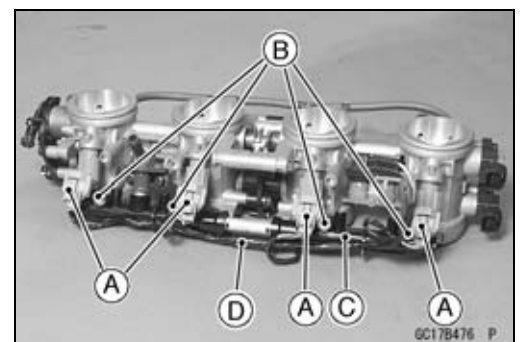

- Push the lock and disconnect the injector connectors [A].
- Remove:
 - Screws [B]
 - Delivery Pipe [C] along with harness [D] and injectors
- ★If necessary, cut straps and take the harness off the delivery pipe.

3-24 FUEL SYSTEM (DFI)

Throttle Body Assy

CAUTION

Never drop the injector, especially on a hard surface. Such a shock to the injector can damage it.

- Pull out the injectors along with the delivery pipe [A].
- ★ If necessary, remove the injectors from the delivery pipe. Replace the O-rings of the indicators.
- ★ If necessary, cut straps and take the harness off the delivery pipe.

Throttle Body Assy Assembly

ZX1200-B1/B2

- Before assembling, blow away dirt or dust from the throttle body and delivery pipe by applying compressed air.
- Apply daphne oil or engine oil to the new O-rings [B] of each injector [A], insert them to the delivery pipe assy [C] and confirm whether the injectors turn smoothly or not.

NOTE

○ Replace the O-ring of injectors and the dust seals of delivery pipe to new one.

- Apply daphne oil or engine oil to the O-rings, insert the and nipple assy [D] to the delivery pipe and tighten the screws [E] after confirming the nipple assy turn smoothly.

Torque - Regulator and Nipple Assy Screws: 3.5 N·m (0.35 kgf·m, 31 in·lb)

- Apply daphne oil or engine oil to the new dust seals [A], insert the injectors installed to the delivery pipe assy to the throttle body.

NOTE

○ Replace the dust seals of the throttle body to new one.

- Install the delivery pipe assy to the throttle body.

Torque - Delivery Pipe Screws: 5.0 N·m (0.50 kgf·m, 44 in·lb)

- Install the injector connectors to each injector, and bind the connector lead with clamps (4).

NOTE

○ Keep the clearance of 5 mm (0.20 in.) or more between the connector lead and the nipple assy when the connector leads are run.

○ Run each connector lead keeping the clearance of 2 ~ 4 mm (0.08 ~ 0.16 in.) above each connector.

- Insert the each hoses to the throttle body fittings, and bind the hose assy with the clamps (2).
- Install the throttle body assy (see Throttle Body Assy Installation).

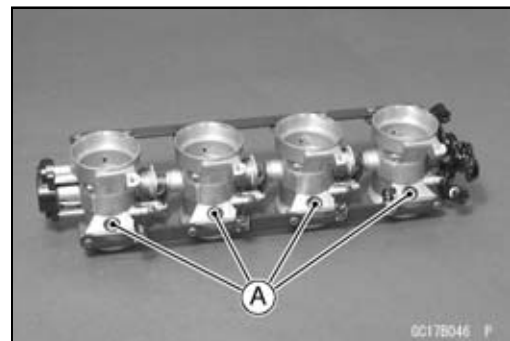
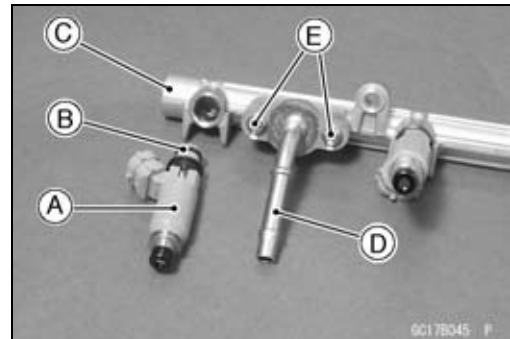
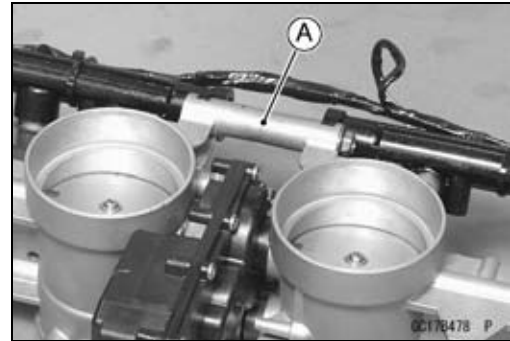

Throttle Body Assy

ZX1200-B3

- Replace the O-rings [A] with the new ones.
- Before assembling, blow away dirt or dust from the throttle body and delivery pipe by applying compressed air.
- Apply engine oil to the new O-rings of fuel pipe.
- Install the fuel pipe [B] to the delivery pipes [C].

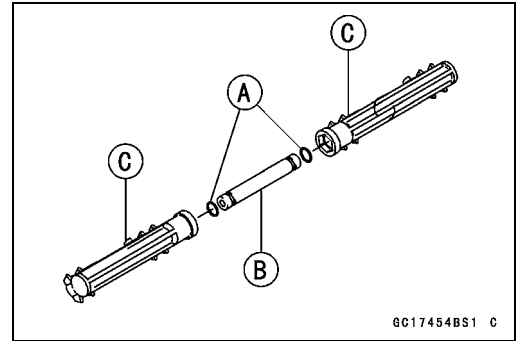

- Replace the O-rings [A] of injectors and the seals [B] with the new ones.
- Apply engine oil to the new O-rings of each injector [C], insert them into the delivery pipe [D] and confirm whether the injectors turn smoothly or not.
- Install the injectors along with the delivery pipe assy into the throttle bodies [E].

Torque - Delivery Pipe Screws: 3.4 N·m (0.35 kgf·m, 30 in·lb)

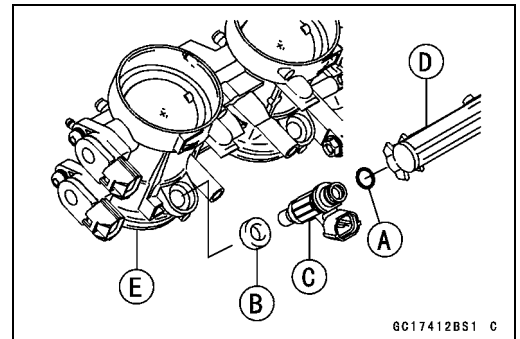

- Bind the leads with straps [A].
- Insert the each hoses onto the throttle body fittings.
- Install the throttle body assy (see Throttle Body Assy Installation).

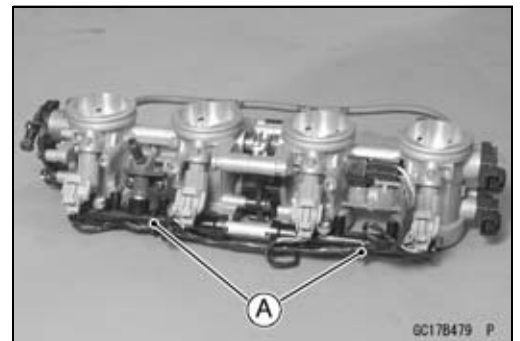

3-26 FUEL SYSTEM (DFI)

Air Line

Element Removal

- Remove:
 - Seats (see Frame chapter)
 - Fuel Tank Cover (see Fuel Tank Removal)
 - Supporting Rod (see Fuel Tank Removal)
- Set up the fuel tank [A] with the supporting rod [B].

CAUTION

Do not insert the supporting rod into the bolt hole, or the thread of the bolt hole could be damaged.

- Unscrew the nuts [A] and remove the bolts.
- Pull out the elements [B].

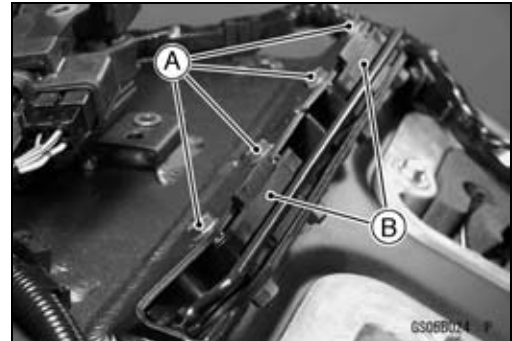
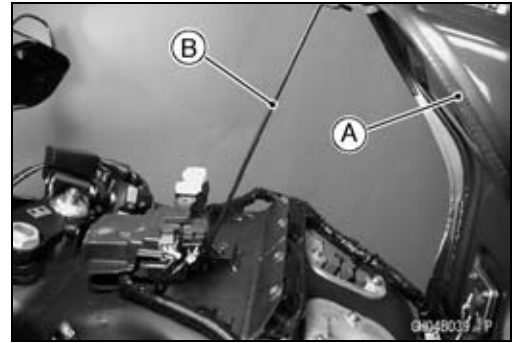

Element Installation

- Install the elements [A] with the mark side (FRONT) facing front.

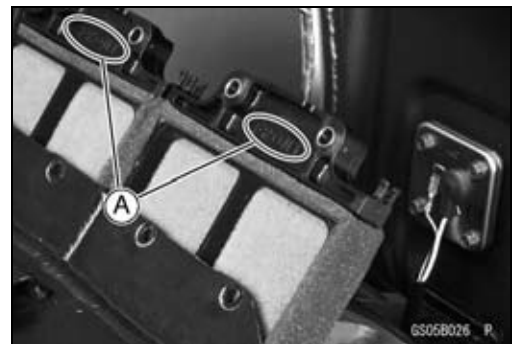

Air Cleaner Element Cleaning and Inspection

- Refer to the Air Cleaner Element Cleaning (ZX1200-B1/B2)/Element Replacement (ZX1200-B3) in the Periodic Maintenance chapter.

Oil Draining

A drain hose is connected to the bottom of the air cleaner part to drain water or oil accumulated in the cleaner part.

- Visually check the catch tank [A] of the drain hose if the water or oil accumulates in tank.
- ★ If any water or oil accumulates in the tank, drain it by taking off the drain plug [B] at the lower end of the drain hose.

⚠ WARNING

Be sure reinstall the plug in the drain hose after draining. Oil on tires will make them slippery and can cause an accident and injury.

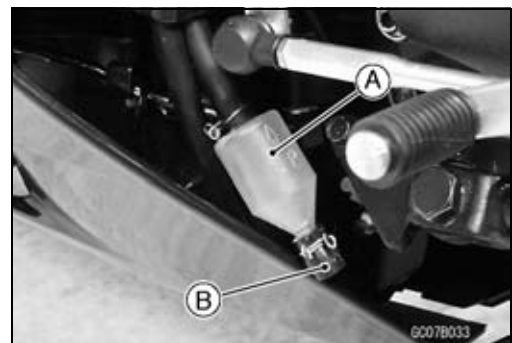

Air Line

Air Inlet Duct Removal

- Remove the lower inner cover (see Frame chapter).
- Loosen the clamp screws [A].
- Slide the frame side of the duct forward first, and remove the duct [B].

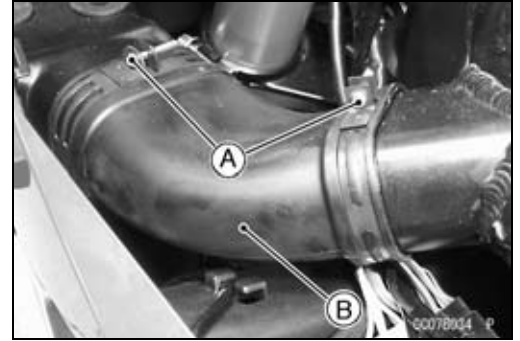

Air Inlet Duct Installation

- The left rubber duct [A] has a L mark [B] and the right rubber duct has a R mark.
- First insert the duct to the front duct and then insert the rubber duct stopped to the frame duct.
- Tighten the clamp screws securely.

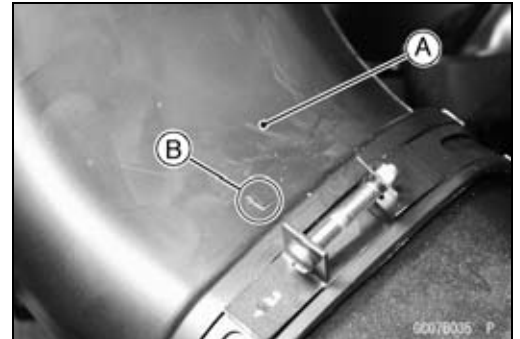

Front Duct Removal/Installation

- Refer to the Upper Fairing Disassembly/Assembly in the Frame chapter.

3-28 FUEL SYSTEM (DFI)

Fuel Tank

Fuel Tank Removal

⚠ WARNING

Gasoline is extremely flammable and can be explosive under certain conditions. Make sure the area is well-ventilated and free from any source of flame or sparks; this includes any appliance with a pilot light. Do not smoke. Turn the ignition switch OFF. Be prepared for fuel spillage; any spilled fuel must be completely wiped up immediately.

CAUTION

For California model, if gasoline, solvent, water or any other liquid enters the canister, the canister's vapor absorbing capacity is greatly reduced. If the canister does become contaminated, replace it with a new one.

- Remove:
 - Rear Seat (see Frame chapter)
 - Front Seat (see Frame chapter)
 - Allen Bolts [A]
 - Fuel Tank Cover Plate [B]

- Screws [A]
- Allen Bolts [B]
- Fuel Tank Cover [C]

- Bolt [A]

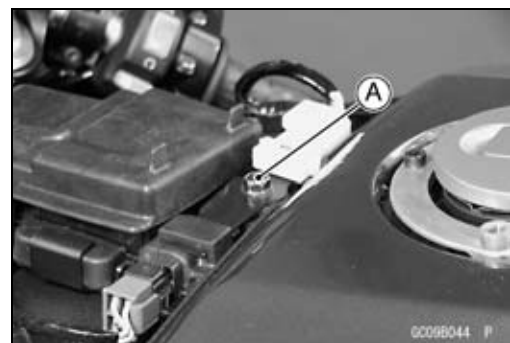
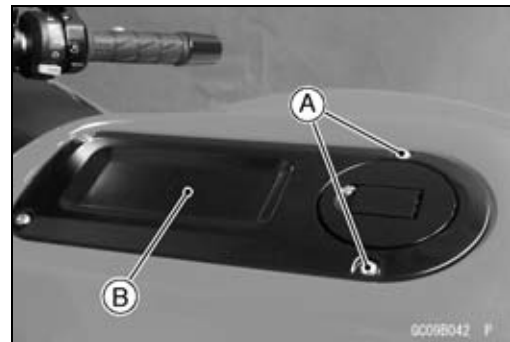

Fuel Tank

- Pull up the front portion of the fuel tank, and then, pull out the supporting rod [A].



- Lift the front portion of the fuel tank [A] and support it with the supporting rod [B].

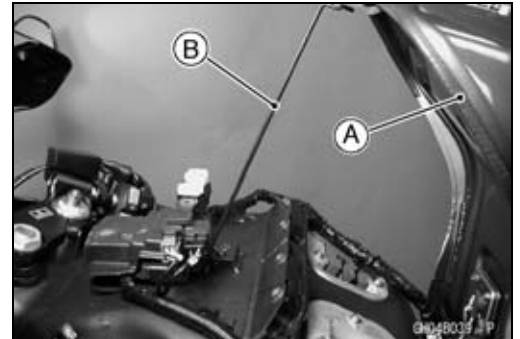

CAUTION

Do not insert the supporting rod into the bolt hole, or the thread of the bolt hole could be damaged.

- Be sure to place a piece of cloth [A] around the fuel outlet hose pipe [B] of the fuel tank.
- Loosen the clamp bolt [C] and pull out the fuel supply hose [D] from the pipe.

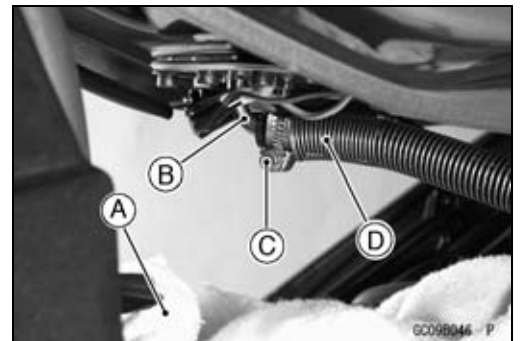

- Quickly plug the pipe with a plug [E] (a suitable air cleaner catch tank plug).
- Drain the fuel in hose into a suitable container.



⚠ WARNING

Be prepared for fuel spillage; any spilled fuel must be completely wiped up immediately. When the fuel hose is disconnected, fuel spills out from the hose and the pipe because of residual pressure. Cover the hose connection with a piece of clean cloth to prevent fuel spillage.

- Disconnect the connectors [A].

CAUTION

Do not pull the leads [B] of the fuel pump and fuel reserve switch. If they are pulled, their lead terminals may be damaged.

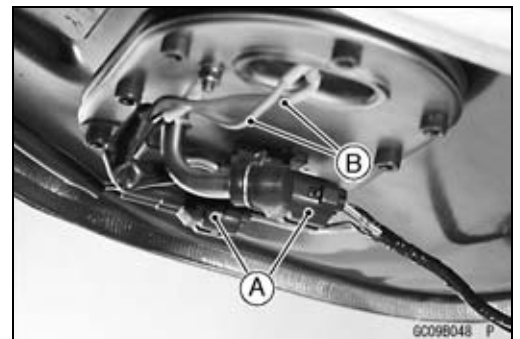

3-30 FUEL SYSTEM (DFI)

Fuel Tank

- Remove the supporting rod, and set the fuel tank to proper position.
- Remove the breather hose [A] and return hose [B].

CAUTION

The fuel tank may be damaged if its bracket bolts are removed lifting the front portion of fuel tank upward.

- Unscrew the bolts [C].
- Remove the fuel tank.

Fuel Tank Installation

- Installation is the fuel tank bracket bolts first, and then install the other parts.
- Be sure the hose is clamped securely to prevent leaks.

Torque - Fuel Hose Clamp Bolt: 1.5 N·m (0.15 kgf·m, 13 in·lb)

- Route the hoses correctly.
- Be sure to insert the drain hose [A] in the catch tank [B].

Fuel Tank Inspection

- Remove the hose(s) from the fuel tank, and open the tank cap.
- Check to see if the water drain pipe [B] and fuel breather pipe [C] in the tank are not clogged. Check the tank cap breather also.
- ★ If they are clogged, remove the tank and drain it, and then blow the breather free with compressed air.

CAUTION

Do not apply compressed air to the air vent holes [A] in the tank cap. This could cause damage and clogging of the labyrinth in the cap.

- Visually inspect the fuel pump bracket [A] and fuel level sensor [B] mounting portions for fuel leaks.
- ★ If they are fuel leaks, replace the gasket.

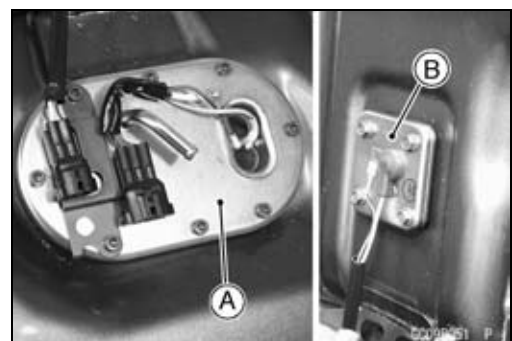
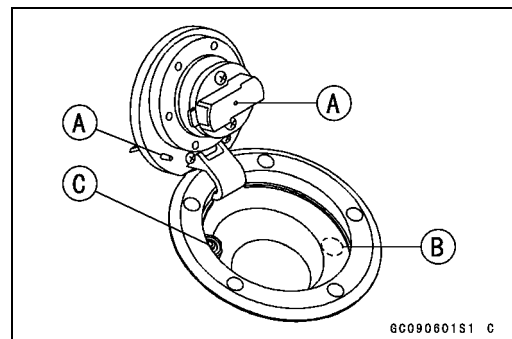
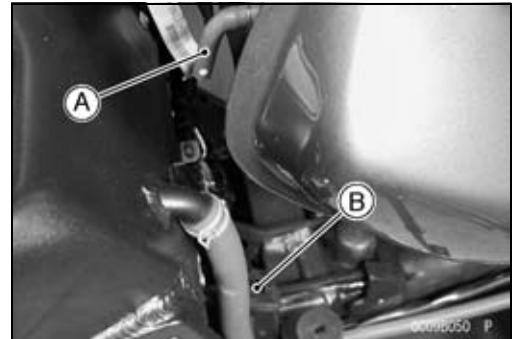
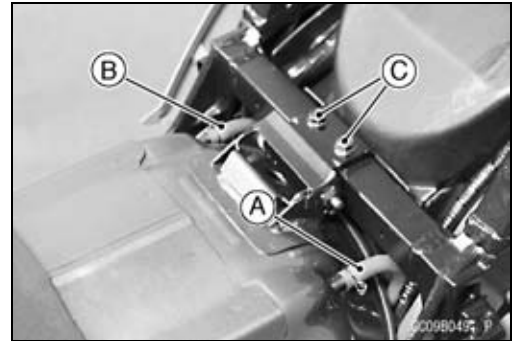

Fuel Tank

*Fuel Tank Cleaning***⚠ WARNING**

Clean the tank in a well-ventilated area, and take care that there are no sparks or flame anywhere near the working area. Because of the danger or highly flammable liquids, do not use gasoline or low flash point solvents to clean the tank.

- Remove the fuel tank (see Fuel Tank Removal).
- Drain the fuel.
- Remove the fuel pump assy and fuel level sensor.
- Pour some high flash-point solvent into the fuel tank and shake the tank to remove dirt and fuel deposits.
- Pour the solvent over of the tank.
- Dry the tank with compressed air.
- Install the fuel pump assy (see Fuel Pump Installation) and fuel level sensor (see Electrical System chapter) in the tank.
- Install the fuel tank (see Fuel Tank Installation).

3-32 FUEL SYSTEM (DFI)

DFI System

DFI System Wiring Diagram (ZX1200-B1/B2)

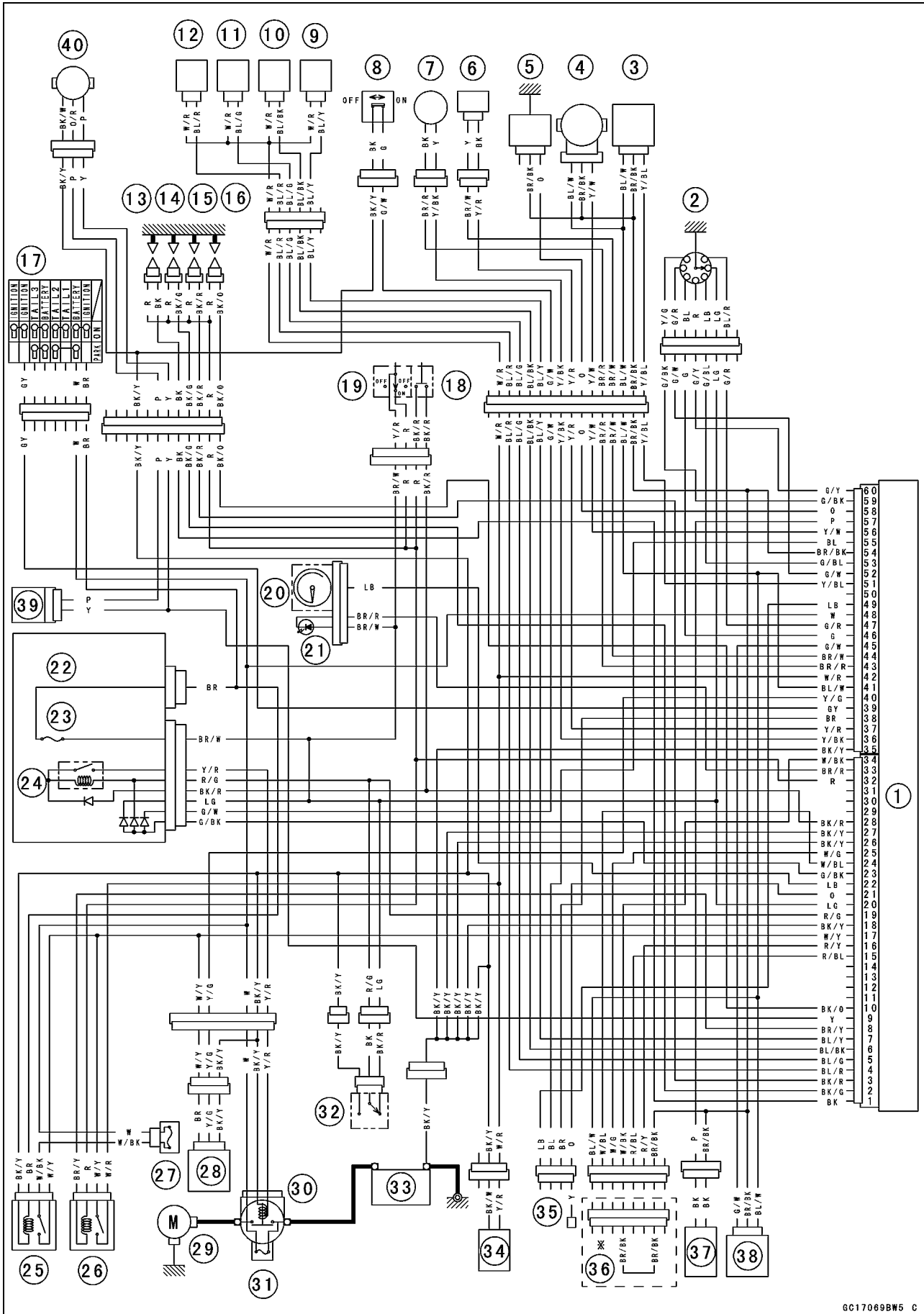

DFI System

Part Name

1. ECU (Electric Control Unit)
2. Gear Position Switch
3. Inlet Air Pressure Sensor
4. Throttle Sensor
5. Water Temperature Sensor
6. Camshaft Position Sensor
7. Crankshaft Sensor
8. Side Stand Switch
9. Injector #4
10. Injector #3
11. Injector #2
12. Injector #1
13. Stick Coil #1
14. Stick Coil #2
15. Stick Coil #3
16. Stick Coil #4
17. Ignition Switch
18. Starter Button
19. Engine Stop Switch
20. Tachometer
21. FI Indicator LED Light
22. Junction Box
23. Ignition Fuse 10 A
24. Starter Circuit Relay
25. ECU Main Relay
26. Fuel Pump Relay
27. ECU Main Fuse 15 A
28. Vehicle-down Sensor
29. Starter Motor
30. Starter Motor Relay
31. Main Fuse 30 A
32. Starter Lockout Switch
33. Battery 12 V 12 Ah
34. Fuel Pump
35. Self-diagnosis Indicator Switch
36. Open or Short Circuit Connector*

*Do not exchange the connector. To ensure optional ignition and fuel injection timing, the ECU and connector are combined.

ECU and Connector Combinations

ECU Part No.	21175-1087	21175-1089	21175-1090	21175-1091	21175-1092
Open Connector	○	○			
Short Circuit Connector			○	○	○

The part number of the ECU is in the label on the ECU.

37. Inlet Air Temperature Sensor
38. Atmospheric Pressure Sensor
39. Meter Assembly
40. Speed Sensor

3-34 FUEL SYSTEM (DFI)

DFI System

Terminal Numbers of ECU Connectors

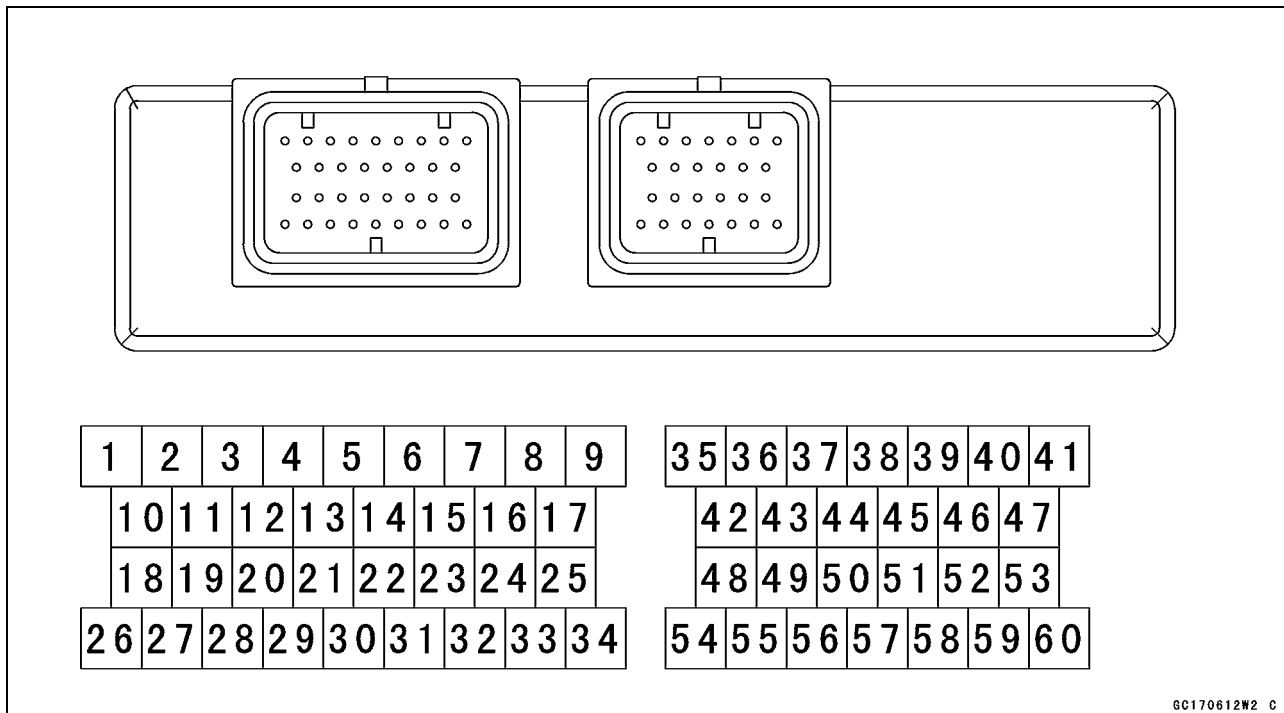

GC170612W2 C

Terminal Names

1. Stick Coil #1 Output Signal
2. Stick Coil #2 Output Signal
3. Stick Coil #3 Output Signal
4. Injector #1 Output Signal
5. Injector #2 Output Signal
6. Injector #3 Output Signal
7. Injector #4 Output Signal
8. Fuel Pump Relay Output Signal
9. Speed Sensor (SIG)
10. Stick Coil #4 Output Signal
11. Unused
12. Unused
13. Unused
14. Unused
15. Input Signal for Memory
16. Input Signal for Memory
17. Power Supply to ECU
18. Injector Power Source Circuit Ground to Battery
19. Interlock Switch Output Signal
20. Detect the Neutral Position Signal
21. Switch Displaying Diagnosis
22. Engine Speed Signal to Tachometer
23. Detect Interlock Function for Engine Stops
24. Input Signal for Memory
25. Input Signal for Memory
26. Ignition System Circuit Ground to Battery
27. Injector Power Source Circuit Ground to Battery
28. Detect the Starter Button Pushed.
29. Unused
30. Unused
31. Unused
32. Detect the Engine Stop Switch OFF
33. FI Indicator LED Light Blinking
34. Input Signal for Memory

DFI System

35. ECU Power Source Circuit Ground to Battery
36. Crankshaft Sensor (+) Output Signal
37. Camshaft Position Sensor (+) Output Signal
38. Power Source for External Diagnosis System
39. Power Supply to ECU
40. Vehicle-down Sensor Output Signal
41. Power Source to Sensor System
42. Power Supply to Injector and Fuel Pump
43. Crankshaft Sensor (-) Output Signal
44. Camshaft Position Sensor (-) Output Signal
45. Atmospheric Pressure Sensor Output Signal
46. Detect the 4th Gear Position Signal
47. Detect the 1st Gear Position Signal
48. Power Source to ECU
49. Output Signal for External Diagnosis System
50. Unused
51. Inlet Air Pressure Sensor Output Signal
52. Detect the 5th Gear Position Signal
53. Detect the 2nd Gear Position Signal
54. Sensor System Circuit Ground from ECU
55. Ground for External Diagnosis System
56. Throttle Sensor Output Signal
57. Inlet Air Temperature Sensor Output Signal
58. Water Temperature Sensor Output Signal
59. Detect the 6th Gear Position Signal
60. Detect the 3rd Gear Position Signal

3-36 FUEL SYSTEM (DFI)

DFI System

DFI System Wiring Diagram (ZX1200-B3)

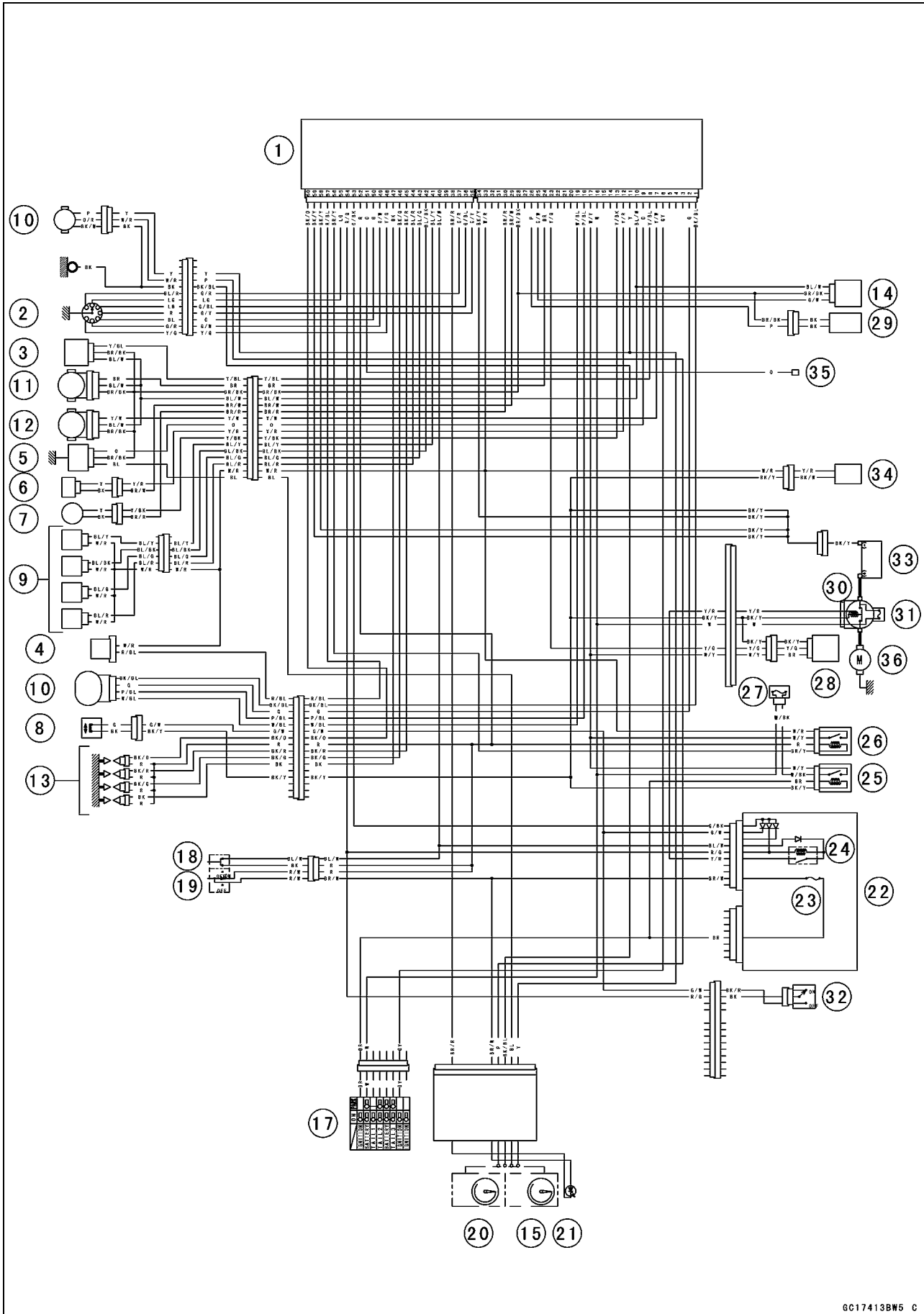

DFI System

Part Name

1. ECU (Electric Control Unit)
2. Gear Position Switch
3. Inlet Air Pressure Sensor
4. Air Switching Valve
5. Water Temperature Sensor
6. Camshaft Position Sensor
7. Crankshaft Sensor
8. Side Stand Switch
9. Injector #1, #2, #3, #4
10. Subthrottle Valve Actuator
11. Subthrottle Sensor
12. Main Throttle Sensor
13. Stick Coil #1, #2, #3, #4
14. Atmospheric Pressure Sensor
15. Meter Assembly
16. Speed Sensor
17. Ignition Switch
18. Starter Button
19. Engine Stop Switch
20. Tachometer
21. FI Indicator LED Light
22. Junction Box
23. Ignition Fuse 10 A
24. Starter Circuit Relay
25. ECU Main Relay
26. Fuel Pump Relay
27. ECU Main Fuse 15 A
28. Vehicle-down Sensor
29. Inlet Air Temperature Sensor
30. Starter Relay
31. Main Fuse 30 A
32. Starter Lockout Switch
33. Battery 12 V 12 Ah
34. Fuel Pump
35. Self-diagnosis Terminal
36. Starter Motor

3-38 FUEL SYSTEM (DFI)

DFI System

Terminal Numbers of ECU Connectors

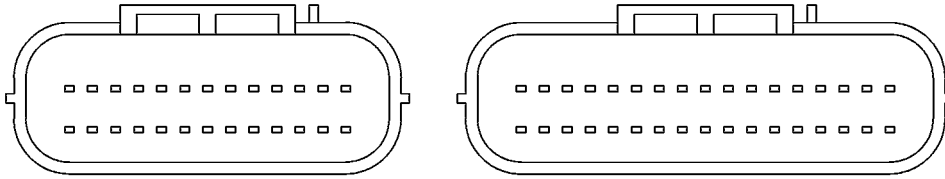

47	46	45	44	43	42	41	40	39	38	37	36	35
60	59	58	57	56	55	54	53	52	51	50	49	48

17	16	15	14	13	12	11	10	9	8	7	6	5	4	3	2	1
34	33	32	31	30	29	28	27	26	25	24	23	22	21	20	19	18

GC17414BW2 C

1. Subthrottle Valve Actuator Drive Signal
2. Subthrottle Valve Actuator Drive Signal
3. Unused
4. Unused
5. Unused
6. Ignition Switch Signal
7. Main Throttle Sensor Signal
8. Inlet Air Pressure Sensor Signal
9. Water Temperature Sensor Signal (+)
10. Power Supply to Sensors
11. Speed Sensor Signal
12. Camshaft Position Sensor Signal (+)
13. Crankshaft Sensor Signal (+)
14. Immobilizer Communication Line
15. Immobilizer Communication Line
16. Battery Power ON-OFF Signal
17. Power Supply to ECU, Injectors, and Fuel Pump
18. Subthrottle Valve Actuator Drive Signal
19. Subthrottle Valve Actuator Drive Signal
20. Unused
21. Unused
22. Unused
23. Vehicle-down Sensor Signal
24. Subthrottle Sensor Signal
25. Atmospheric Pressure Sensor Signal
26. Inlet Air Temperature Sensor Signal (+)
27. Unused
28. Ground to Sensors
29. Camshaft Position Sensor Signal (-)
30. Crankshaft Sensor Signal (-)
31. Immobilizer Communication Line
32. External Diagnosis System Signal
33. Power Supply to Injector and Fuel Pump
34. ECU Power Source Circuit Ground to Battery (-) Terminal
35. Detect the 3rd Gear Position Signal

DFI System

36. Detect the 2nd Gear Position Signal
37. Detect the 1st Gear Position Signal
38. FI Indicator LED Light Signal
39. Tachometer Signal
40. Electric Starter Button Signal
41. Injector #4 Signal
42. Injector #3 Signal
43. Injector #2 Signal
44. Injector #1 Signal
45. Stick Coil #3 Signal
46. Stick Coil #2 Signal
47. Stick Coil #1 Signal
48. Detect the 6th Gear Position Signal
49. Detect the 5th Gear Position Signal
50. Detect the 4th Gear Position Signal
51. Self-diagnosis Signal (Generated by grounding this terminal and shown by FI indicator LED light)
52. Engine Stop Switch Signal
53. Interlock Circuit Signal
54. Starter Lockout Switch Signal
55. Neutral Switch Signal
56. Fuel Pump Relay Signal
57. Air Switching Valve Signal
58. DFI System Ground
59. Ignition System Ground
60. Stick Coil #4 Signal

3-40 FUEL SYSTEM (DFI)

DFI Servicing Precautions

There are a number of important precautions that should be followed servicing the DFI system.

- This DFI system is designed to be used with a 12 V battery as its power source. Do not use any other battery except for a 12 V battery as a power source.
- Do not reverse the battery cable connections. This will damage the ECU.
- To prevent damage to the DFI parts, do not disconnect the battery cables or any other electrical connections when the ignition SW (switch) is on, or while the engine is running.
- Take care not to short the leads that are directly connected to the battery positive (+) terminal to the chassis ground.
- When charging, remove the battery from the motorcycle. This is to prevent ECU damage by excessive voltage.
- Whenever the DFI electrical connections are to be disconnected, first turn off the ignition SW (switch). Conversely, make sure that all the DFI electrical connections are firmly reconnected before starting the engine.
- Do not turn the ignition SW ON while any of the DFI electrical connectors are disconnected. The ECU memorizes service codes.
- Do not spray water on the electrical parts, DFI parts, connectors, leads, and wiring.
- If a transceiver is installed on the motorcycle, make sure that the operation of the DFI system is not influenced by electric wave radiated from the antenna. Check operation of the system with the engine at idle. Locate the antenna as far as possible away from the ECU.
- When any fuel hose is disconnected, do not turn on the ignition SW. Otherwise, the fuel pump will operate and fuel will spout from the fuel hose.
- Do not operate the in-tank fuel pump if the pump is completely dry. This is to prevent pump seizure.
- Before removing the fuel system parts, blow the outer surfaces of these parts clean with compressed air.
- When any fuel hose is disconnected, fuel may spout out by residual pressure in the fuel line. Cover the hose joint with a piece of clean cloth to prevent fuel spillage.
- When installing the fuel hoses, avoid sharp bending, kinking, flattening or twisting, and route the fuel hoses with a minimum of bending so that the fuel flow will not be obstructed.
- Route the hoses according to Cable, Wire, and Hose Routing section in the General Information chapter.

DFI Servicing Precautions

- Install the hose clamps in the position shown, and securely tighten the clamp bolts to the specified torque. Check the fuel system for leaks after hose installation.

Fuel Hose [A]

Clamp [B]

Fuel Pipe [C]

Torque - Fuel Hose Clamp Bolts: 1.5 N·m (0.15 kgf·m, 13 in·lb)

- To prevent corrosion and deposits in the fuel system, do not add to fuel any fuel antifreeze chemicals.
- Replace the fuel hose if it has been sharply bent or kinked.

- The fuel hoses are designed to be used through out the motorcycle's life without any maintenance, however, if the motorcycle is not properly handled, the high pressure inside the fuel line can cause fuel to leak [A] or the hose to burst. Bend and twist the fuel hose while examining it.

- ★ Replace the hose if any cracks [B] or bulges [C] are noticed.

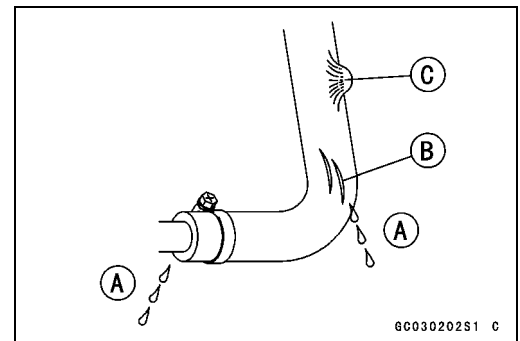
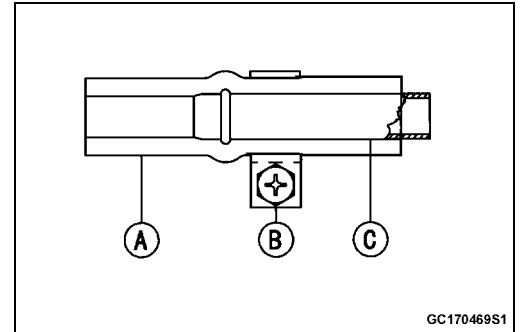

- To maintain the correct fuel/air mixture (F/A), there must be no inlet air leaks in the DFI system. Be sure to install the oil filler plug [A] after filling the engine oil.

Clutch Cover [B]

Torque - Oil Filler Plug: 1.5 N·m (0.15 kgf·m, 13 in·lb)

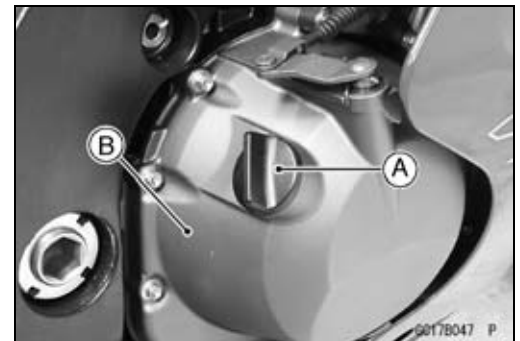

3-42 FUEL SYSTEM (DFI)

Troubleshooting the DFI System

Outline

When an abnormality in the system occurs, the FI indicator LED (Light Emitting Diode) light goes on to alert the rider on the meter panel. In addition, the condition of the problem is stored in the memory of the ECU (electronic control unit). With the engine stopped and turned in the self-diagnosis mode, the service code [A] is indicated by the number of times the FI indicator LED light blinks.

When due to a malfunction, the FI indicator LED light remains lit, ask the rider about the conditions [B] under which the problem occurred and try to determine the cause [C]. Don't rely solely on the DFI self-diagnosis function, use common sense; first conduct a pre-diagnosis inspection, check the ECU for ground and power supply, the fuel line for no fuel leaks, and for correct pressure. The pre-diagnosis items are not indicated by the FI indicator LED light.

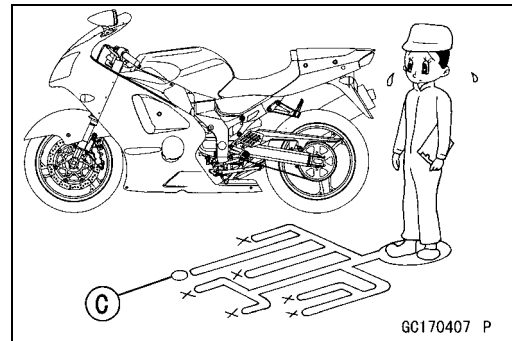
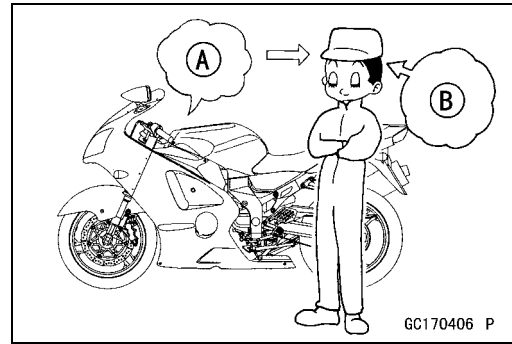

Even when the DFI system is operating normally, the FI indicator LED light [A] may light up under strong electrical interference. No remedy needed. Turn the ignition SW (switch) OFF to stop the indicator light.

When the FI indicator LED light goes on and the motorcycle is brought in for repair, check the service codes.

When the repair has been done, the LED light doesn't go on. But the service codes stored in memory are not erased to preserve the problem history, and the LED light can display the codes in the self-diagnosis mode. The problem history is referred when solving unstable problems.



Much of the DFI system troubleshooting work consists of confirming continuity of the wiring. The DFI parts are assembled and adjusted with precision, and it is impossible to disassemble or repair them.

- When checking the DFI parts, use a digital meter which can be read two decimal place voltage or resistance.

○ Remove:

Seats (see Frame chapter)

Strage Box (see Frame chapter)

- The DFI part connectors have seals, including the ECU. When measuring the input or output voltage with the connector joined, use the needle adapter set. Insert the needle adapter inside the seal until the needle adapter reaches the terminal (for example, ECU is shown.).

Digital Meter [A]

Connector [B]

Needle Adapter Set [C]

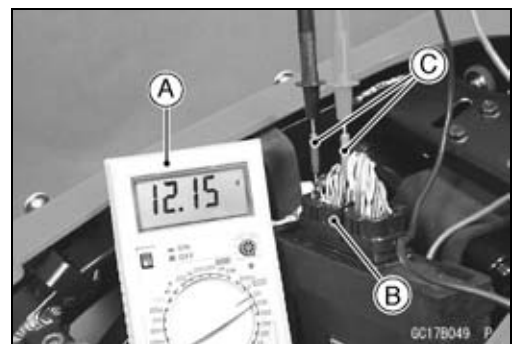

Special Tool - Needle Adapter Set: 57001-1457

CAUTION

Tape the leads to prevent short circuit of the leads.

Troubleshooting the DFI System

○After measurement, remove the needle adapters and apply silicone sealant to the seals [A] of the connector [B] for waterproofing.

Silicone Sealant (Kawasaki Bond: 56019-120) - Seals of Connector

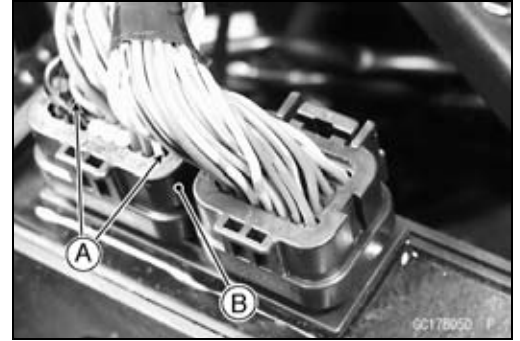

- Always check battery condition before replacing the DFI parts. A fully charged battery is a must for conducting accurate tests of the DFI system.
- Trouble may involve one or in some cases all items. Never replace a defective part without determining what CAUSED the problem. If the problem was caused by some other item or items, they too must be repaired or replaced, or the new replacement part will soon fail again
- Measure coil winding resistance when the DFI part is cold (at room temperature)
- Do not adjust or remove the throttle sensor.
- Do not directly connect a 12 V battery to a fuel injector. Insert a resistor (5 ~ 7 Ω) or a bulb (12 V \times 3 ~ 3.4 W) in series between the battery and the injector.
- The DFI parts have been adjusted and set with precision. Therefore, they should be handled carefully, never strike sharply, as with a hammer, or allowed to drop on a hard surface. Such a shock to the parts can damage them.
- Check wiring and connections from the ECU connector to the suspected faulty DFI parts, using the hand tester (special tool, analog tester) rather than a digital tester.

Special Tool - Hand Tester: 57001-1394

- Make sure all connectors in the circuit are clean and tight, and examine wires for signs of burning, fraying, etc. Deteriorated leads and bad connections can cause reappearance of problems and unstable operation of the DFI system.
- ★If any wiring is deteriorated, replace the wiring.

3-44 FUEL SYSTEM (DFI)

Troubleshooting the DFI System

- Pull each connector [A] apart and inspect it for corrosion, dirt, and damage.
- ★ If the connector is corroded or dirty, clean it carefully. If it is damaged, replace it. Connect the connectors securely.
- Check the wiring for continuity.
- Use the wiring diagram to find the ends of the lead which is suspected of being a problem.
- Connect the hand tester between the ends of the leads.
- Set the tester to the $\times 1 \Omega$ range, and read the tester.
- ★ If the tester does not read 0Ω , the lead is defective. Replace the lead or the main harness or the sub harness.

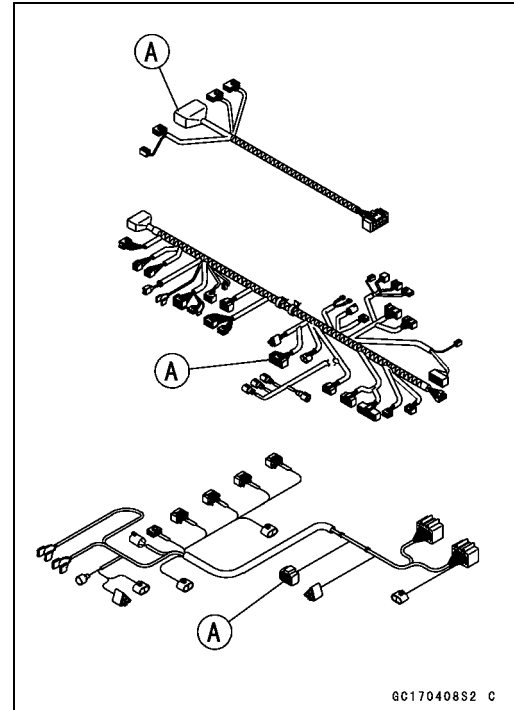

- If both ends of a harness [A] are far apart, ground [B] the one end [C], using a jumper lead [D] and check the continuity between the end [E] and the ground [F]. This enables to check a long harness for continuity. If the harness is open, repair or replace the harness.

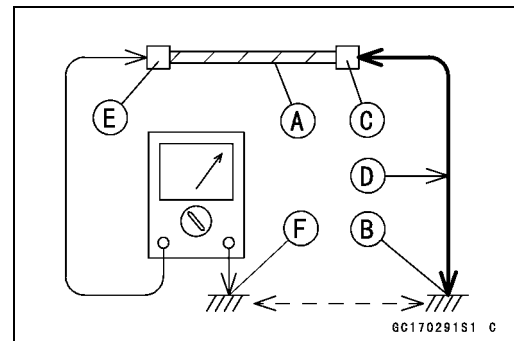

- When checking a harness [A] for short circuit, open one end [B] and check the continuity between the other end [C] and ground [D]. If there is continuity, the harness has a short circuit to ground, and it must be repaired or replaced.

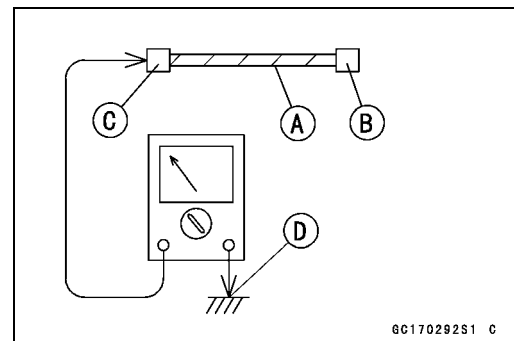

Troubleshooting the DFI System

- Narrow down suspicious locations by repeating the continuity tests from the ECU connectors.
- ★ If no abnormality is found in the wiring or connectors, the DFI parts are the next likely suspects. Check the part, starting with input and output voltages. However, there is no way to check the ECU itself.
- ★ If an abnormality is found, replace the affected DFI part.
- ★ If no abnormality is found in the wiring, connectors, and DFI parts, replace the ECU.
- The diagnosis flow chart illustrates the above procedures.
- After inspection, be sure to connect all the DFI electrical connectors. Do not turn the ignition SW ON while the DFI electrical connectors and ignition system connectors are disconnected. Otherwise, the ECU memorizes service codes as open circuit.

○ Lead Color Codes:

BK: Black	G: Green	P: Pink
BL: Blue	GY: Gray	PU: Purple
BR: Brown	LB: Light blue	R: Red
CH: Chocolate	LG: Light green	W: White
DG: Dark green	O: Orange	Y: Yellow

○ Electrical Connectors:

Female Connectors [A]

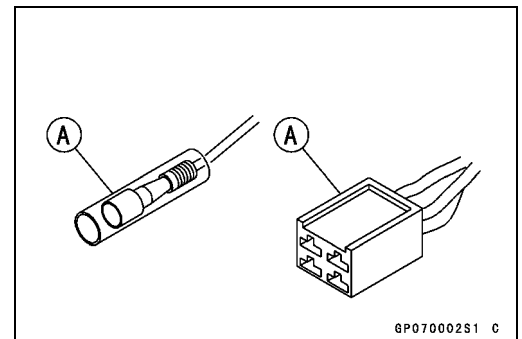

Male Connectors [B]

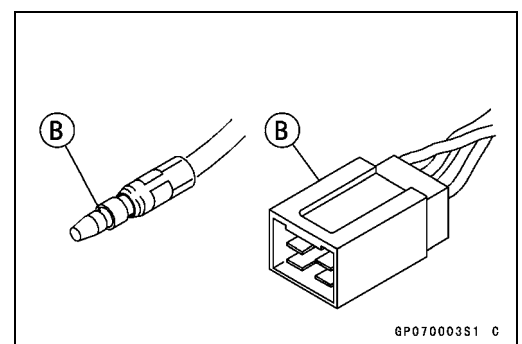

3-46 FUEL SYSTEM (DFI)

Troubleshooting the DFI System

DFI Diagnosis Flow Chart

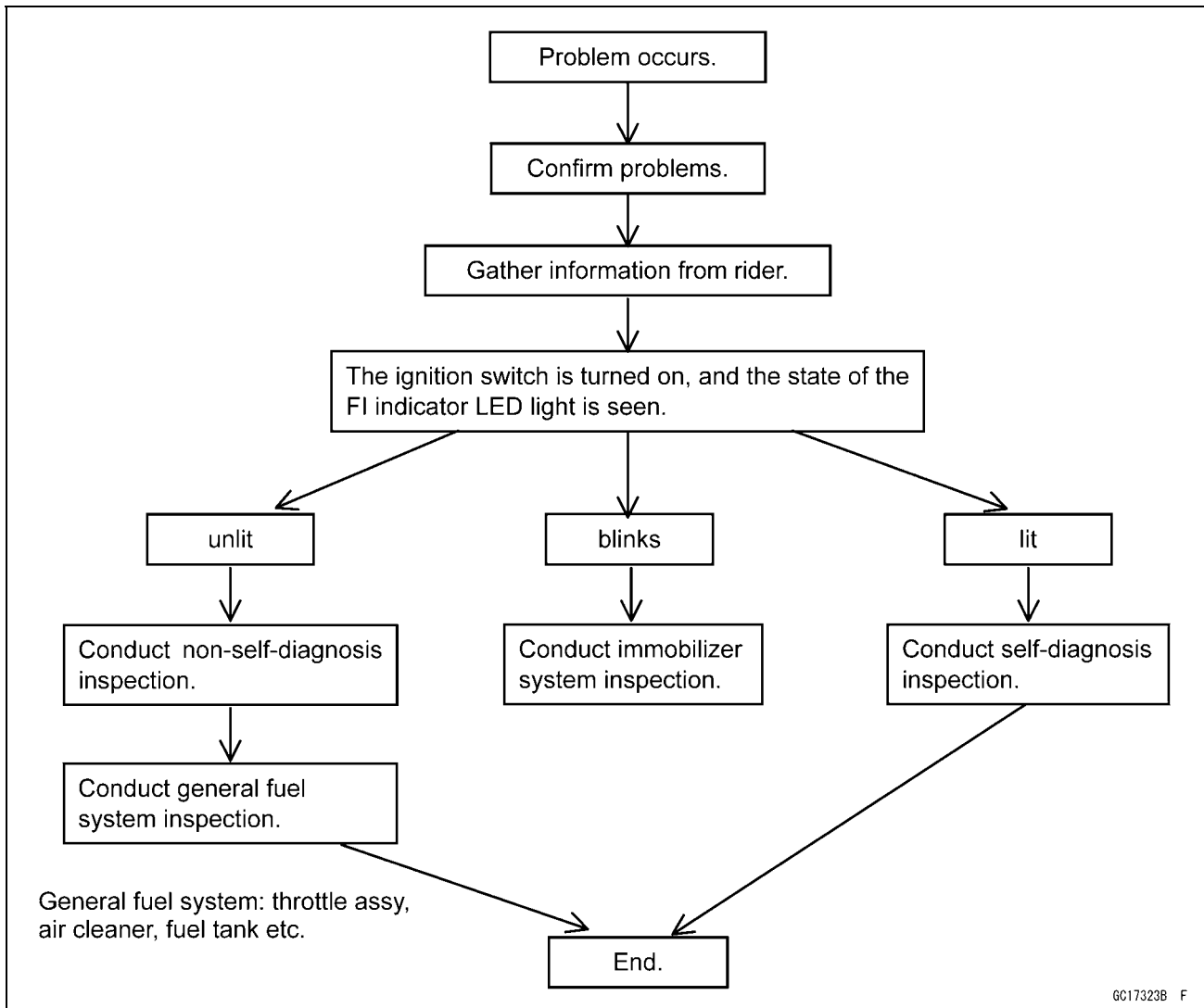

Inquiries to Rider

- Each rider reacts to problems in different ways, so it is important to confirm what kind of symptoms the rider has encountered.
- Try to find out exactly what problem occurred under exactly what conditions by asking the rider; knowing this information may help you reproduce the problem.
- The diagnosis sheet will help prevent you from overlooking any areas, and will help you decide if it is a DFI system problem, or a general engine problem.

Troubleshooting the DFI System

Sample Diagnosis Sheet

Rider Name:		Registration No. (License Plate No.):	
Year of Initial Registration:		Model:	
Engine No.:		Frame No.:	
Date Problem Occurred:		Mileage:	
Environment when problem occurred.			
Weather	<input type="checkbox"/> fine, <input type="checkbox"/> cloudy, <input type="checkbox"/> rain, <input type="checkbox"/> snow, <input type="checkbox"/> always, <input type="checkbox"/> other:		
Temperature	<input type="checkbox"/> hot, <input type="checkbox"/> warm, <input type="checkbox"/> cold, <input type="checkbox"/> very cold, <input type="checkbox"/> always		
Problem Frequency	<input type="checkbox"/> chronic, <input type="checkbox"/> often, <input type="checkbox"/> once		
Road	<input type="checkbox"/> street, <input type="checkbox"/> highway, <input type="checkbox"/> mountain road (<input type="checkbox"/> uphill, <input type="checkbox"/> downhill), <input type="checkbox"/> bumpy, <input type="checkbox"/> pebble		
Altitude	<input type="checkbox"/> normal, <input type="checkbox"/> high (about 1 000 m or more)		
Motorcycle conditions when problem occurred.			
FI Indicator LED Light	<input type="checkbox"/> light up immediately after ignition SW ON, and goes off after 1 ~ 2 seconds (normal).		
	<input type="checkbox"/> lights blinks immediately after ignition SW ON, and stays on (DFI problem)		
	<input type="checkbox"/> lights up immediately after ignition SW ON, but goes off after about 10 seconds (DFI problem).		
	<input type="checkbox"/> unlights (LED light, ECU or its wiring fault).		
	<input type="checkbox"/> sometimes lights up (probably wiring fault).		
Starting Difficulty	<input type="checkbox"/> starter motor not rotating.		
	<input type="checkbox"/> starter motor rotating but engine doesn't turn over.		
	<input type="checkbox"/> starter motor and engine don't turn over.		
	<input type="checkbox"/> no fuel flow (<input type="checkbox"/> no fuel in tank, <input type="checkbox"/> no fuel pump sound).		
	<input type="checkbox"/> engine flooded (do not crank engine with throttle opened, which promotes engine flooding).		
	<input type="checkbox"/> no spark.		
	<input type="checkbox"/> choke lever is not pulled fully when using the lever (pull it fully when using).		
<input type="checkbox"/> other:			
Engine Stalls	<input type="checkbox"/> right after starting.		
	<input type="checkbox"/> when opening throttle grip.		
	<input type="checkbox"/> when closing throttle grip.		
	<input type="checkbox"/> when moving off.		
	<input type="checkbox"/> when stopping the motorcycle.		
	<input type="checkbox"/> when cruising.		
	<input type="checkbox"/> other:		
Poor Running at Low Speed	<input type="checkbox"/> choke lever pulled out fully (push it in fully).		
	<input type="checkbox"/> very low choke speed.		
	<input type="checkbox"/> very low idle speed, <input type="checkbox"/> very high idle speed, <input type="checkbox"/> rough idle speed.		
	<input type="checkbox"/> battery voltage is low (charge the battery).		
	<input type="checkbox"/> spark plug loose (tighten it).		
	<input type="checkbox"/> spark plug dirty, broken, or gap maladjusted (remedy it).		
	<input type="checkbox"/> backfiring.		
<input type="checkbox"/> after firing.			

3-48 FUEL SYSTEM (DFI)

Troubleshooting the DFI System

	<input type="checkbox"/> hesitation when acceleration.
	<input type="checkbox"/> engine oil viscosity too high.
	<input type="checkbox"/> brake dragging.
	<input type="checkbox"/> engine overheating.
	<input type="checkbox"/> clutch slipping.
	<input type="checkbox"/> other:
Poor Running or No Power at High Speed	<input type="checkbox"/> choke lever pulled out fully (push it in fully).
	<input type="checkbox"/> spark plug loose (tighten it).
	<input type="checkbox"/> spark plug dirty, broken, or gap maladjusted (remedy it).
	<input type="checkbox"/> spark plug incorrect (replace it).
	<input type="checkbox"/> knocking (fuel poor quality or incorrect, → use high-octane gasoline).
	<input type="checkbox"/> brake dragging.
	<input type="checkbox"/> clutch slipping.
	<input type="checkbox"/> engine overheating.
	<input type="checkbox"/> engine oil level too high.
	<input type="checkbox"/> engine oil viscosity too high.
	<input type="checkbox"/> other:

DFI System Troubleshooting Guide

DFI System Troubleshooting Guide

NOTE

- *This is not an exhaustive list, giving every possible cause for each problem listed. It is meant simply as a rough guide to assist the troubleshooting for some of the more common difficulties.*
- *The ECU may be involved in the DFI electrical and ignition system troubles. If these parts and circuits checked out good, be sure to check the ECU for ground and power supply. If the ground and power supply are checked good, replace the ECU.*

Engine Doesn't Start, Starting Difficulty

Symptoms or possible Causes	Actions (chapter)
Starter motor not rotating:	
Ignition and engine stop switches not ON	Turn both switches ON.
Starter lockout switch or neutral switch trouble	Inspect (see chapter 16).
Starter motor trouble	Inspect (see chapter 16).
Battery voltage low	Inspect and charge (see chapter 16).
Starter relays not contacting or operating	Inspect the starter relay (see chapter 16).
Starter button not contacting	Inspect and replace (see chapter 16).
Starter system wiring open or shorted	Inspect the wiring (see chapter 16).
Ignition switch trouble	Inspect and replace (see chapter 16).
Engine stop switch trouble	Inspect and repair or replace (see chapter 16).
Main 30 A or ignition fuse blown	Inspect and replace (see chapter 16).
Starter motor rotating but engine doesn't turn over:	
Starter clutch trouble	Inspect (see chapter 9).
Starter idle gear trouble	Inspect (see chapter 9).
Engine won't turn over:	
Valve seizure	Inspect and replace (see chapter 5).
Cylinder, piston seizure	Inspect and replace (see chapter 5).
Camshaft seizure	Inspect and replace (see chapter 5).
Connecting rod small end seizure	Inspect and replace (see chapter 9).
Connecting rod big end seizure	Inspect and replace (see chapter 9).
Crankshaft seizure	Inspect and replace (see chapter 9).
Transmission gear or bearing seizure	Inspect and replace (see chapter 9).
Balancer bearing seizure	Inspect and replace (see chapter 9).
No fuel flow:	
No or little fuel in tank	Supply fuel (see Owner's Manual).
Fuel pump not rotating	Inspect (see chapter 3).
Fuel injector trouble	Inspect and replace (see chapter 3).
Fuel tank air vent obstructed	Inspect and repair (see chapter 3).
Fuel filter or pump screen clogged	Inspect and replace fuel pump (see chapter 3).
Fuel pressure regulator clogged	Inspect and replace fuel pump (see chapter 3).
Fuel line clogged	Inspect and repair (see chapter 3).
Engine flooded:	
Spark plug dirty, broken or gap maladjusted	Clean spark plugs and adjust plug gap (see chapter 2).

3-50 FUEL SYSTEM (DFI)

DFI System Troubleshooting Guide

Symptoms or possible Causes	Actions (chapter)
Starting technique faulty	When flooded, don't crank engine with throttle fully opened.
No spark or spark weak:	
Ignition and engine stop switches not ON	Turn both switches ON.
Clutch lever not pulled in and gear not in neutral whether sidestand up or not	Pull the lever in and shift the gear in neutral.
Though clutch lever pulled in, sidestand up and gear not in neutral	Sidestand down and clutch lever pulled in whether gear in neutral or not
Vehicle-down sensor coming off	Reinstall (see chapter 3).
Vehicle-down sensor trouble	Inspect (see chapter 3).
ECU ground or power supply trouble	Inspect (see chapter 3).
Battery voltage low	Inspect and charge (see chapter 16).
Spark plug dirty, broken or gap maladjusted	Clean spark plug and adjust plug gap (see chapter 2).
Spark plug cap trouble	Inspect stick coil (see chapter 16).
Spark plug cap shorted or not in good contact	Reinstall or inspect stick coil (see chapter 16).
Spark plug incorrect	Replace it with the correct plug (see chapter 16).
IC igniter in ECU trouble	Inspect (see chapter 16).
Neutral, starter lockout or sidestand switch trouble	Inspect each switch (see chapter 16).
Crankshaft sensor trouble	Inspect (see chapter 16).
Stick coil trouble	Inspect (see chapter 16).
Ignition switch shorted	Inspect and replace (see chapter 16).
Engine stop switch shorted	Inspect and repair or replace (see chapter 16).
Starter system wiring shorted or open	Inspect and repair or replace (see chapter 16).
Main 30 A or ignition fuse blown	Inspect and replace (see chapter 16).
Fuel/air mixture incorrect:	
Air cleaner clogged, poorly sealed or missing	Clean or reinstall (see chapter 3).
Leak from oil filler cap, crankcase breather hose or air cleaner drain hose	Inspect and repair or replace (see chapter 3).
Water or foreign matter in fuel	Change fuel. Inspect and clean fuel system (see chapter 3).
Fuel pressure regulator trouble	Inspect fuel pressure and replace fuel pump (see chapter 3).
Main throttle sensor trouble	Inspect (see chapter 3).
Fuel pressure may be low	Inspect (see chapter 3).
Fuel pump trouble	Inspect (see chapter 3).
Fuel injector trouble	Inspect (see chapter 3).
Inlet air pressure sensor trouble	Inspect (see chapter 3).
Atmospheric pressure sensor trouble	Inspect (see chapter 3).
Inlet air temperature sensor trouble	Inspect (see chapter 3).
Water temperature sensor trouble	Inspect (see chapter 3).
Crankshaft sensor trouble	Inspect (see chapter 3).
Compression low:	
Spark plug loose	Reinstall (see chapter 16).
Cylinder head not sufficiently tightened down	Tighten (see chapter 5).

DFI System Troubleshooting Guide

Symptoms or possible Causes	Actions (chapter)
Cylinder, piston worn	Inspect and replace (see chapter 5).
Piston ring bad (worn, weak, broken or sticking)	Inspect and replace (see chapter 5).
Piston ring/groove clearance excessive	Inspect and replace (see chapter 5).
Cylinder head gasket damaged	Replace (see chapter 5).
Cylinder head warped	Inspect and replace (see chapter 5).
No valve clearance	Adjust (see chapter 2).
Valve guide worn	Inspect and replace (see chapter 5).
Valve spring broken or weak	Inspect and replace (see chapter 5).
Valve not seating properly (valve bent, worn or carbon accumulating on seating surface)	Inspect and repair or replace (see chapter 5).

Poor Running at Low Speed

Symptoms or Possible Causes	Actions (chapter)
Spark weak:	
Battery voltage low	Inspect and charge (see chapter 16).
Spark plug dirty, broken or gap maladjusted	Clean spark plugs and adjust plug gap (see chapter 2).
Spark plug cap trouble	Inspect the stick coil (see chapter 16).
Spark plug cap shorted or not in good contact	Reinstall or inspect stick coil (see chapter 16).
Spark plug incorrect	Replace it with the correct plug (see chapter 16).
IC igniter in ECU trouble	Inspect (see chapter 16).
Crankshaft sensor trouble	Inspect (see chapter 16).
Stick coil trouble	Inspect (see chapter 16).
Fuel/air mixture incorrect:	
Little fuel in tank	Supply fuel (see Owner's Manual).
Air cleaner clogged, poorly sealed, or missing	Clean element or inspect sealing (see chapter 3).
Air cleaner duct loose	Reinstall (see chapter 3).
Air cleaner O-ring damaged	Replace (see chapter 3).
Fuel tank air vent obstructed	Inspect and repair (see chapter 3).
Throttle body assy loose	Reinstall (see chapter 3).
Throttle body assy O-ring damage	Replace (see chapter 3).
Choke lever pulled	Push it (see chapter 3).
Fuel filter or pump screen clogged	Inspect and replace fuel pump (see chapter 3).
Fuel pressure regulator clogged	Inspect fuel pressure and replace fuel pump (see chapter 3).
Fuel line clogged	Inspect and repair (see chapter 3).
Inlet air pressure sensor trouble	Inspect (see chapter 3).
Inlet air temperature sensor trouble	Inspect (see chapter 3).
Thermostat trouble	Inspect and replace (see chapter 4).
Unstable (rough) idling:	
Fuel injector trouble	Inspect (see chapter 3).
Main throttle sensor trouble	Inspect (see chapter 3).
Crankshaft sensor trouble	Inspect (see chapter 3).
Throttle valves not synchronizing	Inspect (see chapter 2).

3-52 FUEL SYSTEM (DFI)

DFI System Troubleshooting Guide

Symptoms or Possible Causes	Actions (chapter)
Inlet air temperature sensor trouble	Inspect (see chapter 3).
Water temperature sensor trouble	Inspect (see chapter 3).
Atmospheric pressure sensor trouble	Inspect (see chapter 3).
Fuel pressure too low or too high	Inspect (see chapter 3).
Battery voltage low	Inspect and charge (see chapter 16).
Incorrect idle speed:	
Water temperature sensor trouble	Inspect (see chapter 3).
Main throttle sensor trouble	Inspect (see chapter 3).
Engine stalls easily:	
Fuel pump trouble	Inspect (see chapter 3).
Fuel injector trouble	Inspect (see chapter 3).
Main throttle sensor trouble	Inspect (see chapter 3).
Camshaft position sensor trouble	Inspect (see chapter 3).
Fuel pressure too low or too high	Inspect (see chapter 3).
Inlet air pressure sensor trouble	Inspect (see chapter 3).
Water temperature sensor trouble	Inspect (see chapter 3).
Inlet air temperature sensor trouble	Inspect (see chapter 3).
Fuel line clogged	Inspect and repair (see chapter 3).
Fuel pressure too low or too high	Inspect (see chapter 3).
Fuel pressure regulator trouble	Inspect fuel pressure and replace fuel pump (see chapter 3).
Crankshaft sensor trouble	Inspect (see chapter 16).
Stick coil trouble	Inspect (see chapter 16).
Compression low:	
Spark plug loose	Reinstall (see chapter 16).
Cylinder head not sufficiently tightened down	Tighten (see chapter 5).
No valve clearance	Adjust (see chapter 2).
Cylinder, piston worn	Inspect and replace (see chapter 5).
Piston ring bad (worn, weak, broken or sticking)	Inspect and replace (see chapter 5).
Piston ring/groove clearance excessive	Inspect and replace (see chapter 5).
Cylinder head gasket damaged	Replace (see chapter 5).
Cylinder head warped	Inspect and replace (see chapter 5).
Valve guide worn or stem seal damaged	Inspect and replace (see chapter 5).
Valve spring broken or weak	Inspect and replace (see chapter 5).
Valve not seating properly (valve bent, worn or carbon accumulating on seating surface)	Inspect and repair or replace (see chapter 5).
Camshaft cam worn	Inspect and replace (see chapter 5).
Hesitation:	
Too low fuel pressure	Inspect (see chapter 3).
Clogged fuel line	Inspect and repair (see chapter 3).
Cracked or obstructed inlet air pressure sensor hose	Inspect and repair or replace (see chapter 3).
Fuel pump trouble	Inspect (see chapter 3).
Fuel injector trouble	Inspect (see chapter 3).
Inlet air temperature sensor trouble	Inspect (see chapter 3).

DFI System Troubleshooting Guide

Symptoms or Possible Causes	Actions (chapter)
Main throttle sensor trouble	Inspect (see chapter 3).
Subthrottle sensor trouble	Inspect (see chapter 3).
Subthrottle valve actuator trouble	Inspect (see chapter 3).
Water temperature sensor trouble	Inspect (see chapter 3).
Atmospheric pressure sensor trouble	Inspect (see chapter 3).
Inlet air pressure sensor trouble	Inspect (see chapter 3).
Loose injector connectors	Remedy (see chapter 3).
Crankshaft sensor trouble	Inspect and repair or replace (see chapter 16).
Stick coil trouble	Inspect and repair or replace (see chapter 16).
Loose terminal of battery (-) lead or engine ground lead	Inspect and repair (see chapter 16).
Delay of ignition timing	Inspect crankshaft sensor and IC igniter in ECU (see chapter 16).
Poor acceleration:	
Choke lever pulled	Push it (see chapter 3).
Too low fuel pressure	Inspect (see chapter 3).
Water or foreign matter in fuel	Change fuel. Inspect and clean fuel system (see chapter 3).
Clogged fuel filter or pump screen	Inspect and replace fuel pump (see chapter 3).
Fuel pump trouble	Inspect (see chapter 3).
Fuel injector trouble	Inspect (see chapter 3).
Inlet air temperature sensor trouble	Inspect (see chapter 3).
Water temperature sensor trouble	Inspect (see chapter 3).
Atmospheric pressure sensor trouble	Inspect (see chapter 3).
Subthrottle sensor trouble	Inspect (see chapter 3).
Subthrottle valve actuator trouble	Inspect (see chapter 3).
Stick coil trouble	Inspect and replace (see chapter 16).
Engine oil level to high	Repair (see chapter 7).
Spark plug dirty, broken or gap maladjusted	Clean spark plugs and adjust plug gap (see chapter 2).
Stumble:	
Too low fuel pressure	Inspect (see chapter 3).
Fuel injector trouble	Inspect (see chapter 3).
Main throttle sensor malfunction	Inspect (see chapter 3).
Subthrottle sensor trouble	Inspect (see chapter 3).
Subthrottle valve actuator trouble	Inspect (see chapter 3).
Water temperature sensor trouble	Inspect (see chapter 3).
Inlet air pressure sensor trouble	Inspect (see chapter 3).
Surge:	
Unstable fuel pressure	Fuel pressure regulator trouble (Inspect and replace fuel pump) or kinked fuel line (Inspect and repair fuel line) (see chapter 3).
Fuel injector trouble	Inspect (see chapter 3).
Water temperature sensor trouble	Inspect (see chapter 3).
Backfiring when deceleration:	

3-54 FUEL SYSTEM (DFI)

DFI System Troubleshooting Guide

Symptoms or Possible Causes	Actions (chapter)
Spark plug dirty, broken or gap maladjusted	Clean spark plugs and adjust plug gap (see chapter 2).
Too low fuel pressure	Inspect (see chapter 3).
Fuel pump trouble	Inspect (see chapter 3).
Main throttle sensor trouble	Inspect (see chapter 3).
Inlet air temperature sensor trouble	Inspect (see chapter 3).
Water temperature sensor trouble	Inspect (see chapter 3).
Atmospheric pressure sensor trouble	Inspect (see chapter 3).
Inlet air pressure sensor trouble	Inspect (see chapter 3).
Vacuum switch valve broken	Inspect and replace (see chapter 5).
Air suction valve trouble	Inspect and replace (see chapter 5).
After fire:	
Crankshaft sensor trouble	Inspect (see chapter 16).
Spark plug burned or gap maladjusted	Adjust plug gap or replace plug (see chapter 2).
Inlet air temperature sensor trouble	Inspect (see chapter 3).
Water temperature sensor trouble	Inspect (see chapter 3).
Atmospheric pressure sensor trouble	Inspect (see chapter 3).
Inlet air pressure sensor trouble	Inspect (see chapter 3).
Fuel injector trouble	Inspect (see chapter 3).
Run-on (dieseling):	
Ignition switch trouble	Inspect and replace (see chapter 16).
Engine stop switch trouble	Inspect and repair or replace (see chapter 16).
Fuel injector trouble	Inspect (see chapter 3).
Loose terminal of battery (-) lead or ECU ground lead	Inspect and repair (see chapter 16).
Carbon accumulating on valve seating surface	Repair (see chapter 5).
Engine overheating	(see Overheating of Troubleshooting Guide, see chapter 17)
Other:	
Engine oil viscosity too high	Change (see chapter 2).
Drive train trouble	Inspect drive chain (see chapter 2) and sprocket (see chapter 11).
Brake dragging	Inspect caliper fluid seal damage or clogging of master cylinder relief and supply ports (see chapter 12).
Clutch slipping	Inspect friction plates for wear (see chapter 6).
Engine overheating	(see Overheating of Troubleshooting Guide, see chapter 17)
Vacuum switch valve trouble	Inspect and replace (see chapter 5).
Air suction valve trouble	Inspect and replace (see chapter 5).
Intermittent any DFI fault and its recovery	Check that DFI connectors are clean and tight, and examine wires for signs of burning or fraying (see chapter 3).

DFI System Troubleshooting Guide

Poor Running or No Power at High Speed

Symptoms or Possible Causes	Actions (chapter)
Firing incorrect:	
Spark plug dirty, broken or maladjusted	Clean spark plug and adjust plug gap (see chapter 2).
Spark plug cap trouble	Inspect stick coil (see chapter 16).
Spark plug cap shorted or not in good contact	Reinstall or inspect stick coil (see chapter 16).
Spark plug incorrect	Replace it with the correct plug (see chapter 16).
IC igniter in ECU trouble	Inspect (see chapter 16).
Crankshaft sensor trouble	Inspect (see chapter 16).
Stick coil trouble	Inspect (see chapter 16).
Fuel/air mixture incorrect:	
Choke lever pulled	Push it (see chapter 3).
Air cleaner clogged, poorly sealed or missing	Clean element or inspect sealing (see chapter 3).
Air cleaner duct loose	Reinstall (see chapter 3).
Air cleaner O-ring damaged	Replace (see chapter 3).
Water or foreign matter in fuel	Change fuel. Inspect and clean fuel system (see chapter 3).
Throttle body assy loose	Reinstall (see chapter 3).
Throttle body assy O-ring damaged	Replace (see chapter 3).
Fuel tank air vent obstructed	Inspect and repair (see chapter 3).
Fuel line clogged	Inspect and repair (see chapter 3).
Fuel pump operates intermittently and often ECU fuse blows.	Pump bearings may wear. Replace the pump (see chapter 3).
Fuel pump trouble	Inspect (see chapter 3).
Inlet air temperature sensor trouble	Inspect (see chapter 3).
Main throttle sensor trouble	Inspect (see chapter 3).
Atmospheric pressure sensor trouble	Inspect (see chapter 3).
Inlet air pressure sensor trouble	Inspect (see chapter 3).
Cracked or obstructed inlet air pressure sensor hose	Inspect and repair or replace (see chapter 3).
Injector clogged	Visually inspect and replace (see chapter 3).
Compression low:	
Spark plug loose	Reinstall (see chapter 16).
Cylinder head not sufficiently tightened down	Tighten (see chapter 5).
No valve clearance	Adjust (see chapter 2).
Cylinder, piston worn	Inspect and replace (see chapter 5).
Piston ring bad (worn, weak, broken or sticking)	Inspect and replace (see chapter 5).
Piston ring/groove clearance excessive	Inspect and replace (see chapter 5).
Cylinder head gasket damaged	Replace (see chapter 5).
Cylinder head warped	Inspect and replace (see chapter 5).
Valve spring broken or weak	Inspect and replace (see chapter 5).
Valve not seating properly (valve bent , worn or carbon accumulating on the seating surface)	Inspect and repair or replace (see chapter 5).
Knocking:	
Carbon built up in combustion chamber	Repair (see chapter 5).

3-56 FUEL SYSTEM (DFI)

DFI System Troubleshooting Guide

Symptoms or Possible Causes	Actions (chapter)
Fuel poor quality or incorrect (Use the gasoline recommended in the Owner's Manual)	Change fuel (see chapter 3).
Spark plug incorrect	Replace it with the correct plug (see chapter 16).
Stick coil trouble	Inspect (see chapter 16).
IC igniter in ECU trouble	Inspect (see chapter 16).
Inlet air temperature sensor trouble	Inspect (see chapter 3).
Atmospheric pressure sensor trouble	Inspect (see chapter 3).
Miscellaneous:	
Subthrottle sensor trouble	Inspect (see chapter 3).
Subthrottle valve actuator trouble	Inspect (see chapter 3).
Speed sensor trouble	Inspect (see chapter 3).
Throttle valves won't fully open	Inspect throttle cable and lever linkage (see chapter 3).
Brake dragging	Inspect caliper fluid seal damage or clogging of master cylinder relief and supply ports (see chapter 12).
Clutch slipping	Inspect friction plates for wear (see chapter 6).
Engine overheating - water temperature sensor, crankshaft sensor or speed sensor trouble	(see Overheating of Troubleshooting Guide in chapter 17)
Engine oil level too high	Repair (see chapter 7).
Engine oil viscosity too high	Change (see chapter 3).
Drive train trouble	Inspect drive chain (see chapter 2) and sprockets (see chapter 11).
Camshaft cam worn	Inspect and replace (see chapter 5).
Vacuum switch valve trouble	Inspect and replace (see chapter 5).
Air suction valve trouble	Inspect and replace (see chapter 5).
Catalytic converters melt down due to muffler overheating (KLEEN)	Replace muffler (see chapter 5).
Exhaust Smokes Excessively:	
(White smokes)	
Piston oil ring worn	Inspect and replace (see chapter 5).
Cylinder worn	Inspect and replace (see chapter 5).
Valve oil seal damaged	Replace (see chapter 5).
Valve guide worn	Replace the guide (see chapter 5).
Engine oil level too high	Repair (see chapter 7).
(Black smoke)	
Air cleaner clogged	Clean (see chapter 3).
Choke lever pulled	Push it (see chapter 3).
Too high fuel pressure	Inspect (see chapter 3).
Injector stuck open	Inspect (see chapter 3).
Water temperature sensor trouble	Inspect and replace (see chapter 3).
Inlet air temperature sensor trouble	Inspect and replace (see chapter 3).
(Brown smoke)	
Air cleaner duct loose	Reinstall (see chapter 3).
Air cleaner O-ring damaged	Replace (see chapter 3).

DFI System Troubleshooting Guide

Symptoms or Possible Causes	Actions (chapter)
Too low fuel pressure	Inspect fuel line and fuel pump (see chapter 3).
Water temperature sensor trouble	Inspect and replace (see chapter 3).
Inlet air temperature sensor trouble	Inspect and replace (see chapter 3).

3-58 FUEL SYSTEM (DFI)

Self-Diagnosis

Self-diagnosis Outline

The self-diagnosis system has three modes and can be switched to another mode by grounding the self-diagnosis indicate terminal [A].



User Mode

The ECU notifies the rider of troubles in DFI system and ignition system by lighting the FI indicator when DFI system and ignition system parts a faulty, and initiates fail-safe function. In case of serious troubles ECU stops the injection/ignition/starter motor operation to prevent battery discharge, and notifies the rider that the engine will no start.

Dealer Mode 1

The FI indicator LED light emits service code(s) to show the problem(s) which the DFI system and ignition system has at the moment of diagnosis.

Dealer Mode 2

The FI indicator light LED emits service code(s) to show the problem(s) which the DFI system and ignition system had in the past.

Self-diagnosis Function

The self-diagnosis indicates problems with the parts, wiring, and ECU in the DFI system and ignition system.

The ECU [C] always monitors each DFI circuit [A] for problems by measuring the voltage [B]. This circuit includes parts [D], and wiring [E].

When the circuit is open (problem), the following are possible problems.

- Disconnection [F] in the Parts
- Disconnection [G] in the Wiring
- Disconnection [H] in the ECU

When the FI indicator indicates a problem, the ECU has the possibility of the problem as well as the parts and the wiring outside the the ECU.

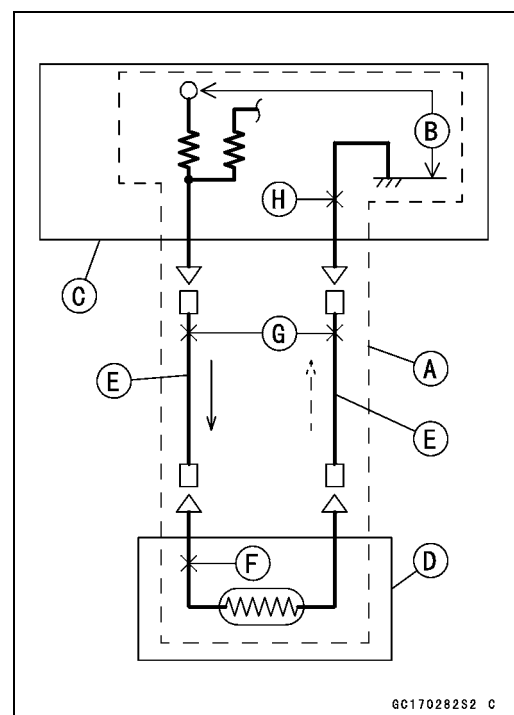

GC170282S2 C

Self-Diagnosis

Self-diagnosis Procedures

○When a problem occurs with the DFI system and ignition system, the DFI indicator LED light [A] goes on.

NOTE

- Use a fully charged battery when conducting self-diagnosis. Otherwise, the LED light blinks very slowly or doesn't blink.
- Keep the display switch grounded during self-diagnosis, with a auxiliary lead.



- Remove the strage box (see Frame chapter) and pull the self-diagnosis indicator terminal [G].
- Turn on the ignition switch.
- Connect an auxiliary a lead [E] for grounding to the self-diagnosis indicator terminals.
- Enter the self-diagnosis dealer mode 1 by grounding [A] the self-diagnosis indicator terminal to the ground for more than 2 seconds [C], and then keep it grounded continuously [D].
- Count the blinks of the LED light to read the service code.

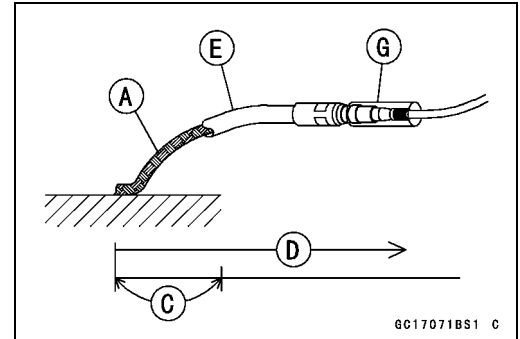

- Enter the self-diagnosis dealer mode 2 by repeat opening [B] and grounding [A] the lead more than five times [F] within 2 seconds [C] after the lead is first grounded, and then keep it grounded continuously [D] for more than 2 seconds.
- Count the blinks of the LED light to read the service code.

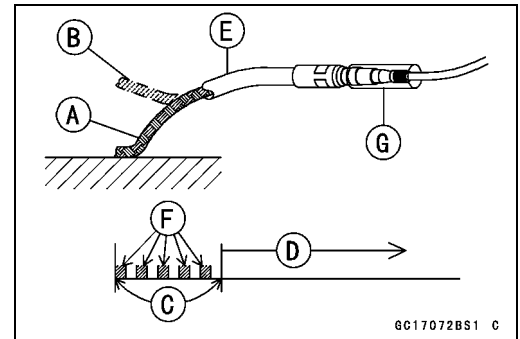

NOTE

- If the self-diagnosis mode is in user mode or dealer mode 1 then you need to enter the dealer mode 2, turn off the ignition switch once.

3-60 FUEL SYSTEM (DFI)

Self-Diagnosis

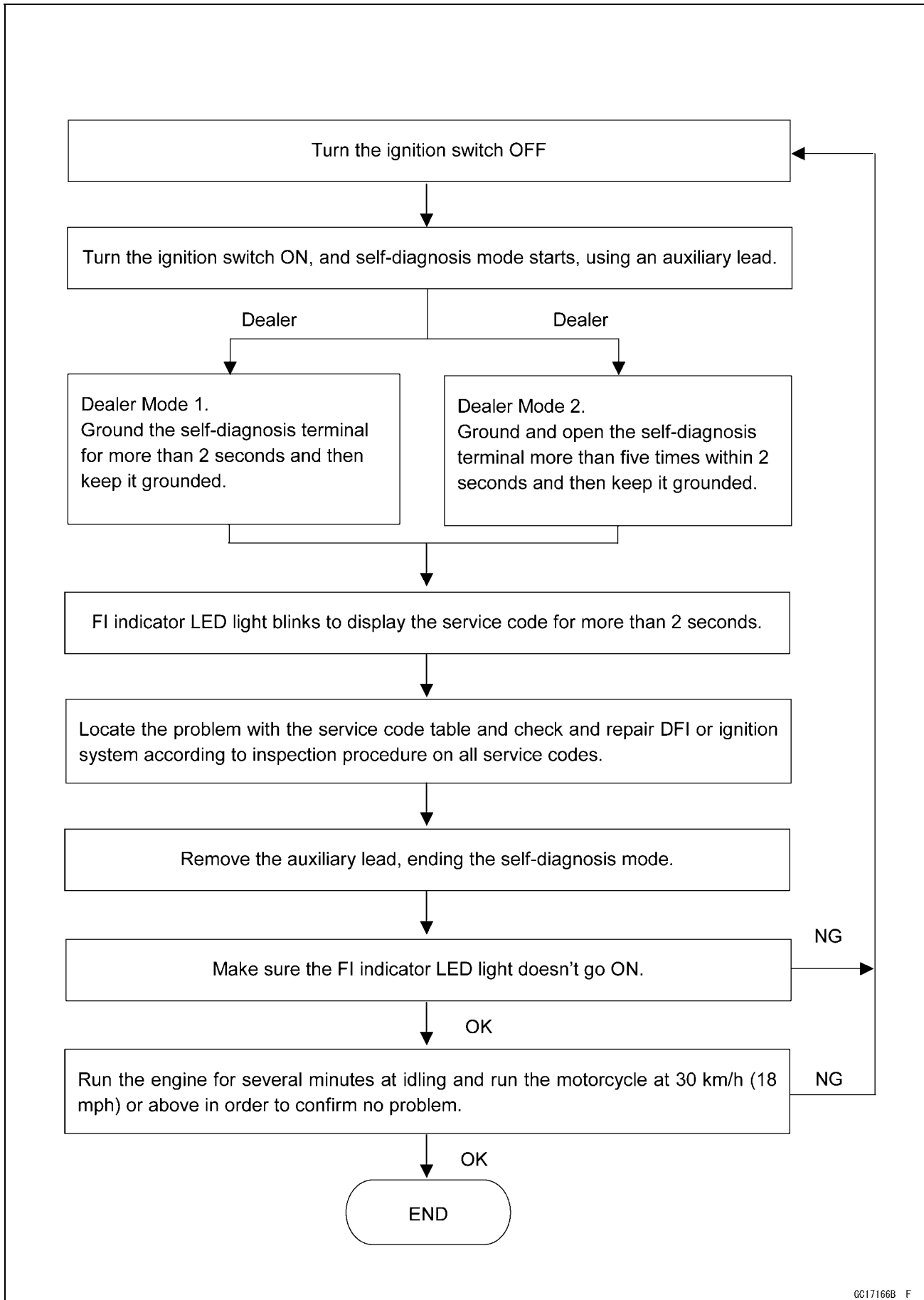

Self-Diagnosis

How to Read Service Codes

- Service codes are shown by a series of long or short blinks of the FI indicator LED light as shown below.
- Read 10th digit and unit digit as the FI indicator LED light blinks.
- When there are a number of problems, all the service codes can be stored and the display will begin starting from the lowest number service code in the numerical order. Then after completing all codes, the display is repeated until the self-diagnosis indicator terminal is open.
- If there is no problem, no code is shown.
- Repeat blinks [C] or light [B], unlight [A].

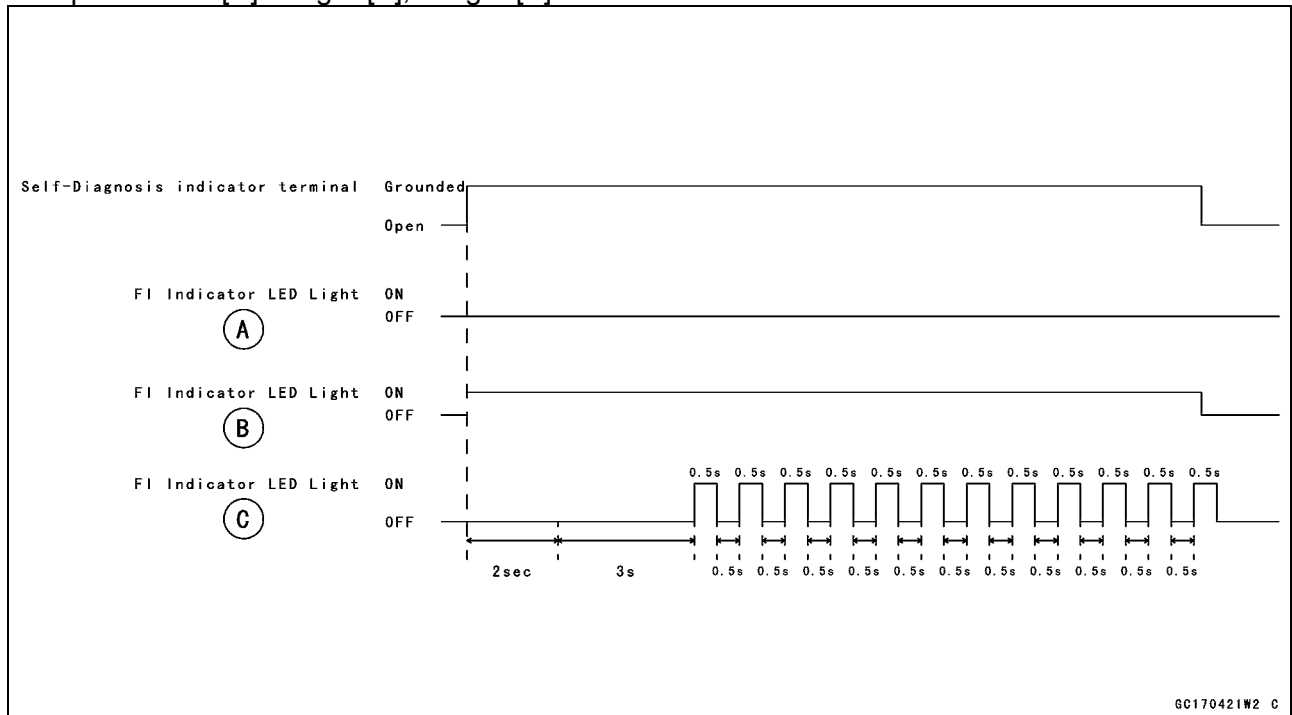

○For example, if four problems occurred in the order of 12, 21, the service codes are displayed from the lowest number in the order listed.

(12 → 21) → (12 → 21) → ... (repeated)

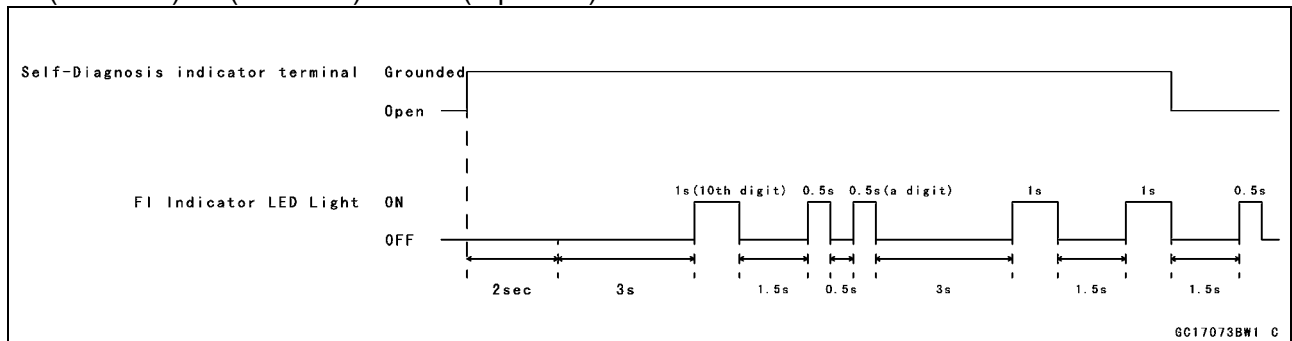

○If the problem is with the following parts, the ECU cannot memorize these problems, the FI indicator LED light doesn't go on, and no service codes can be displayed.

- FI Indicator LED Light
- Fuel Pump
- Pressure Regulator (Fuel Pressure, Fuel Flow Rate)
- DFI Main Relay
- Ignition Coil Secondary Wiring (see Electrical System chapter)
- ECU Power Source Wiring and Ground Wiring (see ECU Inspection in this chapter)

3-62 FUEL SYSTEM (DFI)











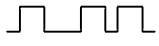

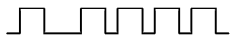

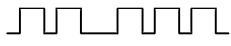
Self-Diagnosis

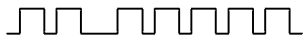
How to Erase Service Codes

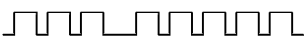



○ Even if the ignition SW is turned OFF, or the problem is solved, all service codes remain in the ECU.

If the battery or the ECU are disconnected, all service codes will disappear in the ECU.

Service Code Table

Service Code	FI Indicator LED Light	Problems (1)
11	 ON OFF	Throttle sensor (ZX1200-B1/B2), main throttle sensor (ZX1200-B3), malfunction, wiring open or short
12		Inlet air pressure sensor malfunction, wiring open or short
13		Inlet air temperature sensor malfunction, wiring open or short
14		Water temperature sensor malfunction, wiring open or short
15		Atmospheric pressure sensor malfunction, wiring open or short
21		Crankshaft sensor malfunction, wiring open or short
23		Camshaft position sensor malfunction, wiring open or short
24		Speed sensor malfunction, wiring open or short
25		Gear position switch malfunction, wiring open or short
31		Vehicle-down sensor, malfunction, wiring open or short
32		Subthrottle sensor malfunction, wiring open or short
35		Immobilizer amplifier malfunction
36		Blank key detection
41		Injector #1 malfunction, wiring open or short
42		Injector #2 malfunction, wiring open or short
43		Injector #3 malfunction, wiring open or short
44		Injector #4 malfunction, wiring open or short

Self-Diagnosis

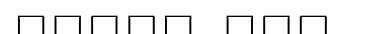
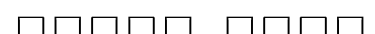
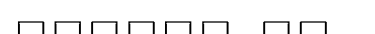
Service Code	FI Indicator LED Light	Problems (1)
45		Fuel pump relay wiring open
46		Fuel pump relay stuck ON
51		Ignition coil #1 malfunction, wiring open or short
52		Ignition coil #2 malfunction, wiring open or short
53		Ignition coil #3 malfunction, wiring open or short
54		Ignition coil #4 malfunction, wiring open or short
62		Subthrottle valve actuator malfunction, wiring open or short

Footnotes

(1) The ECU may be involved in these problems. If all the parts and circuits checked out good, be sure to check the ECU for ground and power supply. If the ground and power supply are checked good, replace the ECU.

3-64 FUEL SYSTEM (DFI)

Self-Diagnosis

Backups

○The ECU takes the following measures to prevent engine damage when the DFI or the ignition system parts have troubles.

Service Codes	Parts	Output Signal Usable Range or Criteria	Backups by ECU
11	Throttle Sensor (ZX1200-B1/B2), Main Throttle Sensor (ZX1200-B3)	ZX1200-B1/B2: Throttle Valve Opening Angle $\theta = 6.5^\circ \sim + 86.5^\circ$ ZX1200-B3: Main Throttle Sensor Output Voltage 0.2 ~ 4.8 V	If the throttle sensor system fails (the signal is out of the usable range, wiring short or open), the ECU locks ignition timing into the ignition timing at closed throttle position and sets the DFI in the D-J method. Also, the throttle sensor system and inlet air pressure fails, the ECU locks ignition timing into the ignition timing at closed throttle position and sets the DFI in the α -N method.
12	Inlet Air Pressure Sensor	Inlet Air Pressure (absolute) $P_v = 100 \text{ mmHg} \sim 900 \text{ mmHg}$	If the inlet air pressure sensor system fails (the signal P_v is out of the usable range, wiring short or open), the ECU sets the DFI in the α - N method (1).
13	Inlet Air Temperature Sensor	Inlet Air Temperature $T_a = - 47^\circ\text{C} \sim + 178^\circ\text{C}$	If the inlet air temperature sensor fails (the signal is out of the usable range, wiring short or open), the ECU sets T_a at 45°C .
14	Water Temperature Sensor	Water Temperature $T_w = - 30^\circ\text{C} \sim + 120^\circ\text{C}$	If the water temperature sensor system fails (the signal is out of the usable range, wiring short or open), the ECU sets T_w at 86°C .
15	Atmospheric Pressure Sensor	Absolute Atmospheric Pressure $P_a = 100 \text{ mmHg} \sim 900 \text{ mmHg}$	If the atmospheric pressure sensor system fails (the signal is out of the usable range, wiring short or open), the ECU sets P_a at 760 mmHg (the standard atmospheric pressure).
21	Crankshaft Sensor	Crankshaft sensor must send signals (output voltage) 8 continuously to the ECU.	If crankshaft sensor generates less than 8 or more signals, the engine stops by itself.
23	Camshaft Position Sensor	Camshaft position sensor must send one signal (output signal) to the ECU at the two cranking	If the camshaft position sensor system fails (the signal is missing, wiring short or open), the ECU continues to ignite cylinders in the same sequence following the last good signal.
24	Speed Sensor	The output voltage of the rectangular wave: Low Level: 1 V to 0 High Level: 4 V to 5 V	If the speed sensor system fails (no conductivity, wiring short or open), revolution limiter begin to start before getting to the specified speed.
25	Gear Position Switch	Gear Position Switch ON = Ground OFF = 5 V or more (neutral), 5 V or less	If the gear position switch system fails (the signal is out of the usable range, wiring short or open), the ECU locks in 6th gear position.
31	Vehicle-down Sensor	Vehicle-down Sensor Output Voltage (signal) $V_d = 0.4 \text{ V} \sim 4.4 \text{ V}$	If the vehicle-down sensor system has failures (the output voltage V_d is out of the usable range, wiring short or open), the ECU shuts off the fuel pump, the fuel injectors and the ignition system.

Self-Diagnosis

Service Codes	Parts	Output Signal Usable Range or Criteria	Backups by ECU
32	Subthrottle Sensor	Subthrottle Sensor Output Voltage 0.15 ~ 4.85 V	If the subthrottle sensor system fails (the signal is out of the usable range, wiring short or open), the actuator locks subthrottle valve at full open position.
35	Immobilizer Amplifier	—	If the immobilizer system fails (no signal, wiring short or open), the vehicle is no start and run.
36	Master or User Key	The user or master key must use register key.	If the blank key or broken key is used, the vehicle is no start and run.
41	Fuel Injector #1*	The injector must send signals (output voltage) continuously to the ECU.	If the injector #1 fails (no signal, wiring short or open), the ECU shuts off the signal to the injector. Fuel is not supplied to the cylinder #1, though the engine keeps running.
42	Fuel Injector #2*	The injector must send signals (output voltage) continuously to the ECU.	If the injector #2 fails (no signal, wiring short or open), the ECU shuts off the signal to the injector. Fuel is not supplied to the cylinder #2, though the engine keeps running.
43	Fuel Injector #3*	The injector must send signals (output voltage) continuously to the ECU.	If the injector #3 fails (no signal, wiring short or open), the ECU shuts off the signal to the injector. Fuel is not supplied to the cylinder #3, though the engine keeps running.
44	Fuel Injector #4*	The injector must send signals (output voltage) continuously to the ECU.	If the injector #4 fails (no signal, wiring short or open), the ECU shuts off the signal to the injector. Fuel is not supplied to the cylinder #4, though the engine keeps running.
51	Stick Coil #1 (Ignition Coil)*	The ignition coil primary winding must send signals (output voltage) continuously to the ECU.	If the ignition primary winding #1 has failures (no signal, wiring short or open), the ECU shuts off the injector #1 to stop fuel to the cylinder #1, though the engine keeps running.
52	Stick Coil #2 (Ignition Coil)*	The ignition coil primary winding must send signals (output voltage) continuously to the ECU.	If the ignition primary winding #2 has failures (no signal, wiring short or open), the ECU shuts off the injector #2 to stop fuel to the cylinder #2, though the engine keeps running.
53	Stick Coil #3 (Ignition Coil)*	The ignition coil primary winding must send signals (output voltage) continuously to the ECU.	If the ignition primary winding #3 has failures (no signal, wiring short or open), the ECU shuts off the injector #3 to stop fuel to the cylinder #3, though the engine keeps running.
54	Stick Coil #4 (Ignition Coil)*	The ignition coil primary winding must send signals (output voltage) continuously to the ECU.	If the ignition primary winding #4 has failures (no signal, wiring short or open), the ECU shuts off the injector #4 to stop fuel to the cylinder #4, though the engine keeps running.
62	Subthrottle Valve Actuator	The actuator operates open and close of the subthrottle valve by the pulse signal from the ECU.	If the sub throttle actuator fails (the signal is out to the usable range, wiring short or open), the ECU stops the current to the actuator.

3-66 FUEL SYSTEM (DFI)

Self-Diagnosis

Note:

(1) α – N Method: the DFI control method from medium to heavy engine load. When the engine load is light like at idling or low speed, the ECU determines the injection quantity by calculating from the throttle vacuum (vacuum sensor output voltage) and engine speed (crankshaft sensor output voltage). This method is called D-J method. As the engine speed increases, and the engine load turns middle to heavy, the ECU determines the injection quantity by calculating from the throttle opening (throttle sensor output voltage) and the engine speed. This method is called α – N method.

* This depends on the number of stopped cylinders.

Throttle Sensor (Service Code 11) (ZX1200-B1/B2)

The throttle sensor is a rotating variable resistor that change output voltage according to throttle operating. The ECU senses this voltage change and determines fuel injection quantity, and ignition timing according to engine rpm, and throttle opening.

- Input Terminal [A]
- Output Terminal [B]
- Ground Terminal [C]
- Front [D]

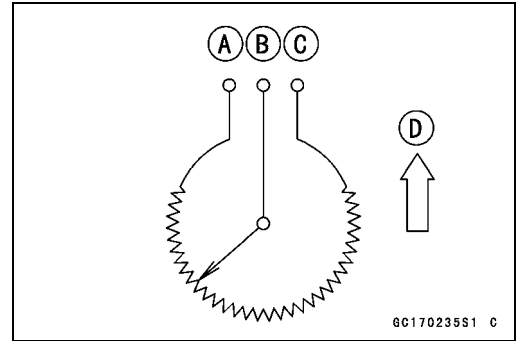

Throttle Sensor Removal/Adjustment

CAUTION
<p>Do not remove or adjust the throttle sensor [A] since it has been adjusted and set with precision at the factory.</p> <p>Never drop the sensor, especially on a hard surface. Such a shock to the sensor can damage it.</p> <p>Do not connect the throttle sensor connector to the inlet air pressure sensor, because the inlet air pressure sensor is broken by opposite electrical connection.</p>

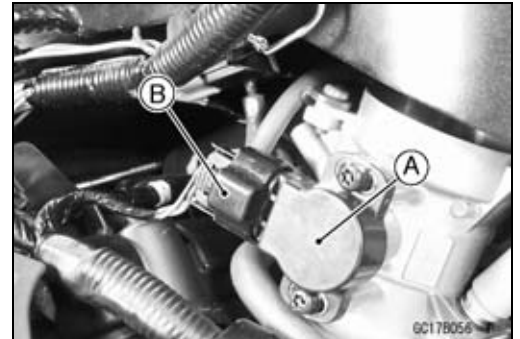

Throttle Sensor Connector [B]

Input Voltage Inspection

NOTE

- Be sure the battery is fully charged.
- The inspection is the same as "Input Voltage Inspection" of the vacuum sensor and the atmospheric pressure sensor.

- Turn the ignition switch OFF.
- Remove the ECU (see this chapter). Do not disconnect the ECU connectors.
- Connect a digital voltmeter [A] to the connector [B], using the needle adapter set.

Special Tool - Needle Adapter Set: 57001-1457

- Measure the input voltage with the engine stopped, and with the connectors joined.
- Turn the ignition switch ON.

Throttle Sensor Input Voltage

Connections to ECU Connector

- Meter (+) → BL/W lead (terminal 41)
- Meter (-) → BR/BK lead (terminal 54)

Input Voltage at ECU Connector

Standard: 4.75 ~ 5.25 V DC

- Turn the ignition switch OFF.
- ★ If the reading of input voltage is less than the standard, check the ECU for its ground, power supply and wiring shorted.
- ★ If the input voltage is within the standard range, check the input voltage at the throttle sensor connector.
- Remove the left lower inner cover (see Frame chapter).

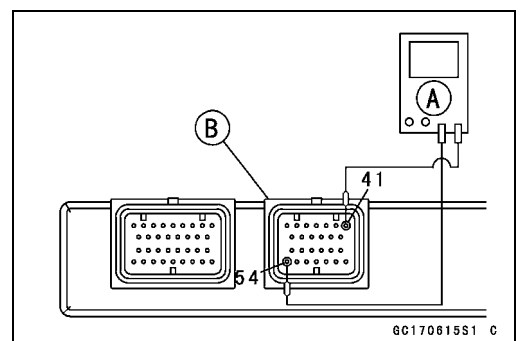

3-68 FUEL SYSTEM (DFI)

Throttle Sensor (Service Code 11) (ZX1200-B1/B2)

- Disconnect the throttle sensor connector and connect the harness adapter between the sub harness connector and throttle sensor connector.
- Connect a digital meter [A] to the harness adapter leads [B].

Special Tool - Throttle Sensor Harness Adapter #2: 57001-1408

- Measure the sensor input voltage with the engine stopped, and with the connector joined.
- Turn the ignition switch ON.

Throttle Sensor Input Voltage Connections to Sensor

Meter (+) → BL/W lead [C]

Meter (-) → BR/BK lead [D]

Input Voltage at Sensor

Standard: 4.75 ~ 5.25 V DC

- Turn the ignition switch OFF.
- ★ If the reading is out of the range, check the wiring (see wiring diagram in this section).
- ★ If the reading is good, check the output voltage of the sensor.

Output Voltage Inspection

- Measure the output voltage at the ECU in the same way as input voltage inspection. Note the following.

Digital Voltmeter [A]

Connector [B]

Special Tool - Needle Adapter Set: 57001-1457

- Start the engine and warm it up thoroughly.
- Check idle speed to ensure throttle opening is correct.

Idle Speed

Standard: 1 000 ±50 r/min (rpm)

- ★ If the idle speed is out of the specified range, adjust the idle speed (see Idle Speed Inspection in the Periodic Maintenance chapter).
- Turn the ignition switch OFF.
- Measure the output voltage with the engine stopped, and with the connector joined.
- Turn the ignition switch ON.
- Measure the output voltage when the throttle is fully opened or completely closed.

Throttle Sensor Output Voltage Connections to ECU

Meter (+) → Y/W lead (terminal 56)

Meter (-) → BR/BK lead (terminal 54)

Output Voltage at ECU

Standard: 1.07 ~ 4.61 V DC (at idle throttle opening to full throttle opening)

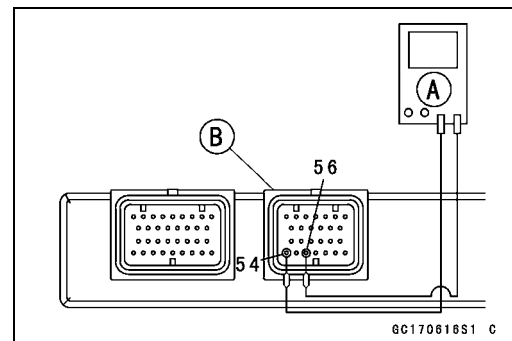
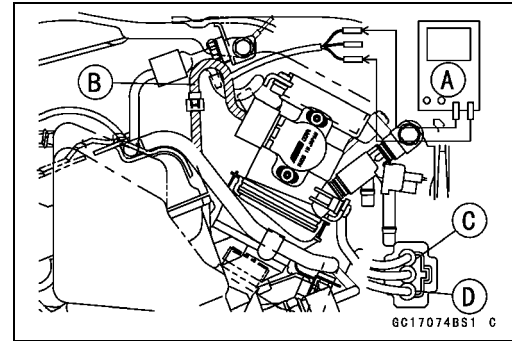

Throttle Sensor (Service Code 11) (ZX1200-B1/B2)

NOTE

- *The throttle sensor is operating correctly if the following voltages are obtained:*
 - *1.07 VDC (or slightly higher) with the throttle at the idle position.*
 - *4.61 VDC (or slightly lower) with the throttle at the fully open position.*

CAUTION

Do not remove or adjust the throttle sensor. It has been adjusted and set with precision at the factory. Never drop the sensor can especially on a hard surface. A shock to the sensor can damage it.

- ★ If the output voltage is within the standard range, check the ECU for a good ground, and power supply (see this chapter). If the ground and power supply are good, replace the ECU.
 - ★ If the output voltage is far out of the standard range (e.g. when the wiring is open, the reading is 0 V), check the output voltage again at the sensor connector.
 - Disconnect the throttle sensor connector and connect the harness adapter between the sub harness connector and throttle sensor connector.
 - Connect a digital meter [A] to the harness adapter leads [B].
- Special Tool - Throttle Sensor Harness Adapter #2: 57001-1408**
- Measure the sensor output voltage with the engine stopped, and with the connector joined.
 - Turn the ignition switch ON.
 - Measure the output voltage when the throttle is fully opened or completely closed.

Throttle Sensor Output Voltage

Connections to Sensor

- Meter (+)** → Y/W lead [C]
- Meter (-)** → BR/BK lead [D]

Output Voltage at Sensor

- Standard:** 1.07 ~ 4.61 V DC (at idle throttle opening to full throttle opening)

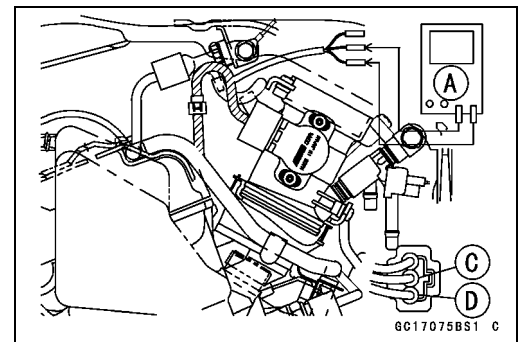

3-70 FUEL SYSTEM (DFI)

Throttle Sensor (Service Code 11) (ZX1200-B1/B2)

NOTE

- The throttle sensor is operating correctly if the following voltages are obtained:
 - 1.07 VDC (or slightly higher) with the throttle at the idle position.
 - 4.61 VDC (or slightly lower) with the throttle at the fully open position.

CAUTION

Do not remove or adjust the throttle sensor. It has been adjusted and set with precision at the factory. Never drop the sensor, especially on a hard surface. A shock to the sensor can damage it.

NOTE

- The standard voltage marked with an asterisk refers to the value when the voltage reading at the Input Voltage Inspection shows 5V exactly.
- When the input voltage reading shows other than 5V, derive a voltage range as follows.
Example:
In the case of a input voltage of 4.75 V.
 $1.07 \times 4.75 \div 5.00 = 1.02 \text{ V}$
 $4.61 \times 4.75 \div 5.00 = 4.38 \text{ V}$
Thus, the valid range is 1.02 ~ 4.38 V

- After throttle sensor voltage inspection, remove the harness adapter.
- ★ If the reading is out of the standard range, inspect the throttle sensor resistance.
- ★ If the output voltage is normal, check the wiring for continuity (see next diagram).

Resistance Inspection

- Turn the ignition switch OFF.
- Disconnect the throttle sensor connector.
- Connect a digital meter [A] to the throttle sensor connector [B].
- Measure the throttle sensor resistance.

Throttle Sensor Resistance

Connections: BL/W lead [C] ↔ BR/BK lead [D]

Standard: 4 ~ 6 kΩ

- ★ If the reading is out of the range, replace the throttle body assy.
- ★ If the reading is within the range, but the problem still exists, replace the ECU (see this chapter).

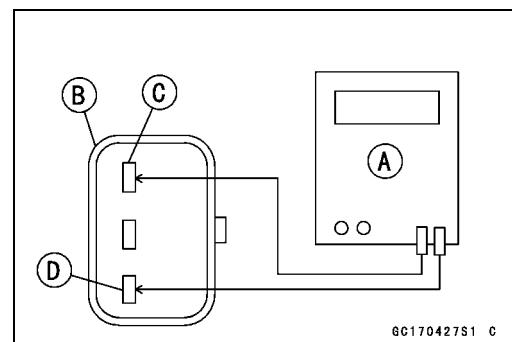

Throttle Sensor (Service Code 11) (ZX1200-B1/B2)

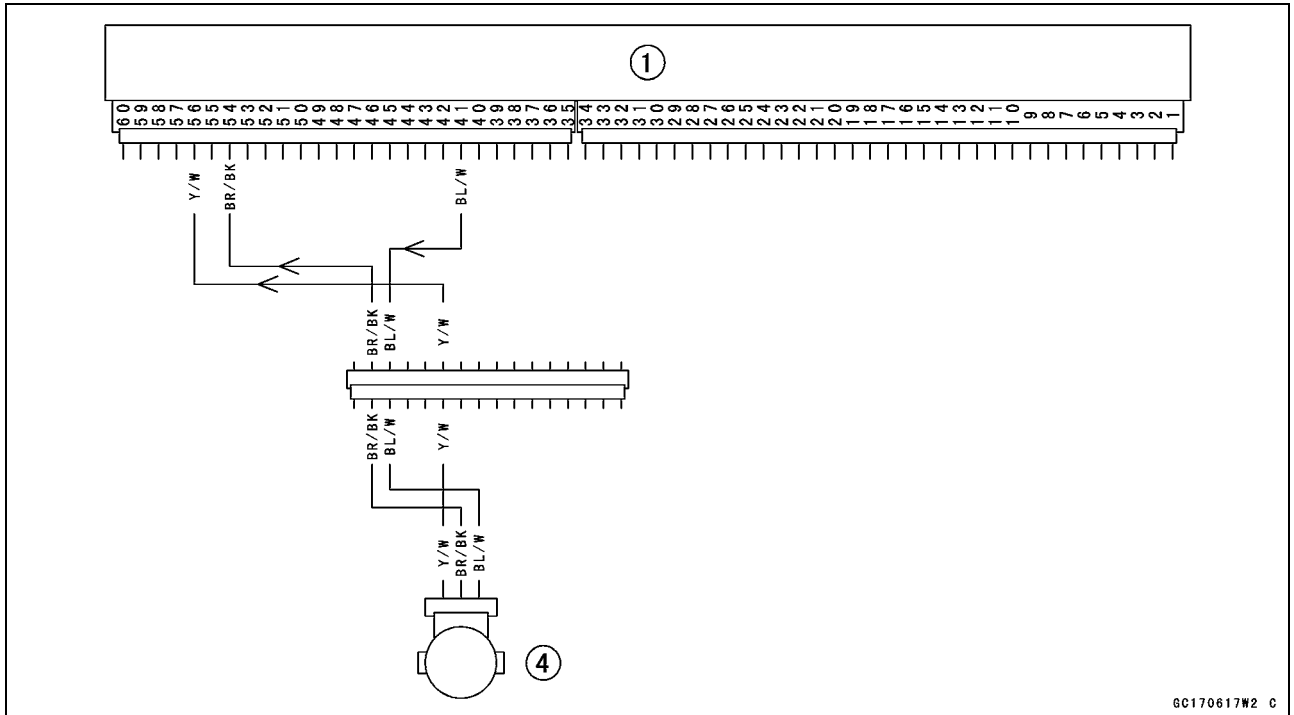

→: Signal

ECU [1]

Throttle Sensor [4]

3-72 FUEL SYSTEM (DFI)

Main Throttle Sensor (Service Code 11) (ZX1200-B3)

Main Throttle Sensor Removal/Adjustment

CAUTION

Do not remove or adjust the main throttle sensor [A] since it has been adjusted and set with precision at the factory.

Never drop the sensor, especially on a hard surface. Such a shock to the sensor can damage it.

Main Throttle Sensor Connector (gray) [B]

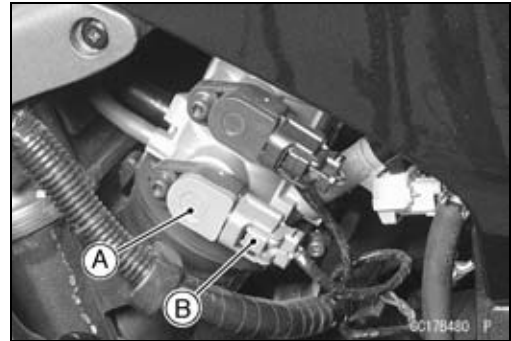

Input Voltage Inspection

NOTE

○Be sure the battery is fully charged.

- Turn the ignition switch OFF.
- Disconnect the main throttle sensor connector (gray) [A] and connect the harness adapter [B] between these connectors.
- Connect a digital meter to the harness adapter lead.

Special Tool - Throttle Sensor Harness Adapter: 57001-1538

- Measure the sensor input voltage with the engine stopped and with the connector joined.
- Turn the ignition switch ON.

Main Throttle Sensor Input Voltage Connections to Adapter

Meter (+) → BK (sensor BL/W) lead

Meter (-) → W (sensor BR/BK) lead

Standard: 4.75 ~ 5.25 V DC

- Turn the ignition switch OFF.
- ★ If the input voltage is normal, check the sensor output voltage.
- ★ If the input voltage is less than the standard, remove the ECU and check the wiring between these connectors.
- Disconnect the ECU and sensor connectors.

Wiring Connection

ECU Connector [A] ↔ Throttle Sensor Connector [B]

BL/W lead (ECU terminal 10)

BR/BK lead (ECU terminal 28)

- ★ If the wiring is good, check the ECU for its ground and power supply (see ECU section).

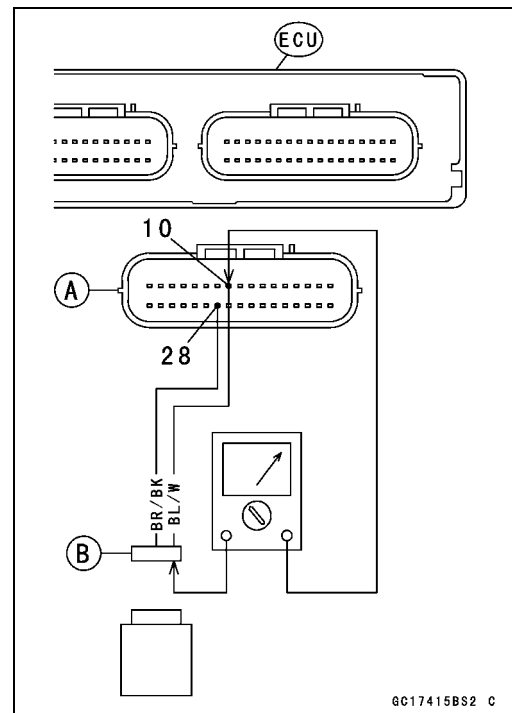
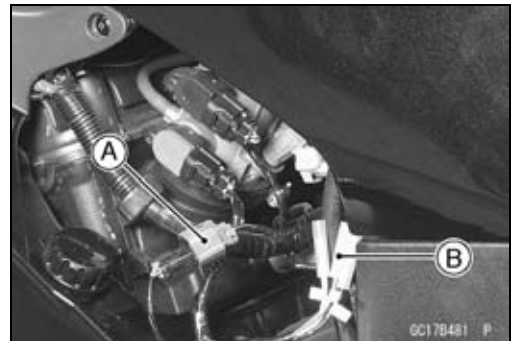

Main Throttle Sensor (Service Code 11) (ZX1200-B3)

Output Voltage Inspection

- Measure the output voltage at the main throttle sensor in the same way as input voltage inspection, Note the following.
- Disconnect the main throttle sensor connector (gray) [A] and connect the harness adapter [B] between these connectors.

Special Tool - Throttle Sensor Harness Adapter: 57001-1538

- Start the engine and warm it up thoroughly.
- Check idle speed to ensure the throttle opening is correct.

Idle Speed

Standard: 1 000 ±50 r/min (rpm)

- ★ If the idle speed is out of the specified range, adjust it (see Idle Speed Inspection in the Periodic Maintenance chapter).
- Turn off the ignition switch.
- Measure the output voltage of the sensor with the engine stopped, and with the connector joined.
- Turn the ignition switch ON.

Main Throttle Sensor Output Voltage Connections to Adapter

Meter (+) → R (sensor Y/W) lead

Meter (-) → W (sensor BR/BK) lead

Standard:

1.06 ~ 1.10 V DC (at idle throttle opening)

4.26 ~ 4.86 V DC (at full throttle opening)

- ★ If the output voltage is out of the standard, inspect the main throttle sensor resistance.
- ★ If the output voltage is normal, check the wiring for continuity.

Wiring Connection

ECU Connector [A] ↔ Throttle Sensor Connector [B]

Y/W lead (ECU terminal 7)

BR/BK lead (ECU terminal 28)

- ★ If the wiring is good, check the ECU for its ground and power supply (see ECU section).

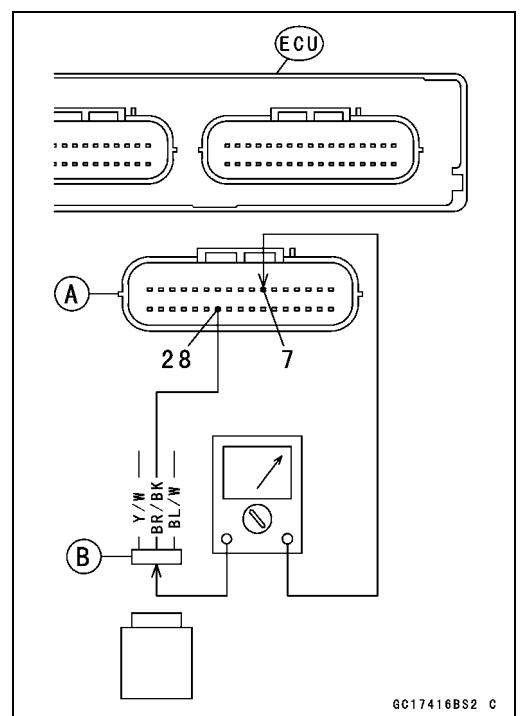
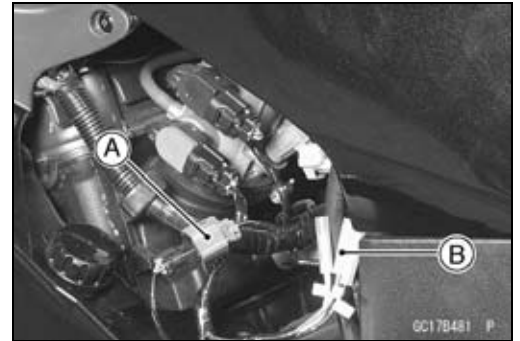

3-74 FUEL SYSTEM (DFI)

Main Throttle Sensor (Service Code 11) (ZX1200-B3)

Resistance Inspection

- Turn the ignition switch OFF.
- Disconnect the main throttle sensor connector.
- Connect a digital meter [A] to the main throttle sensor connector [B].
- Measure the main throttle sensor resistance.

Main Throttle Sensor Resistance

Connections: BL/W lead [C] ↔ BR/BK lead [D]

Standard: 4 ~ 6 kΩ

- ★ If the reading is out of the range, replace the throttle body assy.
- ★ If the reading is within the range, but the problem still exists, replace the ECU (see this chapter).

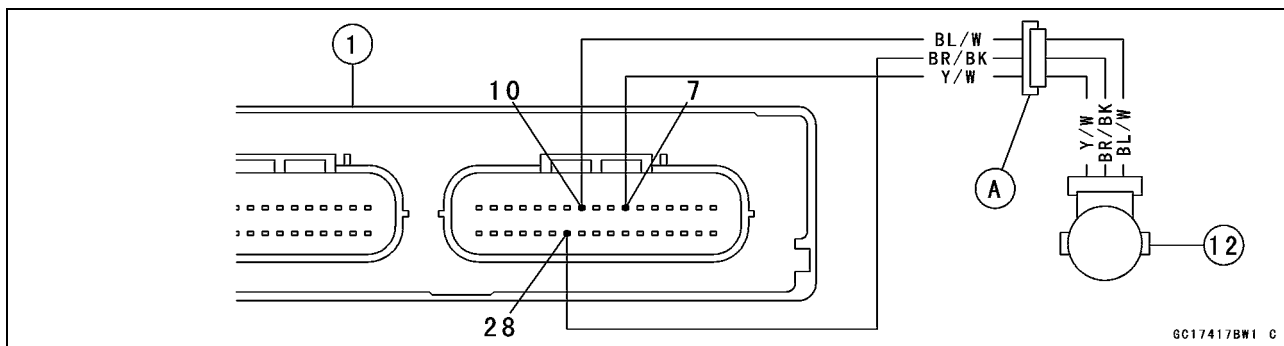
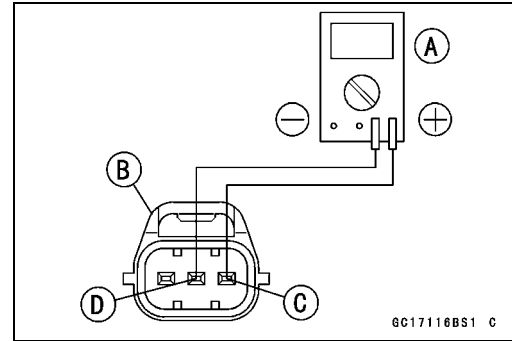

- 1. ECU
- 12. Main Throttle Sensor
- A. Throttle Body Assy Connector

Inlet Air Pressure Sensor (Service Code 12)

CAUTION

Never drop the sensor, especially on a hard surface. Such a shock to the part can damage it.

Removal

ZX1200-B1/B2

- Remove the left lower inner cover (see Frame chapter).
- Unscrew the inlet air pressure sensor bracket nut [A] to remove the air pressure sensor [B].

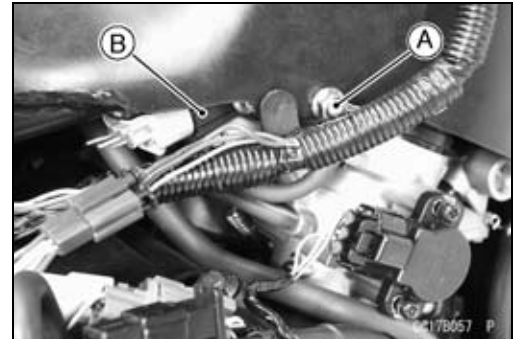

- Disconnect the inlet air pressure sensor connector [A].
- Disconnect the vacuum hose [B] from the joint.
- Remove the inlet air pressure sensor [C].



ZX1200-B3

- Remove the left lower inner cover (see Frame chapter).
- Unscrew the inlet air pressure sensor bracket nut [A] to remove the inlet air pressure sensor [B].

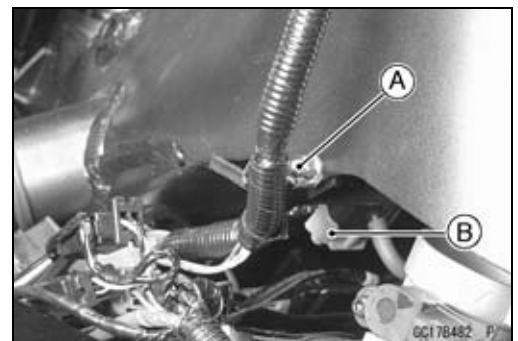

- Disconnect the inlet air pressure sensor connector [A].
- Disconnect the vacuum hose [B] from the joint.
- Remove the inlet air pressure sensor [C].

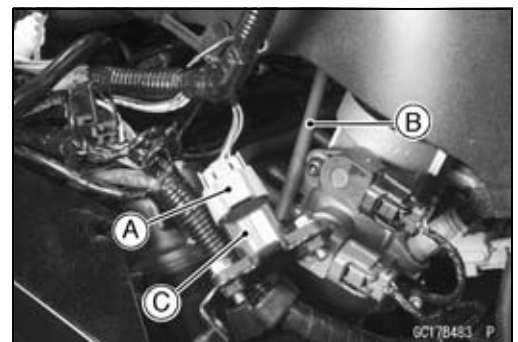

3-76 FUEL SYSTEM (DFI)

Inlet Air Pressure Sensor (Service Code 12)

Installation

CAUTION

Do not connect the throttle sensor connector to the inlet air pressure sensor, because the pressure sensor is broken by the opposite electrical connection.

NOTE

○The inlet air pressure sensor is the same part as the atmospheric sensor except that the sensor has a vacuum hose and different wiring.

- Route the vacuum hose correctly (see Cable, Wire, and Hose Routing section in General Information chapter). Make sure they do not get pinched or kinked.

- Install:

Inlet Air Pressure Sensor [A]

Frame Ground [B]

- Hit the stopper [C] of the inlet air pressure sensor bracket onto the frame [D].

Torque - Inlet Air Pressure Sensor Bolts: 12 N·m (1.2 kgf·m, 106 in·lb)

Inlet Air Pressure Sensor Bracket Nut: 12 N·m (1.2 kgf·m, 106 in·lb)

Input Voltage Inspection

NOTE

○Be sure the battery is fully charged.

○The inspection is the same as "Input Voltage Inspection" of the throttle sensor and the atmospheric pressure sensor.

- Turn the ignition switch OFF.
- Remove the ECU (see this chapter). Do not disconnect the ECU connectors.
- Connect a digital voltmeter [A] to the connector [B], with the needle adapter set.
- Measure the input voltage with the engine stopped, and with the connectors joined.

Special Tool - Needle Adapter Set: 57001-1457

- Turn the ignition switch ON.

Inlet Air Pressure Sensor Input Voltage Connections to ECU

ZX1200-B1/B2:

Meter (+) → BL/W lead (terminal 41)

Meter (-) → BR/BK lead (terminal 54)

ZX1200-B3:

Meter (+) → BL/W lead (terminal 10)

Meter (-) → BR/BK lead (terminal 28)

Input Voltage at ECU

Standard: 4.75 ~ 5.25 V DC

- ★ If the reading is less than the standard range, check the ECU for its ground, and power supply (see this chapter). If the ground and power supply are good, replace the ECU.

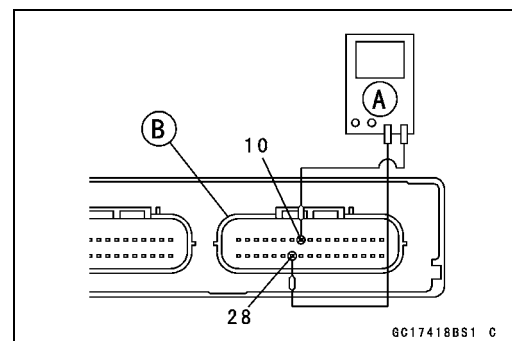
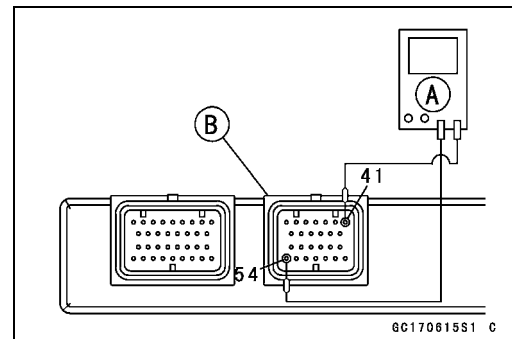
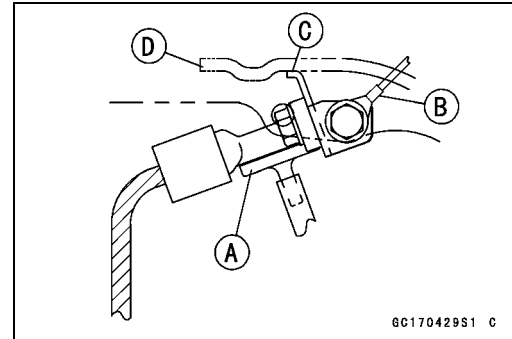

Inlet Air Pressure Sensor (Service Code 12)

★If the reading is within the standard range, and check the input voltage again at the sensor connector.

- Disconnect the inlet air pressure sensor connector and connect the harness adapter between the sub harness connector and inlet air pressure sensor connector.
- Connect a digital meter [A] to the harness adapter leads [B].

Special Tool - Throttle Sensor Harness Adapter #2: 57001-1408

- Measure the input voltage with the engine stopped.
- Turn the ignition switch ON.

Inlet Air Pressure Sensor Input Voltage

Connections to Sensor

Meter (+) → BL/W lead [C]

Meter (-) → BR/BK lead [D]

Input Voltage at Sensor Connector

Standard: 4.75 ~ 5.25 V DC

★If the reading is out of the standard range, check the wiring (see wiring diagram in this section).

★If the reading is good, the input voltage is normal. Check the output voltage.

Output Voltage Inspection

- Measure the output voltage at the ECU in the same way as input voltage inspection. Note the following.

Inlet Air Pressure Sensor Output Voltage

Connections to ECU

ZX1200-B1/B2:

Meter (+) → Y/BL lead (terminal 51)

Meter (-) → BR/BK lead (terminal 54)

ZX1200-B3:

Meter (+) → Y/BL lead (terminal 8)

Meter (-) → BR/BK lead (terminal 28)

Output Voltage at ECU

Usable Range: 3.46 ~ 3.82 V DC at the standard atmospheric pressure (101.32 kPa, 76 cmHg abs.)

NOTE

- The output voltage changes according to the local atmospheric pressure.
- The vacuum sensor output voltage is based on a nearly perfect vacuum in the small chamber of the sensor. So, the sensor indicates absolute vacuum pressure.

★If the output voltage is within the usable range, check the ECU for its ground, and power supply (see this chapter). If the ground and power supply are good, replace the ECU.

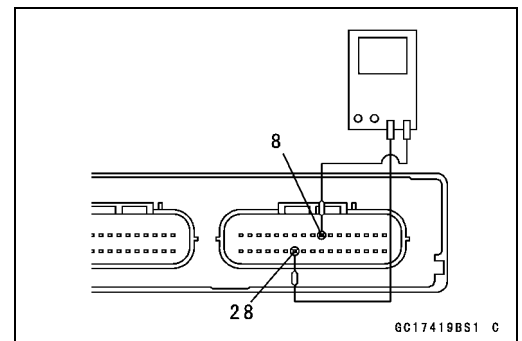
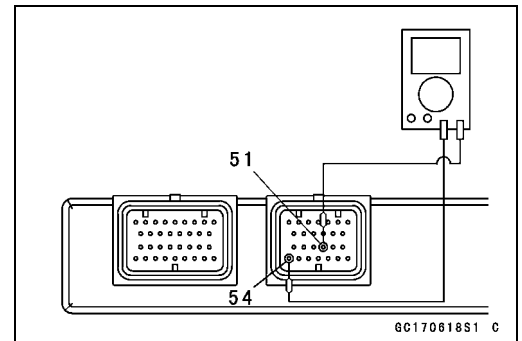
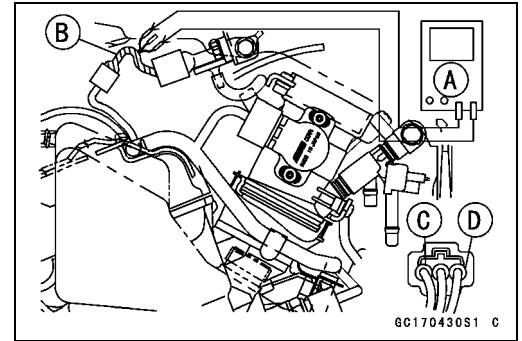

3-78 FUEL SYSTEM (DFI)

Inlet Air Pressure Sensor (Service Code 12)

- ★ If the output voltage is far out of the usable range, check the output voltage again at the sensor connector (when the lead is open, the output voltage is about 1.8 V).
- Connect a digital meter [A] to the harness adapter leads [B].

Special Tool - Throttle Sensor Harness Adapter #2: 57001-1408

Inlet Air Pressure Sensor Output Voltage Connections to Sensor

Meter (+) → Y/BL lead [C]

Meter (-) → BR/BK lead [D]

Output Voltage at Sensor Connector

Usable Range: 3.46 ~ 3.82 V DC at the standard atmospheric pressure (101.32 kPa or 76 cmHg absolute)

- ★ If the output voltage is normal, check the wiring for continuity (see next diagram).
- ★ If the output voltage is out of the usable range, replace the sensor.
- Turn the ignition switch OFF.
- Remove the throttle sensor harness adapter.

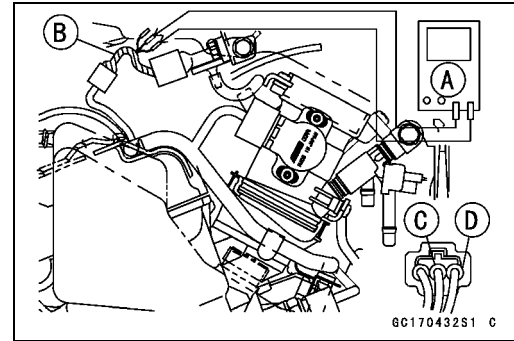

ZX1200-B1/B2

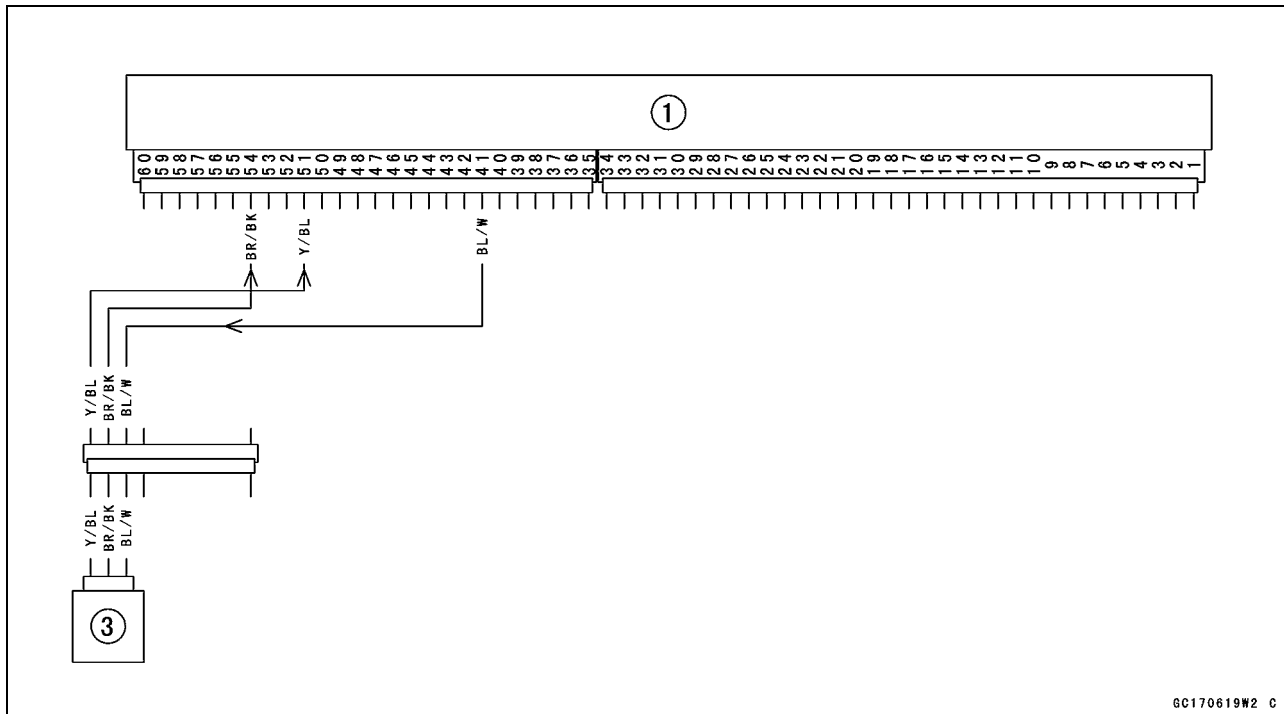

→: Signal

ECU [1]

Inlet Air Pressure Sensor [3]

Inlet Air Pressure Sensor (Service Code 12)

ZX1200-B3

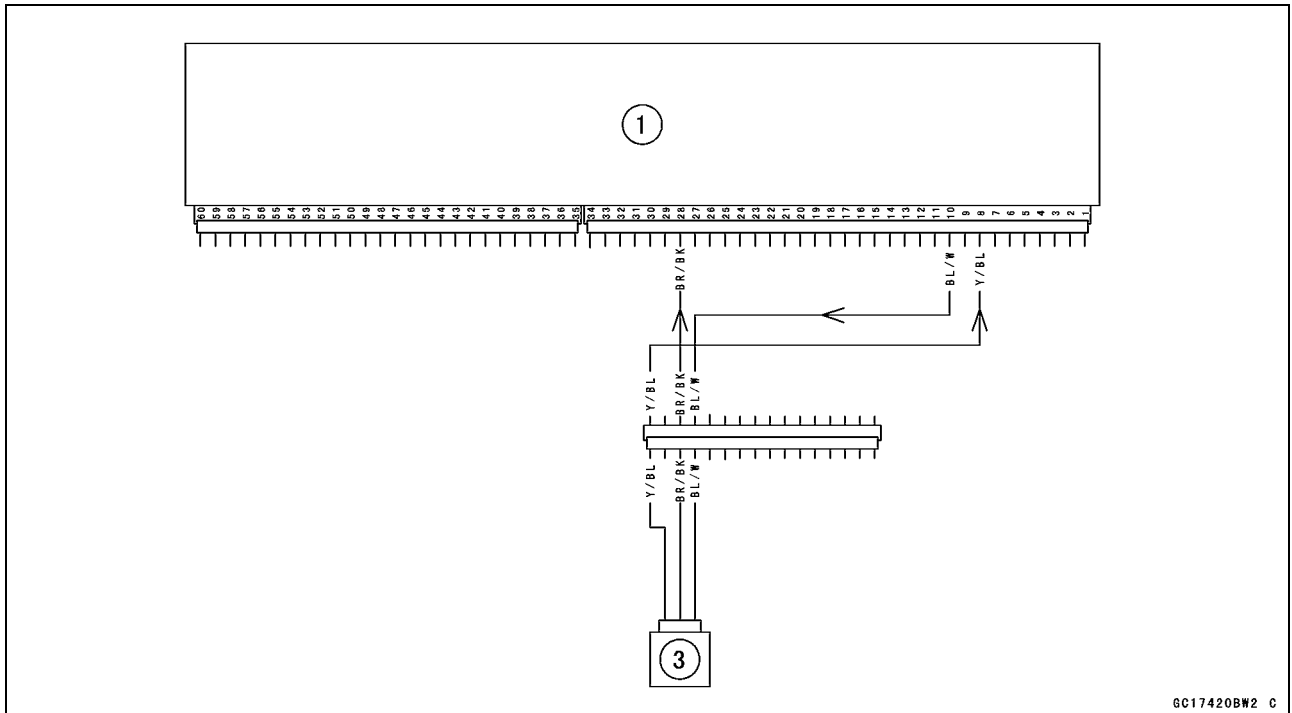

→: Signal

ECU [1]

Inlet Air Pressure Sensor [3]

★If you need to check the inlet air pressure sensor for vacuum other than 76 cmHg (abs), check the output voltage as follows:

- Remove the inlet air pressure sensor [A] and disconnect the vacuum hose from the sensor.
- Do not disconnect the sensor connector.
- Connect an auxiliary hose [B] to the inlet air pressure sensor.
- Temporarily install the inlet air pressure sensor.
- Connect a commercially available digital meter [C], vacuum gauge [D], and the fork oil level gauge [E] to the inlet air pressure sensor.

Special Tool - Fork Oil Level Gauge: 57001-1290

Digital Volt Meter Connections

Meter (+) → BL/W lead of Inlet Air Pressure Sensor

Meter (-) → BR/BK lead of Inlet Air Pressure Sensor

- Turn the ignition switch ON.
- Measure the inlet air pressure sensor output voltage from various vacuum readings, while pulling the handle of the fork oil level gauge.
- Check the inlet air pressure sensor output voltage, using the following formula and chart.

Suppose:

Pg : Vacuum Pressure (gauge) of Throttle Assy

PI : Local Atmospheric Pressure (absolute) measured by a barometer

Pv : Vacuum Pressure (absolute) of Throttle Assy

Vv : Sensor Output Voltage (v)

then

$$Pv = PI - Pg$$

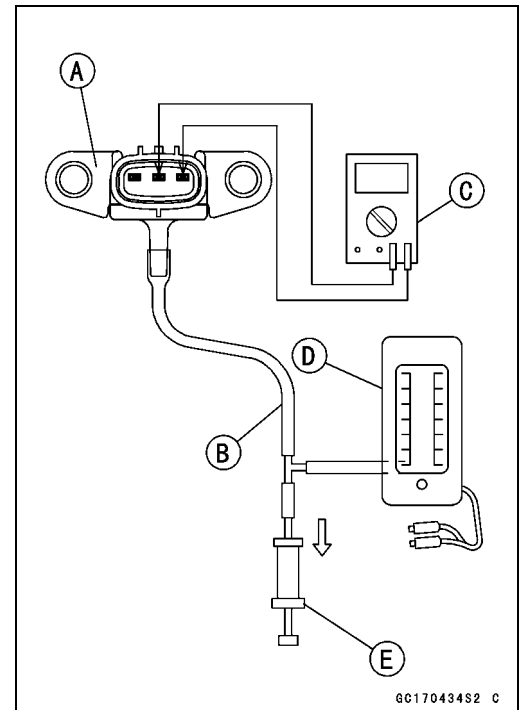

3-80 FUEL SYSTEM (DFI)

Inlet Air Pressure Sensor (Service Code 12)

For example, suppose the following data is obtained:

$P_g = 8$ cmHg (vacuum gauge reading)

$P_I = 70$ cmHg (barometer reading)

$V_v = 3.0$ V (digital volt meter reading)

then

$P_v = 70 - 8 = 62$ cmHg (abs)

Plot this P_v (62 cmHg) at a point [1] on the chart and draw a vertical line through the point. Then, you can get the usable range [2] of the sensor output voltage.

Usable range = 2.92 ~ 3.28 V

Plot V_v (3.0 V) on the vertical line. → Point [3].

Results: In the chart, V_v is within the usable range and the sensor is normal.

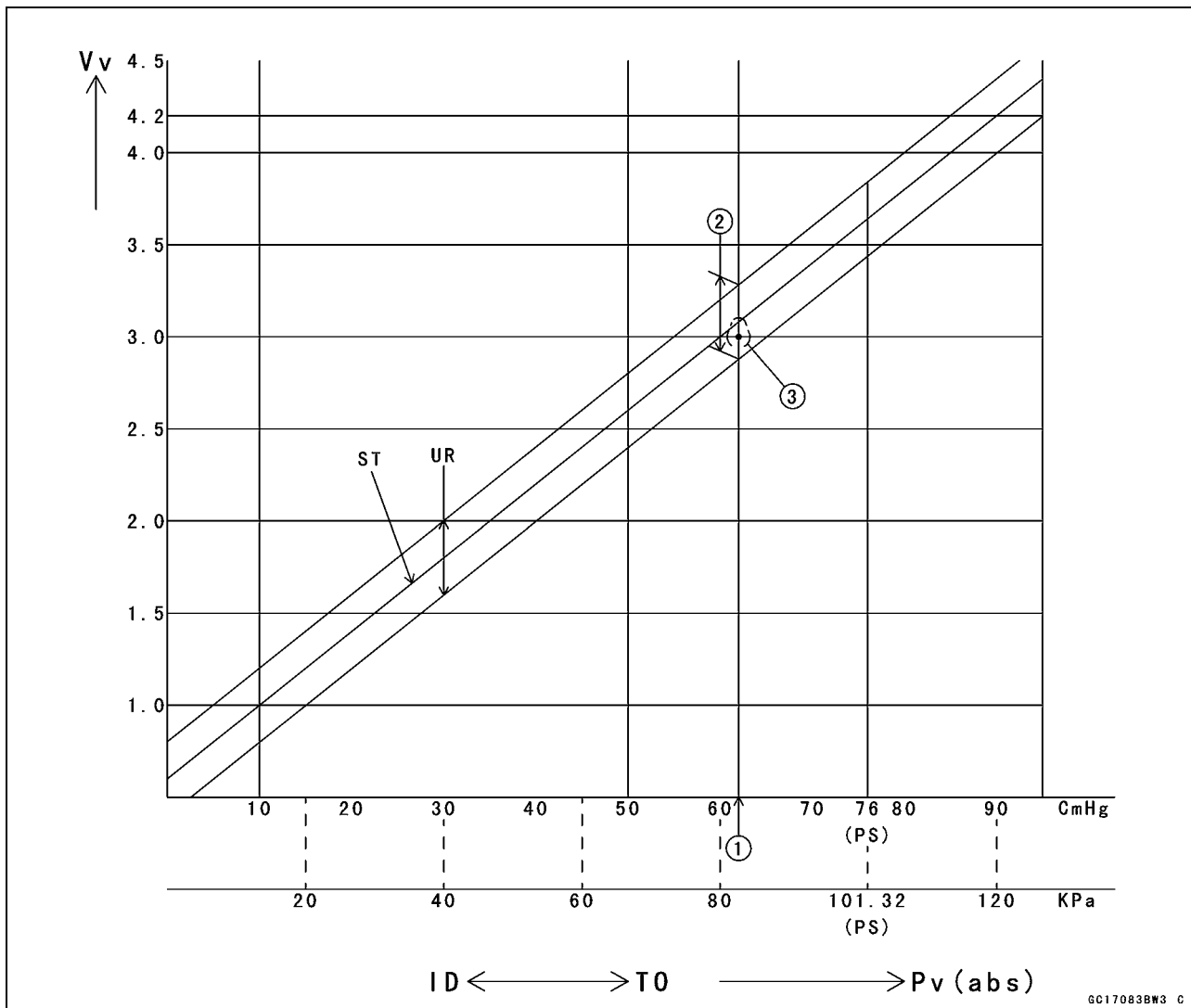

V_v : Inlet Air Pressure Sensor Output Voltage (V)(Digital Meter Reading)

P_v : Throttle Vacuum Pressure (absolute)

Ps: Standard Atmospheric Pressure (absolute)

ID: Idling

TO: Throttle Full Open

ST: Standard of Sensor Output Voltage (v)

UR: Usable Range of Sensor Output Voltage (v)

Inlet Air Temperature Sensor (Service Code 13)

Removal/Installation

CAUTION
Never drop the sensor, especially on a hard surface. Such a shock to the sensor can damage it.

- Remove the fuel tank cover (see Fuel Tank Removal).
 - Set up the fuel tank (see this chapter).
 - Disconnect the connector [A] from the inlet air temperature sensor.
 - Remove:
 - Bolts [B]
 - Damper [C]
 - Remove the inlet air temperature sensor [A].
- Torque - Inlet Air Temperature Sensor Nut: 7.8 N·m (0.80 kgf·m, 69 in·lb)**

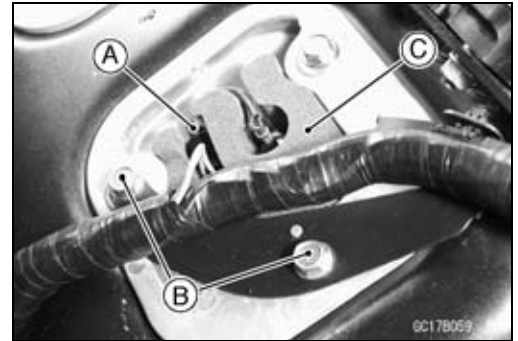

Output Voltage Inspection

NOTE

○Be sure the battery is fully charged.

- Remove the ECU (see this chapter). Do not disconnect the ECU connectors.
- Connect a digital voltmeter [A] to the ECU connector [B], using needle adapter set [C].

Special Tool - Needle Adapter Set: 57001-1457

- Measure the sensor output voltage with the engine stopped and the connector joined.
- Turn the ignition switch ON.

Inlet Air Temperature Sensor Output Voltage Connections to ECU Connector

ZX1200-B1/B2:

- Meter (+) → P lead (terminal 57)
- Meter (-) → BR/BK lead (terminal 54)

ZX1200-B3:

- Meter (+) → P lead (terminal 26)
- Meter (-) → BR/BK lead (terminal 28)

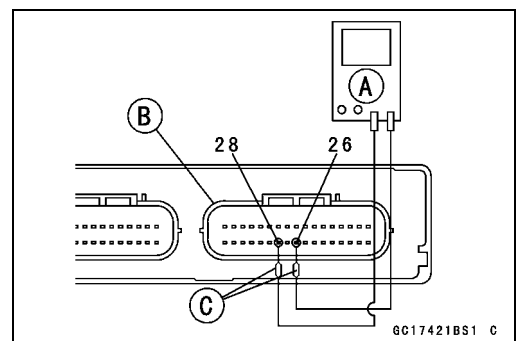
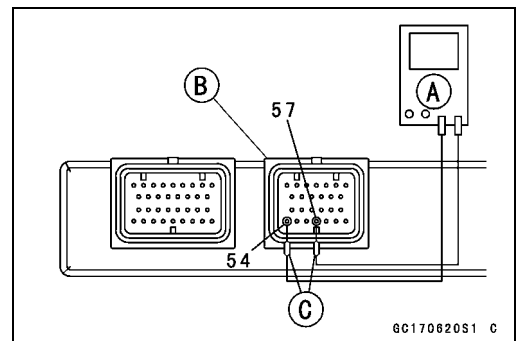

Output Voltage at ECU

Standard: about 2.26 ~ 2.50 V at inlet air temperature 20°C (68°F)

NOTE

○The output voltage changes according to the inlet air temperature.

- Turn the ignition switch OFF.

3-82 FUEL SYSTEM (DFI)

Inlet Air Temperature Sensor (Service Code 13)

- ★ If the output voltage is out of the specified, check the ECU for its ground, and power supply (see ECU section in this chapter). If the ground and power supply are good, replace the ECU.
- ★ If the output voltage is far out of the specified (e.g. when the wiring is open, the voltage is about 4.6 V), remove the fuel tank cover, and check the wiring (see next diagram).
- Remove the needle adapter set, and apply silicone sealant to the seals of the connector for waterproofing.

Silicone Sealant (Kawasaki Bond: 56019-120)

- Seals of ECU Connectors

- ★ If the wiring is good, check the sensor resistance.

Sensor Resistance Inspection

- Remove the inlet air temperature sensor (see this section).
- Suspend the sensor [A] in a container of machine oil so that the heat-sensitive portion and threaded portion are submerged.
- Suspend a thermometer [B] with the heat-sensitive portion [C] located in almost the same depth with the sensor.

NOTE

- *The sensor and thermometer must not touch the container side or bottom.*
- Place the container over a source of heat and gradually raise the temperature of the oil while stirring the oil gently for even temperature.
- Using a digital meter, measure the internal resistance of the sensor across the terminals at the temperatures shown in the table.

Inlet Air Temperature Sensor Resistance

Standard:	657 ~ 1 003 k Ω at 0°C (32°F)
	68 ~ 89 k Ω at 50°C (122°F)
	11.95 ~ 14.37 k Ω at 100°C (212°F)

- ★ If the measurement is out of the range, replace the sensor.
- ★ If the measurement is within the specified, replace the ECU.

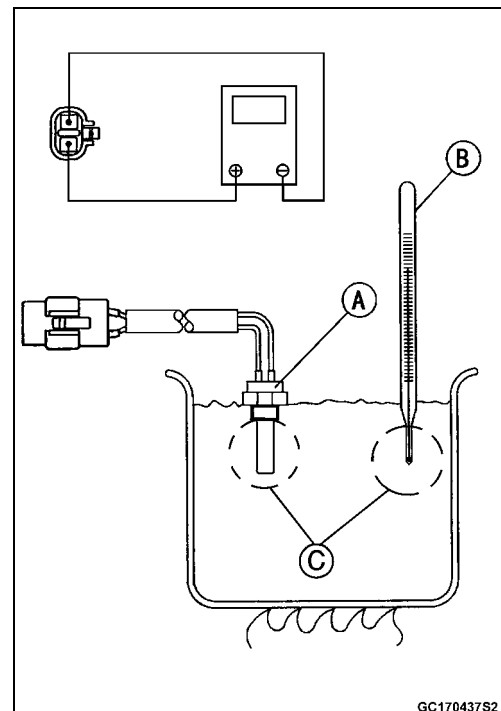

GC170437S2

Inlet Air Temperature Sensor (Service Code 13)

ZX1200-B1/B2

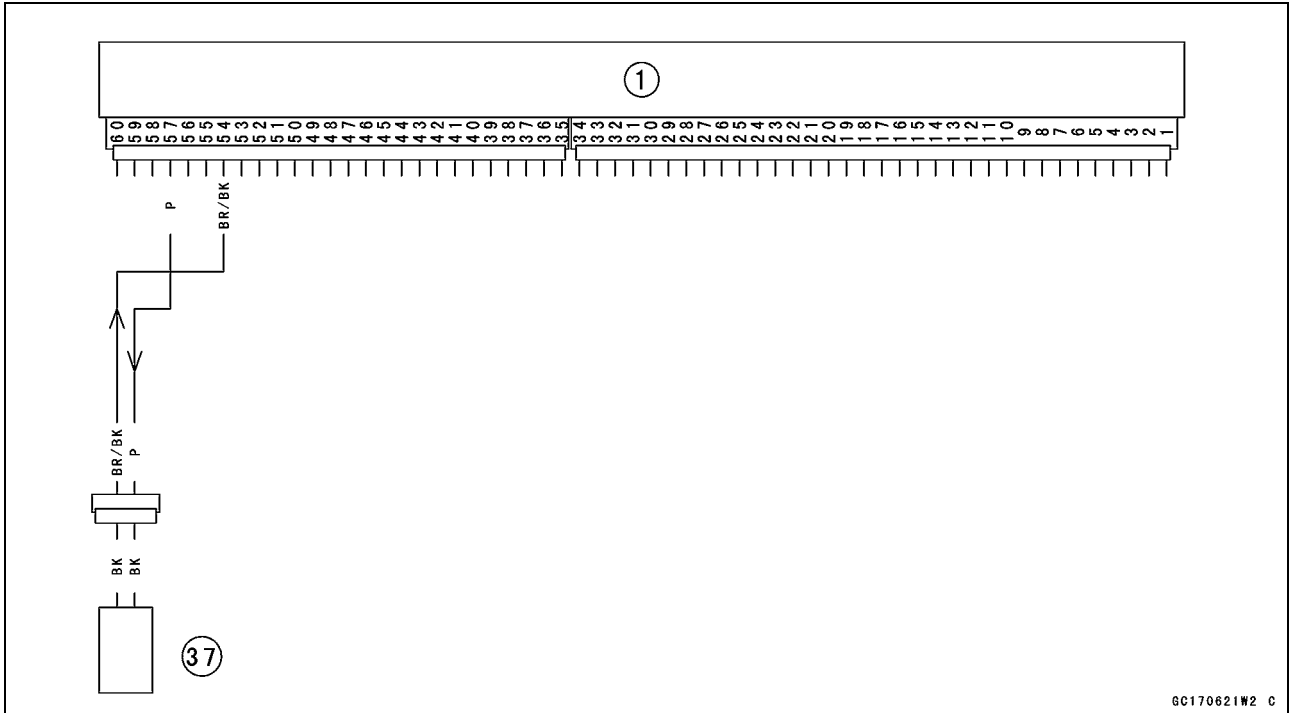

GC170621W2 C

→: Signal

ECU [1]

Inlet Air Temperature Sensor [37]

ZX1200-B3

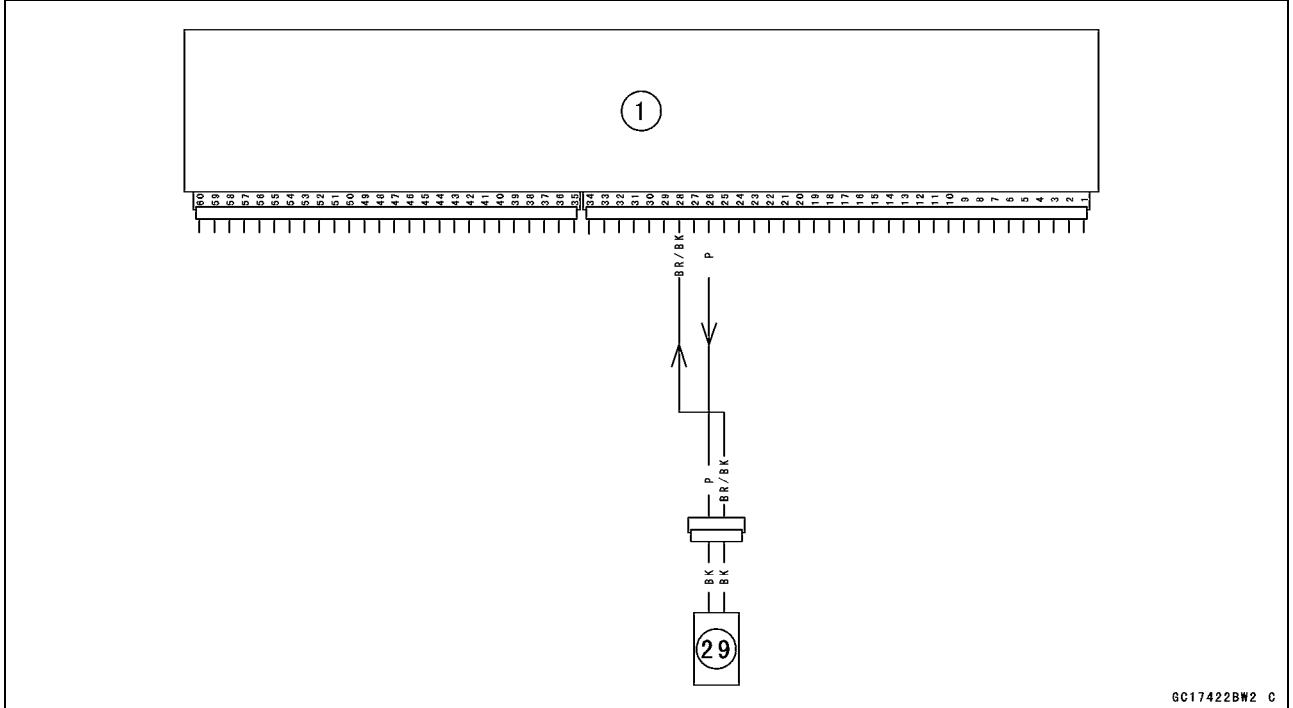

GC17422BW2 C

→: Signal

ECU [1]

Inlet Air Temperature Sensor [29]

3-84 FUEL SYSTEM (DFI)

Water Temperature Sensor (Service Code 14)

Removal/Installation

CAUTION

Never drop the sensor, especially on a hard surface. Such a shock to the sensor can damage it.

- Disconnect the sensor connector [A], and unscrew the water temperature sensor [B].

Silicone Sealant (Kawasaki Bond: 56019-120)

- Threads of Water Temperature Sensor

Torque - Water Temperature Sensor: 18 N·m (1.8 kgf·m, 13 ft·lb)

- Fill the engine with coolant and bleed the air from the cooling system (see Coolant Filling in the Cooling System chapter).

Output Voltage Inspection

NOTE

○Be sure the battery is fully charged.

- Remove the ECU (see this chapter). Do not disconnect the connectors.
- Connect a digital voltmeter [A] to the ECU connector [B], with the needle adapter set [C].

Special Tool - Needle Adapter Set: 57001-1457

- Measure the sensor output voltage with the engine stopped and the connector joined.
- Turn the ignition switch ON.

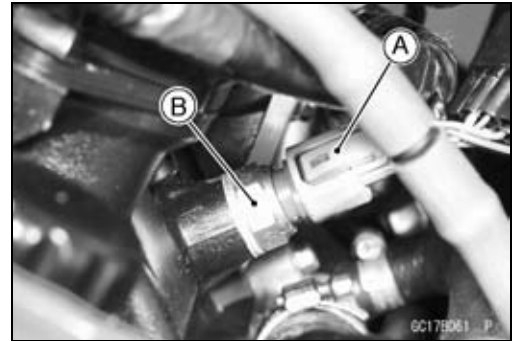

Water Temperature Sensor (Service Code 14)

Water Temperature Sensor Output Voltage Connections to ECU

ZX1200-B1/B2:

- Meter (+) → O lead (terminal 58)
- Meter (-) → BR/BK lead (terminal 54)

ZX1200-B3:

- Meter (+) → O lead (terminal 9)
- Meter (-) → BR/BK lead (terminal 28)

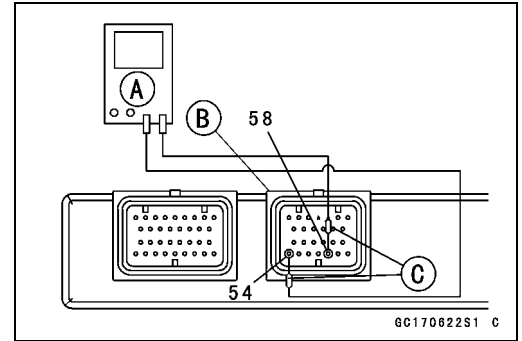

Output Voltage at ECU

Standard: about 1.95 ~ 2.29 V at 20°C (68°F)

NOTE

○ The output voltage changes according to the coolant temperature in the engine.

- Turn the ignition switch OFF.
- ★ If the output voltage is out of the specified, check the ECU for its ground, and power supply (see this chapter). If the ground and power supply are good, replace the ECU.
- ★ If the output voltage is far out of the specified (e.g. when the wiring is open, the voltage is about 5V), check the wiring (see next diagram).
- ★ If the wiring is good, check the water temperature sensor resistance.
- Remove the needle adapter set, and apply silicone sealant to the seals of the connector for waterproofing.

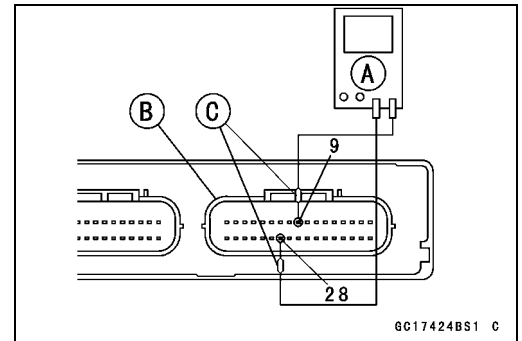

Silicone Sealant (Kawasaki Bond: 56019-120)

- Seals of ECU Connectors

ZX1200-B1/B2

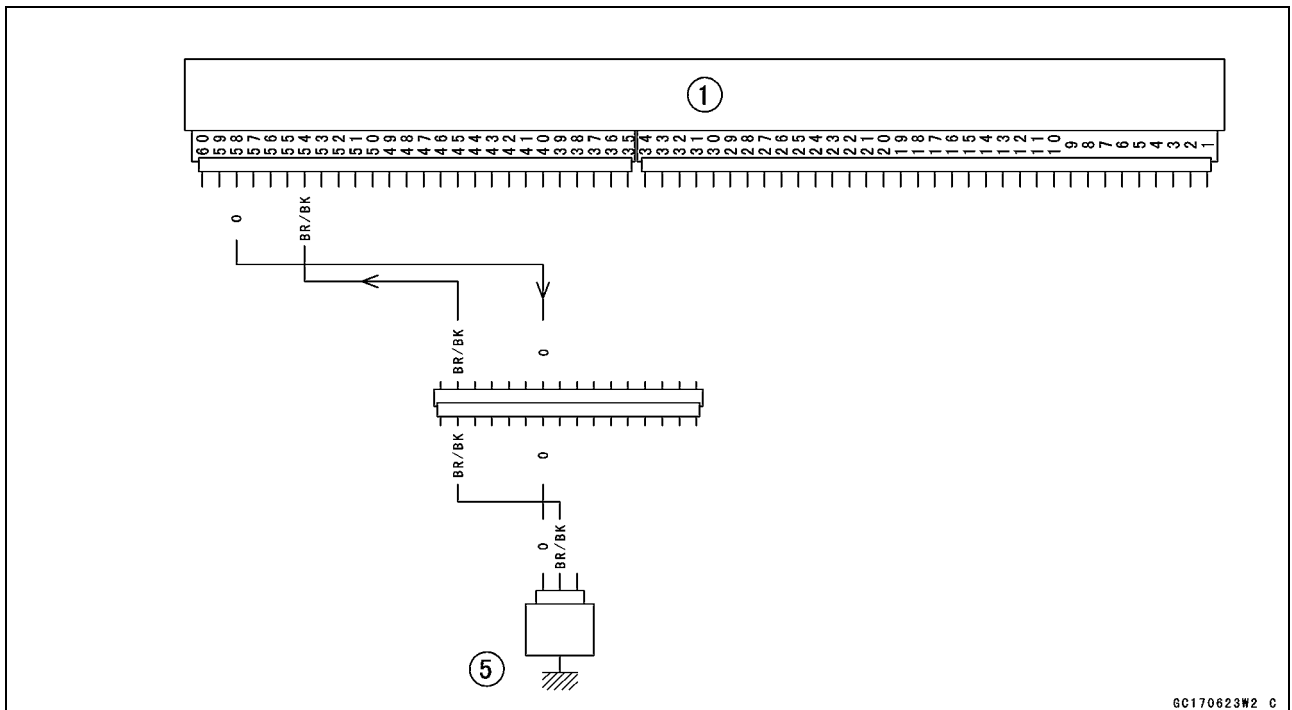

→: Signal

ECU [1]

Water Temperature Sensor [5]

3-86 FUEL SYSTEM (DFI)

Water Temperature Sensor (Service Code 14)

ZX1200-B3

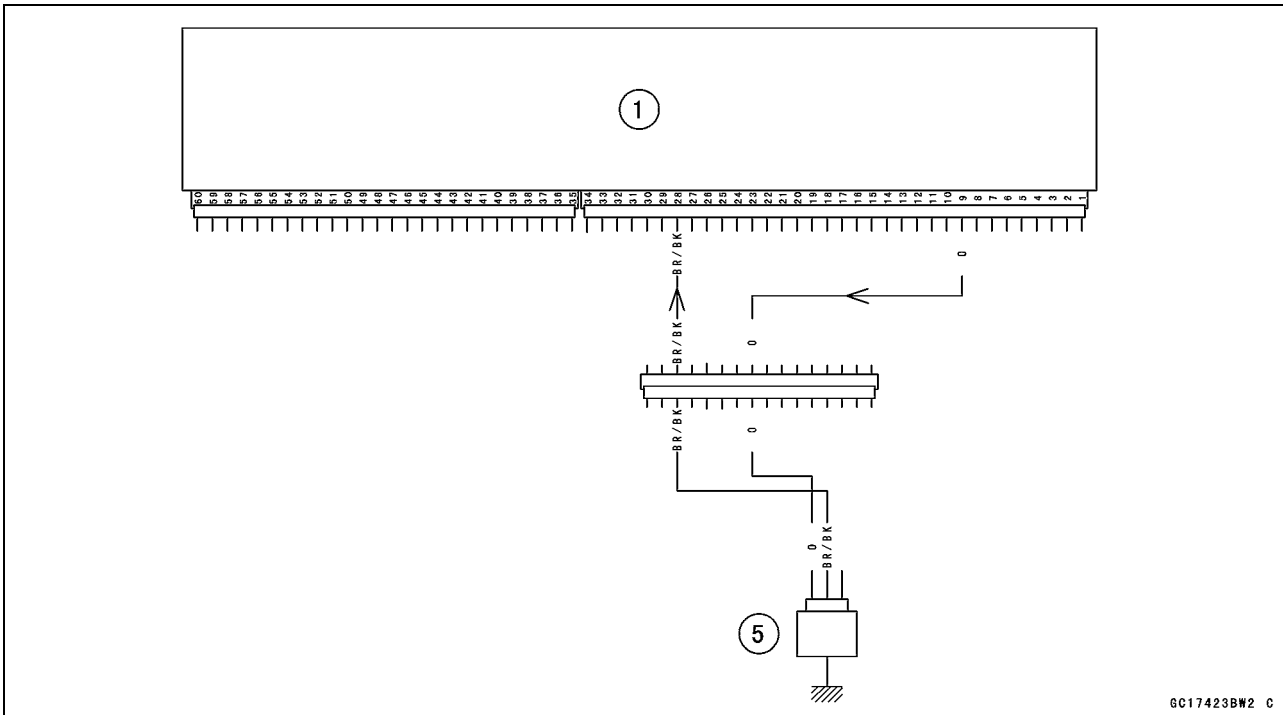

GC17423BW2 C

→: Signal

ECU [1]

Water Temperature Sensor [5]

Sensor Resistance Inspection

- Remove the water temperature sensor (see this section).
- Refer to the Electrical System chapter for water temperature sensor inspection.

Atmospheric Pressure Sensor (Service Code 15)

CAUTION

Never drop the sensor, especially on a hard surface. Such a shock to the sensor can damage it.

Removal

- Turn the ignition switch off.
- Remove:
 - Seat Cover (see Frame chapter)
 - Bolts [A]
- Remove the atmospheric pressure sensor [B].
- Disconnect the sensor connectors [C].

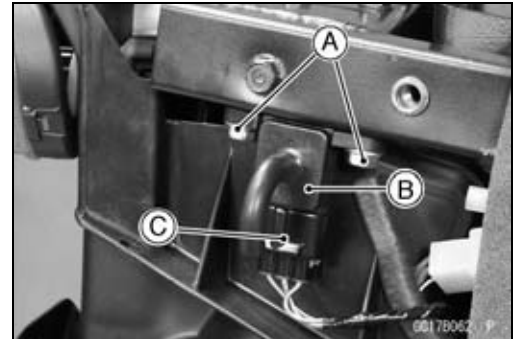

Installation

- Installation is reverse of removal.
- Tighten the sensor bolts.

Torque - Atmospheric Pressure Sensor Bolts: 12 N·m (1.2 kgf·m, 106 in·lb)

NOTE

○The atmospheric pressure sensor is the same part as the inlet air pressure sensor except that the inlet air pressure sensor has a inlet air pressure hose and different wiring.

Input Voltage Inspection

NOTE

○Be sure the battery is fully charged.
 ○The inspection is the same as "Input Voltage Inspection" of the throttle sensor and the inlet air pressure sensor.

- Turn the ignition switch OFF.
 - Remove the ECU (see this chapter). Do not disconnect the ECU connectors.
 - Connect a digital voltmeter [A] to the connector [B], with the needle adapter set.
- Measure the input voltage with the engine stopped, and with the connectors joined.

Special Tool - Needle Adapter Set: 57001-1457

- Turn the ignition switch ON.

Atmospheric Pressure Sensor Input Voltage Connections to ECU

ZX1200-B1/B2:

- Meter (+) → BL/W lead (terminal 41)
- Meter (-) → BR/BK lead (terminal 54)

ZX1200-B3:

- Meter (+) → BL/W lead (terminal 10)
- Meter (-) → BR/BK lead (terminal 28)

Input Voltage at ECU

Standard: 4.75 ~ 5.25 V DC

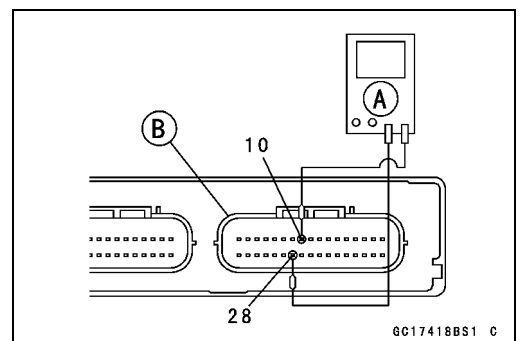
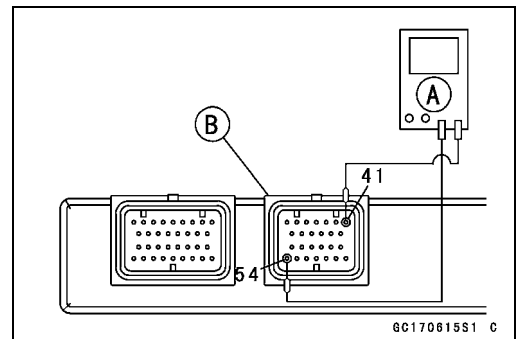

3-88 FUEL SYSTEM (DFI)

Atmospheric Pressure Sensor (Service Code 15)

★If the reading of input voltage is less than the standard range, check the ECU for its ground, and power supply (see this chapter). If the ground and power supply are good, replace the ECU.

★If the reading is within the standard range, remove the seat cover, and check the input voltage again at the sensor connector.

- Disconnect the atmospheric pressure sensor connector and connect the harness adapter between the main harness connector and pressure sensor connector.
- Connect a digital meter [A] to the harness adapter leads [B].

Special Tool - Throttle Sensor Harness Adapter #2: 57001-1408

- Measure the input voltage with the engine stopped, and with the connector joined.
- Turn the ignition switch ON.

Atmospheric Pressure Sensor Input Voltage

Connections to Sensor

Meter (+) → BL/W lead [C]

Meter (-) → BR/BK lead [D]

Input Voltage at Sensor Connector

Standard: 4.75 ~ 5.25 V DC

★If the reading is out of the standard range, check the wiring (see wiring diagram in this section).

★If the reading is good, the input voltage is normal. Check the output voltage.

- Turn the ignition switch OFF.

Output Voltage Inspection

- Measure the output voltage at the ECU in the same way as input voltage inspection. Note the following.

Digital Meter [A]

ECU Connector [B]

Needle Adapter Set [C]

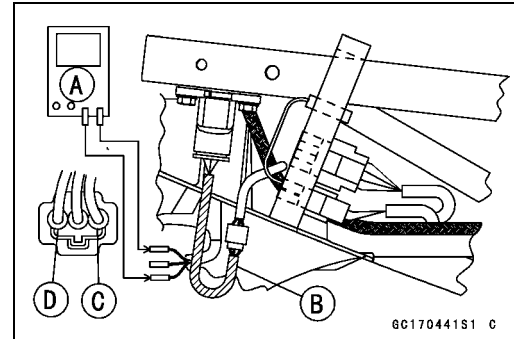

Atmospheric Pressure Sensor (Service Code 15)

Atmospheric Pressure Sensor Output Voltage
Connections to ECU

ZX1200-B1/B2:

Meter (+) → G/W lead (terminal 45)

Meter (-) → BR/BK lead (terminal 54)

ZX1200-B3:

Meter (+) → G/W lead (terminal 25)

Meter (-) → BR/BK lead (terminal 28)

Usable Range: 3.46 ~ 3.82 V DC at the standard atmospheric pressure (101.32 kPa, 76 cmHg abs.)

NOTE

- The output voltage changes according to the local atmospheric pressure.
- The atmospheric sensor output voltage is based on a nearly perfect vacuum in the small chamber of the sensor. So, the sensor indicates absolute atmospheric pressure.

★ If the output voltage is within the usable range, check the ECU for its ground, and power supply (see this chapter). If the ground and power supply are good, replace the ECU.

★ If the output voltage is far out of the usable range, remove the fuel tank, and check the output voltage at the sensor connector (when the wiring is open, the output voltage is about 1.8 V).

- Connect a digital meter [A] to the harness adapter leads [B].

Special Tool - Throttle Sensor Harness Adapter #2: 57001-1408

Atmospheric Pressure Sensor Output Voltage
Connections to Sensor

Meter (+) → G/W lead [C]

Meter (-) → BR/BK lead [D]

Output Voltage at Sensor

Usable Range: 3.46 ~ 3.82 V DC at the standard atmospheric pressure (101.32 kPa, 76 cmHg abs)

★ If the output voltage is normal, check the wiring for continuity (see next diagram).

★ If the output voltage is out of the usable range, replace the sensor.

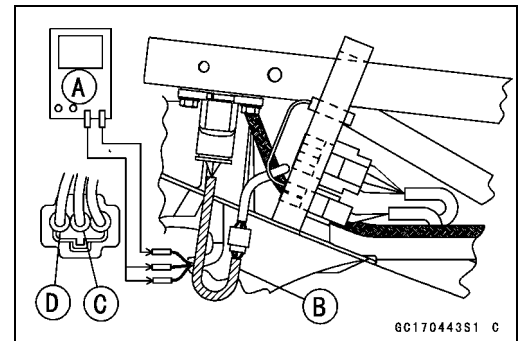
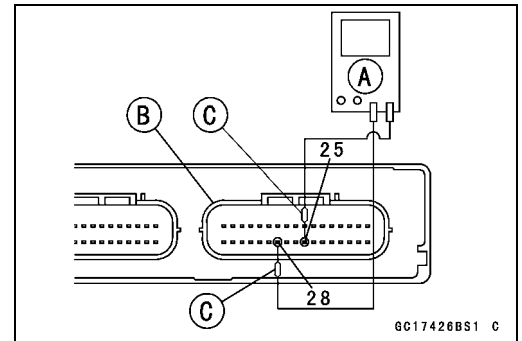
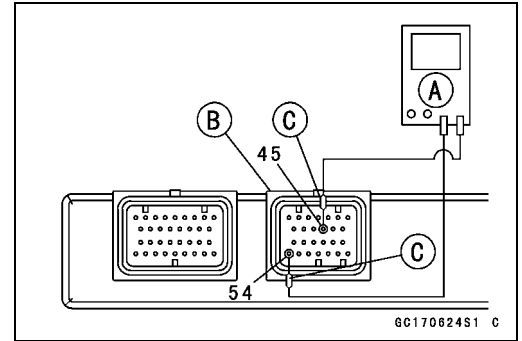

3-90 FUEL SYSTEM (DFI)

Atmospheric Pressure Sensor (Service Code 15)

ZX1200-B1/B2

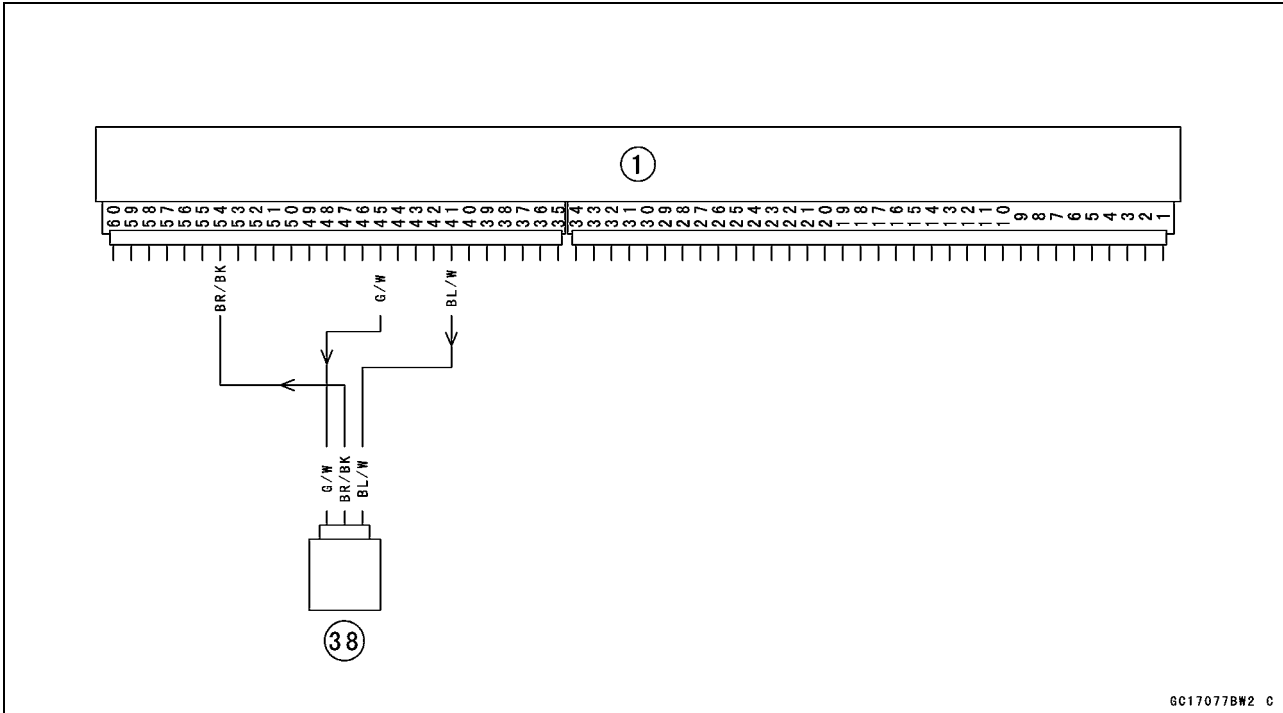

GC17077BW2 C

→: Signal

ECU [1]

Atmospheric Pressure Sensor [38]

ZX1200-B3

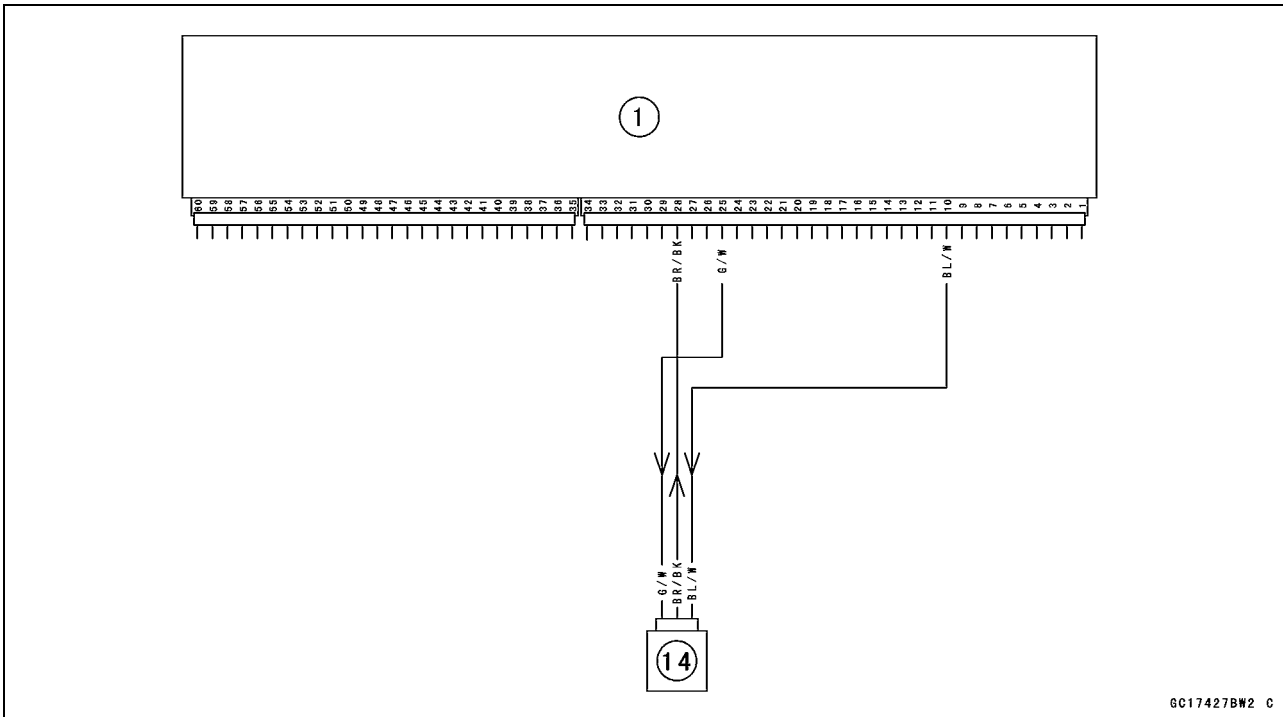

GC17427BW2 C

→: Signal

ECU [1]

Atmospheric Pressure Sensor [14]

★ If you need to check the atmospheric pressure sensor for various altitudes other than sea level, check the output voltage as follows:

○ Determine the local altitude (elevation).

Atmospheric Pressure Sensor (Service Code 15)

★If you know the local atmospheric pressure using a barometer, substitute the atmospheric pressure for throttle vacuum pressure in the inlet air pressure sensor chart (see Inlet Air Pressure Sensor section in this chapter). And get the usable range of the atmospheric pressure sensor output voltage and check if output voltage is within the standard or not in the same way as Output Voltage Inspection of the inlet air pressure sensor. If you know the local altitude, use the following chart.

Atmospheric Pressure/Altitude Relationship

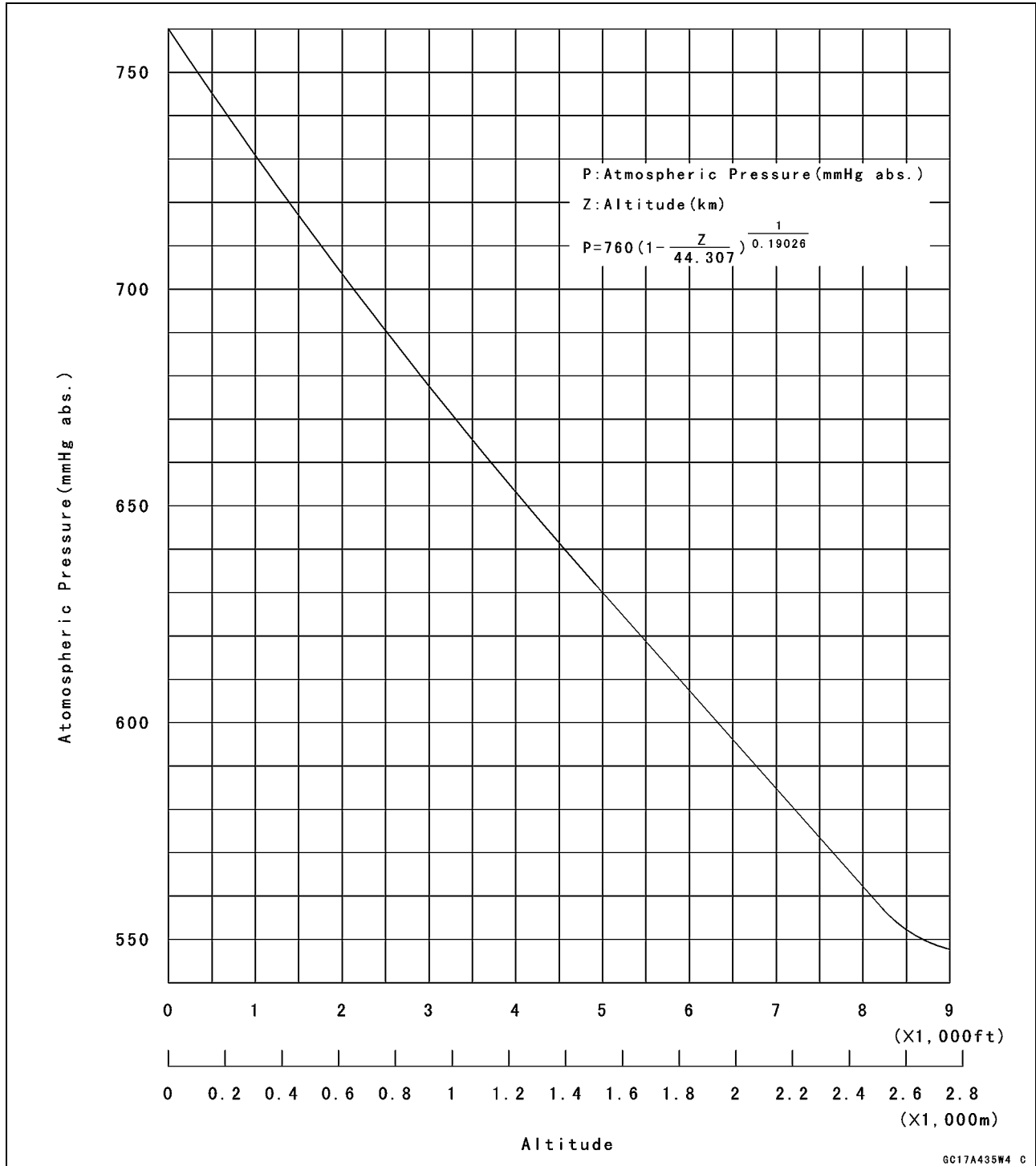

3-92 FUEL SYSTEM (DFI)

Crankshaft Sensor (Service Code 21)

Start the engine and switch the diagnosis mode to Dealer 1 mode to know all the problem that the DFI system has at the time of self-diagnosis. If the engine cannot be started, the self-diagnosis system does not detect dynamic condition of the crankshaft sensor. In this case turn off the ignition switch and turn it on again to enter the Dealer 2 mode. In this mode the system tells all the troubles which the DFI system had in both static and dynamic conditions.

Crankshaft Sensor Removal/Installation

- See the Ignition System section in the Electrical System chapter.

Crankshaft Sensor Inspection

- The crankshaft has no power source, and when the engine stops, the crankshaft generates no signals.
- Crank the engine and measure the peak voltage of the crankshaft sensor (see Electrical System chapter) in order to check the sensor.
- Check the wiring for continuity, using the following diagram.

ZX1200-B1/B2

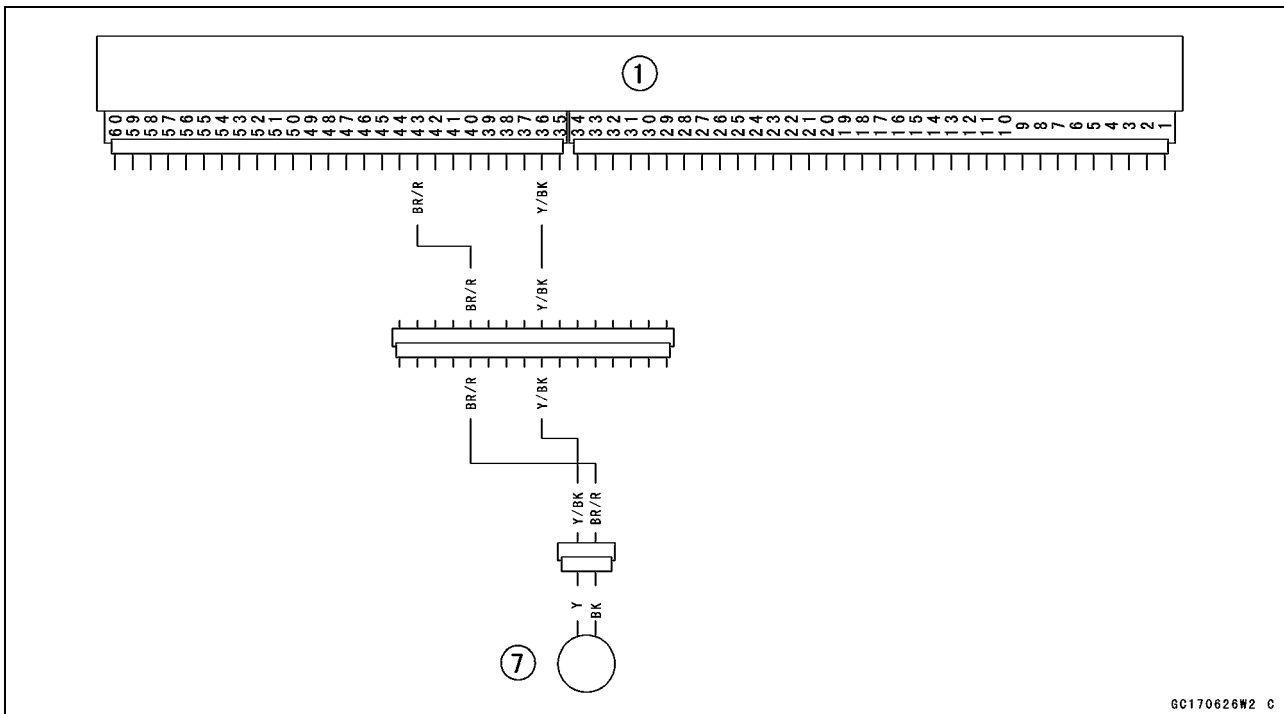

ECU [1]

Crankshaft Sensor [7]

Crankshaft Sensor (Service Code 21)

ZX1200-B3

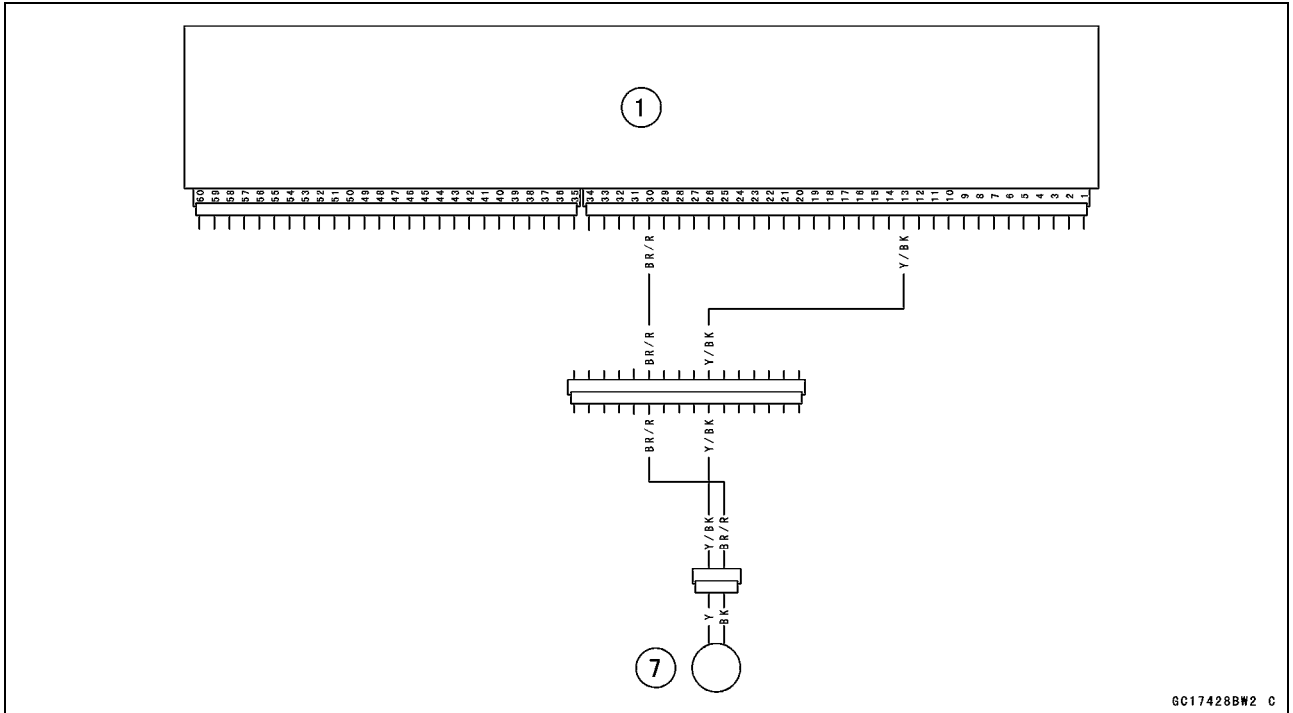

GC17428BW2 C

ECU [1]

Crankshaft Sensor [7]

3-94 FUEL SYSTEM (DFI)

Camshaft Position Sensor (Service Code 23)

Start the engine and switch the diagnosis mode to Dealer 1 mode to know all the problem that the DFI system has at the time of self-diagnosis. If the engine cannot be started, the self-diagnosis system does not detect dynamic condition of the camshaft position sensor. In this case turn off the ignition switch and turn it on again to enter the Dealer 2 mode. In this mode the system tells all the troubles which the DFI system had in both static and dynamic conditions.

Camshaft Position Sensor Removal/Installation

The camshaft position sensor detects the position of the camshaft, and distinguishes the cylinder.

- See the Ignition system section in the Electric System chapter.

Camshaft Position Sensor Inspection

- The camshaft position sensor have no power source, and when the engine stops, the camshaft position sensor generates no signal.
- Crank the engine and measure the peak voltage of the camshaft position sensor (see Electrical System chapter) in order to check the sensor.
- Check the wiring for continuity, using the following diagram.

ZX1200-B1/B2

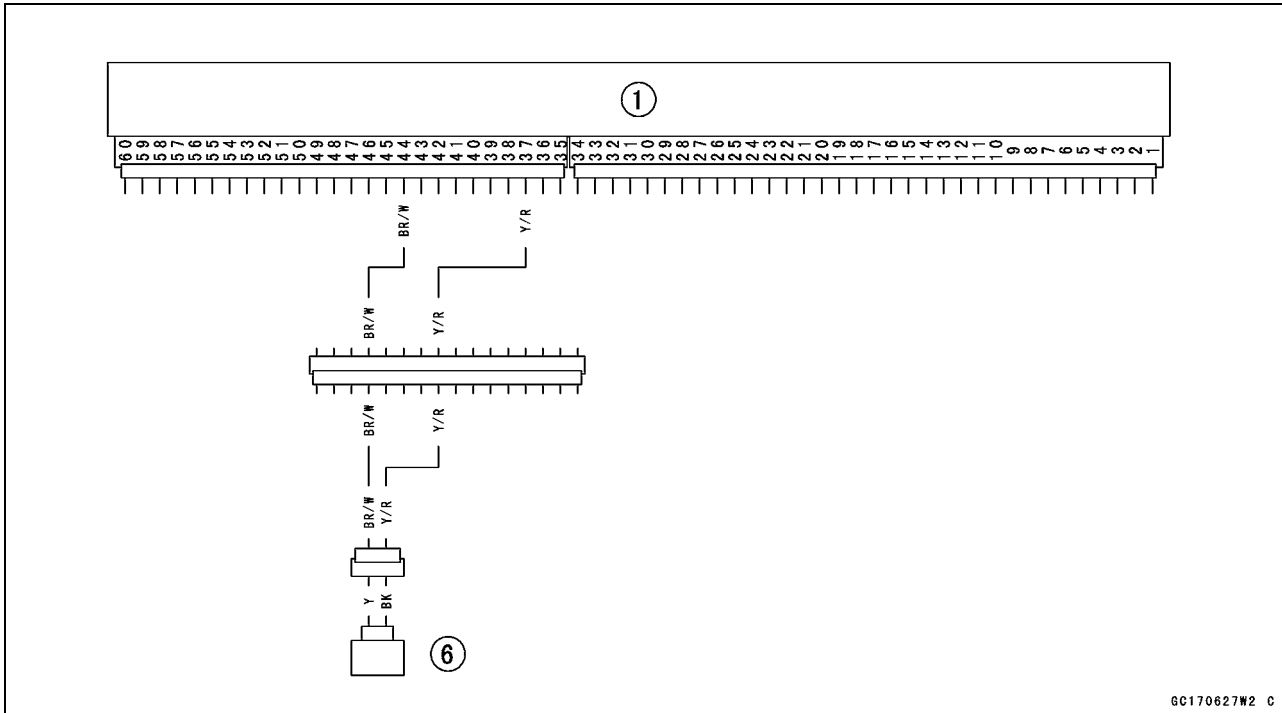

ECU [1]

Camshaft Position Sensor [6]

Camshaft Position Sensor (Service Code 23)

ZX1200-B3

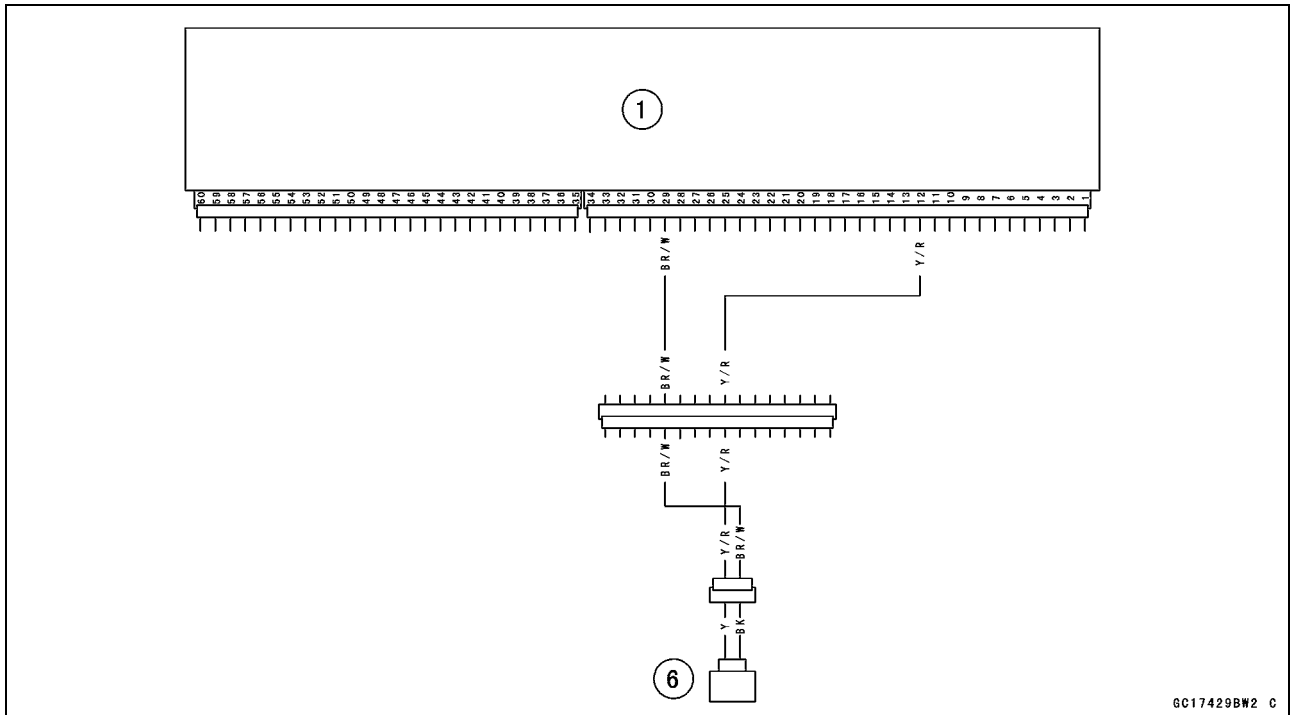

ECU [1]

Camshaft Position Sensor [6]

3-96 FUEL SYSTEM (DFI)

Speed Sensor (Service Code 24)

Speed Sensor Removal/Installation

- See the Electrical System.

Speed Sensor Inspection

- See the Electrical System chapter as to the Speed Sensor.

Torque - Speed Sensor Bolt: 10 N·m (1.0 kgf·m, 89 in·lb)

NOTE

○Be sure the battery is fully charged.

- Turn the ignition switch ON.
- Remove the ECU (see this chapter) not to disconnect the ECU connectors.
- Connect a digital voltmeter [A] leads to the connectors [B] [C] as follows, with the needle adapter set [D], and check the conductivity between them.

ZX1200-B1/B2:

Meter (+) → Y Lead (terminal 9)

Meter (-) → Y Lead (12P connector)

ZX1200-B3:

Meter (+) → Y Lead (terminal 11)

Meter (-) → Y Lead (12P connector)

Special Tool - Needle Adapter Set: 57001-1457

- ★ If there is not a conductivity between the connector and the ECU, check the speed sensor and wiring, or replace the sensor and/or ECU.

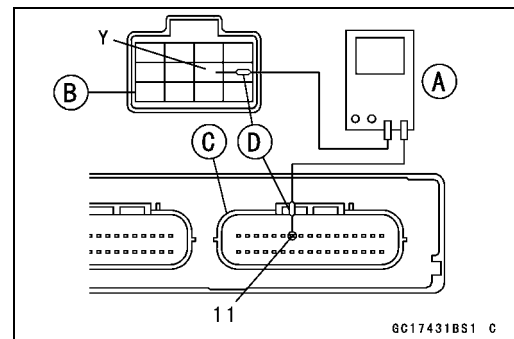
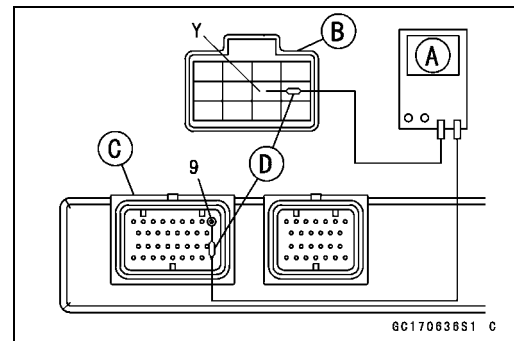

Speed Sensor (Service Code 24)

ZX1200-B1/B2

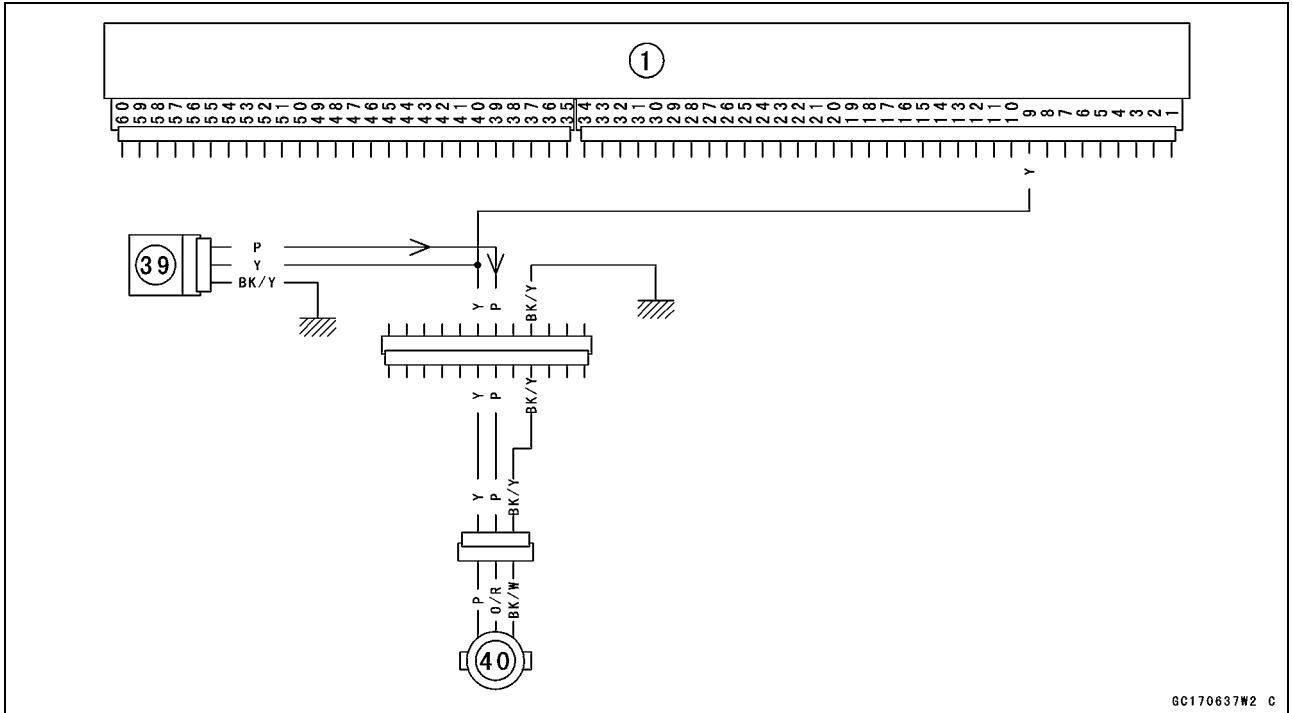

ECU [1]

Meter Assembly [39]

Speed Sensor [40]

ZX1200-B3

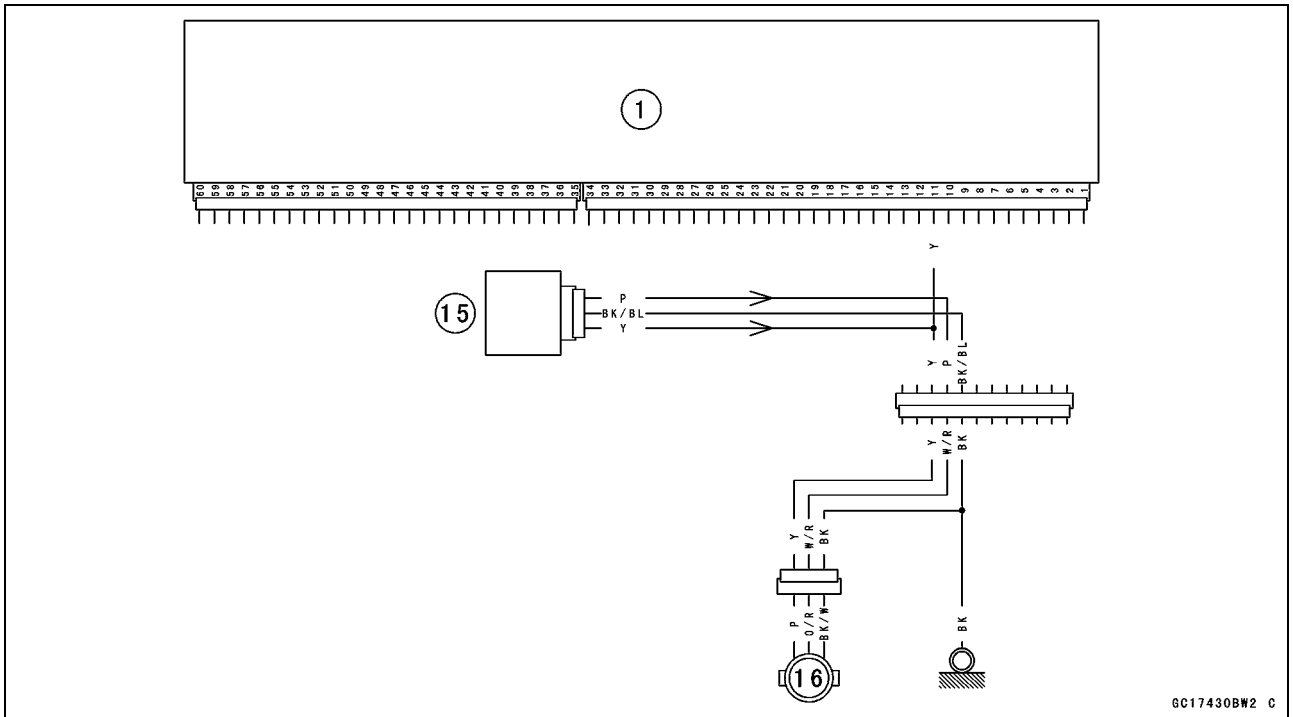

ECU [1]

Meter Assembly [15]

Speed Sensor [16]

3-98 FUEL SYSTEM (DFI)

Gear Position Switch (Service Code 25)

The gear position switch detects the gear position of the neutral and running, and sends the signal to the ECU.

The signal is used to determine the basic amount of the fuel injected.

Gear Position Switch Removal

- Remove:
 - Engine (see Engine Removal/Installation chapter)
- Open the clamp [A].
- Unscrew the screws [B] and remove the gear position switch, pin and spring.

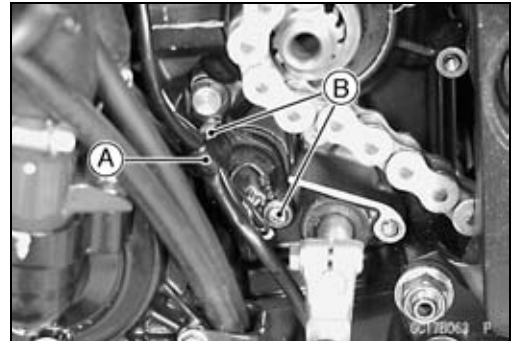

Gear Position Switch Installation

- Securely place the spring [A] and pin [B] into the hole [C] of the drum.
- Apply grease to the O-ring [D] and install the gear position switch.

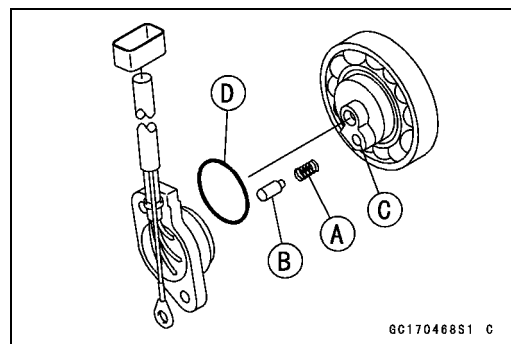

- Apply a non-permanent locking agent to the gear position switch screws and tighten them.
- Tighten the lower switch screw [A] with the ground terminal [B].

Torque - Gear Position Switch Screws: 4.0 N·m (0.40 kgf·m, 35 in·lb)

- Install the Engine (see Engine Removal/Installation chapter).

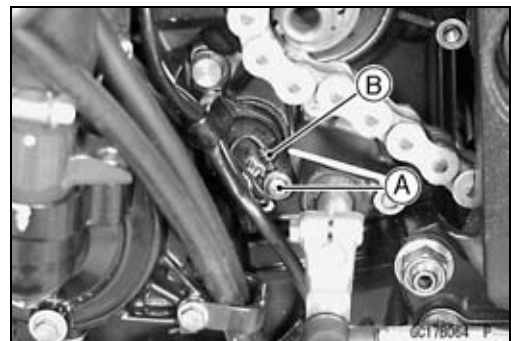

Gear Position Switch (Service Code 25)

Gear Position Switch Input Voltage Inspection

NOTE

○Be sure the battery is fully charged.

- Turn the ignition switch OFF.
- Remove the ECU (see this chapter). Do not disconnect the ECU connectors.
- Connect a digital voltmeter [A] to the connector [B], with the needle adapter set [C].
- Measure the input voltage with the engine stopped, and with the connectors joined.

Special Tool - Needle Adapter Set: 57001-1457

- Turn the ignition switch ON.

Gear Position Switch Input Voltage Connections to ECU ZX1200-B1/B2:

Gear Position	Tester (+)	Tester (-)
Neutral	Light Green Lead	20
1st	Green/Red Lead	47
2nd	Green/Blue Lead	53
3rd	Green/Yellow Lead	60
4th	Green Lead	46
5th	Green/White Lead	52
6th	Green/Black Lead	59
		Engine Ground

ZX1200-B3:

Gear Position	Tester (+)	Tester (-)
Neutral	Light Green Lead	55
1st	Green/Red Lead	37
2nd	Green/Blue Lead	36
3rd	Green/Yellow Lead	35
4th	Green Lead	50
5th	Green/White Lead	49
6th	Yellow/Green Lead	48
		Engine Ground

Input Voltage at ECU (Except gear position)

Standard: Neutral Battery Voltage (12.5 V or more) other than Neutral less than 5 V

Input Voltage at ECU (Respective Gear Position)

Standard: 0 V

★If the reading of input voltage is out of the standard range, check the ECU for its ground, and power supply (see this chapter). If the ground and power supply are good, replace the ECU.

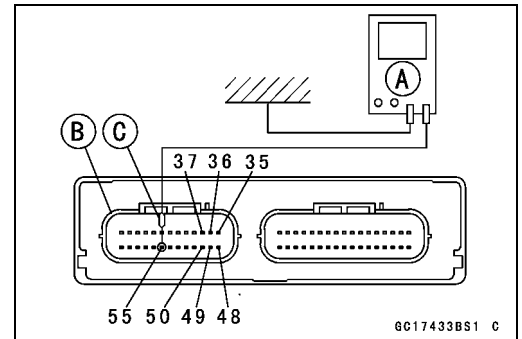
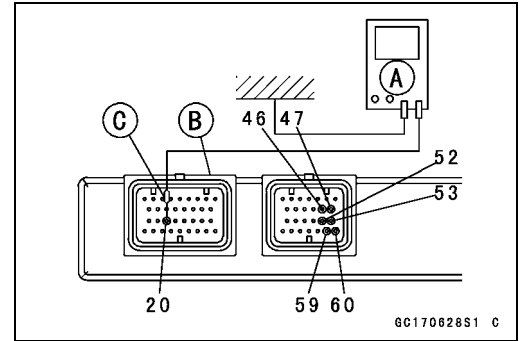

3-100 FUEL SYSTEM (DFI)

Gear Position Switch (Service Code 25)

★ If the reading is within the standard range, set up the fuel tank, and check the input voltage again at the sensor connector.

- Connect a digital voltmeter [H] to the connector [I], with the needle adapter set.
- Measure the input voltage with the engine stopped, and with the connector joined.

Special Tool - Needle Adapter Set: 57001-1457

- Turn the ignition switch ON.

Gear Position Switch Input Voltage Connection to ECU

Gear Position	Tester (+)	Tester (-)
Neutral	Light Green Lead [A]	Engine Ground
1st	Blue/Red Lead [B]	
2nd	Light Blue Lead [C]	
3rd	Red Lead [D]	
4th	Blue Lead [E]	
5th	Green/Red Lead [F]	
6th	Yellow/Green Lead [G]	

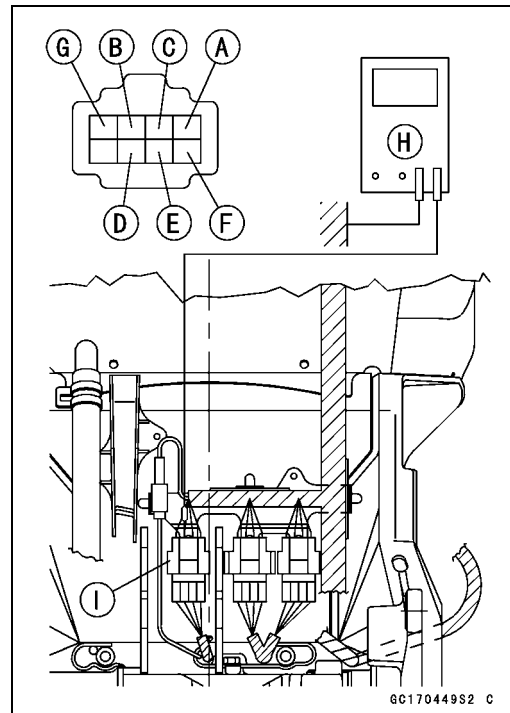

Input Voltage at Gear Position Switch Connector (Except Gear Position)

Standard: Neutral Battery Voltage (12.5 V or more) other than Neutral less than 5 V

Input Voltage at Gear Position Switch Connector (Respective Gear Position)

Standard: 0 V

- ★ If the reading is out of the standard range, check the wiring (see wiring diagram in this section).
- ★ If the reading is good, the input voltage is normal. Check the gear position switch.
- Turn the ignition switch OFF.
- Remove the needle adapter set.

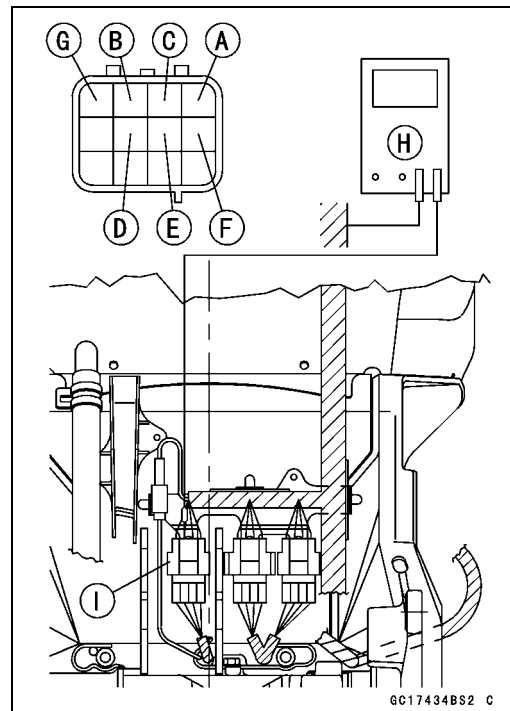

Gear Position Switch Inspection

- Set up the fuel tank.
- Disconnect the gear position switch connector [A].



Gear Position Switch (Service Code 25)

- Check the switch for continuity at the following gear positions.

Gear Position	Tester (+)	Tester (-)
Neutral	Light Green Lead [A]	Engine Ground [H]
1st	Blue/Red Lead [B]	
2nd	Light Blue Lead [C]	
3rd	Red Lead [D]	
4th	Blue Lead [E]	
5th	Green/Red Lead [F]	
6th	Yellow/Green Lead [G]	

- Black Lead [H]
- White/Red Lead [I]
- Yellow Lead [J]

- ★The switch is normal if there is continuity in the respective gear positions.
- ★If the switch has an open or short circuit, repair or replace it.

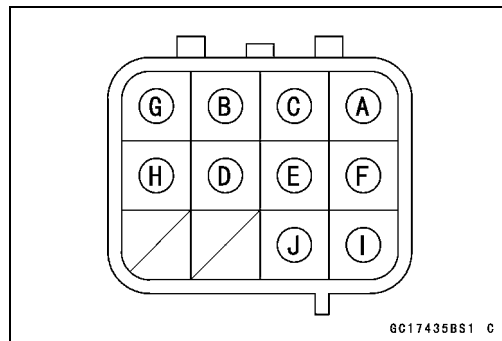
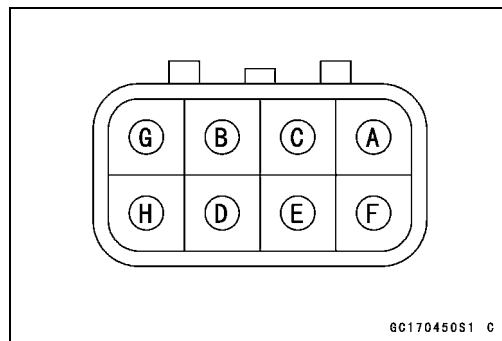

ZX1200-B1/B2

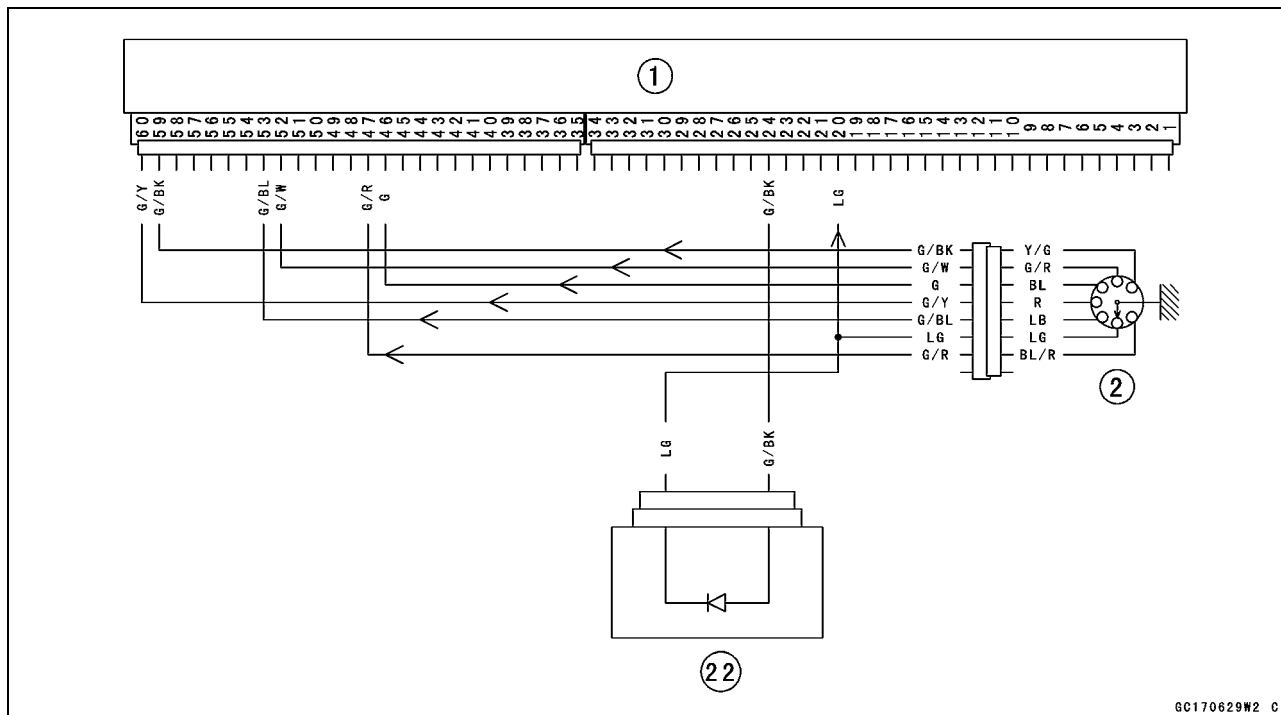

→: Signal
ECU [1]

Gear Position Switch [2]
Junction Box [22]

3-102 FUEL SYSTEM (DFI)

Gear Position Switch (Service Code 25)

ZX1200-B3

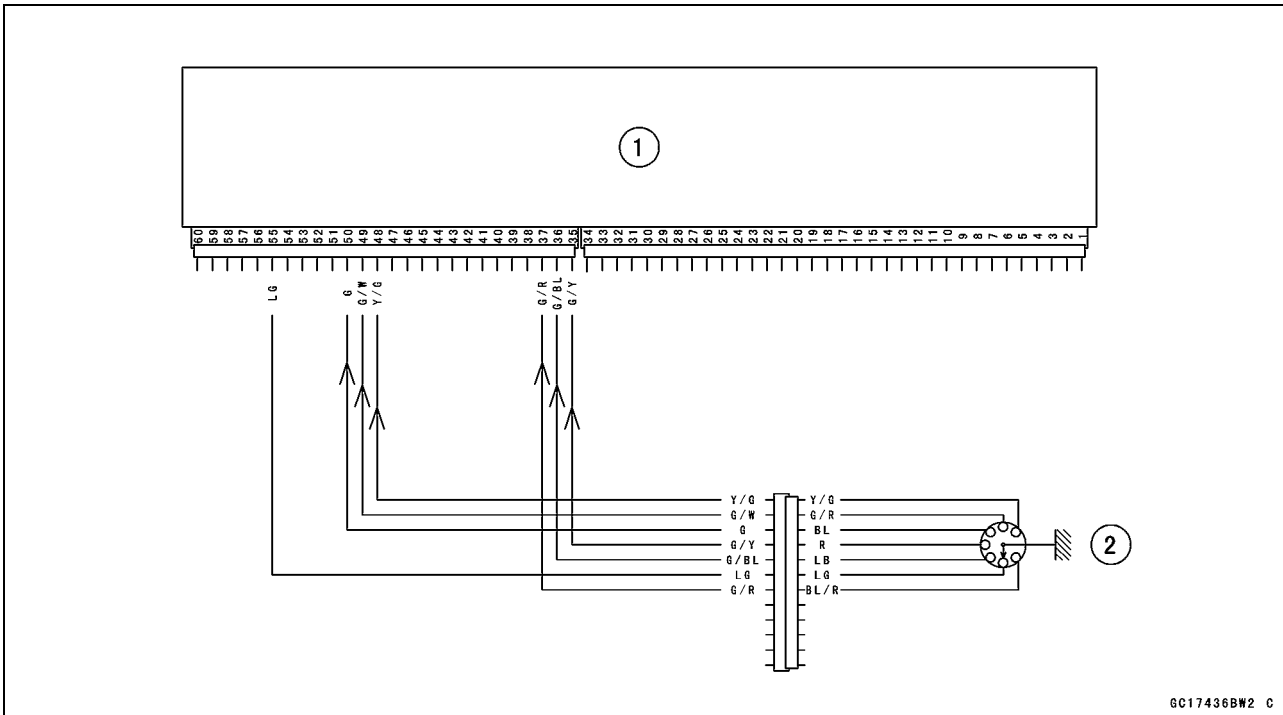

GC17436BW2 C

→: Signal
ECU [1]

Gear Position Switch [2]

Vehicle-down Sensor (Service Code 31)

This sensor has a weight [A] with two magnets inside, and sends a signal to the ECU. But when the motorcycle banks 60 ~ 70° or more to either side (in fact falls down), the weight turns and shuts off the signal. The ECU senses this change, and stops the fuel pump, the fuel injectors, and the ignition system.

Hall IC [B]

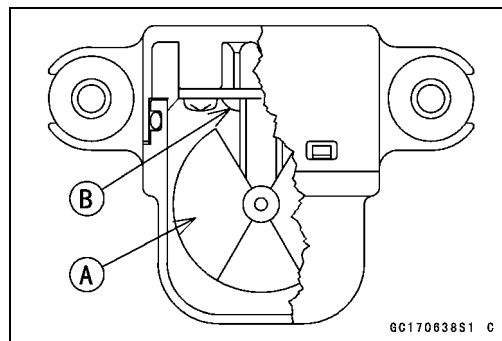

When the motorcycle is down, the ignition switch is left ON. If the starter button is pushed, the electric starter turns but the engine doesn't start. To start the engine again, raise the motorcycle, turn the ignition switch OFF, and then ON. When the ignition switch is turned ON, current flows through the latch-up circuit and the transistor in the circuit is turned ON to unlock the latch-up circuit.

- Vehicle-down Sensor [A]
- Ground Terminal BK/Y [B]
- Output Terminal Y/G [C]
- Power Source Terminal BR [D]

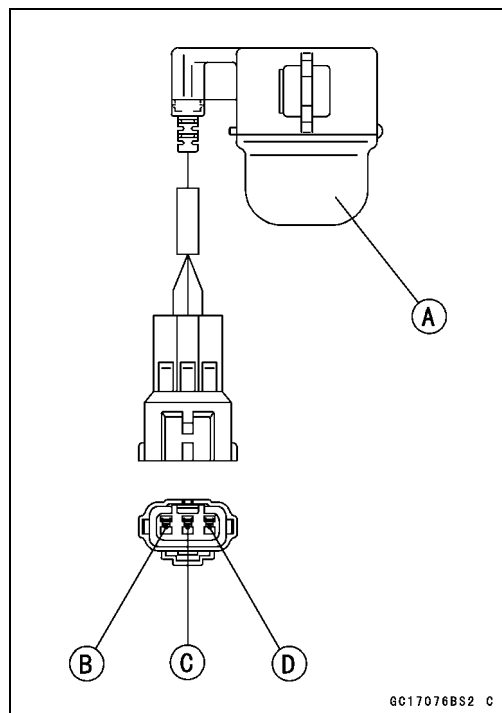

Removal

CAUTION

Never drop the down-sensor, especially on a hard surface. Such a shock to the sensor can damage it.

- Pull the battery tray (see Electrical System chapter).
- Remove:
 - Screw [A]
 - Cover [B]
- Turn Signal Relay [A]
- Screws [B]
- Vehicle-down Sensor [C]
- Push locks on center, and disconnect the connector [D].

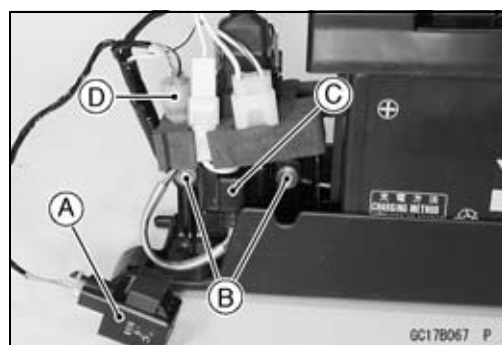
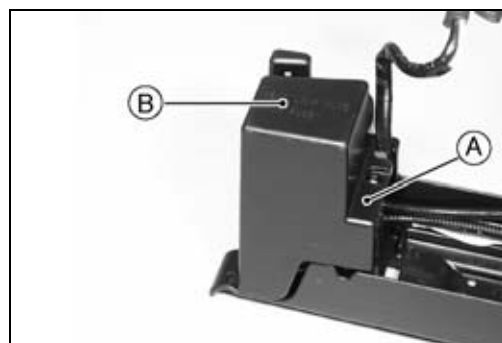

3-104 FUEL SYSTEM (DFI)

Vehicle-down Sensor (Service Code 31)

Installation

★The UP mark [A] of the sensor should face upward.

⚠ WARNING

Incorrect installation of the vehicle-down sensor could cause sudden loss of engine power. The rider could lose balance during certain riding situations, like leaning over in a turn, with the potential for an accident resulting in injury or death. Ensure that the down sensor is held in place by the sensor brackets.

- Again, make sure the vehicle-down sensor assy is in place.
- Tighten the screws securely [A].
- Install battery tray (see Electrical System chapter).

Inspection

NOTE

○Be sure the battery is fully charged.

- Remove:
 - Battery Tray (see Electrical System chapter)
 - Cover (see Removal in this section)
- Connect:
 - Battery (-) Terminal [A]
 - Connectors [B]

CAUTION

Do not short the starter motor cable terminal.

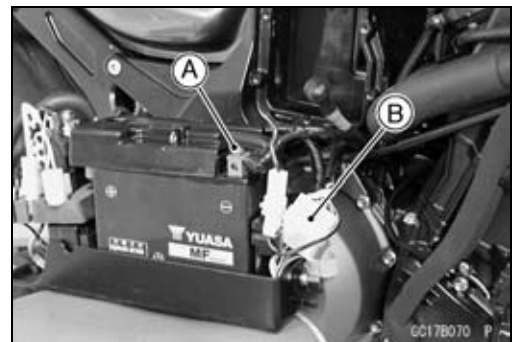
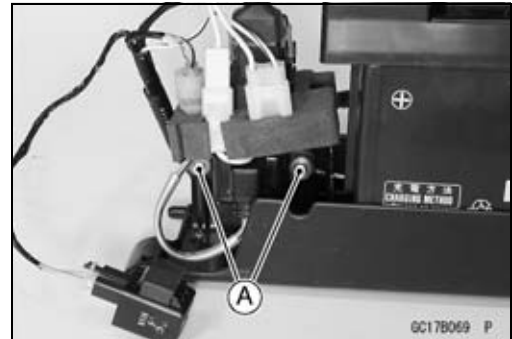
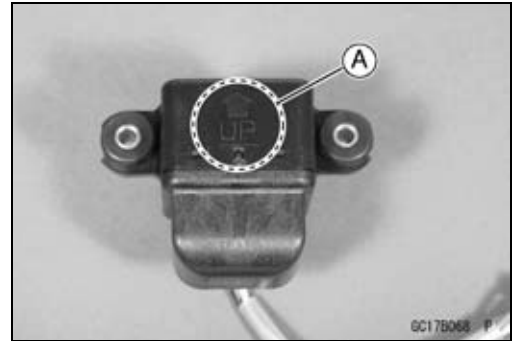

Vehicle-down Sensor (Service Code 31)

- Connect a digital volt meter [C] to the connector [B] (natural, 3P) of the vehicle-down sensor [A], with the needle adapter set [D].
- Turn the ignition switch ON, and measure the power source voltage with the connector joined.

Vehicle-down Sensor Power Source Voltage

Connections to Sensor

Meter (+) → W/Y lead [E]

Meter (-) → BK/Y lead [F]

Power Source Voltage at Sensor

Standard: Battery Voltage (12.5 V or more)

- Turn the ignition switch OFF.
- ★ If there is no battery voltage, check the following:
 Battery (see Electrical System chapter)
 ECU Main Fuse 15 A
 Wiring for Vehicle-down Sensor Power Source (see next diagram)
- ★ If the power source is normal, check the output voltage.

- Connect a digital volt meter [A] to the connector (natural, 3P), with needle adapter set [B].

Special Tool - Needle Adapter Set: 57001-1457

- Turn the ignition switch ON, and measure the output voltage with the connector joined.
- Remove the sensor.
- Tilt the sensor 60 ~ 70° or more [C] right or left, then hold the sensor almost vertical [D] with the arrow mark pointed up, and measure the output voltage.

Vehicle-down Sensor Output Voltage

Connections to Sensor

Meter (+) → Y/G lead [E]

Meter (-) → BK/Y lead [F]

Output Voltage at Sensor

Standard: with sensor tilted 60 ~ 70° or more right or left: 3.7 ~ 4.4 V
 with sensor arrow mark pointed up: 0.4 ~ 1.4 V

NOTE

○ If you need to test again, turn the ignition switch OFF, and then ON.

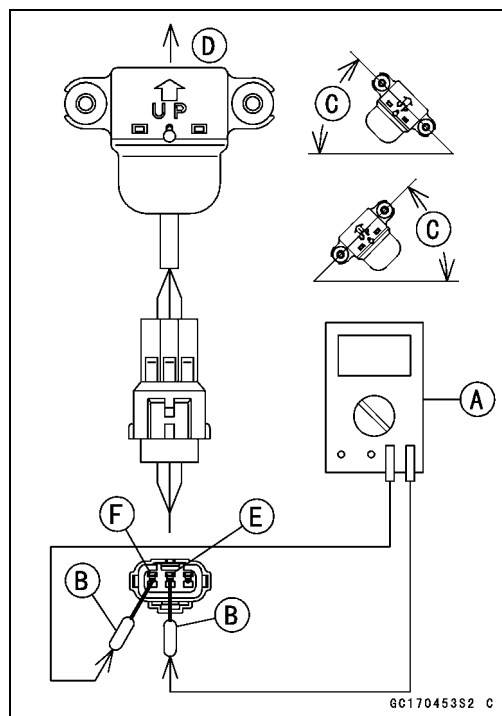
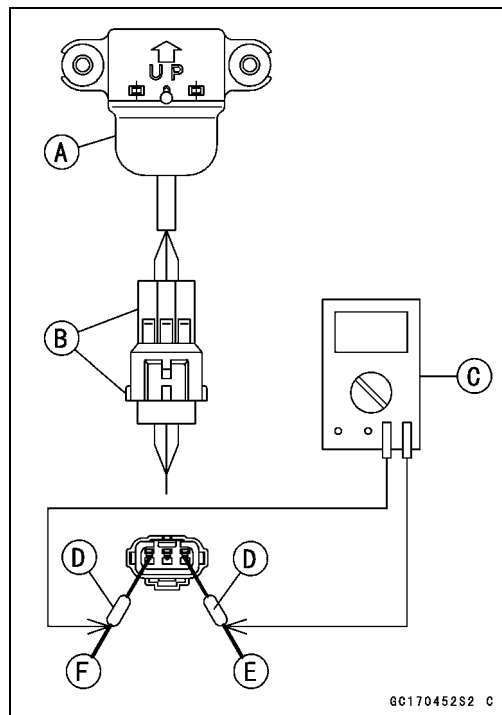

3-106 FUEL SYSTEM (DFI)

Vehicle-down Sensor (Service Code 31)

- Turn the ignition switch OFF.
- Remove the needle adapter set, and apply silicone sealant to the seals of the connector for waterproofing.

Silicone Sealant (Kawasaki Bond: 56019-120)

- Seals of Vehicle-down Sensor Connector

- ★ If the output voltage is normal, the wiring is suspect. Check the wiring.
- ★ If the wiring is good, check the ECU for its ground and power supply (see this chapter). If the ground and power supply are good, replace the ECU.
- ★ If the output voltage is out of the specified, replace the vehicle-down sensor.

ZX1200-B1/B2

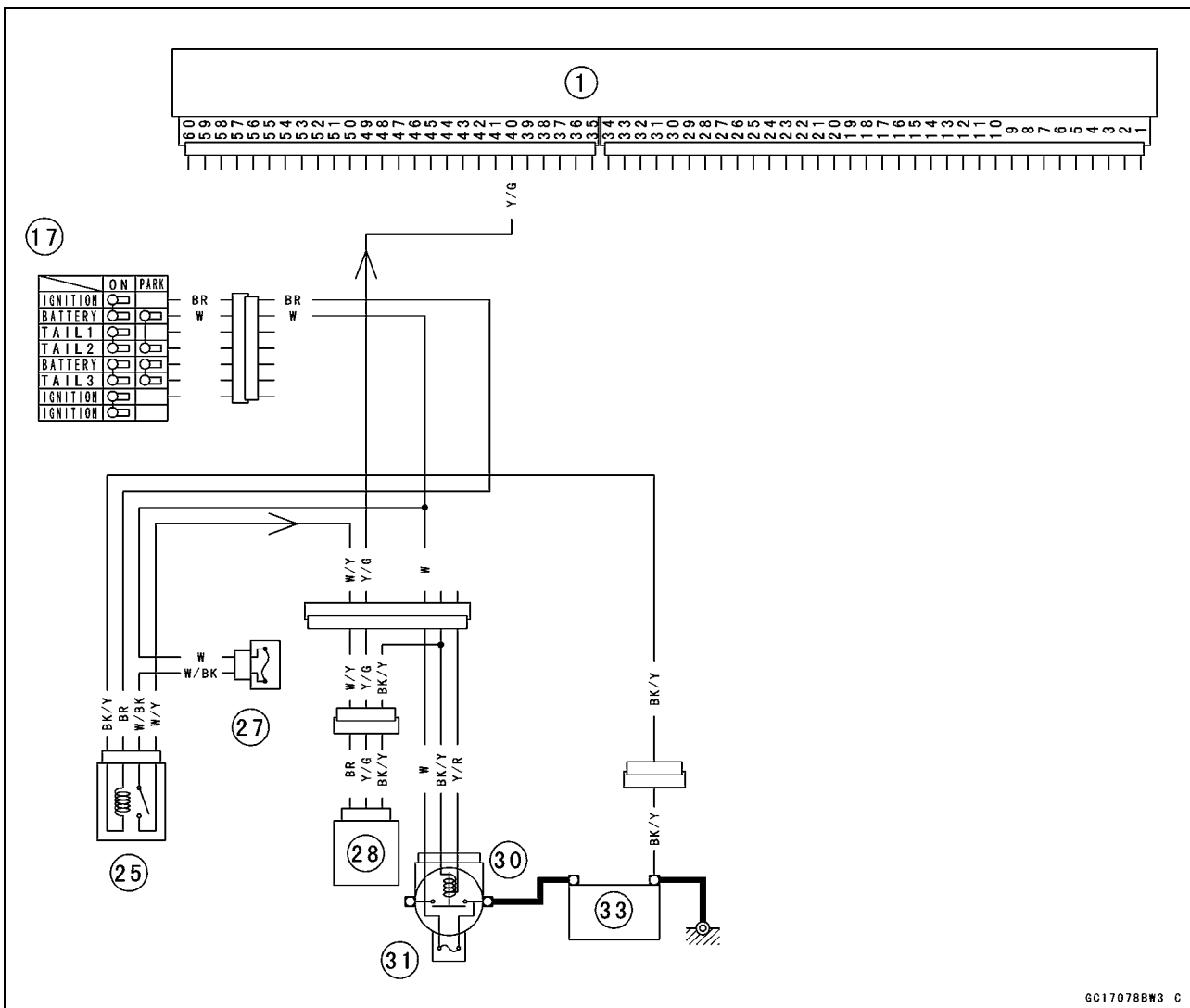

→: Signal

ECU [1]

Ignition Switch [17]

ECU Main Relay [25]

ECU Main Fuse 15 A [27]

Vehicle-down Sensor [28]

Starter Relay [30]

Main Fuse 30 A [31]

Battery [33]

GC17078BW3 C

Vehicle-down Sensor (Service Code 31)

ZX1200-B3

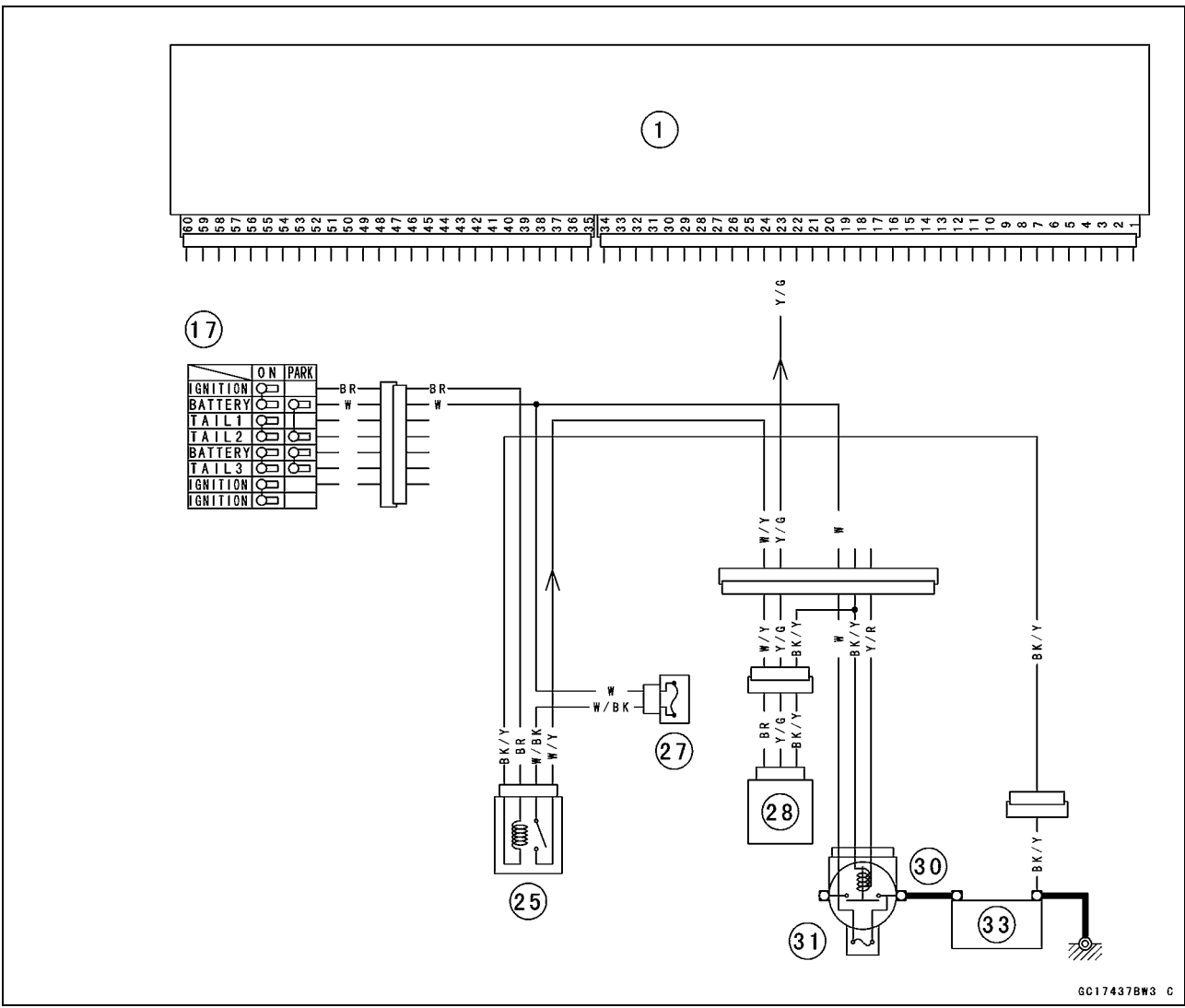

GC17437BW3 C

→: Signal

ECU [1]

Ignition Switch [17]

ECU Main Relay [25]

ECU Main Fuse 15 A [27]

Vehicle-down Sensor [28]

Starter Relay [30]

Main Fuse 30 A [31]

Battery [33]

3-108 FUEL SYSTEM (DFI)

Subthrottle Sensor (Service Code 32) (ZX1200-B3)

Subthrottle Sensor Removal/Adjustment

CAUTION

Do not remove or adjust the subthrottle sensor [A] since it has been adjusted and set with precision at the factory.

Never drop the sensor, especially on a hard surface. Such a shock to the sensor can damage it.

Subthrottle Sensor Connector (black) [B]

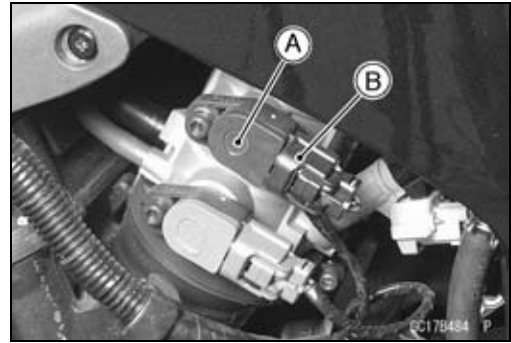

Input Voltage Inspection

NOTE

○Be sure the battery is fully charged.

- Turn the ignition switch OFF.
- Disconnect the subthrottle sensor connector (black) [A] and connect the harness adapter [B] between these connectors.
- Connect a digital meter to the harness adapter lead.

Special Tool - Throttle Sensor Harness Adapter: 57001-1538

- Measure the sensor input voltage with the engine stopped and with the connector joined.
- Turn the ignition switch ON.

Subthrottle Sensor Input Voltage Connections to Adapter

Meter (+) → BK (sensor BL/W) lead

Meter (-) → W (sensor BR/BK) lead

Standard : 4.75 ~ 5.25 V DC

- Turn the ignition switch OFF.
- ★ If the input voltage is normal, check the sensor output voltage.
- ★ If the input voltage is less than the standard, remove the ECU and check the wiring between these connectors.
- Disconnect the ECU and sensor connectors.

Wiring Connection

ECU Connector [A] ↔

Subthrottle Sensor Connector [B]

BL/W lead (ECU terminal 10)

BR/BK lead (ECU terminal 28)

- ★ If the wiring is good, check the ECU for its ground and power supply (see ECU section).

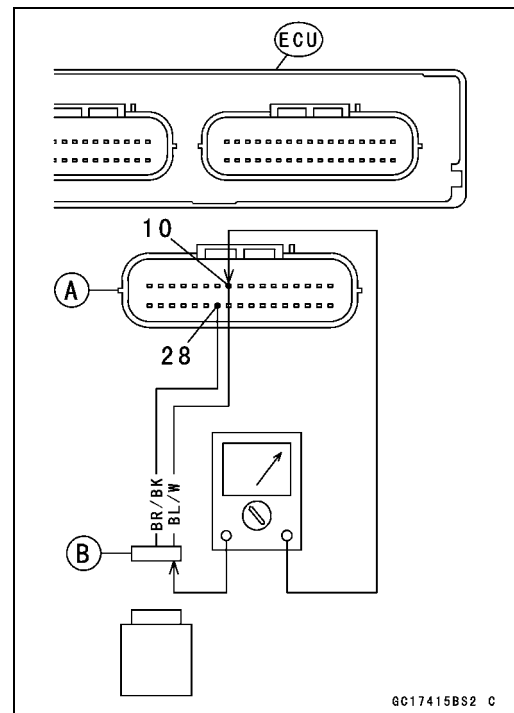

Subthrottle Sensor (Service Code 32) (ZX1200-B3)

Output Voltage Inspection

- Measure the output voltage at the subthrottle sensor in the same way as input voltage inspection. Note the following.
- Disconnect the subthrottle sensor connector (black) [A] and connect the harness adapter [B] between these connectors.

Special Tool - Throttle Sensor Harness Adapter: 57001-1538



- Measure the output voltage of the sensor with the engine running, and with the connector joined.
- Turn the ignition switch ON.
- Measure the output voltage when the subthrottle valve is fully opened or completely closed by hand.

Main Throttle Sensor Output Voltage

Connections to Adapter

Meter (+) → R (sensor BR) lead

Meter (-) → W (sensor BR/BK) lead

Standard:

0.48 ~ 0.52 V DC (at idle throttle opening)

3.6 ~ 4.0 V DC (at full throttle opening)

- ★ If the output voltage is out of the standard, inspect the subthrottle sensor resistance.
- ★ If the output voltage is normal, check the wiring for continuity.

Wiring Connection

ECU Connector [A] ↔

Subthrottle Sensor Connector [B]

BR lead (ECU terminal 24)

BR/BK lead (ECU terminal 28)

- ★ If the wiring is good, check the ECU for its ground and power supply (see ECU section).

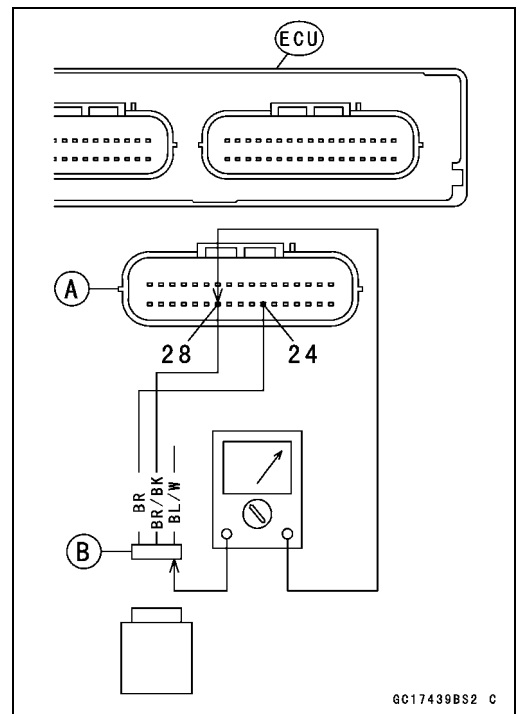

3-110 FUEL SYSTEM (DFI)

Subthrottle Sensor (Service Code 32) (ZX1200-B3)

Resistance Inspection

- Turn the ignition switch OFF.
- Disconnect the subthrottle sensor connector.
- Connect a digital meter [A] to the subthrottle sensor connector [B].
- Measure the subthrottle sensor resistance.

Throttle Sensor Resistance

Connections: BL/W lead [C] ↔ BR/BK lead [D]

Standard: 4 ~ 6 kΩ

★ If the reading is out of the range, replace the throttle body assy.

★ If the reading is within the range, but the problem still exists, replace the ECU (see this chapter).

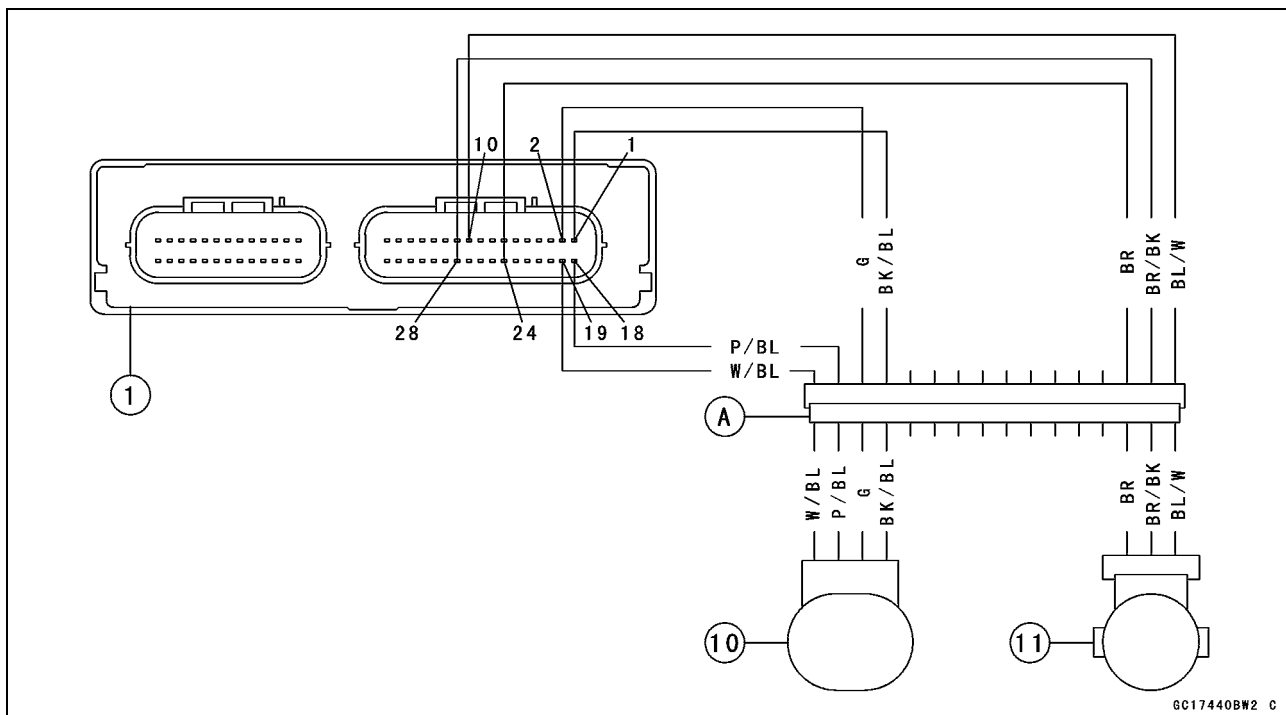
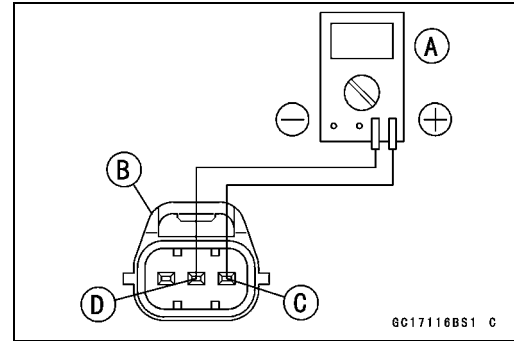

1. ECU
10. Subthrottle Valve Actuator

11. Subthrottle Sensor
A. Throttle Body Assy Connector

Immobilizer Amplifier (Service Code 35) (ZX1200-B3)

Antenna Resistance Inspection

- Remove:
 - Left Lower Inner Cover (see Frame chapter)
- Disconnect:
 - Antenna Lead Connector [A]
- Measure the resistance of the antenna coil in the ignition switch as follows.

**Antenna Resistance
Connections to Antenna**

Meter → Red Lead

Meter → Red Lead

Standard: About 0.6 ~ 0.9 Ω

- ★If the resistance is out of the standard range, replace the ignition switch.

Amplifier Input Voltage Inspection

NOTE

○Be sure the battery is fully charged.

- Turn the ignition switch OFF.
- Remove:
 - Upper Fairing (see Frame chapter)
- Connect a digital voltmeter to the connectors, using the needle adapter set.

Special Tool - Needle Adapter Set: 57001-1457

**Amplifier Input Voltage
Connections to Connectors**

Meter (+) →

BR/W Lead in Meter Lead Connector [A]

Meter (-) →

BK/Y Lead in Amplifier Lead Connector [B]

- Measure the input voltage DC with the connectors joined.
- Turn the ignition switch ON.

Input Voltage

Standard: Battery Voltage

- Turn the ignition switch OFF.
- ★If the reading is out of the range, check the wiring (see wiring diagram in next section).
- ★If the reading and antenna resistance are good, replace the amplifier.

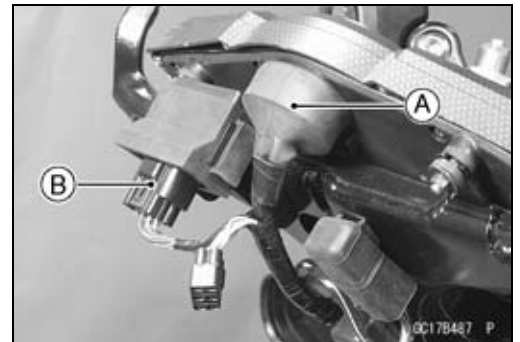
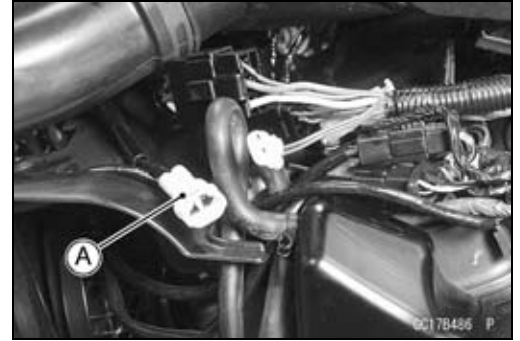

3-112 FUEL SYSTEM (DFI)

Blank Key Detection (Service Code 36) (ZX1200-B3)

This code appears in the following conditions.

- The transponder [A] in the master and/or user key is malfunction.
- When the spare key of unregistration is used.
- When the master key is registered in the registered ECU. Therefore, the service code 36 will disappear when the above issue is solved.

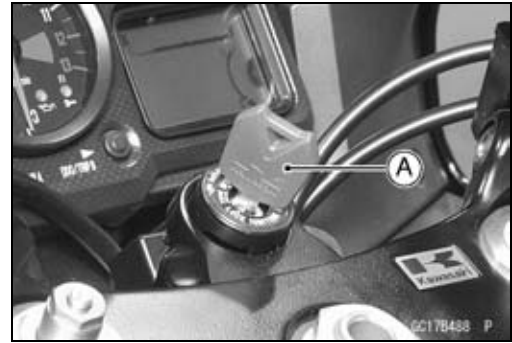

User Key Inspection

- Register the user key correctly (see Electrical System chapter).
- ★ If the service code 36 appears again, the transponder in the key is malfunction, replace it.

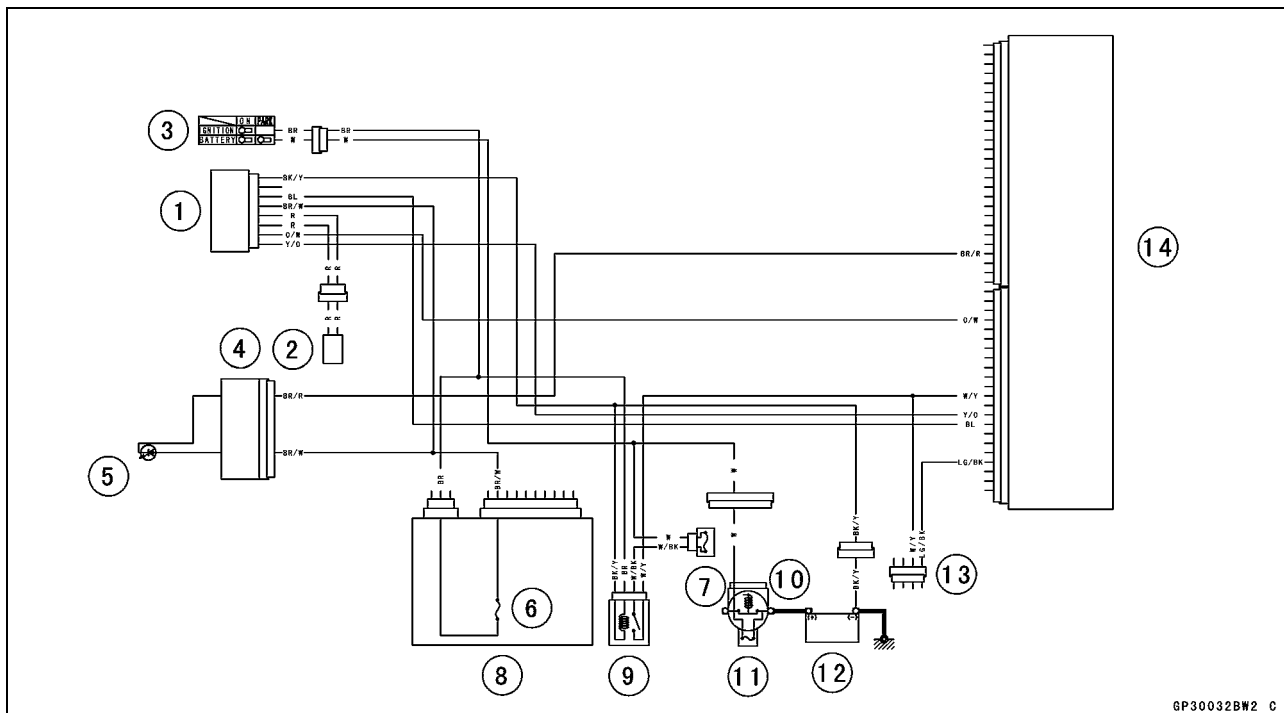

GP30032BW2 C

- | | |
|-----------------------------|--|
| 1. Immobilizer Amplifier | 9. ECU Main Relay |
| 2. Immobilizer Antenna | 10. Starter Relay |
| 3. Ignition Switch | 11. Main Fuse 30 A |
| 4. Meter Unit | 12. Battery |
| 5. FI Indicator Light (LED) | 13. Immobilizer/Kawasaki Diagnostic System Connector |
| 6. Ignition Fuse 10 A | 14. ECU |
| 7. ECU Fuse 15 A | |
| 8. Junction Box | |

Fuel Injectors (#1, #2, #3, #4: Service Code 41, 42, 43, 44)

- Fuel Injector #1: (Service Code 41)
- Fuel Injector #2: (Service Code 42)
- Fuel Injector #3: (Service Code 43)
- Fuel Injector #4: (Service Code 44)

CAUTION

Never drop the injector, especially on a hard surface. Such a shock to the injector can damage it.

NOTE

○Do not remove the injectors from the throttle body.

Power Source Voltage Inspection

NOTE

○Be sure the battery is fully charged.

- Turn the ignition switch OFF.
 - Remove the ECU (see this chapter). Do not disconnect the ECU connectors.
 - Connect a digital voltmeter [A] to the connector [B], with the needle adapter set [C].
- Measure the power source voltage with the engine stopped, and with the connectors joined.

Special Tool - Needle Adapter Set: 57001-1457

- Turn the ignition switch ON.

Injector Power Source Voltage at ECU Connections to ECU

ZX1200-B1/B2:

Meter (+) → W/R lead (terminal 42)

Meter (-) → Battery (-) Terminal

ZX1200-B3:

Meter (+) → W/R lead (terminal 33)

Meter (-) → Battery (-) Terminal

Power Source Voltage at ECU

Standard: Battery Voltage (12.5 V or more)

★If the power source voltage is less than the standard, check the ECU for its ground, and power supply (see this chapter). If the ground and power supply are good, replace the ECU.

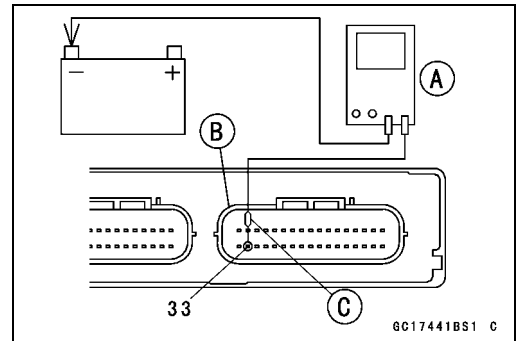
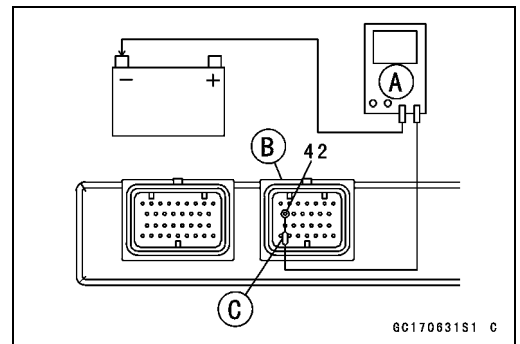

3-114 FUEL SYSTEM (DFI)

Fuel Injectors (#1, #2, #3, #4: Service Code 41, 42, 43, 44)

- ★ If the reading is normal, check the power source voltage at the injector connector [B], with a digital volt meter [A].
- Measure the power source voltage with the engine stopped, and the connector joined, with a digital meter and needle adapter set [C].
- Turn the ignition switch ON.
 - Injector #1 BL/R Lead [E]
 - Injector #2 BL/G Lead [F]
 - Injector #3 BL/BK Lead [G]
 - Injector #4 BL/Y Lead [H]
 - Injector Power Supply W/R Lead [I]

Injector Power Source Voltage at Injector Connections to Injector #1, #2, #3, #4

Meter (+) → W/R lead [I]

Meter (-) → Battery (-) Terminal [D]

Power Source Voltage at Injector Connector

Standard: Battery Voltage (12.5 V or more)

- Turn the ignition switch OFF.
- ★ If the reading is out of the standard, check the wiring (see wiring diagram in this section).
- ★ If the reading is good, and the power source voltage is normal, check the output voltage.

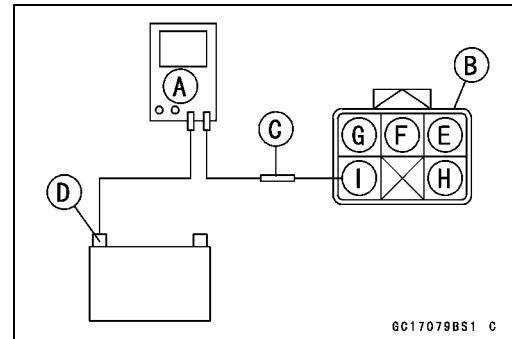
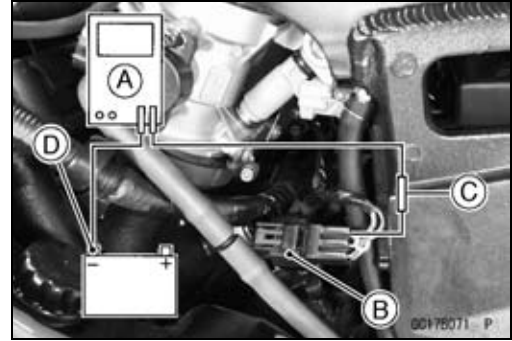

Fuel Injectors (#1, #2, #3, #4: Service Code 41, 42, 43, 44)

Output Voltage Inspection

- Measure the output voltage at the ECU connector in the same way as power source voltage inspection. Note the following.

Injector Output Voltage at ECU

ZX1200-B1/B2:

Connections for Injector #1

Meter (+) → BL/R lead (terminal 4)

Meter (-) → Battery (-) Terminal

Connections for Injector #2

Meter (+) → BL/G lead (terminal 5)

Meter (-) → Battery (-) Terminal

Connections for Injector #3

Meter (+) → BL/BK lead (terminal 6)

Meter (-) → Battery (-) Terminal

Connections for Injector #4

Meter (+) → BL/Y lead (terminal 7)

Meter (-) → Battery (-) Terminal

ZX1200-B3:

Connections for Injector #1

Meter (+) → BL/R lead (terminal 44)

Meter (-) → Battery (-) Terminal

Connections for Injector #2

Meter (+) → BL/G lead (terminal 43)

Meter (-) → Battery (-) Terminal

Connections for Injector #3

Meter (+) → BL/BK lead (terminal 42)

Meter (-) → Battery (-) Terminal

Connections for Injector #4

Meter (+) → BL/Y lead (terminal 41)

Meter (-) → Battery (-) Terminal

Output Voltage at ECU

Standard: Battery Voltage (12.5 V or more)

- ★If the output voltage is normal, check the ECU for its ground, and power supply (see this chapter). If the ground and power supply are good, replace the ECU.

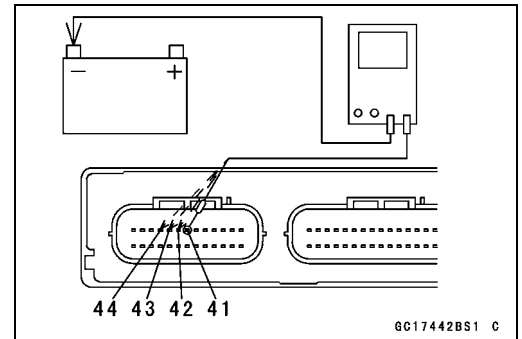
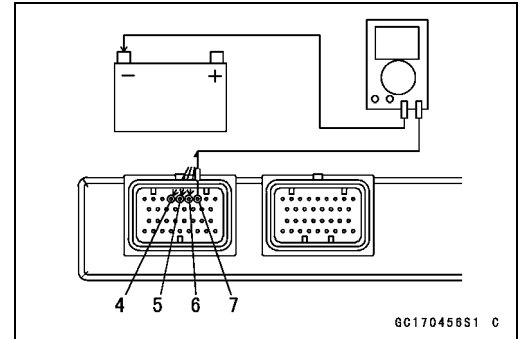

3-116 FUEL SYSTEM (DFI)

Fuel Injectors (#1, #2, #3, #4: Service Code 41, 42, 43, 44)

★If the output voltage is out of the standard, remove the left lower inner cover, and check the output voltage at the injector connector [B] using a digital meter [A] and needle adapter set [C] (when the lead is open, the output voltage is 0 V).

Injector Output Voltage at Injector

Connections to Injector #1

Meter (+) → BL/R lead [E]

Meter (-) → Battery (-) Terminal [D]

Connections to Injector #2

Meter (+) → BL/G lead [F]

Meter (-) → Battery (-) Terminal [D]

Connections to Injector #3

Meter (+) → BL/BK lead [G]

Meter (-) → Battery (-) Terminal [D]

Connections to Injector #4

Meter (+) → BL/Y lead [H]

Meter (-) → Battery (-) Terminal [D]

Output Voltage at Injector Connector

Standard: Battery Voltage (12.5 V or more)

★If the output voltage is normal, check the wiring for continuity (see next diagram). If the wiring is good, perform “Audible Inspection” for confirmation.

★If the output voltage is out of the standard, perform “Audible Inspection” for confirmation.

Audible Inspection

- Start the engine.
- Apply the tip of a screwdriver [A] to the injector [C]. Put the grip end onto your ear, and listen whether the injector is clicking or not.
- A sound scope [B] can also be used.
- Do the same for the other injector.
- ★If all the injectors click at a regular intervals, the injectors are good.
- The click interval becomes shorter as the engine speed rises.
- ★If either injector doesn't click, perform the “Injector Signal Test” for injector operation.

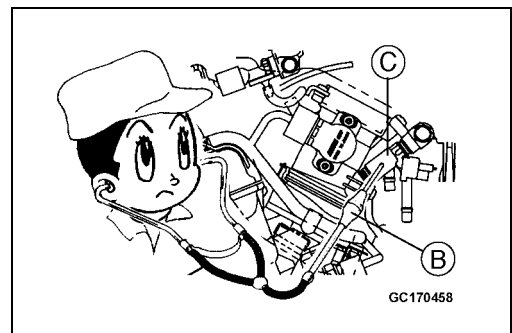
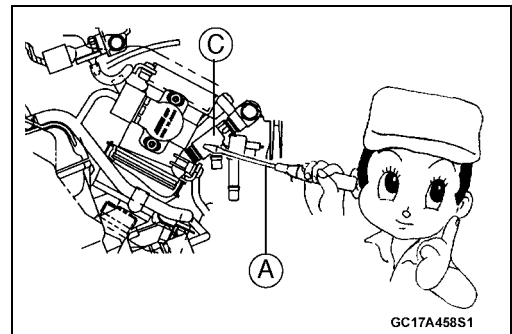
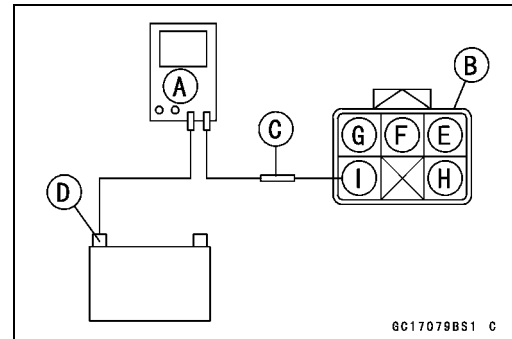
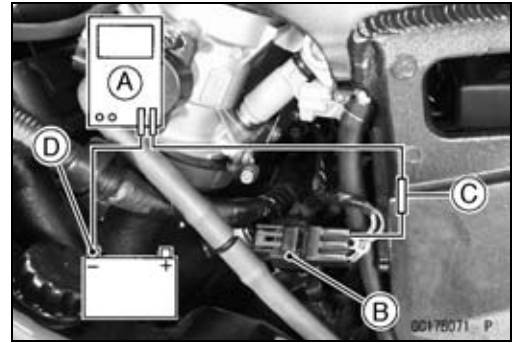

Fuel Injectors (#1, #2, #3, #4: Service Code 41, 42, 43, 44)

Injector Signal Test

- Prepare two test light sets with male terminals as shown.
 - Rating of Bulb [A]: 12 V × 3 ~ 3.4 W
 - Terminal Width [B]: 1.8 mm (0.07 in.)
 - Terminal Thickness [C]: 0.8 mm (0.03 in.)

CAUTION

Do not use larger terminals than specified above. A larger terminal could damage the injector main harness connector (female), leading to harness repair or replacement.

Be sure to connect bulbs in series. The bulb works as a current limiter to protect the solenoid in the injector from excessive current.

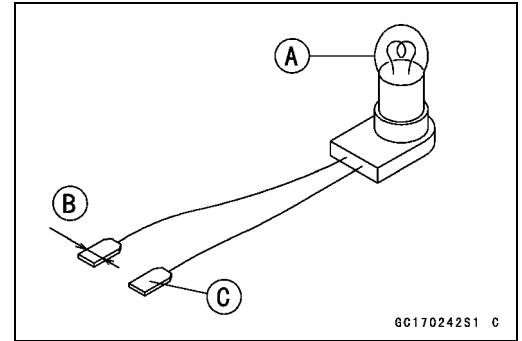

- Remove connectors for injector [A].
- Connect each test light set [B] to the injector sub harness connector [C].
- Turn the ignition switch ON.
- While cranking the engine with the starter motor, watch the test lights.
- ★ If the test lights flicker at regular intervals, the injector circuit in the ECU, and the wiring are good. Perform the "Injector Resistance Inspection".

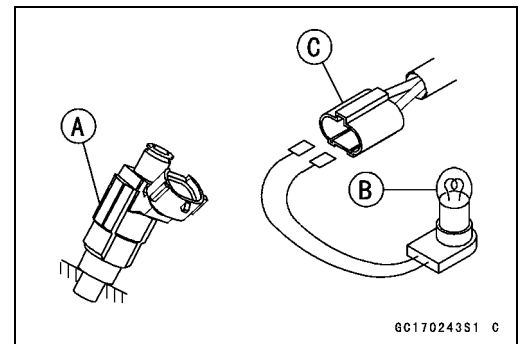

○ Injector signals can be also confirmed by connecting the hand tester (× 10 V AC) instead of the test light set to the injector main harness (female) connector. Crank the engine with the starter motor, and check to see if the hand oscillates at regular intervals.

Special Tool - Hand Tester: 57001-1394

- ★ If the test light doesn't flicker (or the test hand doesn't oscillates), check the wiring and connectors again. If the wiring is good, replace the ECU.

3-118 FUEL SYSTEM (DFI)

Fuel Injectors (#1, #2, #3, #4: Service Code 41, 42, 43, 44)

Injector Resistance Inspection

- Remove the throttle body assy (see Throttle Body Assy Removal).
- Disconnect the connector [B] from the injector (see Throttle Body Disassembly/Assembly).
- Measure the injector resistance with the hand tester [A].

Special Tool - Hand Tester: 57001-1394

Injector Resistance

Connections to Injector

	Meter (+)	Meter (-)
#1:	W/R	BL/R Terminal
#2:	W/R	BL/G Terminal
#3:	W/R	BL/BK Terminal
#4:	W/R	BL/Y Terminal

Standard: about 12.5 Ω @20°C (68°F)

- ★ If the reading is out of the range, perform the "Injector Unit Test".
- ★ If the reading is normal, perform the "Injector Unit Test" for confirmation.

Injector Unit Test

- Use two leads [A] and the same test light set [B] as in "Injector Signal Test".
Rating of Bulb [C]: 12 V \times (3 ~ 3.4) W
12 V Battery [D]

CAUTION

Be sure to connect the bulb in series. The bulb works as a current limiter to protect the solenoid in the injector from excessive current.

- Connect the test light set to the injector [E] as shown.
- Open and connect [F] the end of the lead to the battery (-) terminal repeatedly. The injector should click.
- ★ If the injector does not click, replace the throttle body assy.
- ★ If the injector clicks, check the wiring again. If the wiring is good, replace the ECU.

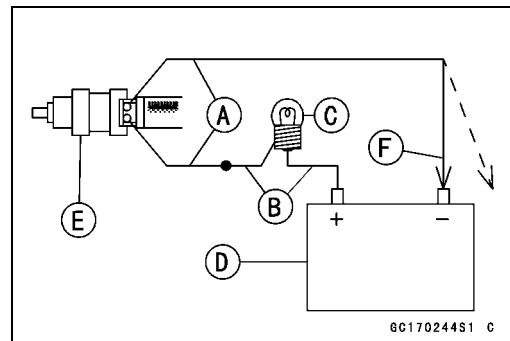
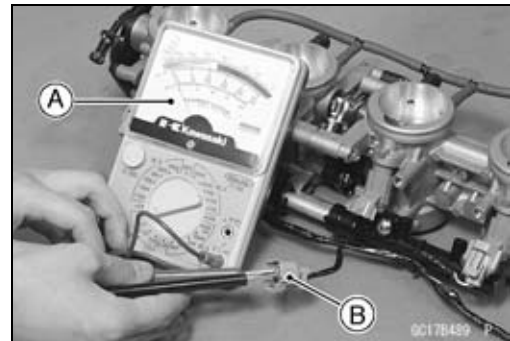
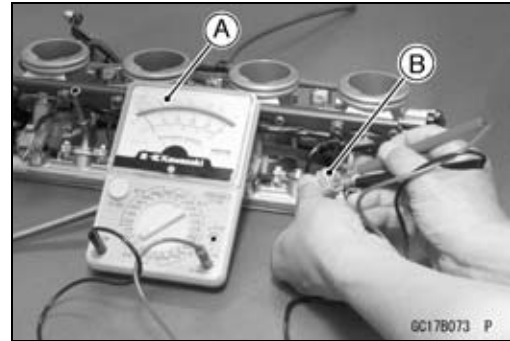

Fuel Injectors (#1, #2, #3, #4: Service Code 41, 42, 43, 44)

Injector Fuel Line Inspection

- Remove the throttle body assy (see this chapter).
- Check the injector [A] fuel line for leakage as follows:
 - Connect a commercially available vacuum/pressure pump [B] to the nipple [C] of the delivery pipe [D] with the fuel hose [E] (both ends connected with the clamps [H]) as shown.
 - Apply soap and water solution to the areas [F] shown.
 - Watching the pressure gauge, squeeze the pump lever [G], and build up the pressure until the pressure reaches the maximum pressure.

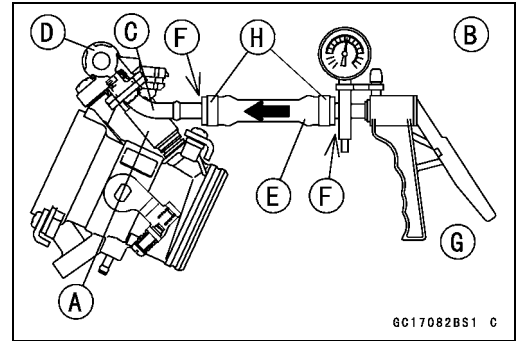

Fuel Line Maximum Pressure

Standard: 300 kPa (3.06 kgf/cm², 43 psi)

CAUTION

During pressure testing, do not exceed the maximum pressure for which the system is designed.

- Watch the gauge for at least 6 seconds.
- ★ If the pressure holds steady, the system is good.
- ★ If the pressure drops at once, or if bubbles are found in the area, the line is leaking. Perform the following as necessary.
 - Retighten the fuel hose clamps.

Torque - Fuel Hose Clamp Screws: 1.5 N·m (0.15 kgf·m, 13 in·lb)
- Repeat the leak test, and check the fuel line for no leakage.
- ★ If again the pressure drops at once, or if bubbles are found the area, replace the injectors, delivery pipe or related parts.
- Install the throttle body assy (see this chapter).
- Run the hoses correctly (see Cable, Wire, and Hose Routing section in General Information chapter).

Torque - Fuel Hose Clamp Screws: 1.5 N·m (0.15 kgf·m, 13 in·lb)

3-120 FUEL SYSTEM (DFI)

Fuel Injectors (#1, #2, #3, #4: Service Code 41, 42, 43, 44)

ZX1200-B1/B2

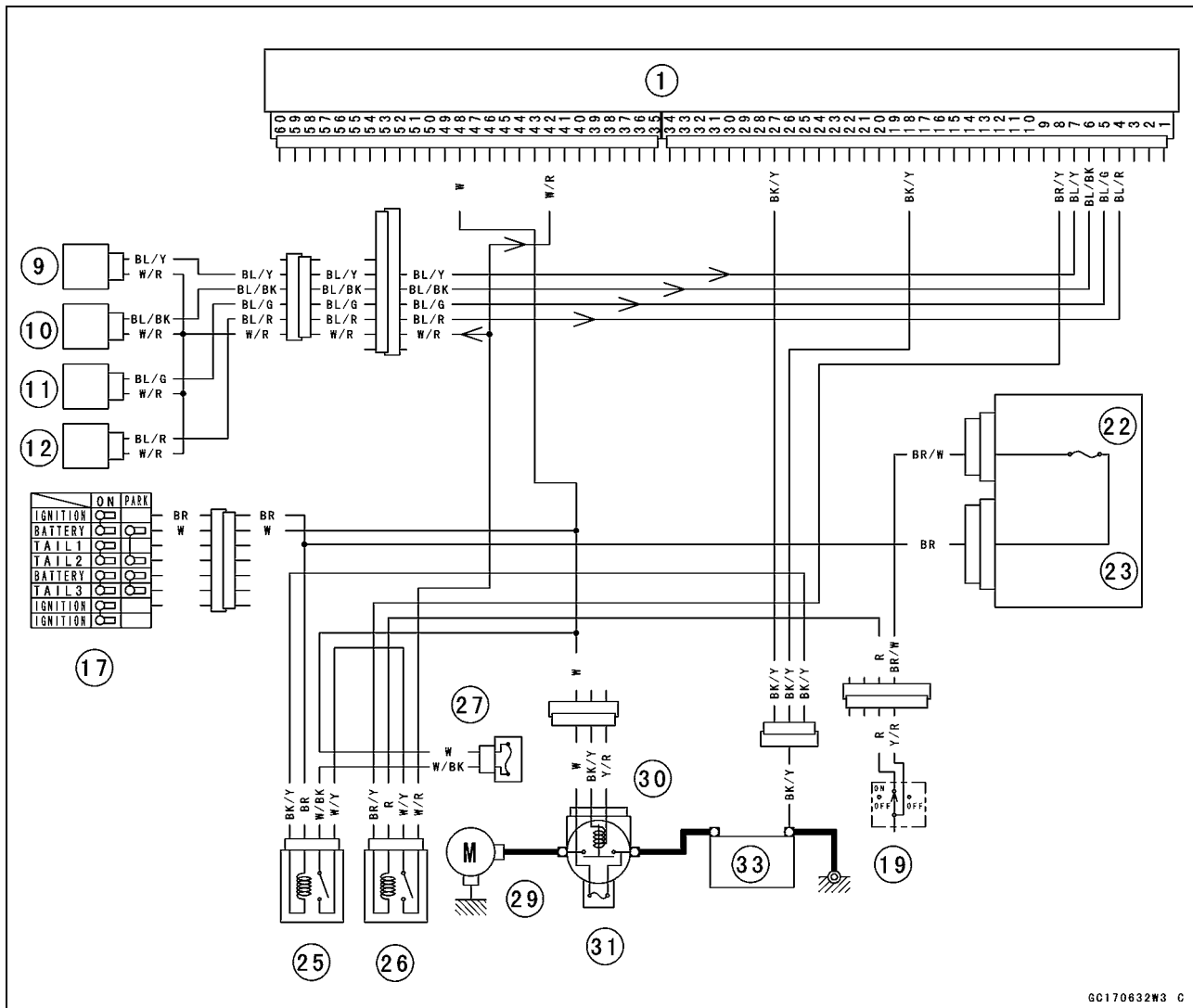

GC170632W3 C

→: Signal

ECU [1]

Fuel Injector #4 [9]

Fuel Injector #3 [10]

Fuel Injector #2 [11]

Fuel Injector #1 [12]

Ignition Switch [17]

Engine Stop Switch [19]

Junction Box [22]

Ignition Fuse 10 A [23]

ECU Main Relay [25]

Fuel Pump Relay [26]

ECU Fuse 15 A [27]

Starter Motor [29]

Starter Relay [30]

Main Fuse 30 A [31]

Battery [33]

Fuel Injectors (#1, #2, #3, #4: Service Code 41, 42, 43, 44)

ZX1200-B3

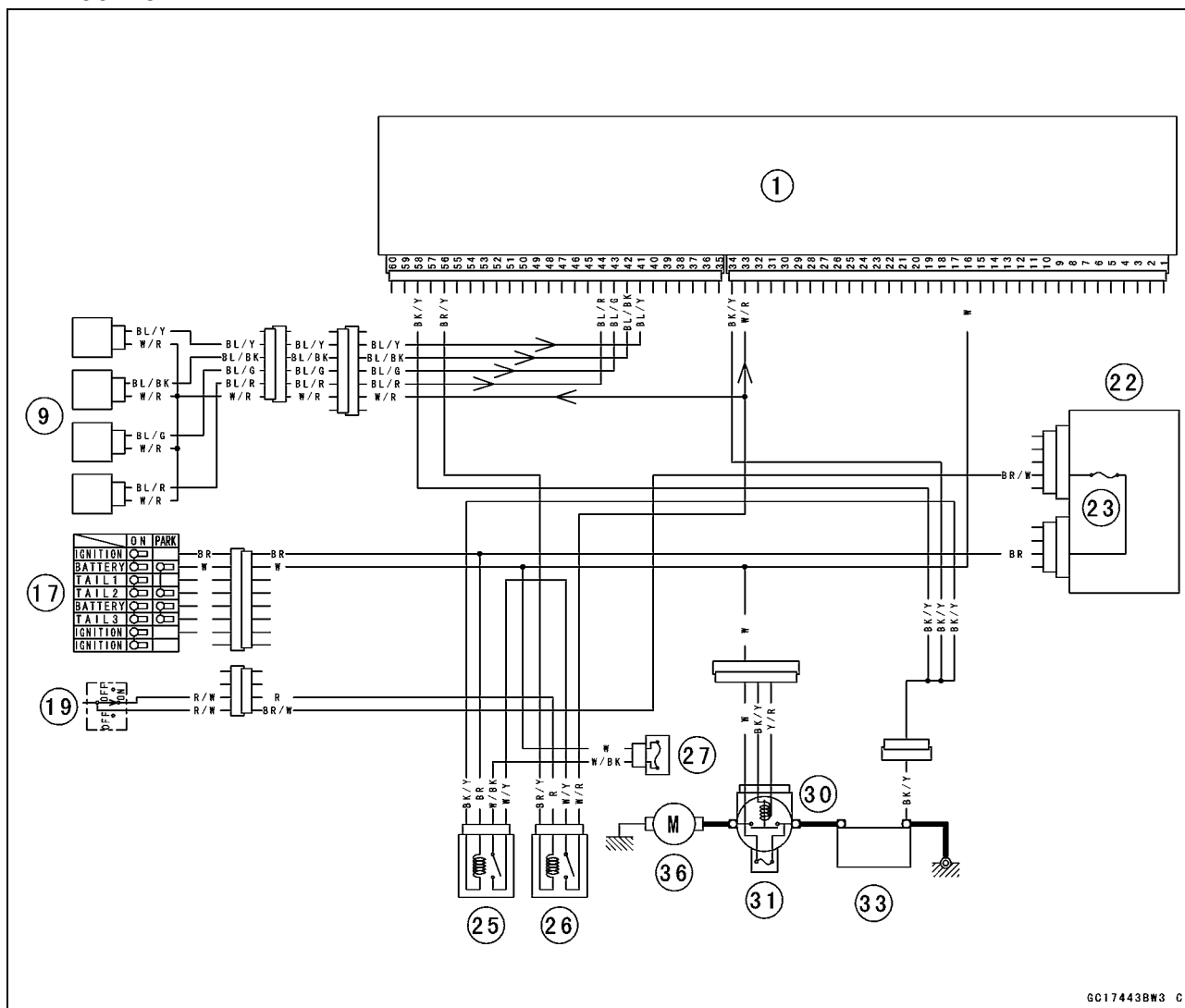

GC17443BW3 C

→: Signal

ECU [1]

Fuel Injector #1, #2, #3, #4 [9]

Ignition Switch [17]

Engine Stop Switch [19]

Junction Box [22]

Ignition Fuse 10 A [23]

ECU Main Relay [25]

Fuel Pump Relay [26]

ECU Fuse 15 A [27]

Starter Relay [30]

Main Fuse 30 A [31]

Battery [33]

Starter Motor [36]

3-122 FUEL SYSTEM (DFI)

Fuel Pump Relay (Service Code 45, 46)

Service code 45 is short or open to the fuel pump relay system.

Service code 46 is stuck ON to the fuel pump relay system.

Fuel Pump Relay Removal

CAUTION

Never drop the relay, especially on a hard surface. Such a shock to the relay can damage it.

- Remove:
 - Fuel Tank Cover (see Fuel Tank Removal)
 - Bracket Bolt [A]
- Disconnect the connector and remove the fuel pump relay [B].

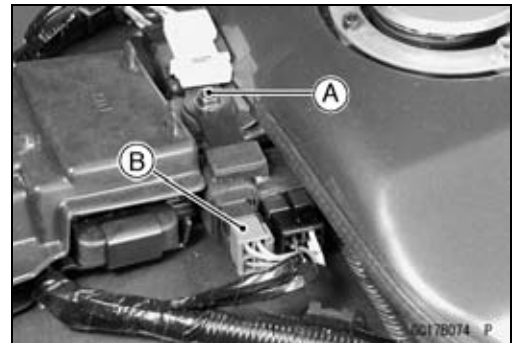

Operating Voltage Inspection

NOTE

○ Be sure the battery is fully charged.

- Turn the ignition switch OFF.
- Remove the ECU (see this chapter). Do not disconnect the ECU connectors.
- Connect the hand tester (× 25 V DC) to the connectors [A], with the needle adapter set [B].

Special Tools - Hand Tester: 57001-1394

Needle Adapter Set: 57001-1457

- Measure the operating voltage with the engine stopped, and with the connector joined.
- Turn the ignition switch ON.
- The tester hand does not move for 3 seconds, and then indicate the battery voltage.

Fuel Pump Relay Operating Voltage at ECU Connection to ECU

ZX1200-B1/B2:

Tester (+) → BR/Y lead (terminal 8)

Tester (-) → Battery Ground Terminal

ZX1200-B3:

Tester (+) → BR/Y lead (terminal 56)

Tester (-) → Battery Ground Terminal

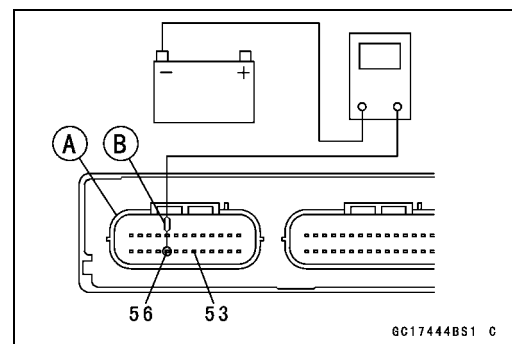
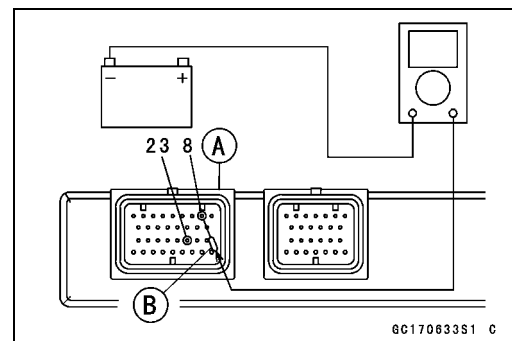

Operating Voltage at ECU

Standard: 0 V or 1 V for 3 seconds, and then battery voltage (12.5 V) or more

Fuel Pump Relay (Service Code 45, 46)

- ★If the reading stays on 12.5 V or more, check the following.
 - [1] Vehicle-down Sensor (see this chapter)
 - [2] Emergency Engine Stop Voltage
(ZX1200-B1/B2: Terminal 23 ←→ Ground)
(ZX1200-B3: Terminal 53 ←→ Ground)
 - [3] ECU for its Ground, and Power Supply

★If the reading stays on 0 V, and never shows, battery voltage (12.5 V), check the ECU for its ground and power supply (see this chapter).

★If the ground and power supply are good, replace the ECU.

★If there is no battery voltage at all, check the relay operating voltage at the relay connector as follows.

- Remove the fuel tank cover. Do not disconnect the relay connector.
 - Hand Tester [A]
 - Fuel Pump Relay Connector [B]

**Fuel Pump Relay Operating Voltage at Relay Connector
Connection to Relay Connect**

Tester (+) → R lead [C]

Tester (-) → Battery (-) Terminal [D]

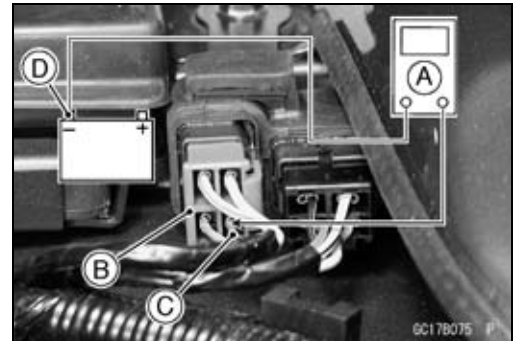

Operating Voltage at Pump Connector

Standard: Battery Voltage (12.5 V or more)

- ★If the voltage is in specification, check the relay (see Electrical System chapter) and wiring continuity.
- ★If the voltage is not specification, check the following.
 - [1] Ignition Fuse 10 A (see Electrical System chapter)
 - [2] ECU Fuse 15 A (see this chapter)
 - [3] Engine Stop Switch (see Electrical System chapter)
 - [4] ECU Main Relay (see this chapter)
 - [5] Wiring for Fuel Pump Relay Operating Voltage (see next diagram)

3-124 FUEL SYSTEM (DFI)

Fuel Pump Relay (Service Code 45, 46)

Power Source Voltage Inspection

NOTE

- Confirm that the operation voltage is normal before inspecting the power source voltage.
- Be sure the battery is fully charged.

- Connect the hand tester ($\times 25$ V DC) [A] to the connector [B], with the needle adapter set [C].

Special Tools - Hand Tester: 57001-1394

Needle Adapter Set: 57001-1457

- Measure the power source voltage with the engine stopped, and with the connector joined.
- Turn the ignition switch ON.
- The tester hand should indicate battery voltage for 3 seconds, and then 0 V.

Relay Power Source Voltage Connections to ECU

ZX1200-B1/B2:

Tester (+) → W/R lead (terminal 42)

Tester (-) → BK/Y lead (terminal 35)

ZX1200-B3:

Tester (+) → W/R lead (terminal 33)

Tester (-) → BK/Y lead (terminal 34)

Power Source Voltage at ECU

Standard: Battery Voltage (12.5 V or more), and the 0 V

- ★ If the power source voltage is less than the standard, check the ECU for its ground, and power supply (see this chapter).
- ★ If the ground and power supply are good, replace the ECU.
- ★ If the reading stays on battery voltage, and never shows 0 V, recheck the operating voltage or check the fuel pump relay power source voltage at the relay connector.

- Connect the hand tester [A] to the fuel pump relay connector [B].
- Measure the power source voltage with the engine stopped, and with the relay connector joined.
- Turn the ignition switch ON.

Fuel Pump Relay Power Source Voltage Connections to Relay Connector

Tester (+) → W/Y lead [C]

Tester (-) → Battery (-) Terminal [D]

Power Source Voltage at Relay Connector

Standard: Battery Voltage (12.5 V or more)

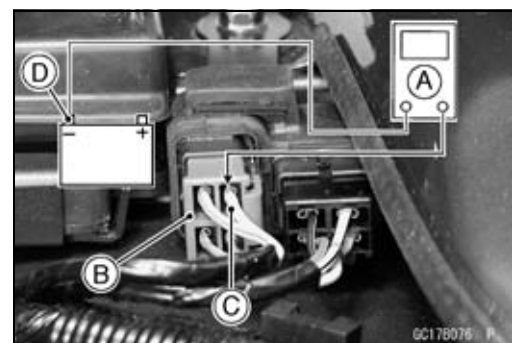
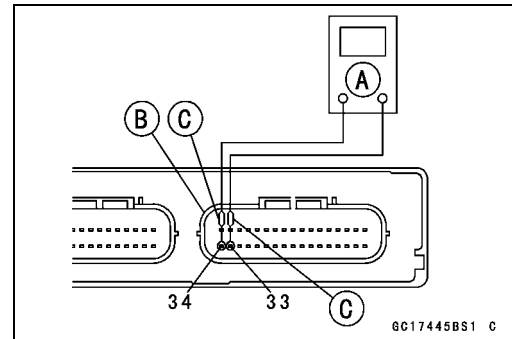
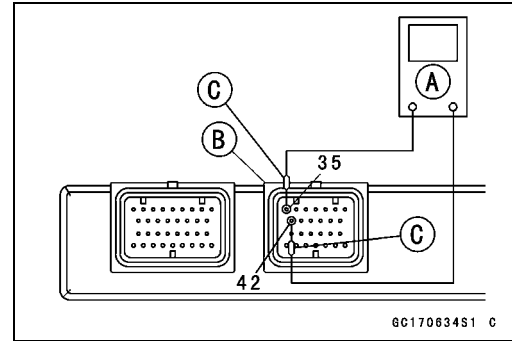

Fuel Pump Relay (Service Code 45, 46)

- ★ If the reading is good, the power source voltage is normal.
Check the fuel pump relay and wiring continuity.
- ★ If there is no battery voltage, check the following:
 - ECU Fuse 15 A (see this chapter)
 - ECU Main Relay (see this chapter)
 - Wiring for Fuel Pump Relay Power Source Voltage System

Relay Inspection

- Remove the fuel pump relay (see this section).
- Refer to the ECU Main Relay Inspection for fuel pump relay inspection.
- Fuel pump relay is identical part the ECU main relay.

ZX1200-B1/B2

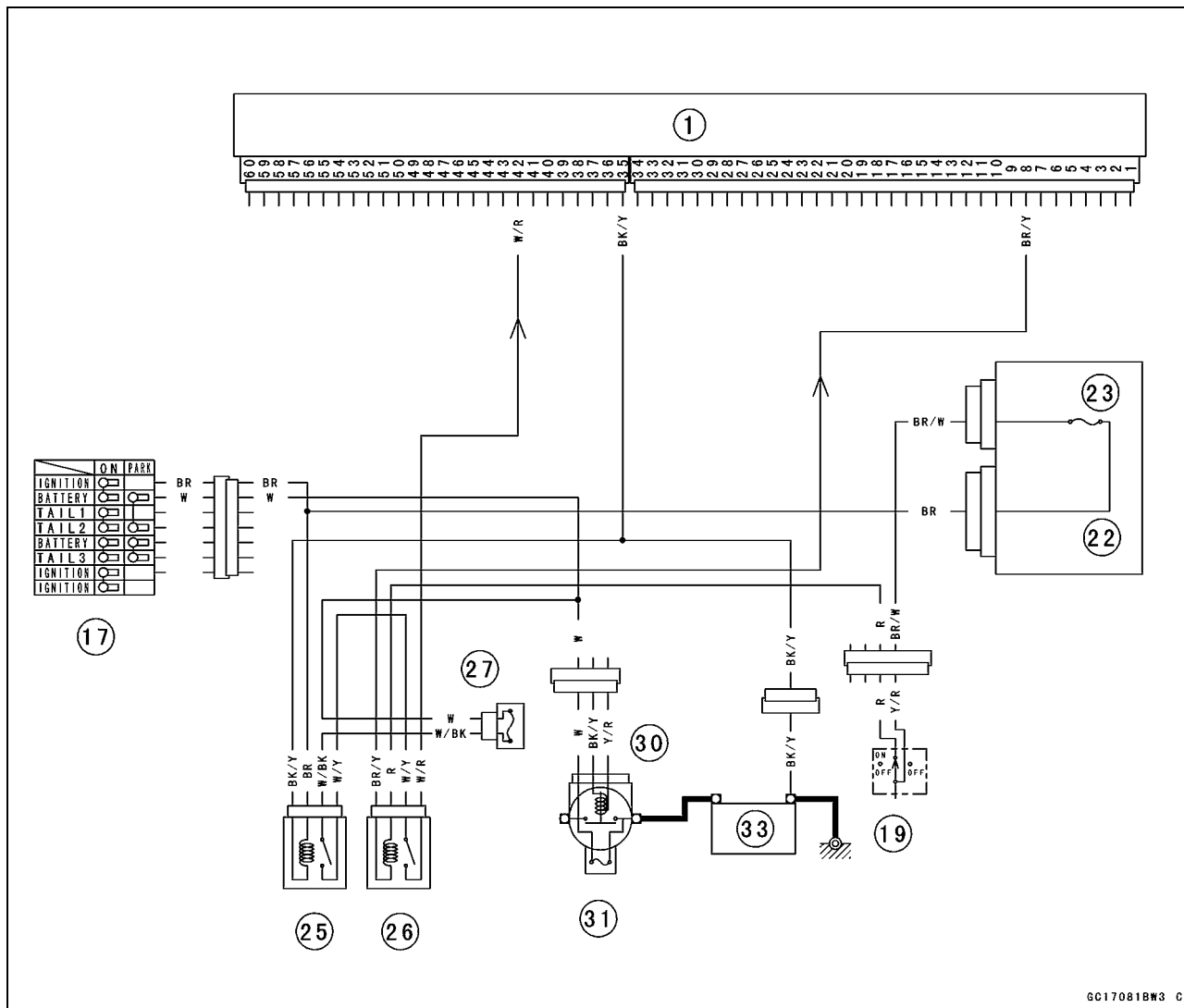

→: Signal

ECU [1]

Ignition Switch [17]

Engine Stop Switch [19]

Junction Box [22]

Ignition Fuse 10 A [23]

ECU Main Relay [25]

Fuel Pump Relay [26]

ECU Fuse 15 A [27]

Starter Relay [30]

Main Fuse 30 A [31]

Battery [33]

3-126 FUEL SYSTEM (DFI)

Fuel Pump Relay (Service Code 45, 46)

ZX1200-B3

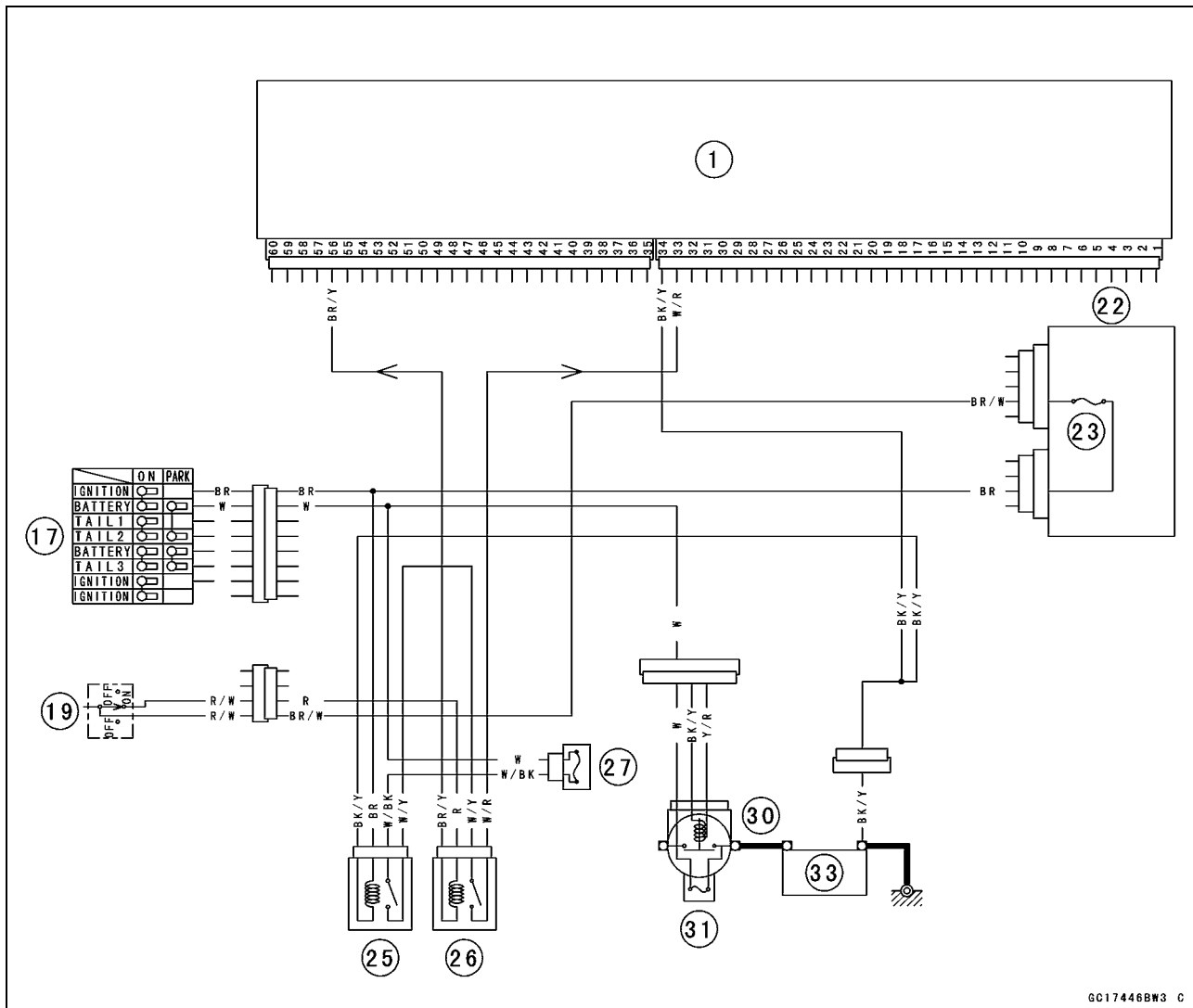

GC17446BW3 C

→: Signal

ECU [1]

Ignition Switch [17]

Engine Stop Switch [19]

Junction Box [22]

Ignition Fuse 10 A [23]

ECU Main Relay [25]

Fuel Pump Relay [26]

ECU Fuse 15 A [27]

Starter Relay [30]

Main Fuse 30 A [31]

Battery [33]

Stick Coils (#1, #2, #3, #4: Service Code 51, 52, 53, 54)

- Stick Coil #1: Ignition Coil (Service Code 51)
- Stick Coil #2: Ignition Coil (Service Code 52)
- Stick Coil #3: Ignition Coil (Service Code 53)
- Stick Coil #4: Ignition Coil (Service Code 54)

Removal/Installation

CAUTION

<p>Never drop the ignition coils, especially on a hard surface. Such a shock to the ignition coil can damage it.</p>

- See Ignition System section in the Electrical System chapter.

Input Voltage Inspection

NOTE

- Be sure the battery is fully charged.

3-128 FUEL SYSTEM (DFI)

Stick Coils (#1, #2, #3, #4: Service Code 51, 52, 53, 54)

- Turn the ignition switch OFF.
- Remove the ECU (see this chapter). Do not disconnect the ECU connector.
- Connect a digital voltmeter [A] as shown, with the needle adapter set [B].
- Measure the input voltage to each primary winding of the ignition coils with the engine stopped, and with the connectors joined.
- Turn the ignition switch ON.

Stick Coil Input Voltage at ECU

ZX1200-B1/B2:

Connections for Stick Coil #1

- Meter (+) → BK lead (terminal 1)
- Meter (-) → BK/Y lead (terminal 26)

Connections for Stick Coil #2

- Meter (+) → BK/G lead (terminal 2)
- Meter (-) → BK/Y lead (terminal 26)

Connections for Stick Coil #3

- Meter (+) → BK/R lead (terminal 3)
- Meter (-) → BK/Y lead (terminal 26)

Connections for Stick Coil #4

- Meter (+) → BK/O lead (terminal 10)
- Meter (-) → BK/Y lead (terminal 26)

ZX1200-B3:

Connections for Stick Coil #1

- Meter (+) → BK lead (terminal 47)
- Meter (-) → BK/Y lead (terminal 59)

Connections for Stick Coil #2

- Meter (+) → BK/G lead (terminal 46)
- Meter (-) → BK/Y lead (terminal 59)

Connections for Stick Coil #3

- Meter (+) → BK/R lead (terminal 45)
- Meter (-) → BK/Y lead (terminal 59)

Connections for Stick Coil #4

- Meter (+) → BK/O lead (terminal 60)
- Meter (-) → BK/Y lead (terminal 59)

Input Voltage at ECU

Standard: Battery Voltage (12.5 V or more)

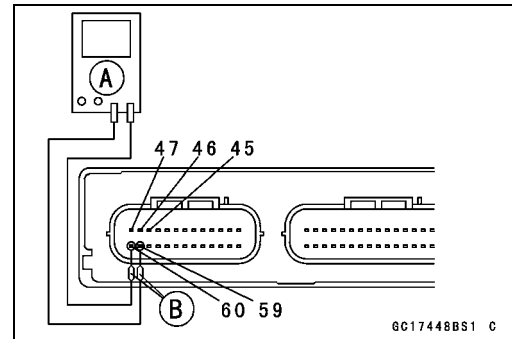
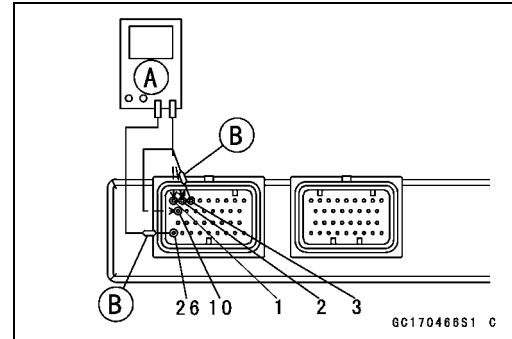

Stick Coils (#1, #2, #3, #4: Service Code 51, 52, 53, 54)

- ★If the reading is out of the standard, check the wiring (see next wiring diagram).
- ★If the reading is good, the input voltage is normal. Crank the engine, and check the peak voltage of the stick coils (see Electrical System chapter) in order to check the primary coils.

ZX1200-B1/B2

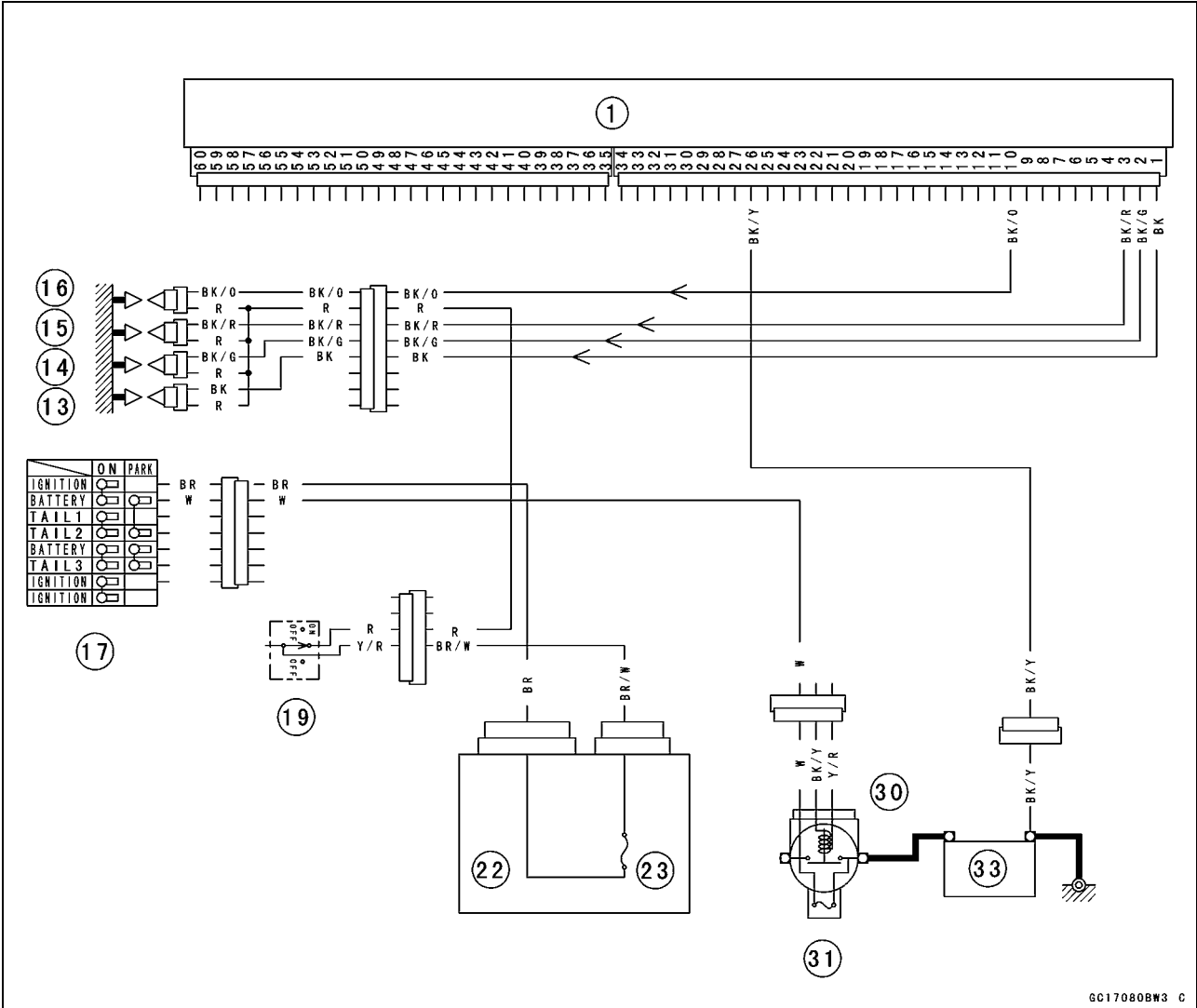

GC17080BW3 C

→: Signal

- | | | |
|--------------------|-------------------------|-------------------------|
| ECU [1] | Stick Coil #4 [16] | Ignition Fuse 10 A [23] |
| Stick Coil #1 [13] | Ignition Switch [17] | Starter Relay [30] |
| Stick Coil #2 [14] | Engine Stop Switch [19] | Main Fuse 30 A [31] |
| Stick Coil #3 [15] | Junction Box [22] | Battery [33] |

3-130 FUEL SYSTEM (DFI)

Stick Coils (#1, #2, #3, #4: Service Code 51, 52, 53, 54)

ZX1200-B3

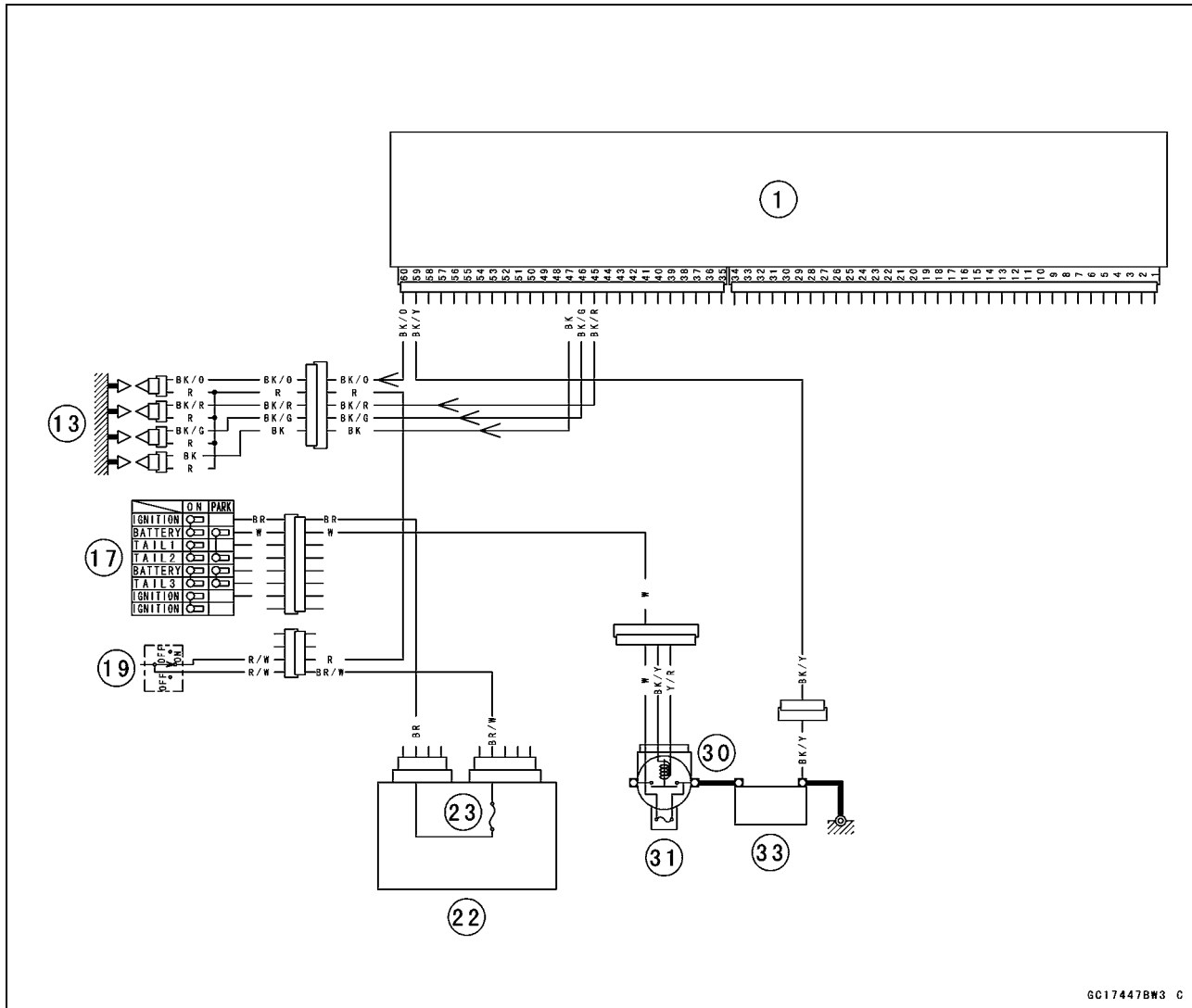

GC17447BW3 C

→: Signal

ECU [1]

Stick Coil #1, #2, #3, #4, [13]

Ignition Switch [17]

Engine Stop Switch [19]

Junction Box [22]

Ignition Fuse 10 A [23]

Starter Relay [30]

Main Fuse 30 A [31]

Battery [33]

Subthrottle Valve Actuator (Service Code 62) (ZX1200-B3)

Subthrottle Valve Actuator Removal

CAUTION

Do not remove the subthrottle valve actuator [A] since it has been adjusted and set with precision at the factory.
Never drop the actuator, especially on a hard surface. Such a shock to the actuator can damage it.

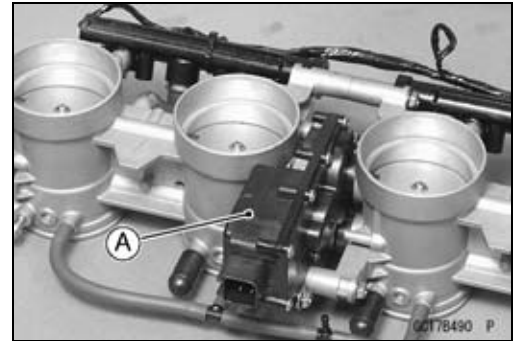

Audible Inspection

NOTE

○Be sure the battery is fully charged.

- Turn the ignition switch ON and ensure that the actuator valves open and close (make light sounds) several times within seconds, and then close at the idle throttle opening position.
- Turn the ignition switch OFF.
- ★ If the actuator does not work as described above, do the visual inspection.

Visual Inspection

- Remove the throttle body assy (see Throttle Body Assy Removal).
- Turn the ignition switch ON.
- Check to see that all the subthrottle valves [A] open and close smoothly.
- ★ If the subthrottle valves do not operate, check the actuator internal resistance (see Resistance Inspection).

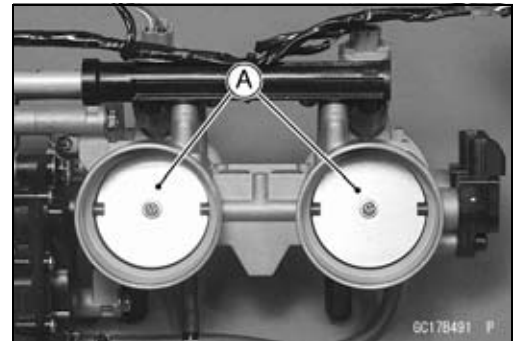

Resistance Inspection

- Turn the ignition switch OFF.
- Disconnect the subthrottle valve actuator connector [A].

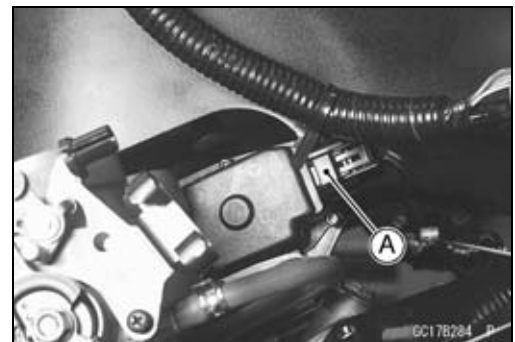

- Connect a digital meter to the subthrottle valve actuator connector [A].
- Measure the subthrottle valve actuator resistance.

Subthrottle Valve Actuator Resistance

Connections: BK/BL lead [1] ↔ P/BL lead [2]
 G lead [3] ↔ W/BL lead [4]

Standard: about 2 ~ 4 kΩ

Special Tool - Hand Tester : 57001-1394

- ★ If the reading is out of the range, replace the actuator along with the throttle body assy.
- ★ If the reading is within the range, check the input voltage (see Input Voltage Inspection).

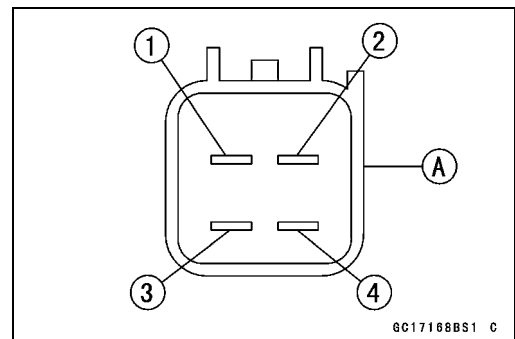

3-132 FUEL SYSTEM (DFI)

Subthrottle Valve Actuator (Service Code 62) (ZX1200-B3)

Input Voltage Inspection

NOTE

○Be sure the battery is fully charged.

- Turn the ignition switch OFF.
- Connect the peak voltage adapter [A] and a digital meter [B] to the connector [C], using the needle adapter set [D].

Recommended Tool - Peak Voltage Adapter

Type: KEK-54-9-B

Brand: KOWA SEIKI

Special Tool - Needle Adapter Set: 57001-1457

Subthrottle Valve Actuator Input Voltage Connections to Harness Connector

- (I) Meter (+) → BK/BL lead [1]
Meter (-) → P/BL lead [2]
- (II) Meter (+) → G lead [3]
Meter (-) → W/BL lead [4]

- Measure the actuator input voltage with the engine stopped, and with the connector joined.
- Turn the ignition switch ON.

Input Voltage at Actuator

Standard: about 10 ~ 14 V DC

- ★ If the reading is within the standard but the actuator doesn't operate, replace it.
- ★ If the reading is out of the range, check the wiring to ECU (see wiring diagram in this section).
- ★ If the wiring is good, check the ECU for its ground and power supply (see ECU section).

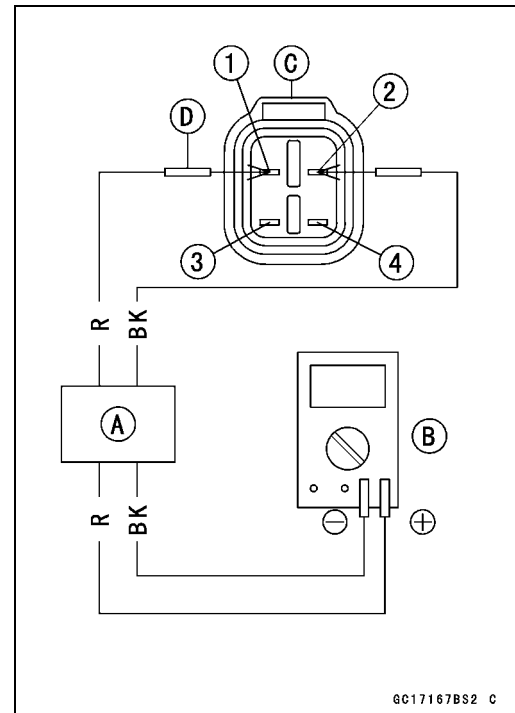

GC17167BS2 C

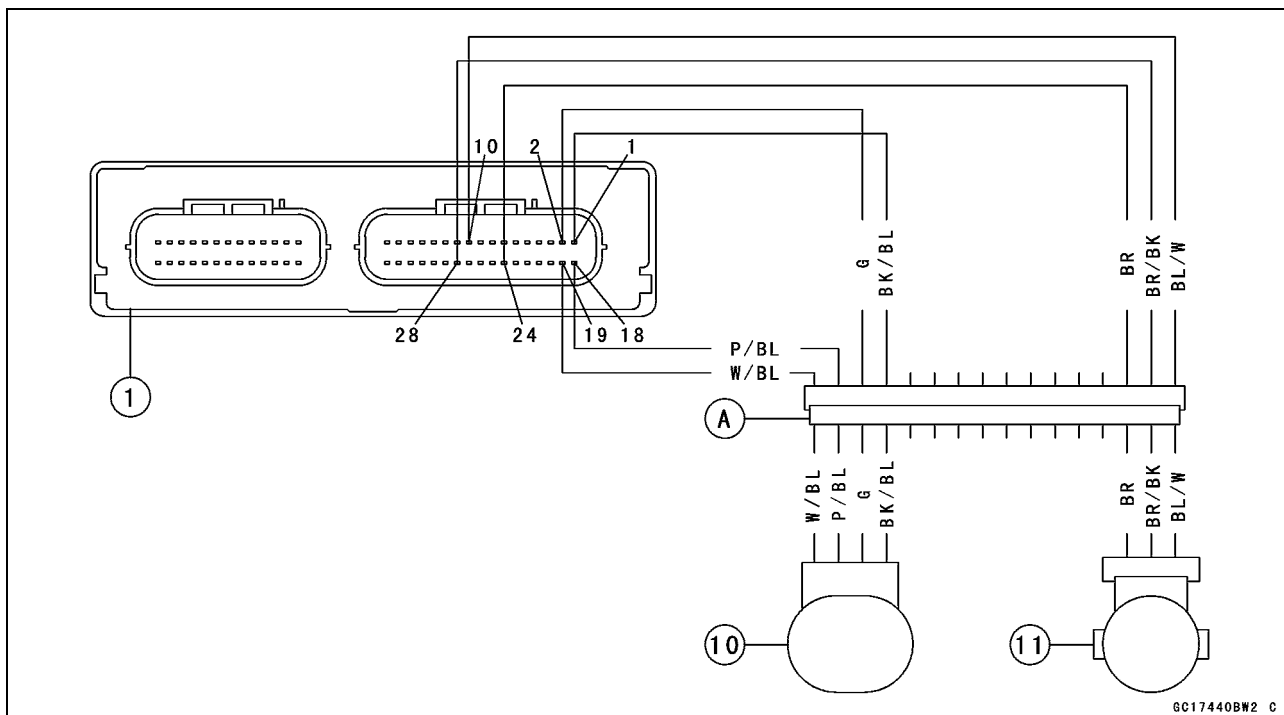

GC17440BW2 C

- 1. ECU
- 10. Subthrottle Valve Actuator
- 11. Subthrottle Sensor
- A. Throttle Body Assy Connector

ECU

CAUTION

Never drop the ECU, especially on a hard surface. Such a shock to the ECU can damage it.

ECU Removal

- Remove:
 - Rear Seat with Cover (see Frame chapter)
 - Storage Box (see Frame chapter)
- Pull the ECU [A] out.
- ★If necessary, disconnect the connectors [B].
- Refer to the Electrical System chapter for Europe model.

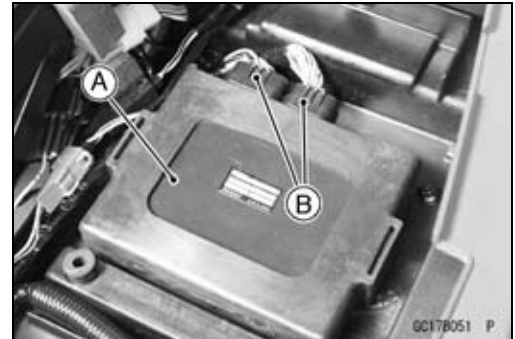

ECU Installation

- Connect the ECU connectors.
- ★If the rubber protector [A] is removed, install it. ECU [B]

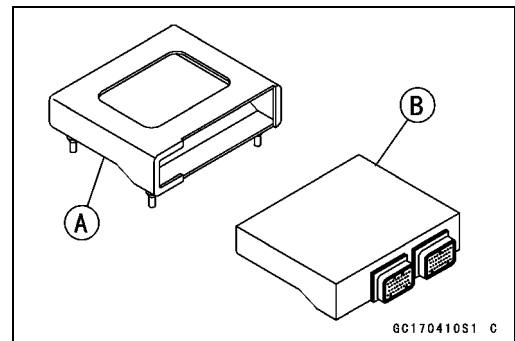

- Insert the projections [A] of the rubber protector into the holes [B] of the rear fender rear.

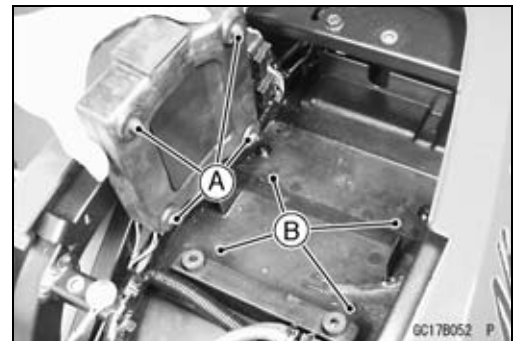

ECU Power Supply Inspection

- Visually inspect the terminals [A] of the ECU connectors.
- ★If the connector is clogged with mud or dust, blow it off with compressed air.
- ★Replace the main harness if the terminals of the main harness connectors are cracked, bent, or otherwise damaged.
- ★Replace the ECU if the terminals of the ECU connectors are cracked, bent, or otherwise damaged.



3-134 FUEL SYSTEM (DFI)

ECU

- With the ECU connectors [A] connected, check the following ground lead for continuity with the ignition switch OFF, using the hand tester and needle adapter set.

ECU Grounding Inspection

ZX1200-B1/B2:

18, 26, 27, or 35 (BK/Y) Terminal \longleftrightarrow

Battery (-) Terminal: 0 Ω

54 (BR/BK) Terminal \longleftrightarrow

Battery (-) Terminal: 0 Ω

Engine Ground Terminal [B] \longleftrightarrow

Battery (-) Terminal: 0 Ω

ZX1200-B3:

34, 58 or 59 (BK/Y) Terminal \longleftrightarrow

Battery (-) Terminal: 0 Ω

28 (BR/BK) Terminal \longleftrightarrow

Battery (-) Terminal: 0 Ω

Engine Ground Terminal [B] \longleftrightarrow

Battery (-) Terminal: 0 Ω

- ★If no continuity, check the connector, the engine ground lead, or main harness, and repair or replace them if necessary.

Battery [C] in the Frame

Special Tools - Hand Tester [D]: 57001-1394

Needle Adapter Set: 57001-1457

ZX1200-B1/B2

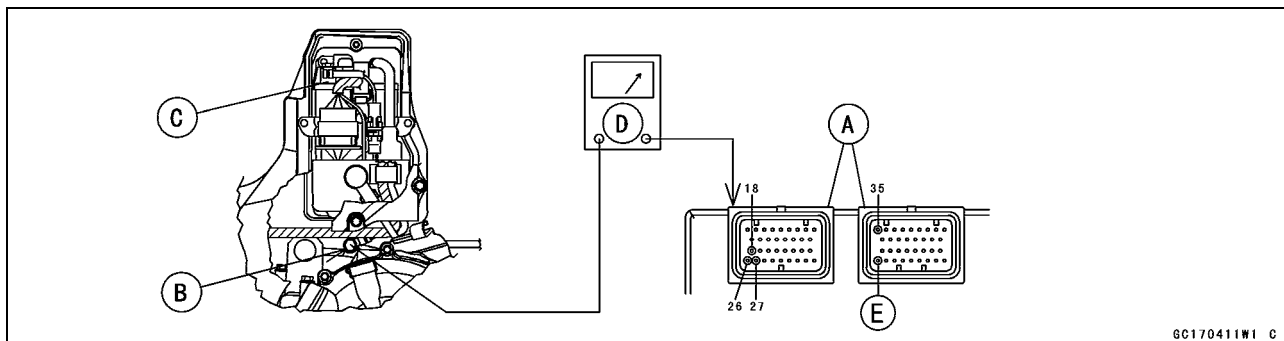

[E]: Terminal No.54

ZX1200-B3

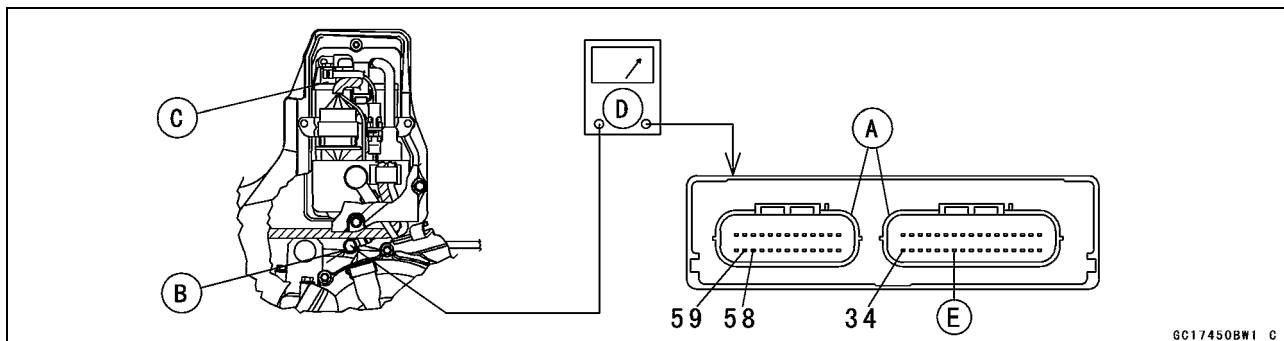

[E]: Terminal No.28

ECU

- Check the ECU power source voltage with the hand tester.
- Position the terminal in accordance with terminal numbers of ECU connectors in this chapter figure.

ECU Power Source Inspection

ZX1200-B1/B2:

- Tester Connections:** between 17 (W/Y) Terminal and Battery (-) Terminal
between 48 (W) Terminal and Battery (-) Terminal
- Ignition SW OFF:** 17 (W/Y) Terminal 0 V, 48 (W) Terminal 12.5 V or more
- Ignition SW ON:** Battery Voltage (12.5 V or more)

ZX1200-B3:

- Tester Connections:** between 17 (W/Y) Terminal and Battery (-) Terminal
between 16 (W) Terminal and Battery (-) Terminal
- Ignition SW OFF:** 17 (W/Y) Terminal 0 V, 16 (W) Terminal 12.5 V or more
- Ignition SW ON:** Battery Voltage (12.5 V or more)

- ★ If the tester does not read as specified, check the following:
 - Power Source Wiring (see wiring diagram below)
 - ECU Fuse 15 A (see DFI Power Source section)
 - ECU Main Relay (see DFI Power Source section)
 - Ignition Fuse 10 A (see Electrical System chapter)
 - Main Fuse 30 A (see Electrical System chapter)
- ★ If the inspection checks good, the ECU is damaged. Replace the ECU. The ECU itself cannot be checked or serviced.

3-136 FUEL SYSTEM (DFI)

ECU

ECU Power Source Circuit ZX1200-B1/B2

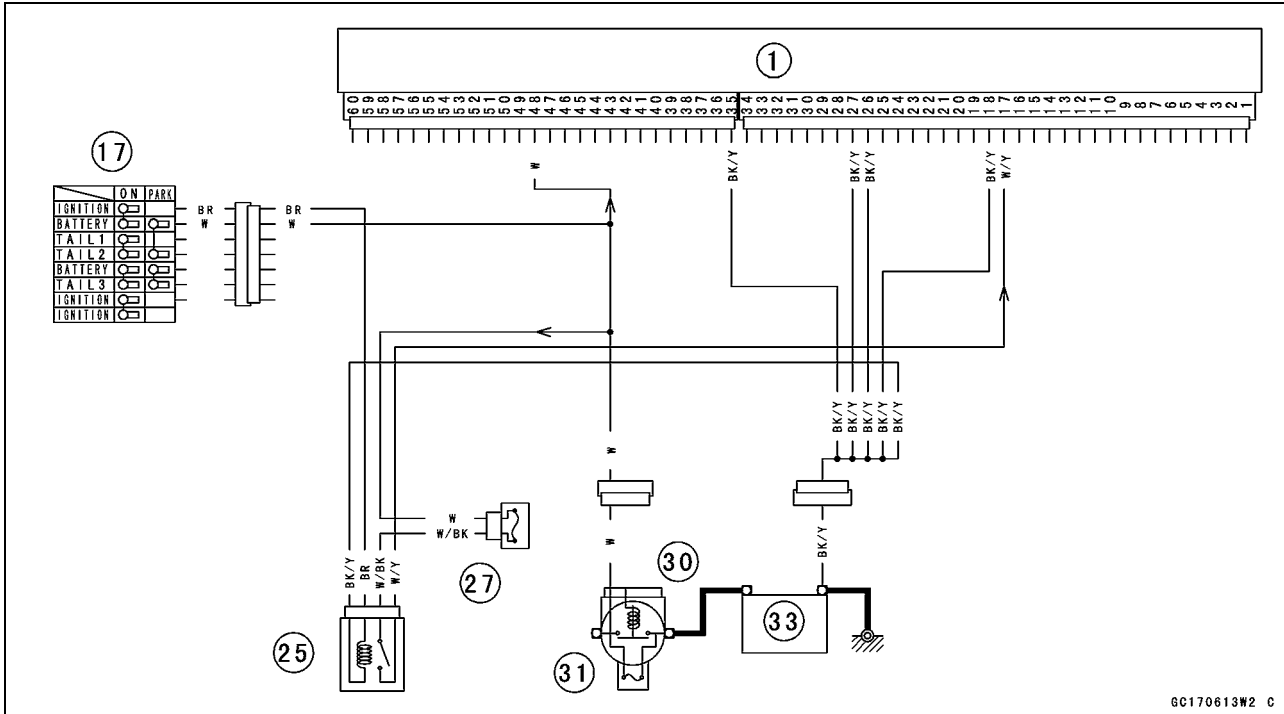

GC170613W2 C

→: Current

ECU [1]

Ignition Switch [17]

ECU Main Relay [25]

ECU Main Fuse 15 A [27]

Starter Relay [30]

Main Fuse 30 A [31]

Battery [33]

ZX1200-B3

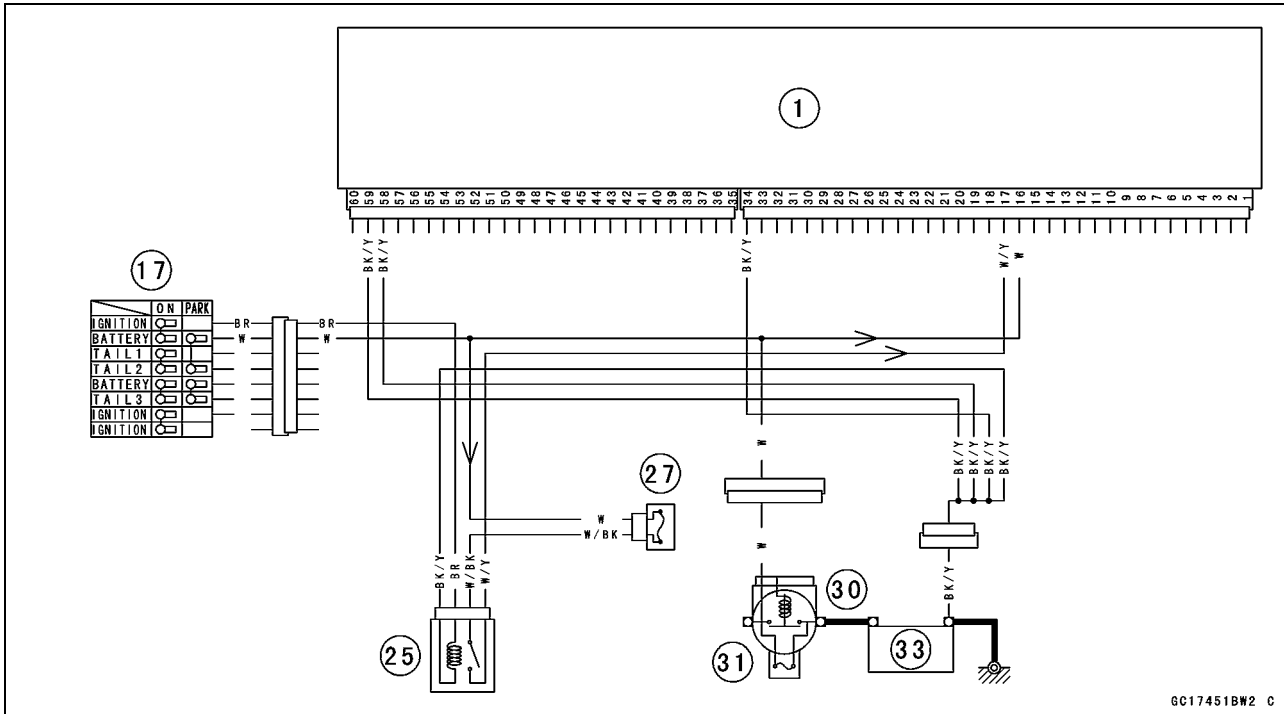

GC17451BW2 C

→: Current

ECU [1]

Ignition Switch [17]

ECU Main Relay [25]

ECU Main Fuse 15 A [27]

Starter Relay [30]

Main Fuse 30 A [31]

Battery [33]

DFI Power Source

ECU Fuse Removal

- Refer to the Electrical System chapter for the ECU fuse removal.

ECU Fuse Installation

- ★ If a fuse fails during operation, inspect the DFI system to determine the cause, and then replace it with a new fuse of proper amperage.
- Refer to the Electrical System chapter for the ECU fuse installation.

ECU Fuse Inspection

- Refer to the Electrical System chapter for the ECU Fuse Inspection.

ECU Main Relay Removal

CAUTION

Never drop the relay, especially on a hard surface. Such a shock to the relay can damage it.

- Remove:
 - Fuel Tank Cover (see Fuel Tank Removal)
 - Bracket Bolt [A]
- Remove the ECU fuse [B].
- Pull out the ECU main relay [C] from the bracket and disconnect the connector.

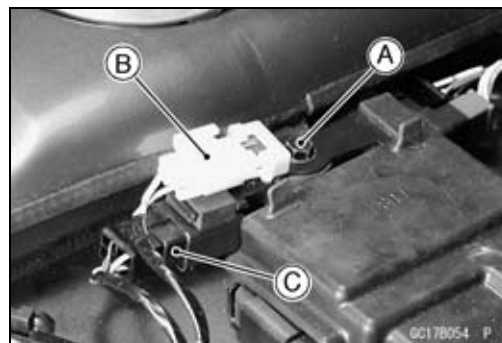

ECU Main Relay Inspection

- Remove the ECU main relay (see above).
- Connect the hand tester [A] and one 12 V battery [B] to the relay connector [C] as shown.

Special Tool - Hand Tester: 57001-1394

- Relay Coil Terminals [1] and [2]
- Relay Switch Terminals [3] and [4]

Testing Relay

Tester range: 1 Ω range

Criteria: When battery is connected → 0 Ω
When battery is disconnected → ∞ Ω

★ If the relay does not work as specified, replace the relay.

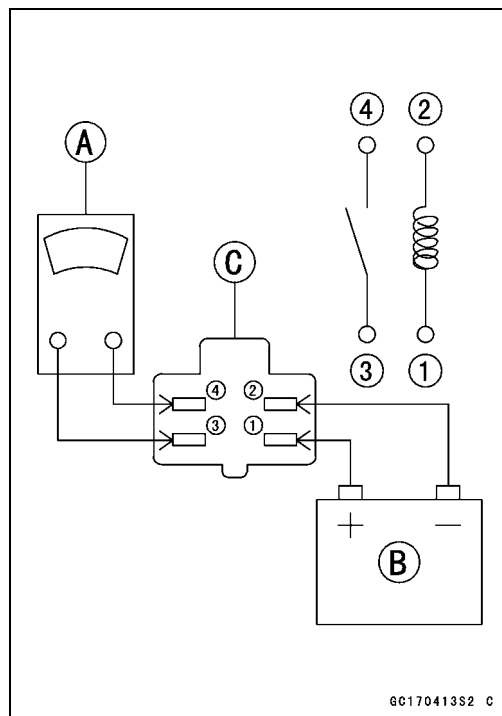

3-138 FUEL SYSTEM (DFI)

FI Indicator LED Light

Inspection Flow Chart

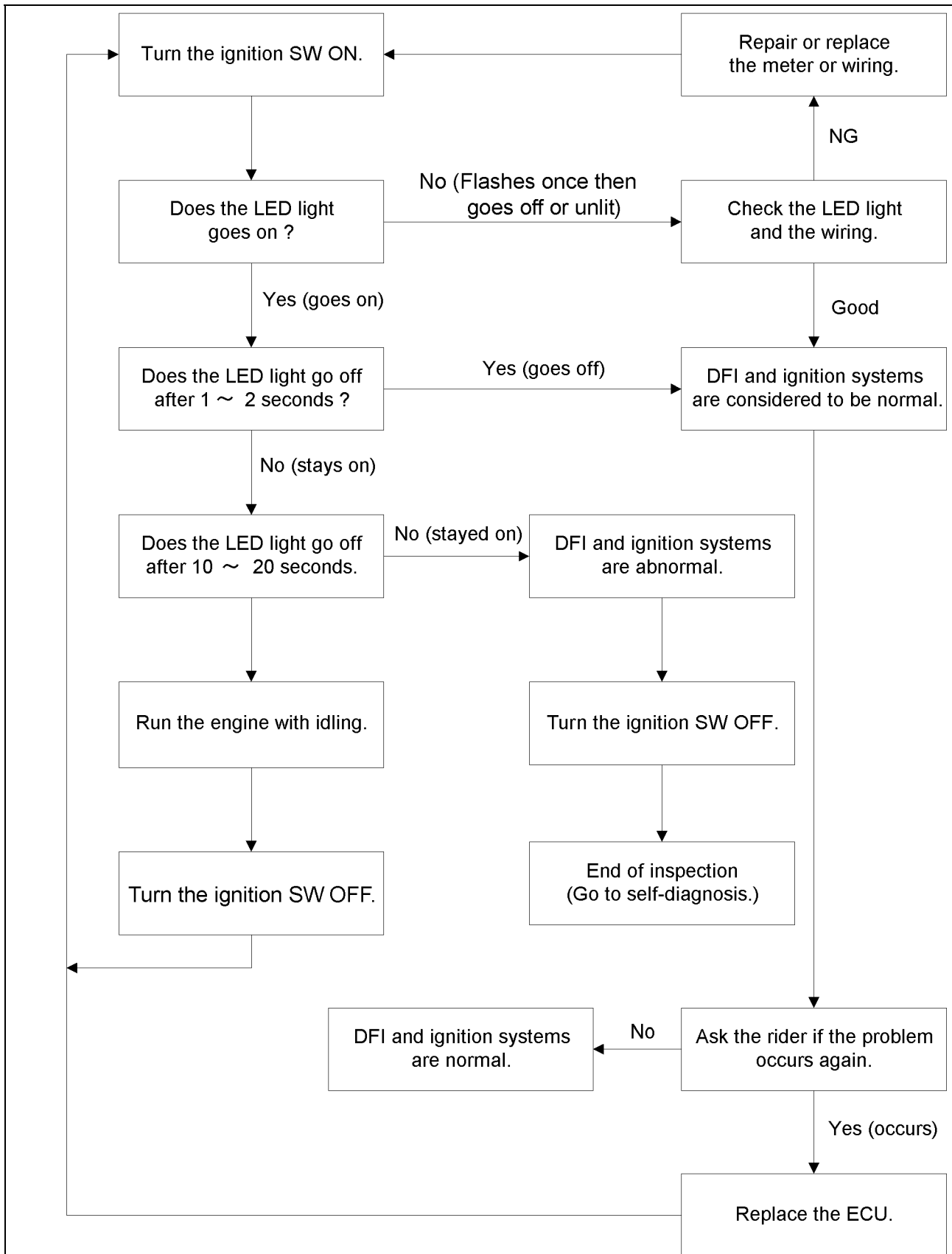

FI Indicator LED Light

LED Light Inspection

- Remove the meter unit (see Electrical System chapter).
 - Using two auxiliary leads, supply battery power to the FI indicator LED light [A].
- 12 V Battery [B]

FI Indicator LED Light Check

- Connector:** Meter Connector [C] (disconnected)
- Connection:** BR/W Lead Terminal [14] of the Meter → Battery (+) Terminal
- BR/R Lead Terminal [20] of the Meter → Battery (-) Terminal
- Criterion:** The LED light should light.

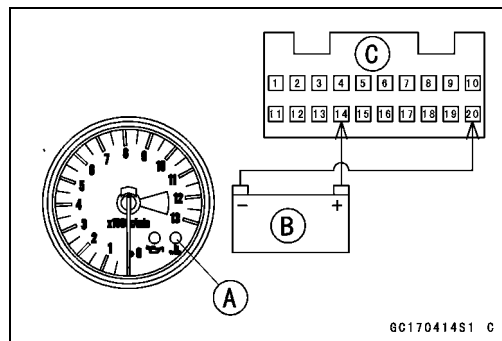

- ★ If the LED light does not go on, replace the meter unit.
- ★ If the FI indicator LED light goes on, the wiring or ECU has trouble. Check the wiring (see next diagram). If the wiring is good, replace the ECU.

ZX1200-B1/B2

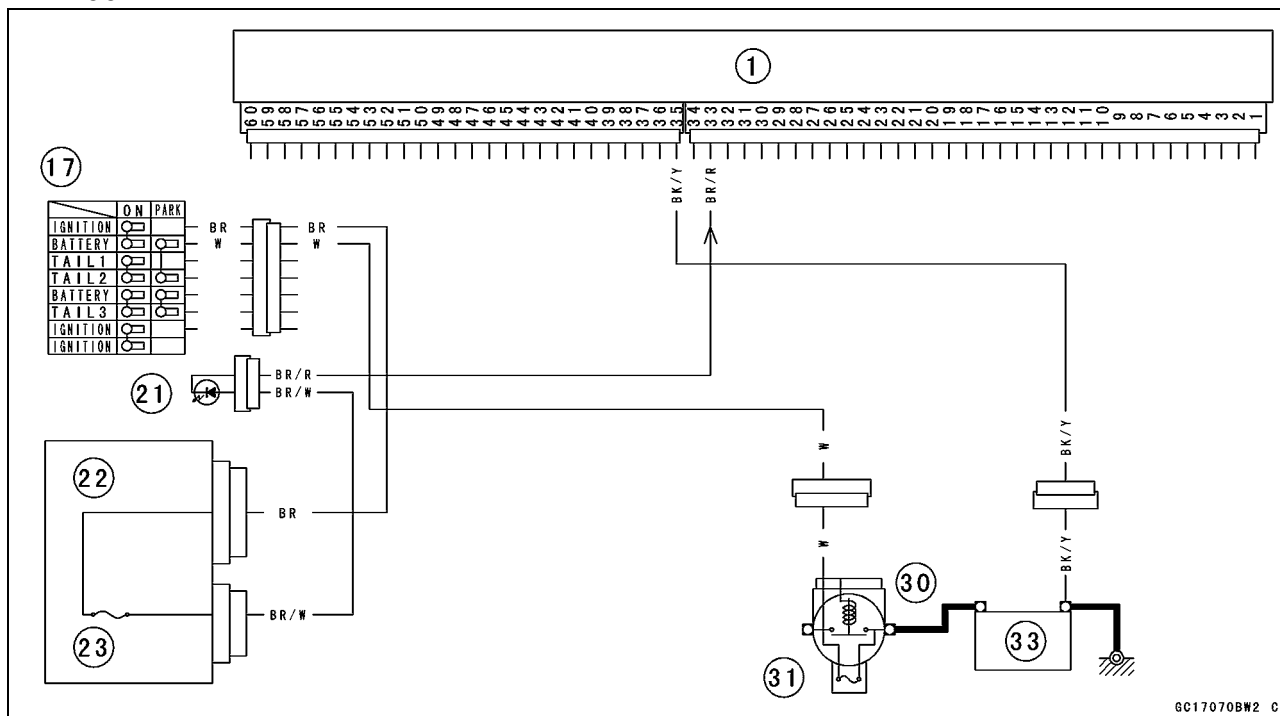

→: Signal

ECU [1]

Ignition Switch [17]

FI Indicator LED Light [21]

Junction Box [22]

Ignition Fuse 10 A [23]

Starter Relay [30]

Main Fuse 30 A [31]

Battery [33]

3-140 FUEL SYSTEM (DFI)

FI Indicator LED Light

ZX1200-B3

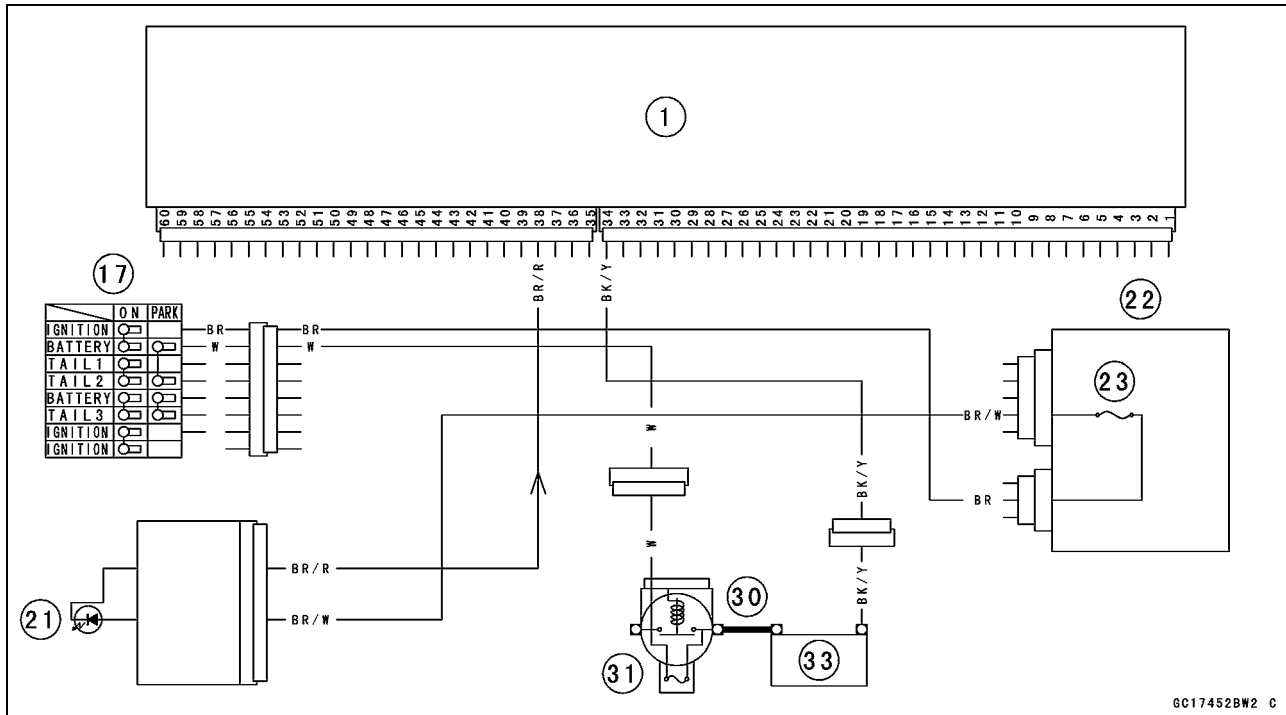

GC17452BW2 C

→: Signal

ECU [1]

Ignition Switch [17]

FI Indicator LED Light [21]

Junction Box [22]

Ignition Fuse 10 A [23]

Starter Relay [30]

Main Fuse 30 A [31]

Battery [33]

Fuel Line

Fuel Pressure Inspection

NOTE

○Be sure the battery is fully charged.

- Remove:
 - Fuel Tank Cover (see Fuel Tank Removal)
 - Be sure to place a piece of cloth around the fuel supply pipe of the throttle body assy.
 - Loosen the clamp bolt and pull out the fuel supply hose [A].
- Quickly plug the pipe with a plug.

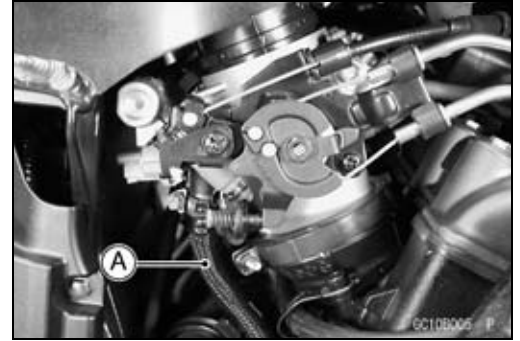

⚠ WARNING

Be prepared for fuel spillage; any spilled fuel must be completely wiped up immediately. When the fuel hose is disconnected, fuel spills out from the hose and the pipe because of residual pressure. Cover the hose connection with a piece of clean cloth to prevent fuel spillage.

- Install the fuel pressure gauge adapter [A] between the fuel supply pipe [B] and the fuel supply hose [C].
- Connect the pressure gauge [D] to the fuel pressure gauge adapter.

**Special Tools - Oil Pressure Gauge: 57001-125
Fuel Pressure Gauge Adapter: 57001-1417**

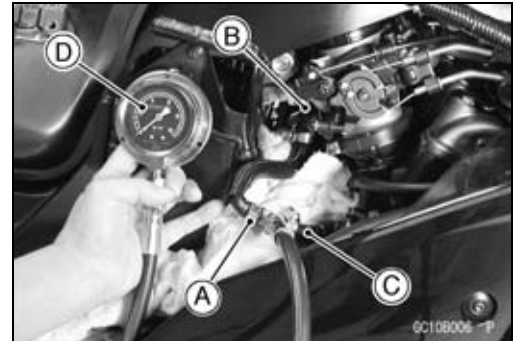

⚠ WARNING

Do not try to start the engine with the fuel hoses disconnected.

- Turn the ignition switch ON. The fuel pump will turn for 3 seconds, and then stop.

CAUTION

Do not drive the fuel pump 3 seconds or more without the fuel in the fuel tank. If the fuel pump is driven without the fuel, it may be damaged.

- Measure the fuel pressure with the engine stopped.

Fuel Pressure

right after Ignition SW ON, with pump running for 3 seconds:

Standard: 285 ~ 315 kPa (2.91 ~ 3.21 kgf/cm², 41 ~ 46 psi)

NOTE

○The gauge hand will fluctuate. Read the pressure at the average of the maximum and minimum indications.

3-142 FUEL SYSTEM (DFI)

Fuel Line

- ★ If the fuel pressure is much higher than the specified, check the following:
 - Fuel Return Hose for Sharp Bend, Kinking, or Clogging
 - ★ If the fuel pressure is much lower than specified, check the following:
 - Fuel Line Leakage
 - Amount of Fuel Flow (see Fuel Flow Rate Inspection)
 - ★ If the fuel pressure is much lower than specified, and if inspection above checks out good, replace the throttle body assy, or the fuel pump and measure the fuel pressure again
 - Remove the fuel pressure gauge and adapter.
 - Run the fuel hoses in accordance with the Cable, Wire, and Hose Routing section in the General Information chapter.
- Torque - Fuel Hose Clamp Bolts: 1.5 N·m (0.15 kgf·m, 13 in·lb)**

Fuel Flow Rate Inspection

NOTE

○ Be sure the battery is fully charged.

⚠ WARNING

Gasoline is extremely flammable and can be explosive under certain conditions. Make sure the area is well-ventilated and free from any source of flame or sparks; this includes any appliance with a pilot light. Do not smoke. Turn the ignition switch OFF. Be prepared for fuel spillage; any spilled fuel must be completely wiped up immediately.

- Turn the ignition switch, and engine stop switch OFF.
- Wait until the engine cools down.
- Set up the fuel tank (see this chapter).
- Open the fuel tank cap [A] to lower the pressure in the tank.
Front [B]



Fuel Line

- Prepare a measuring cylinder [A].
- Disconnect the fuel supply hose [B] from the fuel outlet pipe [C], and plug the outlet pipe with the rubber plug quickly.
- Connect the fuel pressure gauge adapter [D], and the measuring cylinder as shown.

Special Tool - Fuel Pressure Gauge Adapter: 57001-1417

- Close the fuel tank cap.

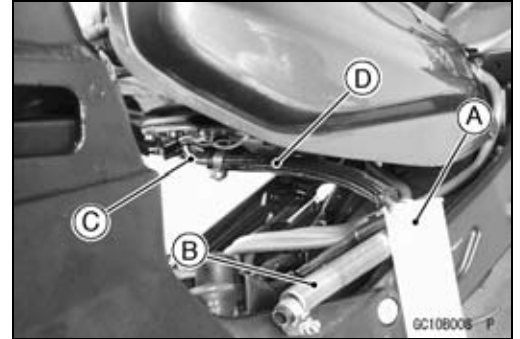

⚠ WARNING

**Wipe off spilled out fuel immediately.
Be sure to hold the measuring cylinder vertical.**

- With the engine stopped, turn the ignition switch ON. The fuel pump should operate for 3 seconds, and then should stop.

CAUTION

Do not drive the fuel pump 3 seconds or more without the fuel in the fuel tank. If the fuel pump is driven without the fuel, it may be damaged.

- Measure the discharge for 3 seconds.
- Measure the fuel flow rate so that the adapter hose filled with fuel.

Amount of Fuel Flow

Standard: 83 mL (2.8 US oz) or more for 3 seconds

- ★ If the fuel flow is much less than the specified, check the following:
 - Fuel Pump (see Fuel Pump Inspection in this chapter)
 - Pump Filter (see Pump Filter Cleaning in the In-tank Fuel Pump section).
- After inspection, connect the fuel hoses. (see Fuel Tank Installation).
- Start the engine and check for fuel leakage.

3-144 FUEL SYSTEM (DFI)

In-tank Fuel Pump

Fuel Pump Removal

CAUTION

Never drop the fuel pump, especially on a hard surface. Such a shock to the pump can damage it.

⚠ WARNING

Gasoline is extremely flammable and can be explosive under certain conditions. Make sure the area is well-ventilated and free from any source of flame or sparks; this includes any appliance with a pilot light. Do not smoke. Turn the ignition switch OFF. Disconnect the battery (–) terminal.

To make fuel spillage minimum, draw the fuel out from the fuel tank when the engine is cold. Be prepared for fuel spillage; any spilled fuel must be completely wiped up immediately.

- Draw the fuel out from the fuel tank (see Fuel Tank Removal).
- Remove the fuel tank (see this chapter).
- Be careful of fuel spillage from the fuel tank since fuel still remains in the fuel tank and fuel pump. Plug the fuel pipe of the fuel tank.

- Push down the stopper [A], using the (–) screw driver [B].
- Remove the fuel level sensor connector [C].

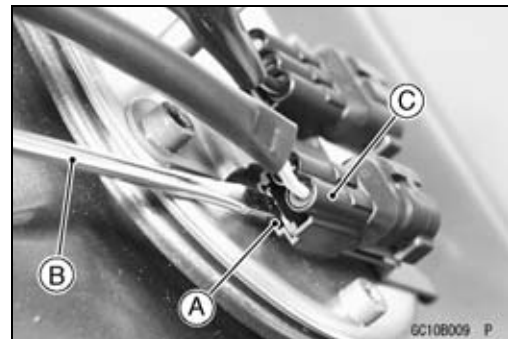

- Turn the fuel tank upside down.
- Unscrew the fuel pump bolts [A], and take out the fuel pump assembly [B] and gasket.
- Discard the fuel pump gasket.

CAUTION

Do not pull the leads (C) of the fuel pump and fuel reserve switch. If they are pulled, the lead terminals may be damaged.

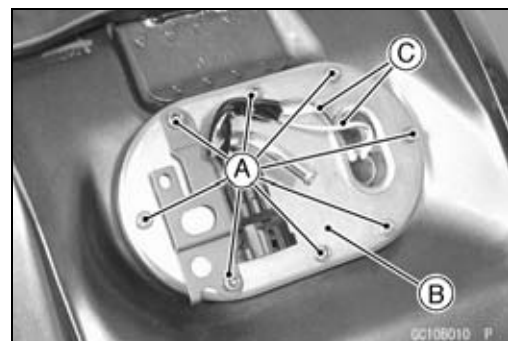

In-tank Fuel Pump

Pump Screen Cleaning

⚠ WARNING

Clean the pump screw in a well-ventilated area, and take care that there are no sparks or flame anywhere near the working area. Because of the danger of highly flammable liquids, do not use gasoline or low-flash point solvent to clean the pump screen.

- Remove the fuel pump [A] along with the pump screen [B].
- Prepare a container [C] filled with a high-flash point solvent.
- Dip and shake the pump in the solvent to remove dirt and fuel deposits from the pump screen.
- Dry the pump and screen by lightly applying compressed air.
- Replace the fuel pump gasket with a new one.
- Install the fuel pump (see this section).

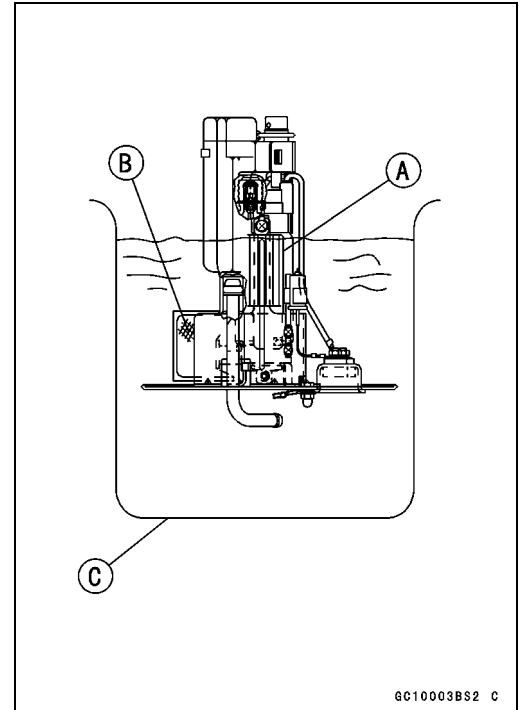

GC10003BS2 C

Fuel Pump Installation

- Clean the pump screen (see Pump Filter Cleaning).
- Remove dirt or dust from the fuel pump [A] by lightly applying compressed air.
- Replace the fuel pump gasket with a new one.

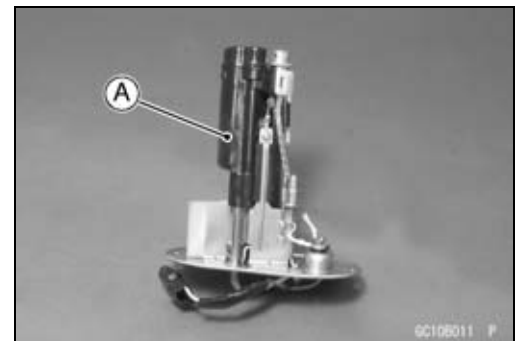

GC106011 F

- Check that the fuel pump terminals are in place.
 Pump Motor and Fuel Reserve Switch BK/W (-) Lead [A]
 Pump Motor Y/R (+) Lead [C]
 Fuel Reserve Switch R/BK (+) Lead [B]
- Apply a non-permanent locking agent to the threads of the fuel pump bolts.
- Tighten the fuel pump bolts to a snug fit following the tightening sequence shown.
- Install the fuel pump bolts [3, 4] with the bracket [D].
- Following the tightening sequence, tighten the pump bolts to the specified torque.

Torque - Fuel Pump Bolts: 6.9 N·m (0.70 kgf·m, 61 in·lb)

- Tighten the pump bolts again to check the tightness in the order shown.

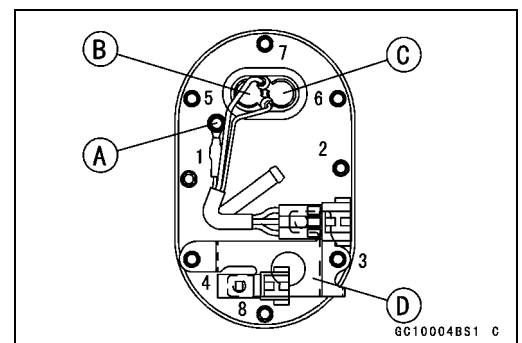

GC10004BS1 C

3-146 FUEL SYSTEM (DFI)

In-tank Fuel Pump

- Secure the fuel level sensor connector [A], and fuel pump connector [B] on the bracket.
- Install the fuel tank (see this chapter).

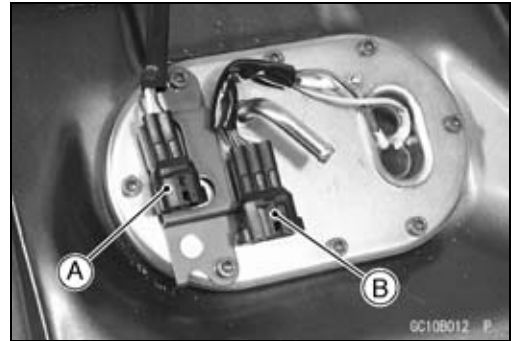

Operation Inspection

NOTE

○Be sure the battery is fully charged.

- Turn the ignition switch ON and make sure that the fuel pump operates (make light sounds) for 3 seconds, and then stops.
- Turn the ignition switch OFF.
- ★If the pump does not work as described above, inspect the operating voltage.

Operating Voltage Inspection

NOTE

○Be sure the battery is fully charged.

- Turn the ignition switch OFF.
- Set up the fuel tank.
- Connect the hand tester [A] (25 V DC) to the connectors, with needle adapter set [B].

Special Tools - Hand Tester: 57001-1394

Needle Adapter Set: 57001-1457

- Measure the operating voltage with the engine stopped, and with the connector joined.
- Turn the ignition switch ON.
- The tester needle should indicate battery voltage for 3 seconds, and then 0 V.

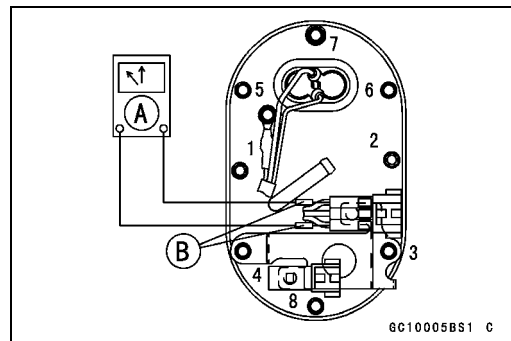

Pump Operating Voltage at Pump

Connections to Pump Connectors

Tester (+) → Y/R Lead

Tester (-) → BK/W Lead

Operating Voltage at Pump Connector

Standard: Battery Voltage (12.5 V or more for 3 seconds, and then 0 V.)

- ★If the reading stays on battery voltage, and never shows 0 V. Check the ECU and fuel pump relay.
- ★If the voltage is in specification, but the pump doesn't work, replace the pump.
- ★If there is still no battery voltage, check the pump relay (see this chapter).

In-tank Fuel Pump

ZX1200-B1/B2

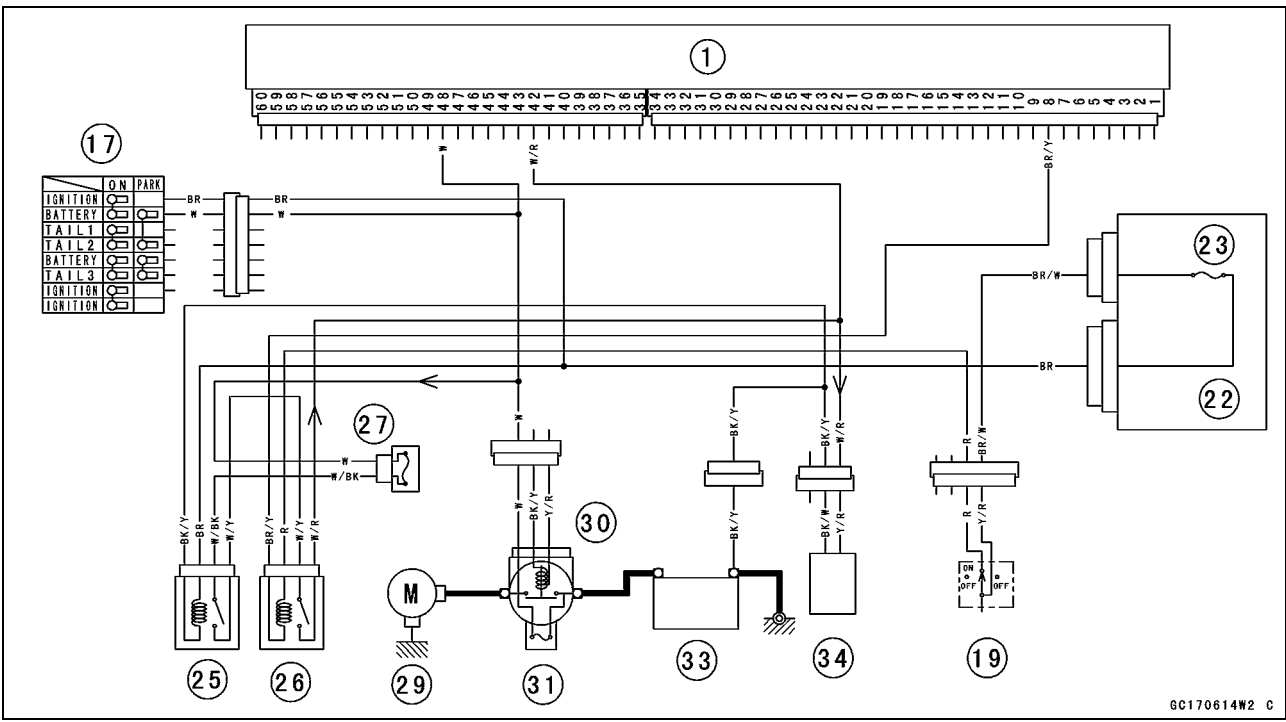

GC170614W2 C

- : Current
- ECU [1]
- Ignition Switch [17]
- Engine Stop Switch [19]
- Junction Box [22]
- Ignition Fuse 10 A [23]
- ECU Main Relay [25]
- Fuel Pump Relay [26]
- ECU Main Fuse 15 A [27]
- Starter Motor [29]
- Starter Relay [30]
- Main Fuse 30 A [31]
- Battery [33]
- Fuel Pump [34]

3-148 FUEL SYSTEM (DFI)

In-tank Fuel Pump

ZX1200-B3

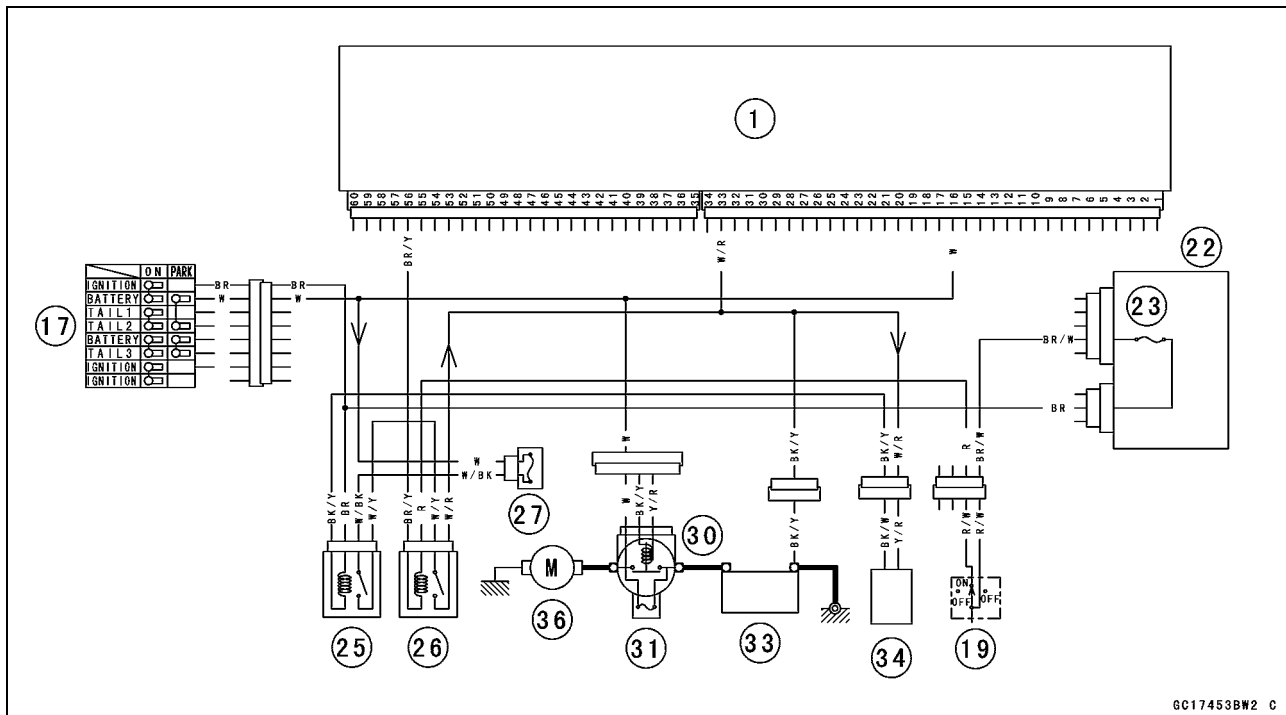

→: Current

ECU [1]

Ignition Switch [17]

Engine Stop Switch [19]

Junction Box [22]

Ignition Fuse 10 A [23]

ECU Main Relay [25]

Fuel Pump Relay [26]

ECU Main Fuse 15 A [27]

Starter Relay [30]

Main Fuse 30 A [31]

Battery [33]

Fuel Pump [34]

Starter Motor [36]

Evaporative Emission Control System

The Evaporative Emission Control System routes fuel vapors from the fuel system into the running engine or stores the vapors in a canister when the engine is stopped. Although no adjustments are required, a thorough visual inspection must be made at the intervals specified by the Periodic Maintenance Chart.

Parts Removal/Installation

⚠ WARNING

Gasoline is extremely flammable and can be explosive under certain conditions. Turn the ignition switch OFF. Do not smoke. Make sure the area is well-ventilated and free from any source of flame or sparks; this includes any appliance with a pilot light.

CAUTION

If gasoline, solvent, water or any other liquid enters the canister, the canister's vapor absorbing capacity is greatly reduced. If the canister does become contaminated, replace it with a new one.

- To prevent the gasoline from flowing into or out of the canister, hold the separator perpendicular to the ground.
- Connect the hoses according to the diagram of the system. Make sure they do not get pinched or kinked.

Hose Inspection

- Refer to the Evaporative Emission Control Stem Inspection in the Periodic Maintenance chapter.

Separator Inspection

- Refer to the Evaporative Emission Control Stem Inspection in the Periodic Maintenance chapter.



3-150 FUEL SYSTEM (DFI)

Evaporative Emission Control System

Separator Operation Test

⚠ WARNING

Gasoline is extremely flammable and can be explosive under certain conditions. Turn the ignition switch OFF. Do not smoke. Make sure the area is well-ventilated and free from any source of flame or sparks; this includes any appliance with a pilot light.

- Connect the hoses to the separator, and install the separator on the motorcycle.
- Disconnect the breather hose from the separator, and inject about 20 mL (0.68 US oz) of gasoline [A] into the separator [B] through the hose fitting.
- Disconnect the fuel return hose [C] from the fuel tank [D].
- Run the open end of the return hose into the container and hold it level with the tank top [E].
- Start the engine, and let it idle.
- ★ If the gasoline in the separator comes out of the hose, the separator works well. If it does not, replace the separator with a new one.

Canister Inspection (California Model Only)

- Refer to the Evaporative Emission Control System Inspection in the Periodic Maintenance chapter.

NOTE

- The canister is designed to work well through the motorcycle's life without any maintenance if it is used under normal conditions.

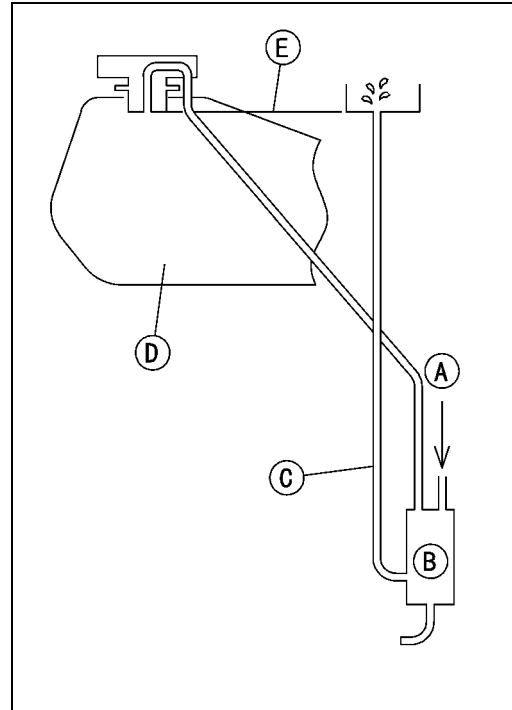

Cooling System

Table of Contents

Exploded View.....	4-2
Specifications	4-3
Coolant Flow Chart.....	4-4
Coolant	4-6
Coolant Deterioration Inspection.....	4-6
Coolant Level Inspection.....	4-6
Coolant Draining	4-6
Coolant Filling	4-6
Pressure Testing	4-7
Cooling System Flushing	4-7
Water Pump.....	4-8
Water Pump Removal.....	4-8
Water Pump Installation.....	4-9
Water Pump Impeller Disassembly/Assembly	4-9
Water Pump Inspection.....	4-9
Water Pump Impeller Inspection	4-10
Water Pump Housing Disassembly	4-10
Water Pump Housing Assembly	4-10
Mechanical Seal Inspection	4-11
Radiator, Radiator Fan	4-12
Radiator and Radiator Fan Removal	4-12
Radiator and Radiator Fan Installation	4-13
Radiator Inspection	4-13
Radiator Cap Inspection	4-14
Thermostat	4-15
Thermostat Removal.....	4-15
Thermostat Installation.....	4-15
Thermostat Inspection	4-15
Hose and Pipes	4-17
Hose Installation	4-17
Hose Inspection	4-17
Radiator Fan Switch, Water Temperature Sensor	4-18
Radiator Fan Switch, Water Temperature SensorRemoval	4-18
Radiator Fan Switch, Water Temperature SensorInstallation	4-18
Radiator Fan Switch, Water Temperature SensorInspection	4-18

4-2 COOLING SYSTEM

Exploded View

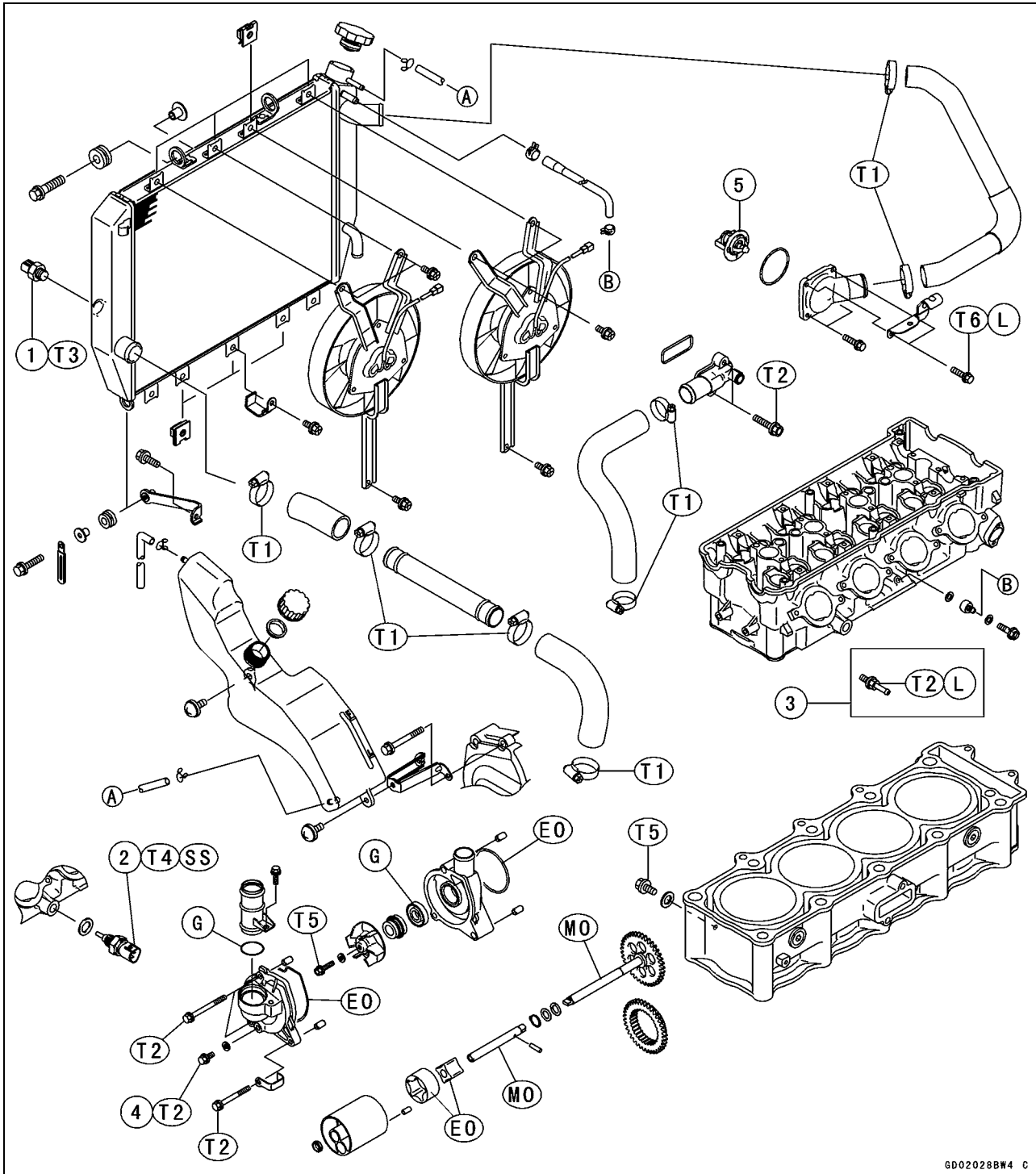

GD02028BW4 C

- 1. Radiator Fan Switch
- 2. Water Temperature Sensor
- 3. Coolant By-pass Fitting (ZX1200-B1/B2)
- 4. Drain Plug
- 5. Thermostat
- T1: 2.0 N·m (0.20 kgf·m, 18 in·lb)
- T2: 12 N·m (1.2 kgf·m, 106 in·lb)
- T3: 24 N·m (2.4 kgf·m, 17 ft·lb)

- T4: 25 N·m (2.5 kgf·m, 18 ft·lb)
- T5: 10 N·m (1.0 kgf·m, 89 in·lb)
- T6: 8.0 N·m (0.80 kgf·m, 71 in·lb)
- EO: Apply engine oil.
- G: Apply grease.
- L: Apply a non-permanent locking agent.
- MO: Apply molybdenum disulfide oil solution.
- SS: Apply silicone sealant.

Specifications

Item	Standard
<p>Coolant Provided when Shipping</p> <p>Type</p> <p>Color</p> <p>Mixed Ratio</p> <p>Freezing Point</p> <p>Total Amount</p>	<p>Permanent type of antifreeze (soft water and ethylene glycol plus corrosion and rust inhibitor chemicals for aluminum engines and radiators)</p> <p>Green</p> <p>Soft water 50%, Coolant 50%</p> <p>-35°C (-31°F)</p> <p>3.6 L (3.8 US qt) (reserve tank full level including radiator and engine)</p>
<p>Radiator Cap</p> <p>Relief Pressure</p>	<p>93 ~ 123 kPa (0.95 ~ 1.25 kgf/cm², 14 ~ 18 psi)</p>
<p>Thermostat</p> <p>Valve Opening Temperature</p> <p>Valve Full Opening Lift</p>	<p>58 ~ 62°C (136 ~ 144°F)</p> <p>8 mm (0.31 in.) or more @75°C (167°F)</p>

Special Tools - Bearing Driver: 57001-382

Bearing Driver Set: 57001-1129

Sealant - Kawasaki Bond (Silicone Sealant): 56019-120

4-4 COOLING SYSTEM

Coolant Flow Chart

Permanent type antifreeze is used as a coolant to protect the cooling system from rust and corrosion. When the engine starts, the water pump turns and the coolant circulates.

The thermostat is a wax pellet type which opens or closes with coolant temperature changes. The thermostat continuously changes its valve opening to keep the coolant temperature at the proper level. When coolant temperature is 55°C (131°F) or more, the thermostat closes so that the coolant flow is restricted through the air bleeder hole, causing the engine to warm up more quickly. When coolant temperature is more than 58 ~ 62°C (136 ~ 144°F), the thermostat opens and the coolant flows.

When the coolant temperature goes up beyond 95 ~ 101°C (203 ~ 214°F), the radiator fan switch conducts to operate the radiator fan. The radiator fan draws air through the radiator core when there is not sufficient air flow such as at low speeds. This increases up the cooling action of the radiator. When the coolant temperature goes down from the operation temperature by 3 ~ 8°C (37 ~ 46°F), the fan switch opens and the radiator fan stops.

In this way, this system controls the engine temperature within narrow limits where the engine operates most efficiently even if the engine load varies.

The system is pressurized by the radiator cap to suppress boiling and the resultant air bubbles which can cause engine overheating. As the engine warms up, the coolant in the radiator and the water jacket expands. The excess coolant flows through the radiator cap and hose to the reserve tank to be stored there temporarily. Conversely, as the engine cools down, the coolant in the radiator and the water jacket contracts, and the stored coolant flows back to the radiator from the reserve tank.

The radiator cap has two valves. One is a pressure valve which holds the pressure in the system when the engine is running. When the pressure exceeds 0.95 ~ 1.25 kgf/m² (14 ~ 18 psi), the pressure valve opens and releases the pressure to the reserve tank. As soon as pressure escapes, the valve closes, and keeps the pressure at 0.95 ~ 1.25 kgf/m² (14 ~ 18 psi). When the engine cools down, another small valve (vacuum valve) in the cap opens. As the coolant cools, the coolant contracts to from a vacuum in the system. The vacuum valve opens and allows the coolant from the reserve tank to enter the radiator.

Coolant Flow Chart

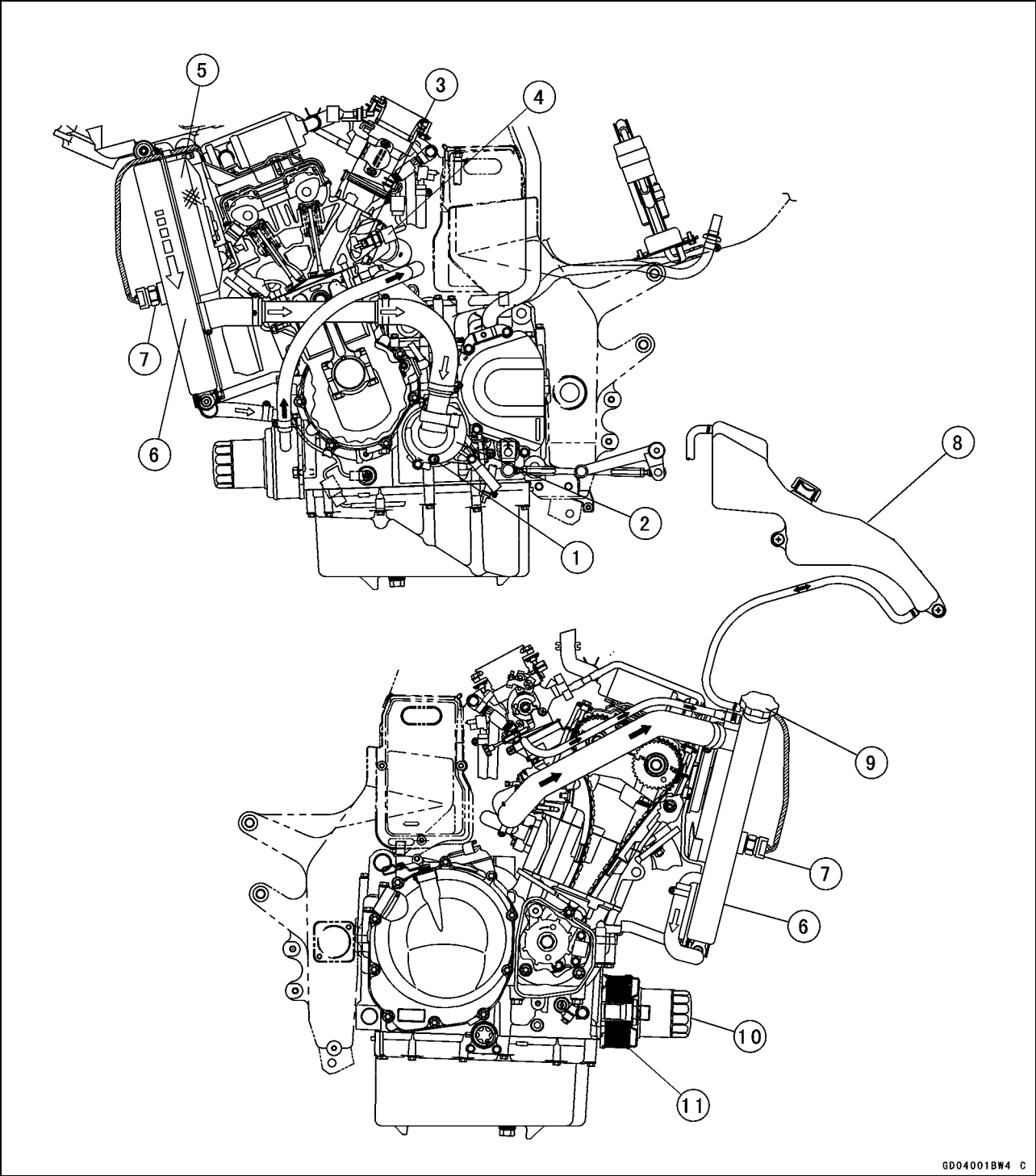

- 1. Drain Bolt
- 2. Water Pump
- 3. Thermostat
- 4. Water Temperature Sensor
- 5. Radiator Fan
- 6. Radiator

- 7. Radiator Fan Switch
- 8. Reservoir Tank
- 9. Radiator Cap
- 10. Oil Filter
- 11. Oil Cooler

4-6 COOLING SYSTEM

Coolant

Coolant Deterioration Inspection

- Visually inspect the coolant in the reserve tank.
- ★ If whitish cotton-like wafts are observed, aluminum parts in the cooling system are corroded. In either case, flush the cooling system.
- ★ If the coolant gives off an abnormal smell, check for a cooling system leak. It may be caused by exhaust gas leaking into the cooling system.

Coolant Level Inspection

NOTE

○ Check the level when the engine is cold (room or ambient temperature).

- Check the coolant level in the reserve tank with the motorcycle held perpendicular. The coolant level should be between the “F” (full) [A] level and the “L” (low) [B] level.
- ★ If the coolant level is lower than the low level line, add coolant to the full level line.



CAUTION

For refilling, add the specified mixture of coolant and soft water. Adding water alone dilutes the coolant and degrades its anticorrosion properties. The diluted coolant can attack the aluminum engine parts. In an emergency, soft water alone can be added, but the diluted coolant must be returned to the correct mixture ratio within a few days. If coolant must be added often, or the reservoir tank has run completely dry, there is probably leakage in the cooling system. Check the system for leaks.

Coolant Draining

- Refer to the Coolant Change in the Periodic Maintenance chapter.

Coolant Filling

- Refer to the Coolant Change in the Periodic Maintenance chapter.

Coolant

Pressure Testing

- Remove:
 - Right Lower Inner Cover (see Frame chapter)
 - Right Air Inlet Duct (see Fuel System (DFI) chapter)
- Remove the radiator cap, and install a cooling system pressure tester [A] on the filler neck.

NOTE

○ *Wet the cap sealing surfaces with water or coolant to prevent pressure leaks.*

- Build up pressure in the system carefully until the pressure reaches 123 kPa (1.25 kgf/cm², 18 psi).

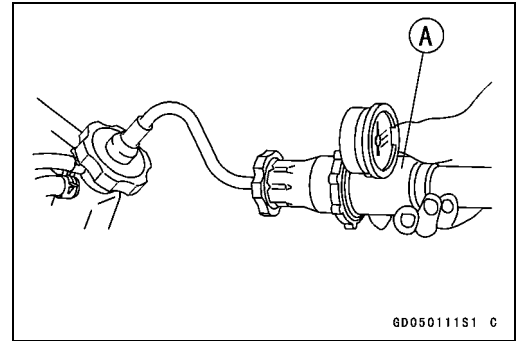

CAUTION

During pressure testing, do not exceed the pressure for which the system is designed. The maximum pressure is 123 kPa (1.25 kgf/cm², 18 psi).

- Watch the gauge for at least 6 seconds.
- ★ If the pressure holds steady, the system is all right.
- ★ If the pressure drops and no external source is found, check for internal leaks. Droplets in the engine oil indicate internal leakage. Check the cylinder head gasket and the water pump.
- Remove the pressure tester, replenish the coolant, and install the radiator cap.

Cooling System Flushing

Over a period of time, the cooling system accumulates rust, scale, and lime in the water jacket and radiator. When this accumulation is suspected or observed, flush the cooling system. If this accumulation is not removed, it will clog up the water passage and considerably reduce the efficiency of the cooling system.

- Drain the cooling system (see Coolant Change in the Periodic Maintenance chapter).
- Fill the cooling system with fresh water mixed with a flushing compound.

CAUTION

Do not use a flushing compound which is harmful to the aluminum engine and radiator. Carefully follow the instructions supplied by the manufacturer of the cleaning product.

- Warm up the engine, and run it at normal operating temperature for about ten minutes.
- Stop the engine, and drain the cooling system.
- Fill the system with fresh water.
- Warm up the engine and drain the system.
- Repeat the previous two steps once more.
- Fill the system with a permanent type coolant and bleed the air from the system (see Coolant Change in the Periodic Maintenance chapter).

4-8 COOLING SYSTEM

Water Pump

Water Pump Removal

- Drain the coolant (see Coolant Change in the Periodic Maintenance chapter).
- Remove:
 - Left Lower Fairing (see Frame chapter)
 - Cooling Pipe Bolt [A]
 - Cooling Hose with Pipe [B]
- Loosen the hose clamp [C] and pull out the cooling hose [D].

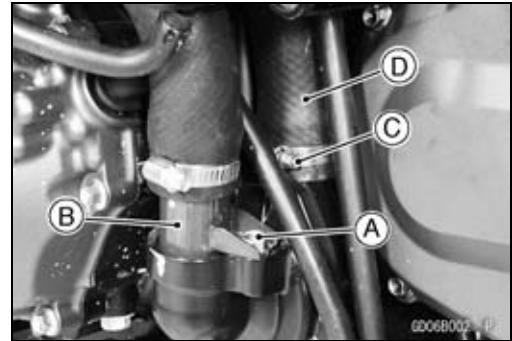

- Remove:
 - Water Pump Bolts [A]
 - Water Pump Bolt with the Clamp [B]

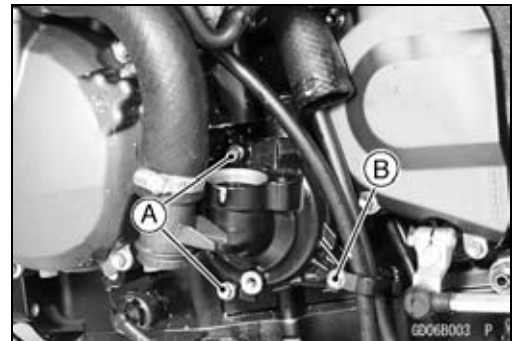

- Remove the water pump cover [A] by inserting the screw driver to the pry point [B] on the water pump housing [C].
- When the water pump cover is removed, hold the water pump housing to the crank case side.

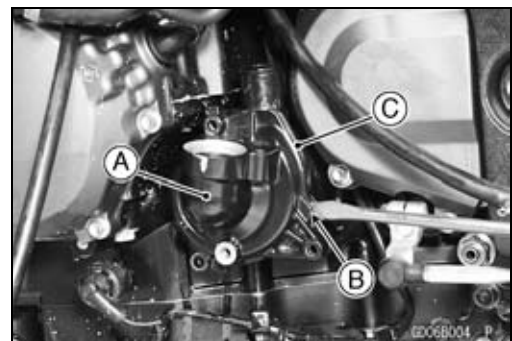

- Shift the transmission into 1st gear position.
- Unscrew the bolt [A] and remove the impeller [B] to hold the water pump housing [C].

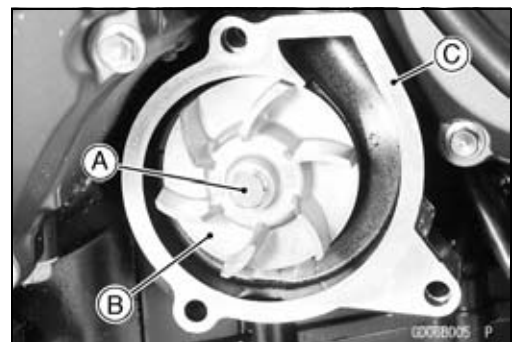

- Remove the water pump housing [B] to hold the water (oil) pump shaft [A] to the crankcase side.

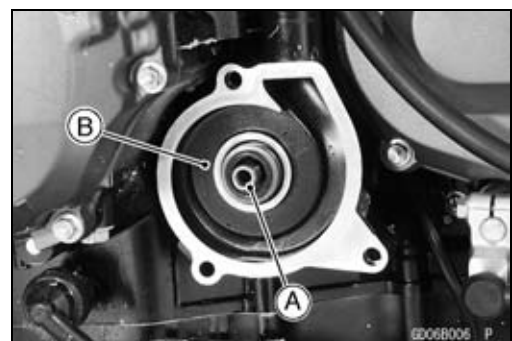

Water Pump

Water Pump Installation

- Check to see that the knock pins [A].
- Water pump housing [B] are in place to apply engine oil at O-ring.
- Apply molybdenum disulfide oil solution to the water (oil) pump shaft [C] to the journal portion (about 10 mm (0.4 in.) [D]) of the water pump housing.
- Install the water pump housing.

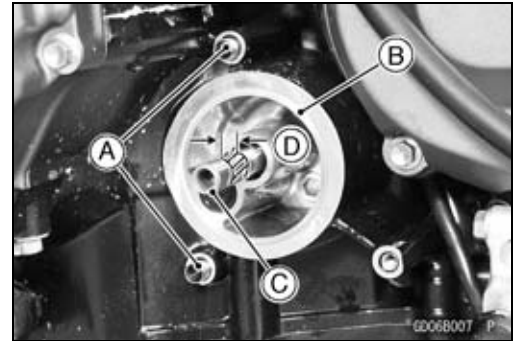

- Clean the sliding surfaces [A] of the mechanical seal and impeller with a high flash-point solvent.
- Apply little coolant to the sliding surfaces.
- Check to see that the knock pins [B] is in place.
- Shift the transmission into 1st gear position.
- Install:
 - Impeller
 - Bolt

Torque - Water Pump Impeller Bolt: 10 N·m (1.0 kgf·m, 89 in·lb)

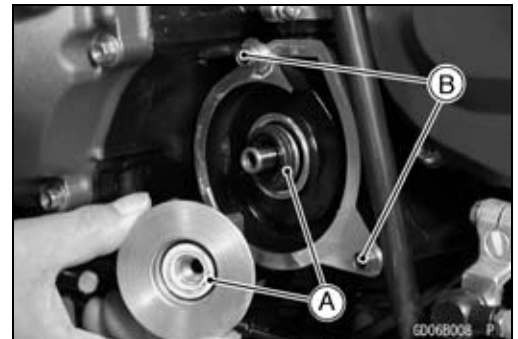

- Apply high temperature grease to the O-ring of the cooling pipe.
- Install:
 - Water Pump Cover
 - Bolts
 - Cooling Hoses

Torque - Water Pump Cover Bolts: 12 N·m (1.2 kgf·m, 106 in·lb)

Coolant Pipe Bolt: 12 N·m (1.2 kgf·m, 106 in·lb)

Water Pump Impeller Disassembly/Assembly

- The sealing seat and rubber seal may be removed easily by hand.
- Apply coolant around the surfaces of the rubber seal and sealing seat.
- Install the rubber seal [A] and sealing seat [B] into the impeller by pressing them by hand until the seat stops at the bottom of the hole.
- Tighten the water pump impeller bolt by special torque.

Torque - Water Pump Impeller Bolt: 10 N·m (1.0 kgf·m, 89 in·lb)

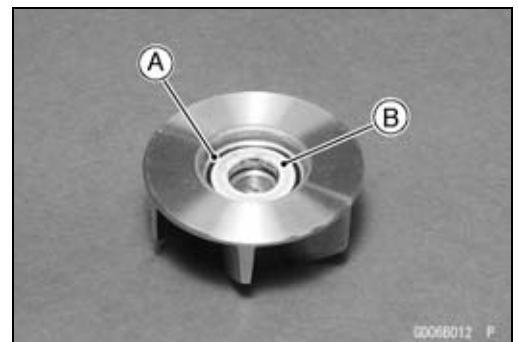

Water Pump Inspection

- Check the drainage outlet passage [A] at the bottom of the water pump body for coolant leaks.
- ★ If the mechanical seal is damaged, the coolant leaks through the seal and drains through the passage. Replace the mechanical seal unit.



4-10 COOLING SYSTEM

Water Pump

Water Pump Impeller Inspection

- Visually inspect the impeller [A].
- ★ If the surface is corroded, or if the blades [B] are damaged, replace the impeller.

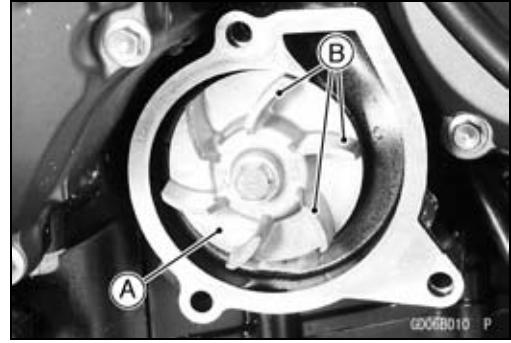

Water Pump Housing Disassembly

CAUTION

Do not damage the hole wall of the water pump housing.

- Insert a bar [A] into the pump housing [B], and hammer evenly around the circumference of the mechanical seal bottom [C].
- Take the oil seal [A] out of the housing [B] with a hook [C].

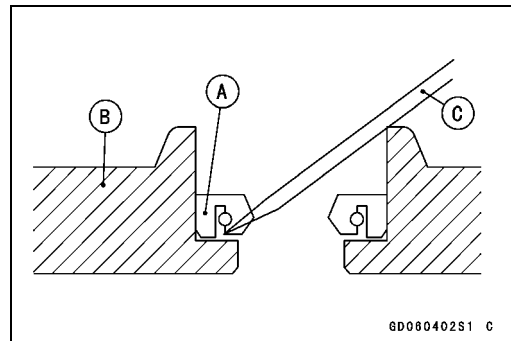
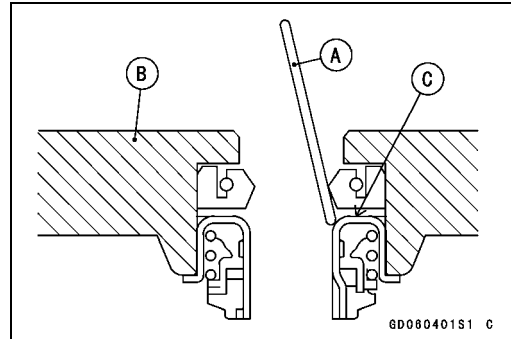

Water Pump Housing Assembly

CAUTION

Do not reuse the mechanical seal and oil seal.

- Apply high temperature grease to the oil seal lips [A].
- Press the new oil seal into the housing with a bearing driver [B] until it stops at the bottom surface [C] of the housing.

Special Tool - Bearing Driver Set: 57001-1129

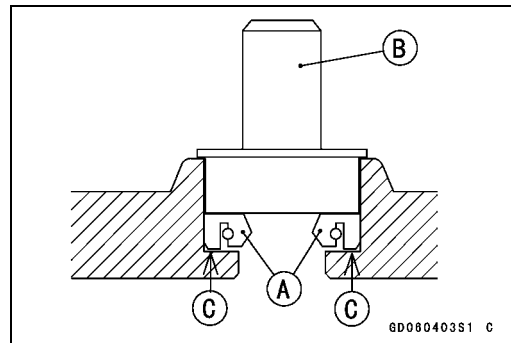

CAUTION

Be careful not to damage the sealing surface of the mechanical seal.

- Press the new mechanical seal into the housing with stem bearing driver [A] until its flange [B] touches the surface [C] of the housing.

Special Tool - Bearing Driver: 57001-382

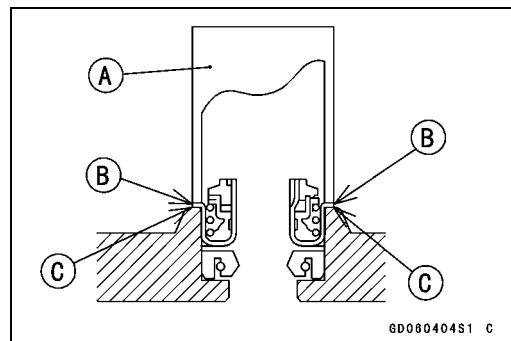

Water Pump

Mechanical Seal Inspection

- Visually inspect the mechanical seal.
- ★ If any one of the parts is damaged, replace the mechanical seal as a unit.
 - Impeller Sealing Seat Surface [A]
 - Rubber Seal [B]
 - Mechanical Seal [C]

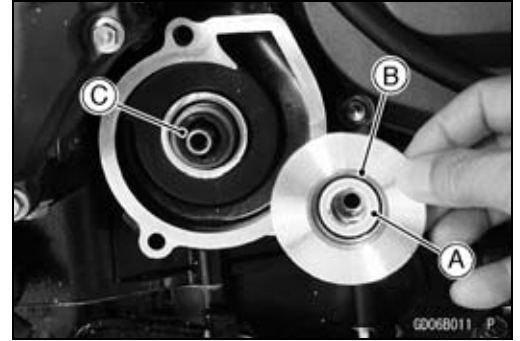

4-12 COOLING SYSTEM

Radiator, Radiator Fan

Radiator and Radiator Fan Removal

⚠ WARNING

The radiator fan is connected directly to the battery. The radiator fan may start even if the ignition switch is off. **NEVER TOUCH THE RADIATOR FAN UNTIL THE RADIATOR FAN CONNECTOR IS DISCONNECTED. TOUCHING THE FAN BEFORE THE CONNECTOR IS DISCONNECTED COULD CAUSE INJURY FROM THE FAN BLADES.**

- Remove:
 - Lower Inner Covers (see Frame chapter)
 - Air Inlet Ducts [A] (see Fuel System (DFI) chapter)
 - Radiator Fan Connectors [B]
 - Lower Fairings [C] with Lower Inner Fairing (see Frame chapter)
 - Coolant (drain, see Coolant Change in the Periodic Maintenance chapter)
 - Fan Switch Lead Connector [A]

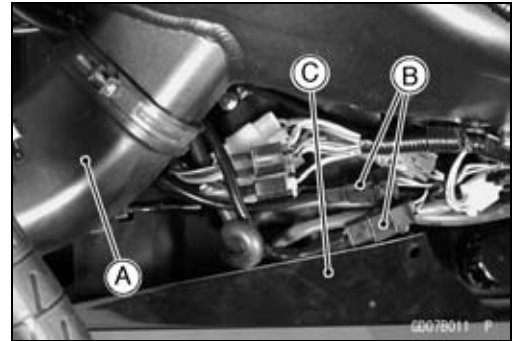

- Radiator Mounting Bracket Bolts [A]
- Left Horn Bolt [B]
- Left Horn [C]
- Radiator Cooling Hose Clamp Bolts (loosen) [D]
- Radiator Cooling Hoses [E]
- Clamp [F]

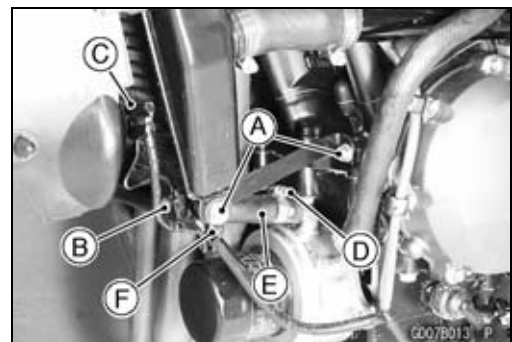

- Right Horn Bolt [A]
- Right Horn [B]
- Open the clamps [C] and remove the horn harness [D].

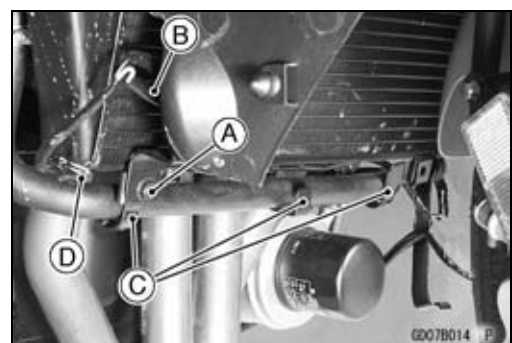

Radiator, Radiator Fan

- Remove:
 - Reserve Tank Hose [A]
 - Bypass Hose [B]
 - Radiator Cooling Hose Clamp Bolt (loosen) [C]
 - Radiator Cooling Hose [D]
 - Rivet Screw [E]
 - Radiator Mounting Bolts with Clamps
 - Radiator [F]

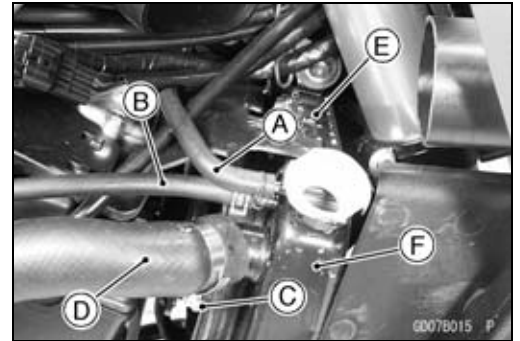

- Remove:
 - Radiator Fan Mounting Bolts [A]
 - Radiator Fans [B]

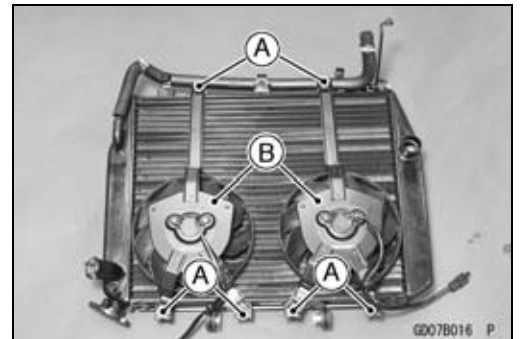

CAUTION

Do not touch the radiator core. This could damage the radiator fins, resulting in loss of cooling efficiency.

Radiator and Radiator Fan Installation

- Installation is the reverse of removal.
- Install the radiator bracket collars [A] as shown.
 - Rubber Damper [B]
 - Radiator [C]
 - Stay [D]
 - Clamp [E]
- Install the cooling hoses and horn harness in accordance with the Wire and Hose Routing section in the General Information chapter.

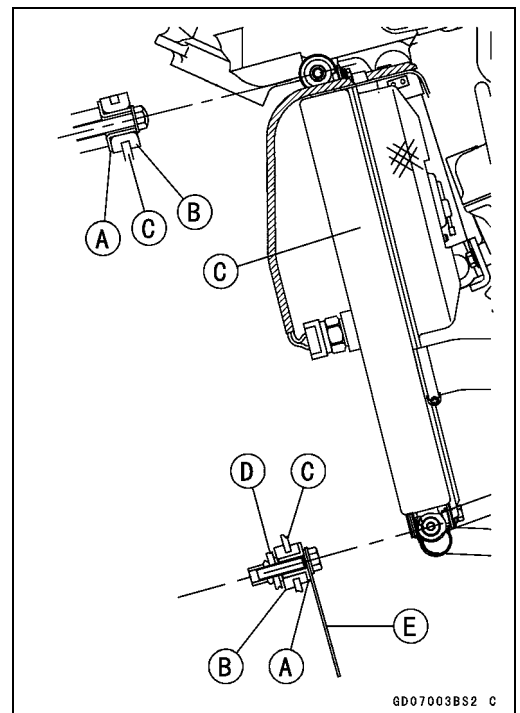

Radiator Inspection

- Check the radiator core.
 - ★ If there are obstructions to air flow, remove them.
 - ★ If the corrugated fins [A] are deformed, carefully straighten them.
 - ★ If the air passages of the radiator core are blocked more than 20% by unremovable obstructions or irreparably deformed fins, replace the radiator with a new one.

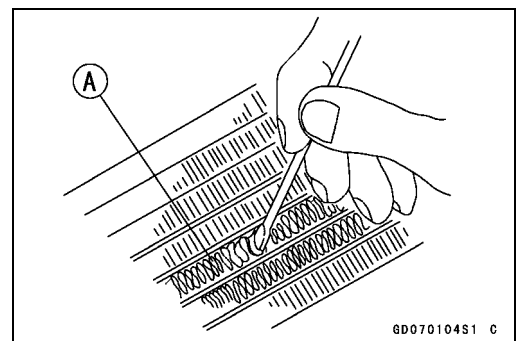

4-14 COOLING SYSTEM

Radiator, Radiator Fan

CAUTION

When cleaning the radiator with steam cleaner, be careful of the following to prevent radiator damage. Keep the steam gun [A] away more than 0.5 m (1.6 ft) [B] from the radiator core. Hold the steam gun perpendicular to the core surface. Run the steam gun following the core fin direction.

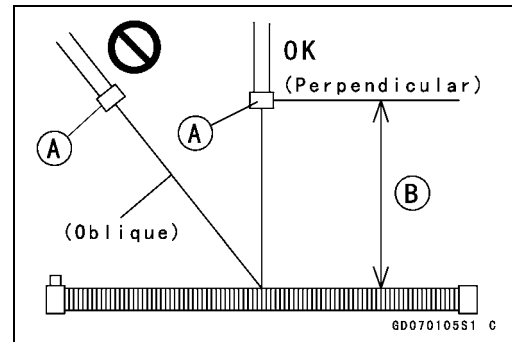

Radiator Cap Inspection

- Check the condition of the top [B] and bottom [A] valve seals and valve spring [C].
- ★ If any one of them shows visible damage, replace the cap with a new one.

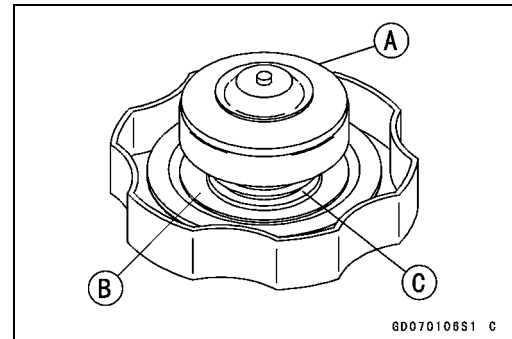

- Install the cap [A] on a cooling system pressure tester [B].

NOTE

○ Wet the cap sealing surfaces with water or coolant to prevent pressure leaks.

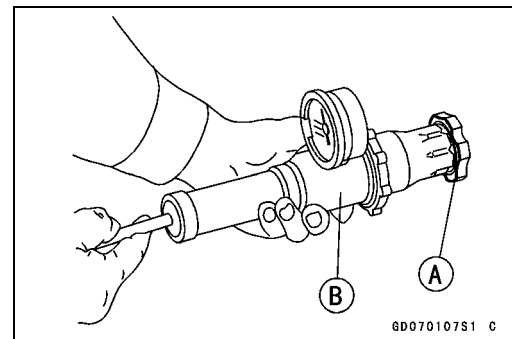

- Watching the pressure gauge, pump the pressure tester to build up the pressure until the relief valve opens: the gauge hand flicks downward. Stop pumping and measure leak time at once. The relief valve must open within the specified range in the table below and the gauge hand must remain within the same range at least 6 seconds.

Radiator Cap Relief Pressure

Standard: 93 ~ 123 kPa (0.95 ~ 1.25 kgf/cm², 14 ~ 18 psi)

- ★ If the cap cannot hold the specified pressure, or if it holds too much pressure, replace it with a new one.

Thermostat

Thermostat Removal

- Drain:
Coolant (Cylinder) (see Coolant Change in the Periodic Maintenance chapter)
- Remove:
Lower Fairings (see Frame chapter)
Fuel Hose (see Fuel System (DFI) chapter)
Water Temperature Sensor Connector
Cooling Hoses
Starter Motor Cable
Fitting Bolts [A]
Cooling Hose Fitting [B]
- Remove:
Thermostat Housing Cover Bolts [A]
Thermostat Housing Cover [B]
Thermostat

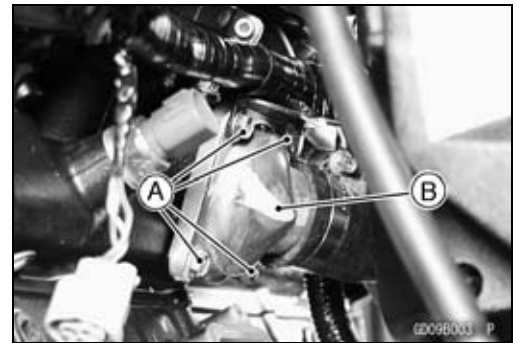
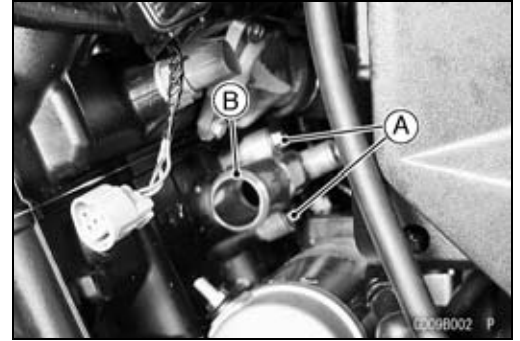

Thermostat Installation

- Install the thermostat [A] in the housing so that the air bleeder hole [B] is on top.
- Be sure to install the coolant-applied O-rings on the housing cover and fitting.
- Tighten the housing cover and fitting bolts.
- Apply a non-permanent locking agent to the thermostat housing cover bolts.

Torque - Fitting Bolts: 12 N·m (1.2 kgf·m, 106 in·lb)

Thermostat Housing Cover Bolts: 8.0 N·m (0.80 kgf·m, 71 in·lb)

- Fill the radiator with coolant (see Coolant Change in the Periodic Maintenance chapter).

Thermostat Inspection

- Remove the thermostat, and inspect the thermostat valve [A] at room temperature.
- ★ If the valve is open, replace the thermostat with a new one.

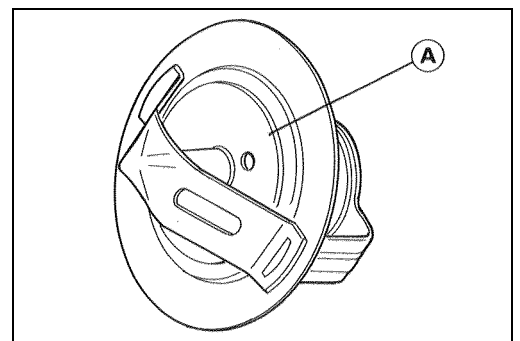
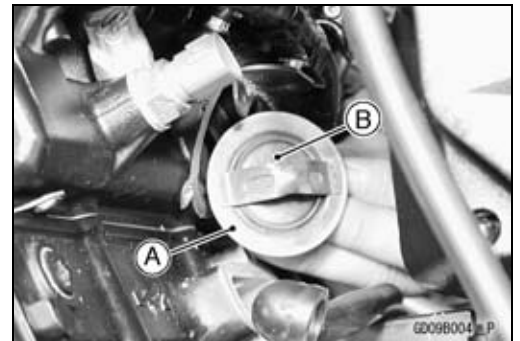

4-16 COOLING SYSTEM

Thermostat

- To check valve opening temperature, suspend the thermostat [A] in a container of water and raise the temperature of the water.
- The thermostat must be completely submerged and must not touch the container sides or bottom. Suspend an accurate thermometer [B] in the water. It must not touch the container, either.
- ★ If the measurement is out of the specified range, replace the thermostat with a new one.

Thermostat Valve Opening Temperature

Standard: 58 ~ 62°C (136 ~ 144°F)

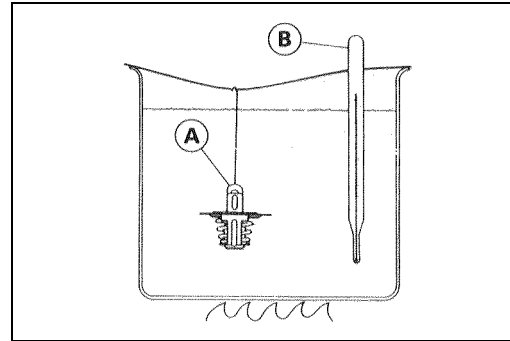

Hose and Pipes

Hose Installation

- Install the hoses and pipes being careful to follow bending direction or diameter. Avoid sharp bending, kinking, flattening, or twisting.
- Install the clamps [A] as near as possible to the hose end to clear the raised rib or the fitting. This will prevent the hoses from working loose.
- The clamp screws should be positioned correctly to prevent the clamps from contacting anything.

Torque - Coolant Hose Clamp Screws: 2.0 N·m (0.20 kgf·m, 18 in·lb)

Hose Inspection

- Refer to the Coolant Hose and Connection Inspection in the Periodic Maintenance chapter.

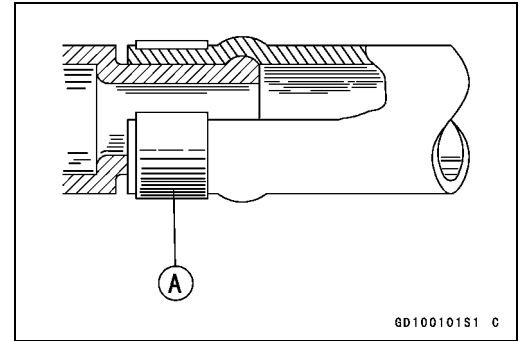

4-18 COOLING SYSTEM

Radiator Fan Switch, Water Temperature Sensor

Radiator Fan Switch, Water Temperature Sensor Removal

CAUTION
<p>The fan switch or the water temperature sensor should never be allowed to fall on a hard surface. Such a shock to their parts can damage them.</p>

- Drain the coolant (see Coolant Change in the Periodic Maintenance chapter).
- Remove:
 - Left Lower Inner Cover (see Frame chapter)
 - Radiator Fan Switch Lead Connectors [A]
 - Radiator Fan Switch [B]
- Refer to the Fuel System (DFI) chapter for the Water Temperature Sensor Removal/Installation.

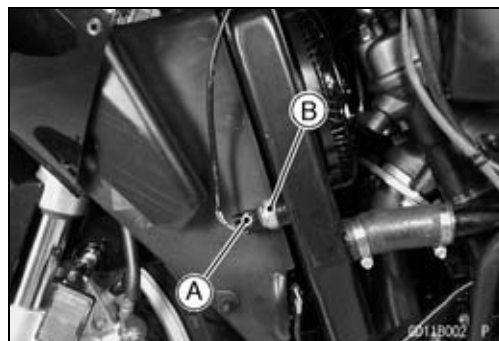

Radiator Fan Switch, Water Temperature Sensor Installation

- Apply silicone sealant to the threads of the water temperature sensor.
 - Sealant - Kawasaki Bond (Silicone Sealant): 56019-120**
- Tighten the fan switch and water temperature sensor.
 - Torque - Radiator Fan Switch: 18 N·m (1.8 kgf·m, 13 ft·lb)**
 - Water Temperature Sensor: 25 N·m (2.5 kgf·m, 18 ft·lb)**
- Fill the coolant and bleed the air from cooling system (see Coolant Change in the Periodic Maintenance chapter).

Radiator Fan Switch, Water Temperature Sensor Inspection

- Refer to the Electrical System chapter for the Radiator Fan Switch Inspection.
- Refer to the Fuel System (DFI) chapter for the Water Temperature Sensor Inspection.

Engine Top End

Table of Contents

Exploded View.....	5-2	Cylinder Head.....	5-18
Specifications	5-5	Cylinder Compression	
Clean Air System.....	5-8	Measurement	5-18
Air Suction Valve Removal.....	5-8	Cylinder Head Removal	5-19
Air Suction Valve Installation.....	5-8	Cylinder Head Installation	5-20
Air Suction Valve Check.....	5-8	Cylinder Head Warp.....	5-21
Vacuum Switch Valve Removal		Valves	5-22
(ZX1200-B1/B2)	5-9	Valve Clearance Check.....	5-22
Vacuum Switch Valve Installation		Valve Removal	5-22
(ZX1200-B1/B2)	5-9	Valve Installation	5-22
Vacuum Switch Valve Test		Valve Guide Removal	5-22
(ZX1200-B1/B2)	5-9	Valve Guide Installation	5-23
Air Switching Valve Removal		Valve-to-Guide Clearance	
(ZX1200-B3).....	5-10	Measurement (Wobble	
Air Switching Valve Installation		Method).....	5-23
(ZX1200-B3).....	5-10	Valve Seat Inspection	5-24
Air Switching Valve Operation		Valve Seat Repair	5-24
Test (ZX1200-B3)	5-10	Cylinder, Pistons.....	5-29
Air Switching Valve Unit Test		Cylinder Removal.....	5-29
(ZX1200-B3).....	5-10	Cylinder Installation.....	5-29
Clean Air System Hose		Piston Removal.....	5-30
Inspection.....	5-10	Piston Installation.....	5-31
Cylinder Head Cover	5-11	Cylinder Wear	5-32
Cylinder Head Cover Removal	5-11	Piston Wear	5-32
Cylinder Head Cover Installation .	5-11	Piston Ring, Piston Ring Groove	
Camshaft Chain Tensioner	5-13	Wear.....	5-32
Camshaft Chain Tensioner		Piston Ring Groove Width.....	5-32
Removal.....	5-13	Piston Ring Thickness	5-33
Camshaft Chain Tensioner		Piston Ring End Gap	5-33
Installation	5-13	Throttle Body Holder.....	5-34
Camshaft, Camshaft Chain	5-14	Throttle Body Holder Installation..	5-34
Camshaft Removal	5-14	Muffler.....	5-35
Camshaft Installation	5-14	Muffler Removal.....	5-35
Camshaft, Camshaft Cap Wear ...	5-16	Muffler Installation.....	5-35
Camshaft Runout.....	5-17	Muffler Body Removal.....	5-35
Cam Wear.....	5-17	Muffler Body Installation.....	5-36
Camshaft Chain Removal.....	5-17		

5-2 ENGINE TOP END

Exploded View

ZX1200-B1/B2

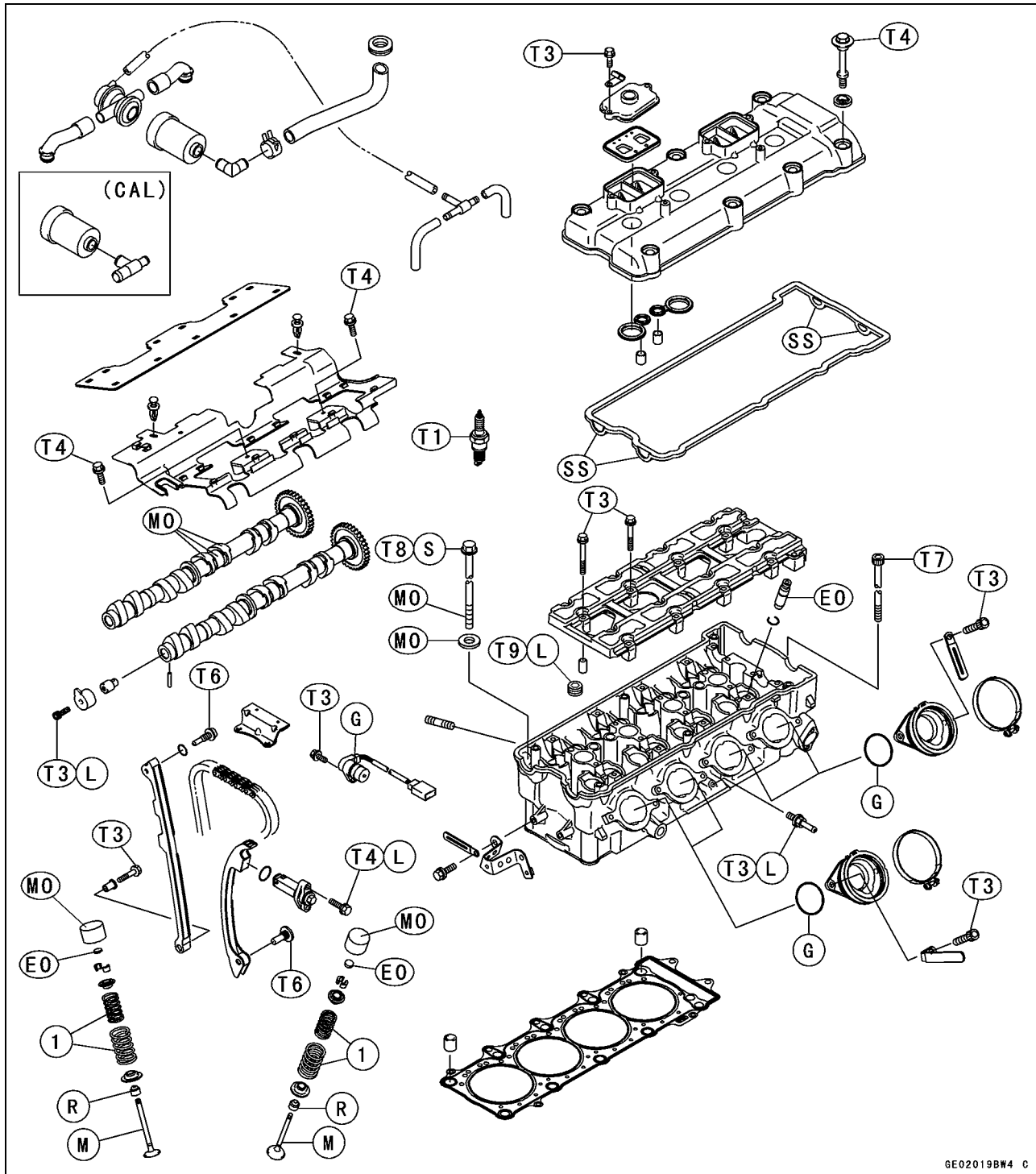

GE02019BW4 C

1. Closed coil end faces downward.
- T1: 13 N·m (1.3 kgf·m, 115 in·lb)
 - T2: 34 N·m (3.5 kgf·m, 25 ft·lb)
 - T3: 12 N·m (1.2 kgf·m, 106 in·lb)
 - T4: 10 N·m (1.0 kgf·m, 89 in·lb)
 - T5: 15 N·m (1.5 kgf·m, 11 ft·lb)
 - T6: 25 N·m (2.5 kgf·m, 18 ft·lb)
 - T7: 20 N·m (2.0 kgf·m, 15 ft·lb)
 - T8: 59 N·m (6.0 kgf·m, 44 ft·lb)
 - T9: 22 N·m (2.2 kgf·m, 16 ft·lb)

- EO: Apply engine oil.
- G: Apply grease.
- L: Apply a non-permanent locking agent.
- M: Apply molybdenum disulfide grease.
- MO: Apply molybdenum disulfide oil solution.
- R: Replacement Parts
- S: Follow the specific tightening sequence.
- SS: Apply silicone sealant.
- CAL: California Model only

Exploded View

ZX1200-B3

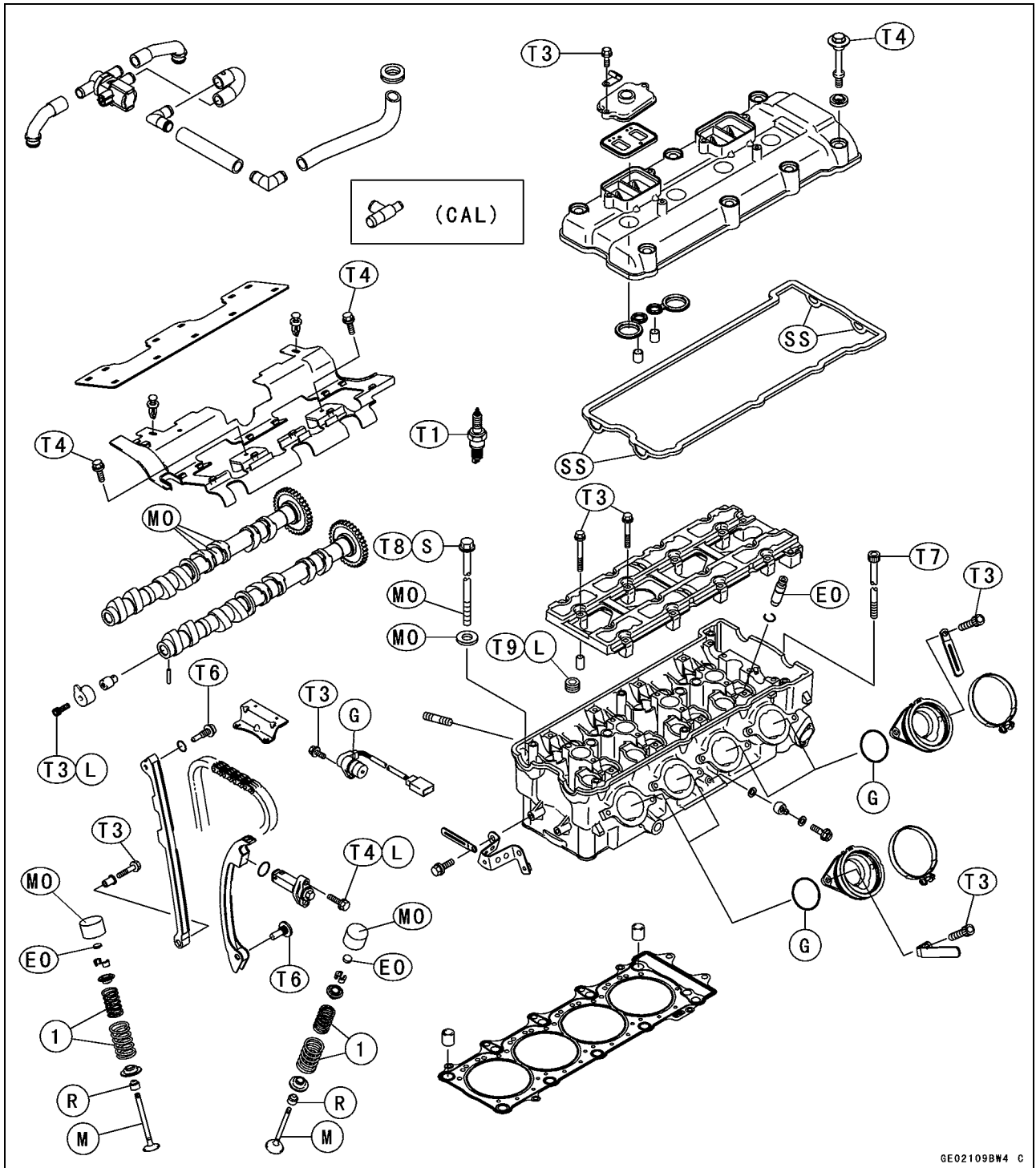

GE02109BW4 C

- 1. Closed coil end faces downward.
- T1: 13 N·m (1.3 kgf·m, 115 in·lb)
- T2: 34 N·m (3.5 kgf·m, 25 ft·lb)
- T3: 12 N·m (1.2 kgf·m, 106 in·lb)
- T4: 10 N·m (1.0 kgf·m, 89 in·lb)
- T5: 15 N·m (1.5 kgf·m, 11 ft·lb)
- T6: 25 N·m (2.5 kgf·m, 18 ft·lb)
- T7: 20 N·m (2.0 kgf·m, 15 ft·lb)
- T8: 59 N·m (6.0 kgf·m, 44 ft·lb)
- T9: 22 N·m (2.2 kgf·m, 16 ft·lb)

- EO: Apply engine oil.
- G: Apply grease.
- L: Apply a non-permanent locking agent.
- M: Apply molybdenum disulfide grease.
- MO: Apply molybdenum disulfide oil solution.
- R: Replacement Parts
- S: Follow the specific tightening sequence.
- SS: Apply silicone sealant.
- CAL: California Model only

5-4 ENGINE TOP END

Exploded View

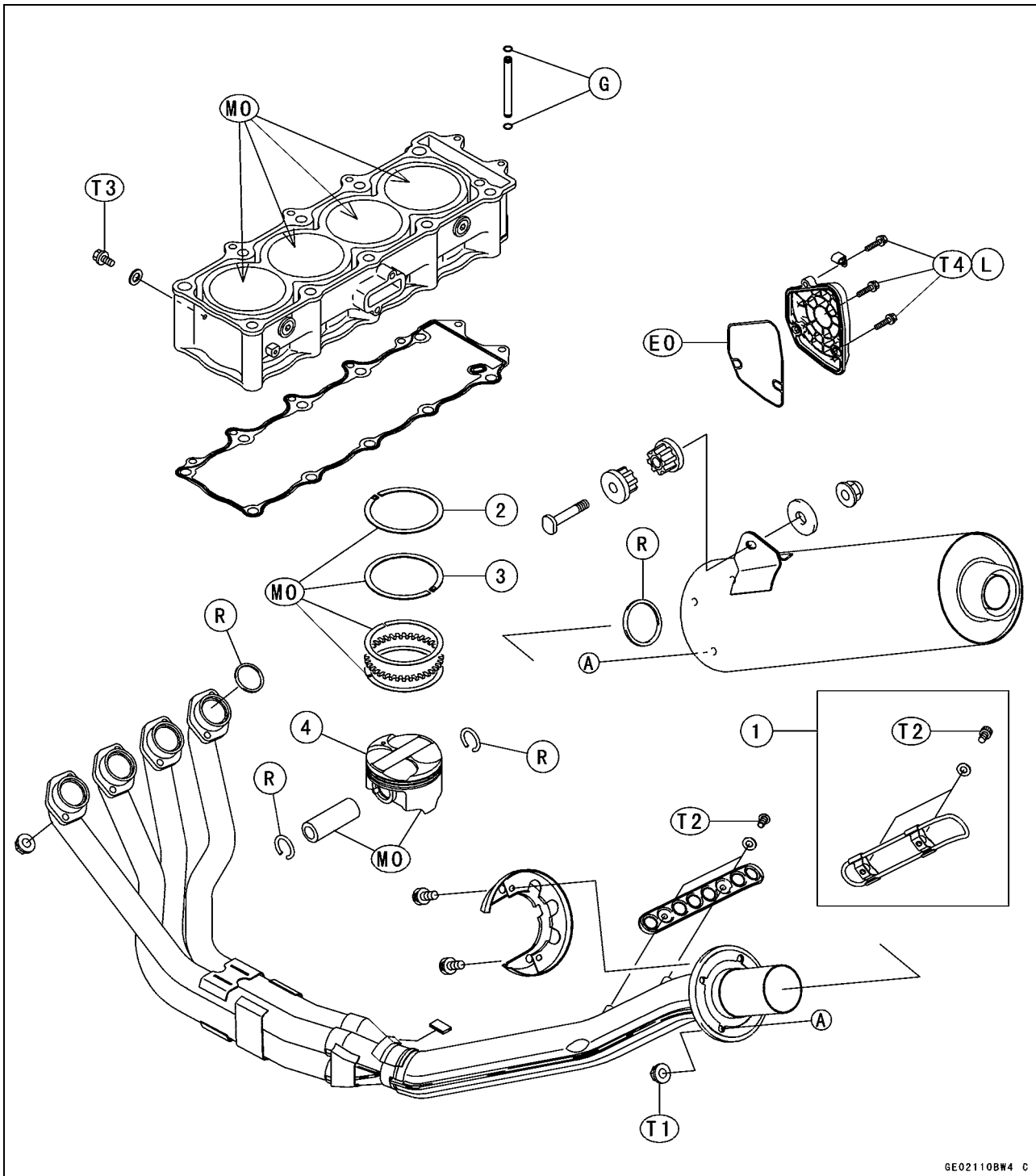

GE02110BW4 C

- 1. Muffler Cover (ZX1200-B1/B2)
- 2. R marked side face up.
- 3. RN marked side face up.
- 4. A marking hollow facing forward.
- T1: 34 N·m (3.5 kgf·m, 25 ft·lb)
- T2: 12 N·m (1.2 kgf·m, 106 in·lb)
- T3: 10 N·m (1.0 kgf·m, 89 in·lb)

- T4: 15 N·m (1.5 kgf·m, 11 ft·lb)
- EO: Apply engine oil.
- G: Apply grease.
- L: Apply a non-permanent locking agent.
- MO: Apply molybdenum disulfide grease.
- R: Replacement Parts

Specifications

Item	Standard	Service Limit
Clean Air System (ZX1200-B1/B2) Vacuum Switch Valve Closing Pressure	Open → Close 41 ~ 49 kPa (310 ~ 370 mmHg)	- - -
Camshafts Cam Height: Exhaust Inlet Camshaft Journal, Camshaft Cap Clearance Camshaft Journal Diameter Camshaft Bearing Inside Diameter Camshaft Runout	36.643 ~ 36.757 mm (1.4426 ~ 1.4471 in.) 37.043 ~ 37.157 mm (1.4584 ~ 1.4629 in.) 0.028 ~ 0.071 mm (0.0011 ~ 0.0028 in.) 23.950 ~ 23.972 mm (0.9429 ~ 0.9438 in.) 24.000 ~ 24.021 mm (0.9449 ~ 0.9457 in.) TIR 0.02 mm (0.0008 in.) or less	36.54 mm (1.439 in.) 36.94 mm (1.454 in.) 0.16 mm (0.006 in.) 23.92 mm (0.942 in.) 24.08 mm (0.948 in.) TIR 0.1 mm (0.004 in.)
Cylinder Head Cylinder Compression Cylinder Head Warp	(usable range) 1 029 ~ 1 568 kPa (10.5 ~ 16 kgf/cm ² , 149 ~ 228 psi) @300 r/min (rpm) - - -	- - - 0.05 mm (0.002 in.)
Valves Valve Clearance: Exhaust Inlet Valve Head Thickness: Exhaust Inlet Valve Stem Bend Valve Stem Diameter: Exhaust Inlet	0.22 ~ 0.31 mm (0.0087 ~ 0.012 in.) 0.15 ~ 0.24 mm (0.0059 ~ 0.0094 in.) 0.8 mm (0.03 in.) 0.5 mm (0.02 in.) TIR 0.01 mm (0.0004 in.) or less 4.955 ~ 4.970 mm (0.1951 ~ 0.1957 in.) 4.975 ~ 4.990 mm (0.1959 ~ 0.1965 in.)	- - - - - - 0.5 mm (0.02 in.) 0.25 mm (0.0098 in.) TIR 0.05 mm (0.002 in.) 4.94 mm (0.194 in.) 4.96 mm (0.195 in.)

5-6 ENGINE TOP END

Specifications

Item	Standard	Service Limit
Valve Guide Inside Diameter:		
Exhaust	5.000 ~ 5.012 mm (0.1969 ~ 0.1973 in.)	5.07 mm (0.200 in.)
Inlet	5.000 ~ 5.012 mm (0.1969 ~ 0.1973 in.)	5.07 mm (0.200 in.)
Valve/valve Guide Clearance (wobble method):		
Exhaust	0.09 ~ 0.17 mm (0.0035 ~ 0.0067 in.)	0.35 mm (0.014 in.)
Inlet	0.03 ~ 0.11 mm (0.0012 ~ 0.0043 in.)	0.29 mm (0.011 in.)
Valve Seat Cutting Angle	45°, 32°, 60°, 55°	— — —
Valve Seat Surface:		
Width:		
Exhaust	0.8 ~ 1.2 mm (0.03 ~ 0.047 in.)	— — —
Inlet	0.5 ~ 1.0 mm (0.02 ~ 0.039 in.)	— — —
Outside Diameter:		
Exhaust	27.6 ~ 27.8 mm (1.086 ~ 1.094 in.)	— — —
Inlet	32.6 ~ 32.8 mm (1.283 ~ 1.291 in.)	— — —
Valve Spring Free Length:		
Exhaust (Inner)	38.08 mm (1.499 in.)	36.7 mm (1.44 in.)
Exhaust (Outer)	45.97 mm (1.810 in.)	44.3 mm (1.74 in.)
Inlet (Inner)	37.97 mm (1.495 in.)	36.5 mm (1.44 in.)
Inlet (Outer)	45.78 mm (1.802 in.)	44.2 mm (1.74 in.)
Cylinder, Piston		
Cylinder Inside Diameter	82.994 ~ 83.006 mm (3.2675 ~ 3.2679 in.)	83.06 mm (3.270 in.)
Piston Diameter	82.969 ~ 82.984 mm (3.2665 ~ 3.2671 in.)	82.82 mm (3.261 in.)
Piston/cylinder Clearance	0.010 ~ 0.037 mm (0.0004 ~ 0.0015 in.)	— — —
Piston ring/groove Clearance:		
Top	0.03 ~ 0.07 mm (0.0012 ~ 0.0028 in.)	0.17 mm (0.0067 in.)
Second	0.02 ~ 0.06 mm (0.0008 ~ 0.002 in.)	0.16 mm (0.0063 in.)

Specifications

Item	Standard	Service Limit
Piston Ring Groove Width:		
Top	0.92 ~ 0.94 mm (0.0362 ~ 0.0370 in.)	1.02 mm (0.0402 in.)
Second	1.01 ~ 1.03 mm (0.0398 ~ 0.0406 in.)	1.11 mm (0.0437 in.)
Piston Ring Thickness:		
Top	0.87 ~ 0.89 mm (0.0343 ~ 0.0350 in.)	0.80 mm (0.0315 in.)
Second	0.97 ~ 0.99 mm (0.0382 ~ 0.0390 in.)	0.90 mm (0.0354 in.)
Piston Ring End Gap:		
Top	0.25 ~ 0.40 mm (0.0098 ~ 0.0157 in.)	0.7 mm (0.0276 in.)
Second	0.40 ~ 0.55 mm (0.0157 ~ 0.0217 in.)	0.8 mm (0.0315 in.)

Special Tools - Compression Gauge: 57001-221

Valve Spring Compressor Assembly: 57001-241

Piston Pin Puller Assembly: 57001-910

Piston Ring Compressor Grip: 57001-1095

Valve Seat Cutter, 45° - ϕ 35: 57001-1116

Valve Seat Cutter, 32° - ϕ 30: 57001-1120

Valve Seat Cutter, 32° - ϕ 35: 57001-1121

Valve Seat Cutter, 60° - ϕ 30: 57001-1123

Valve Seat Cutter Holder Bar: 57001-1128

Valve Seat Cutter, 45° - ϕ 30: 57001-1187

Valve Spring Compressor Adapter, ϕ 22: 57001-1202

Valve Guide Arbor, ϕ 5.0: 57001-1203

Valve Guide Reamer, ϕ 5.0: 57001-1204

Valve Seat Cutter Holder, ϕ 5.0: 57001-1208

Valve Seat Cutter, 55° - ϕ 35: 57001-1247

Fork Oil Level Gauge: 57001-1290

Piston Ring Compressor Belt, ϕ 80 ~ 91: 57001-1320

Compression Gauge Adapter, M10 × 1.0: 57001-1458

Piston Base, ϕ 1.0: 57001-1459

Sealant - Kawasaki Bond (Silicone Sealant): 56019-120

5-8 ENGINE TOP END

Clean Air System

Air Suction Valve Removal

ZX1200-B1/B2

- Remove:
 - Lower Inner Covers (see Frame chapter)
 - Vacuum Switch Valve Hoses
 - Throttle Cable and Choke Cable Lower Ends (for Right Side Air Suction Valve Removal) (see Fuel System (DFI) chapter)
 - Air Suction Valve Cover Bolts [A]
 - Clamp [B]
 - Air Suction Valve Covers [C]
 - Air Suction Valve Assembly [D]

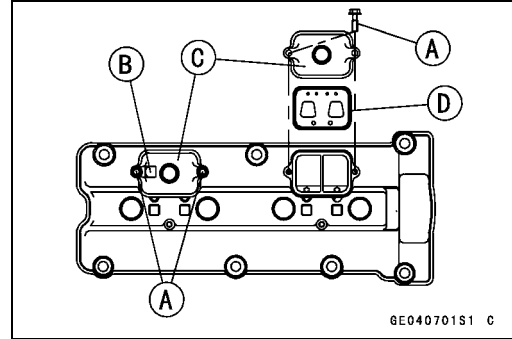

ZX1200-B3

- Remove:
 - Lower Inner Covers (see Frame chapter)
- Separate the hoses [A] from the air suction valve cover.
- Remove:
 - Air Suction Valve Cover Bolts [B]
 - Air Suction Valve Cover [C]
 - Air Suction Valve

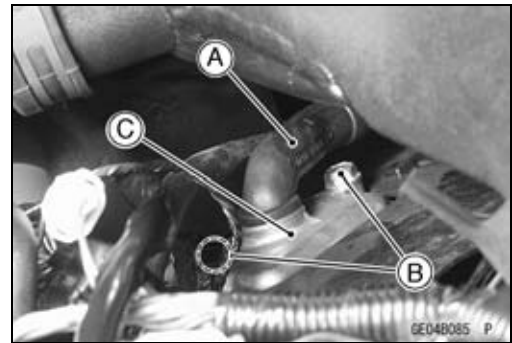

Air Suction Valve Installation

ZX1200-B1/B2

- Install the valve assembly [A] so that its reeds [B] side faces inside and its opening [C] side faces backward.
- Install the air suction valve covers.

Torque - Air Suction Valve Cover Bolts: 12 N·m (1.2 kgf·m, 106 in·lb)

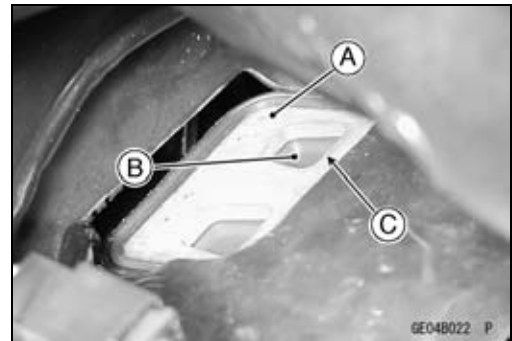

ZX1200-B3

- Install the air suction valve [A] so that its wider side [B] of the reed valve case faces the front.
- Tighten:

Torque - Air Suction Valve Cover Bolts: 12 N·m (1.2 kgf·m, 106 in·lb)



Air Suction Valve Check

- Refer to the Air Suction Valve Inspection in the Periodic Maintenance chapter.

Clean Air System

Vacuum Switch Valve Removal (ZX1200-B1/B2)

- Remove:
 - Lower Inner Covers (see Frame chapter)
- Pull off the switch valve hoses [A] and vacuum hose [B], and remove the vacuum switch valve [C].

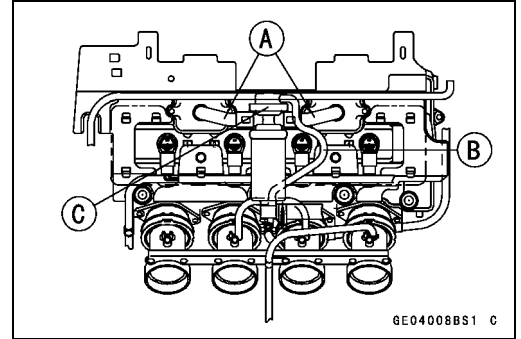

Vacuum Switch Valve Installation (ZX1200-B1/B2)

- Install the vacuum switch valve so that the air hole [A] faces downwards.
- Route the hoses correctly (see General Information chapter).

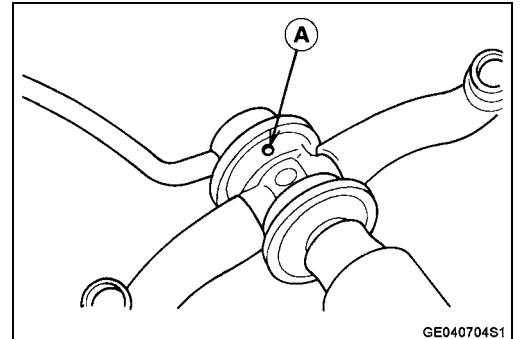

Vacuum Switch Valve Test (ZX1200-B1/B2)

- Remove:
 - Lower Inner Covers (see Frame chapter)
 - Vacuum Switch Valve (see Vacuum Switch Valve Removal)
- Connect a vacuum gauge [A] and syringe [B] or fork oil level gauge to the vacuum hoses as shown.

Special Tool - Fork Oil Level Gauge: 57001-1290
Air Flow [C]

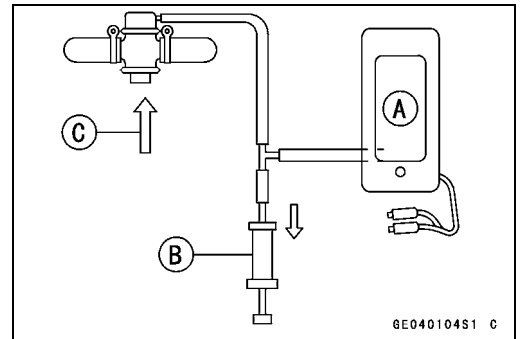

- Gradually raise the vacuum (lower the pressure) applied to the vacuum switch valve, and check the valve operation. When the vacuum is low, the vacuum switch valve should permit air to flow. When the vacuum raises to valve closing pressure, it should stop air flow.

- Spring [A]
- Diaphragm [B]
- Valve [C]
- Low Vacuum [D]
- Secondary Air Flow [E]

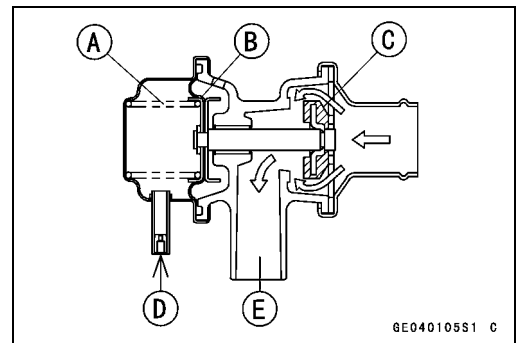

★If the vacuum switch valve does not operate as described, replace it with a new one.

NOTE

○The vacuum switch valve is checked whether there is air flow through the air cleaner hose or not.

Vacuum Switch Valve Closing Pressure (Open → Close)

Standard: 41 ~ 49 kPa (310 ~ 370 mmHg)

- High Vacuum [A]
- Secondary air cannot flow [B].

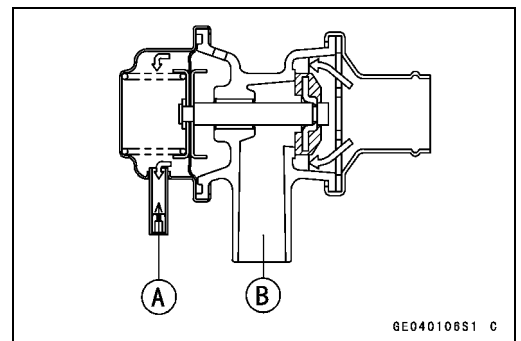

5-10 ENGINE TOP END

Clean Air System

Air Switching Valve Removal (ZX1200-B3)

- Remove:
 - Lower Inner Covers (see Frame chapter)
 - Connector [A]
 - Air Switching Valve [B]

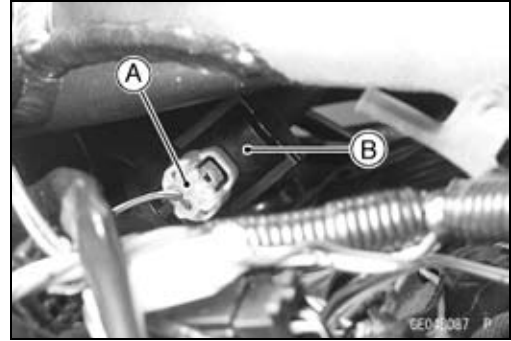

Air Switching Valve Installation (ZX1200-B3)

- Install the air switching valve so that the air duct [A] faces right side.
- Route the hose correctly (see General Information chapter).

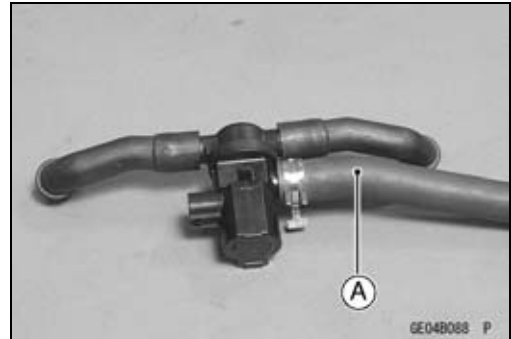

Air Switching Valve Operation Test (ZX1200-B3)

- Refer to the Air Switching Valve Operation Test in the Electrical System chapter.

Air Switching Valve Unit Test (ZX1200-B3)

- Refer to the Air Switching Valve Unit Test in the Electrical System chapter.

Clean Air System Hose Inspection

- Be certain that all the hoses are routed without being flattened or kinked, and are connected correctly to the air cleaner housing, vacuum switch valve (ZX1200-B1/B2), air switching valve (ZX1200-B3) and air suction valve covers.
- ★ If they are not, correct them. Replace them if they are damaged.

Cylinder Head Cover

Cylinder Head Cover Removal

- Remove:
 - Lower Fairings with Lower Inner Fairing (see Frame chapter)
 - Lower Inner Covers (see Frame chapter)
 - Choke Cable Lower End (see Fuel System (DFI) chapter)
 - Throttle Cable Lower Ends (see Fuel System (DFI) chapter)
 - Camshaft Position Sensor Connector
 - Switch Housing Harness Connectors
 - Starter Lockout Switch Connector
 - Ignition Switch Harness Connector with Clamp
 - Coolant Reserve Tank (see Cooling System chapter)
 - Inlet Air Pressure Sensor (see Fuel System (DFI) chapter)
 - Vacuum Switch Valve [A] (ZX1200-B1/B2) and Hoses
 - Air Switching Valve [F] (ZX1200-B3) and Hoses
 - Rubber Plate [B]
 - Stick Coils [C]
 - Baffle Plate Bolts [D]
- Remove the baffle plate [E] to the right side of the engine.

NOTE

○ If the baffle plate cannot easily be removed, remove the air suction valve covers.

- Remove the cylinder head cover bolts [A] and take off the cover [B] to the left side of the engine.

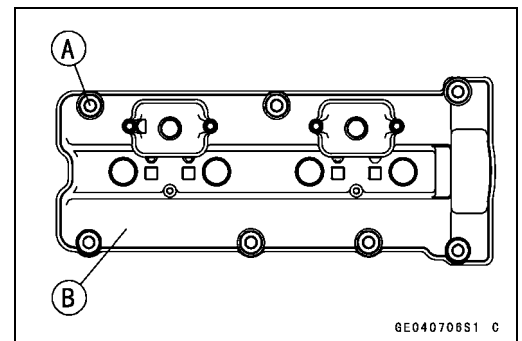
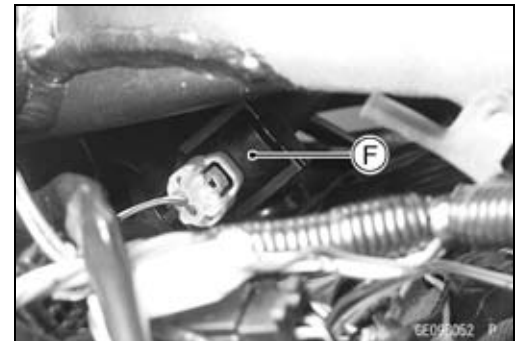
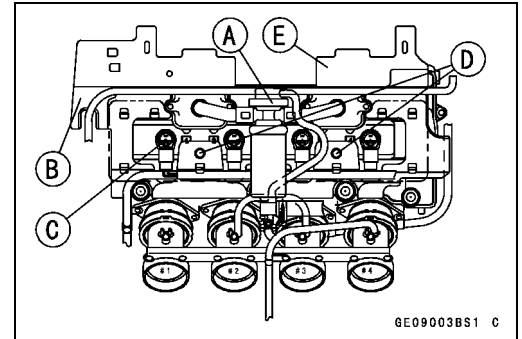

Cylinder Head Cover Installation

- Be sure to install the pins [A] and rubber gaskets [B].

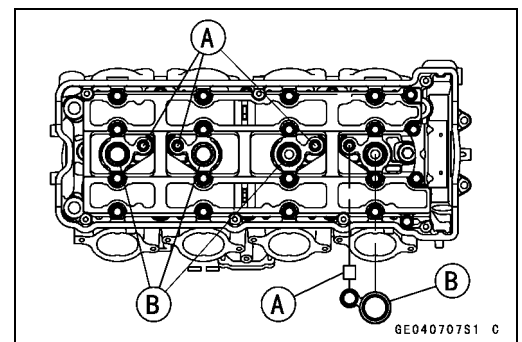

5-12 ENGINE TOP END

Cylinder Head Cover

- Replace the head cover gasket with a new one if damaged.
- Apply silicone sealant [A] to the cylinder head as shown.
Sealant - Kawasaki Bond (Silicone Sealant): 56019-120

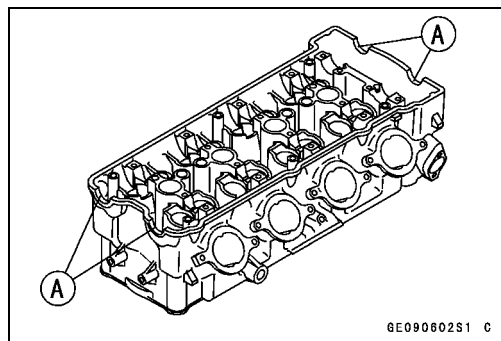

- Install the washer with the metal side [A] faces upward.
- Tighten the cover bolts following the specified tightening sequence.

Torque - Cylinder Head Cover Bolts [B]: 10 N·m (1.0 kgf·m, 89 in·lb)

Baffle Plate Bolts: 10 N·m (1.0 kgf·m, 89 in·lb)

- Route the harnesses and hoses correctly (see General Information chapter).

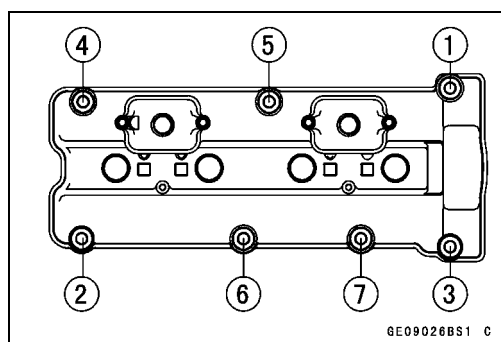
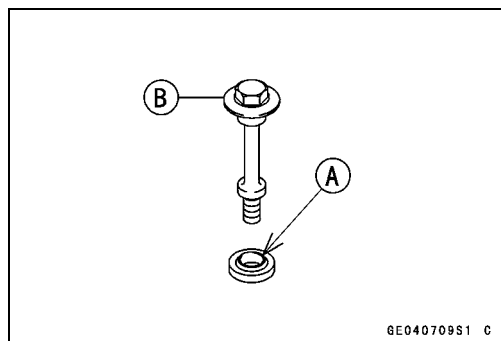

Camshaft Chain Tensioner

Camshaft Chain Tensioner Removal

CAUTION

This is a non-return type camshaft chain tensioner. The push rod does not return to its original position once it moves out to take up camshaft chain slack. Observe all the rules listed below:

When removing the tensioner, do not take out the mounting bolts only halfway. Retightening the mounting bolts from this position could damage the tensioner and the camshaft chain. Once the bolts are loosened, the tensioner must be removed and reset as described in "Camshaft Chain Tensioner Installation."

Do not turn over the crankshaft while the tensioner is removed. This could upset the camshaft chain timing, and damage the valves.

- Remove:
 - Cap Bolt [A]
 - Washer [B]
 - Spring [C]
 - Rod [D]
- Remove the mounting bolts [E] and take off the camshaft chain tensioner.

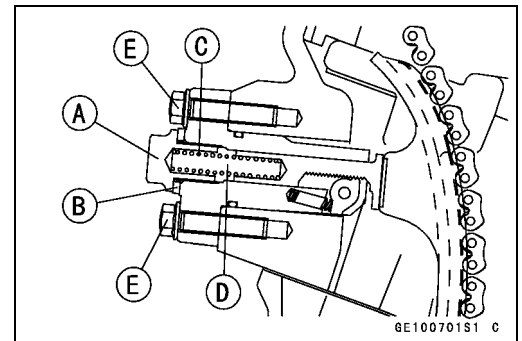

Camshaft Chain Tensioner Installation

- Release the stopper [A] and push the push rod [B] into the tensioner body [C].
- Insert the push rod so that the push rod teeth are leaved three (3) notches.
- Install the tensioner body so that the stopper faces downward.
- Apply a non-permanent locking agent to the tensioner mounting bolts [A].
- Tighten the tensioner mounting bolts.

Torque - Camshaft Chain Tensioner Mounting Bolts: 10 N·m (1.0 kgf·m, 89 in·lb)
- Install the spring [B], rod [C] and washer.
- Tighten the cap bolt [D].

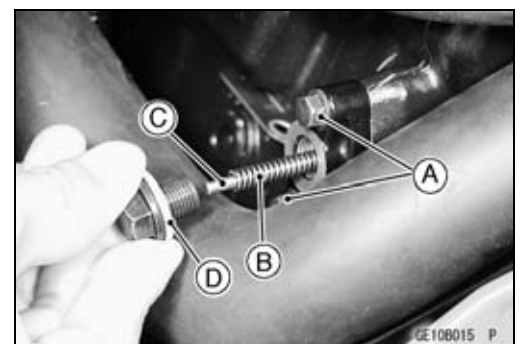
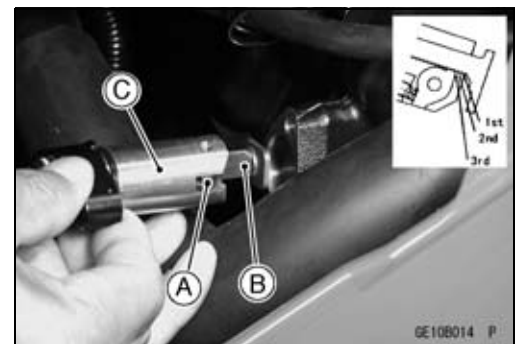

5-14 ENGINE TOP END

Camshaft, Camshaft Chain

Camshaft Removal

- Remove:
 - Lower Fairings with Lower Inner Fairing (see Frame chapter)
 - Lower Inner Covers (see Frame chapter)
 - Cylinder Head Cover (see Cylinder Head Cover Removal)
 - Crankshaft Sensor Cover (see Electrical System chapter)
- Position the crankshaft at #1, #4 piston TDC.
 - TDC Mark [A] for #1, #4 Pistons
 - Timing Mark [B] (crankcase halves mating surface)
- Remove:
 - Camshaft Chain Tensioner (see Camshaft Chain Tensioner Removal)
 - Camshaft Cap Bolts [A]
 - Upper Camshaft Chain Guide [B]
 - Camshaft Cap [C]
 - Camshafts [D]
- Stuff a clean cloth into the chain tunnel to keep any parts from dropping into the crankcase.

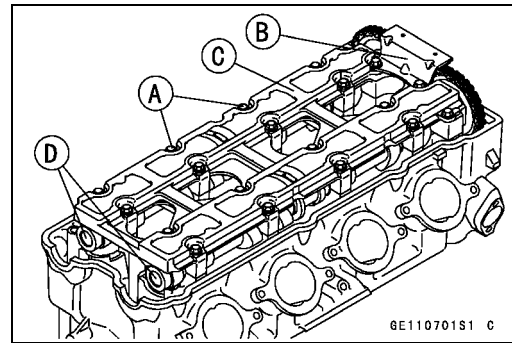
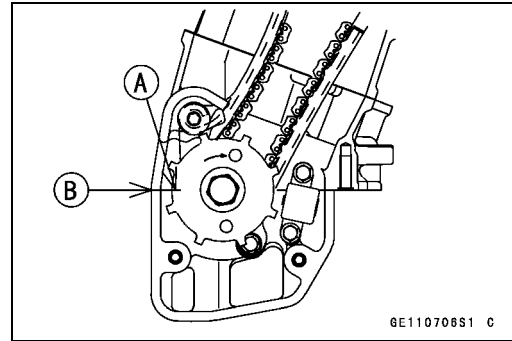

CAUTION

The crankshaft may be turned while the camshafts are removed. Always pull the chain taut while turning the crankshaft. This avoids kinking the chain on the lower (crankshaft) sprocket. A kinked chain could damage both the chain and the sprocket.

Camshaft Installation

- Be sure to install the following parts.
 - Pins [A]
- Apply molybdenum disulfide oil solution to all cam parts and journals.
- ★ If a new camshaft is to be used, apply molybdenum disulfide grease to the cam surfaces.

NOTE

○ The exhaust camshaft has a 320 EX mark [A] and the inlet camshaft has a 320 IN mark [B]. Be careful not to mix up these shafts.

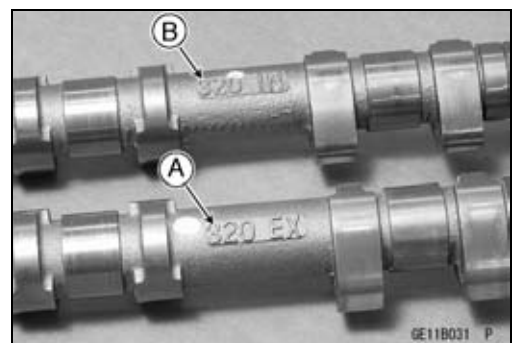
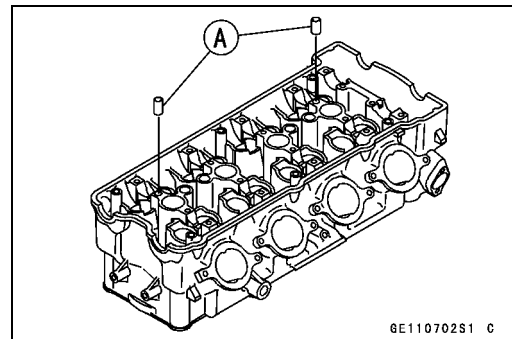

Camshaft, Camshaft Chain

★If the camshaft position sensor rotor is removed, install it as follows.

○Insert the pin [A] into the holes [B] in the camshaft and boss [C].

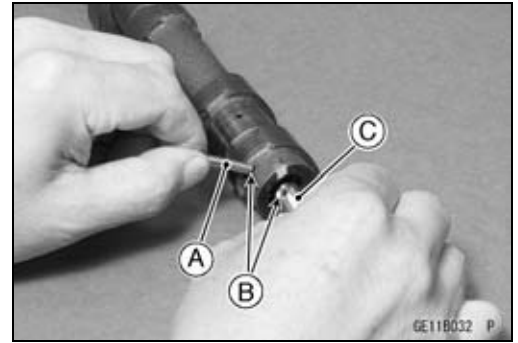

○Fit the projection [A] of the rotor on the camshaft recess [B].

○Apply a non-permanent locking agent to the camshaft position sensor rotor bolt [C], and tighten it.

Torque - Camshaft Position Sensor Rotor Bolt: 12 N·m (1.2 kgf·m, 106 in·lb)

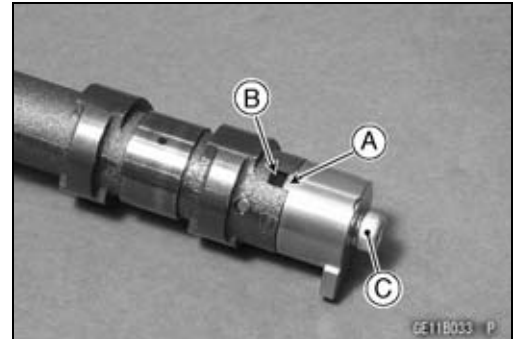

- Position the crankshaft at #1, #4 piston TDC.
- Pull the tension side (exhaust side) [A] of the chain taut to install the chain
- Engage the camshaft chain with the camshaft sprockets so that the timing marks on the sprockets are positioned as shown.
- The timing mark [B] of #1, #4 T must be aligned with the mating surface [C] of crankcase of rear side.
- The timing marks must be aligned with the cylinder head upper surface [D].

EX mark [E]

IN mark [F]

#1 Pin [G]

#31 Pin [H]

#32 Pin [I]

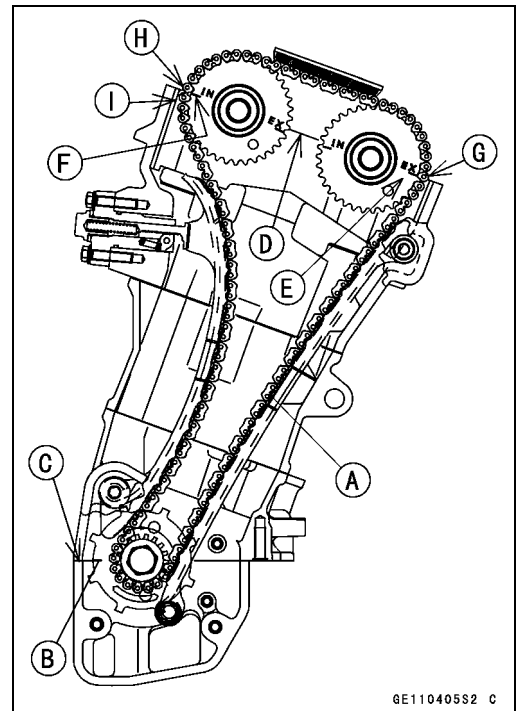

5-16 ENGINE TOP END

Camshaft, Camshaft Chain

- Install the camshaft cap [A] and upper camshaft chain guide [B]. While pushing the camshaft chain, tighten all camshaft bolts and chain guide bolts.
- Install the longer bolts to the #10 and #14 position shown by triangle marks.
- First tighten the all camshaft cap and chain guide bolts evenly to seat the camshaft in place, then tighten all bolts following the specified tightening sequence.

Torque - Camshaft Cap Bolts: 12 N·m (1.2 kgf·m, 106 in·lb)
Upper Camshaft Chain Guide Bolts: 12 N·m (1.2 kgf·m, 106 in·lb)

- Install the camshaft chain tensioner (see Camshaft Chain Tensioner Installation).
- Install the cylinder head cover (see Cylinder Head Cover Installation).

Camshaft, Camshaft Cap Wear

- Cut strips of plastigage (press gauge) to journal width. Place a strip on each journal parallel to the camshaft installed in the correct position.
- Measure each clearance between the camshaft journal and the camshaft cap using plastigage [A].
- Tighten:

Torque - Camshaft Cap Bolts: 12 N·m (1.2 kgf·m, 106 in·lb)
Upper Camshaft Chain Guide Bolts: 12 N·m (1.2 kgf·m, 106 in·lb)

NOTE

- Do not turn the camshaft when the plastigage is between the journal and camshaft cap.

Camshaft Journal, Camshaft Cap Clearance

Standard: 0.028 ~ 0.071 mm (0.0011 ~ 0.0028 in.)
Service Limit: 0.16 mm (0.006 in.)

- ★ If any clearance exceeds the service limit, measure the diameter of each camshaft journal with a micrometer.

Camshaft Journal Diameter

Standard: 23.950 ~ 23.972 mm (0.9429 ~ 0.9438 in.)
Service Limit: 23.92 mm (0.942 in.)

- ★ If the camshaft journal diameter is less than the service limit, replace the camshaft with a new one and measure the clearance again
- ★ If the clearance still remains out of the limit, replace the cylinder head with camshaft cap.

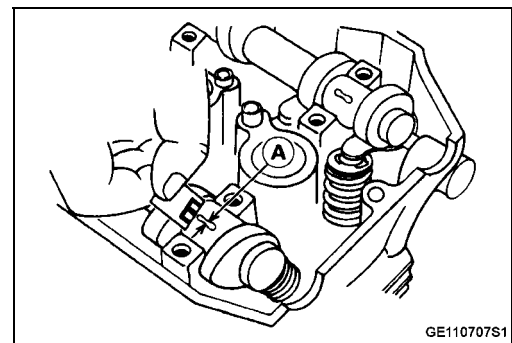
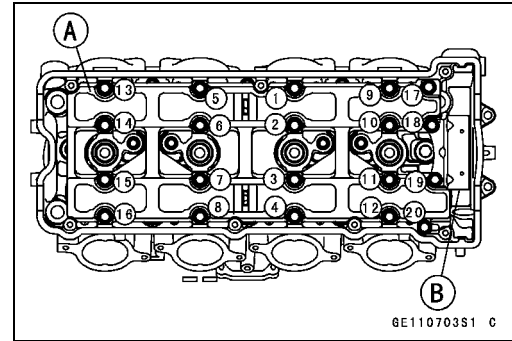

Camshaft, Camshaft Chain

Camshaft Runout

- Remove the camshaft (see Camshaft Removal).
- Set the camshaft in a camshaft alignment jig or on V blocks.
- Measure runout with a dial gauge at the specified place as shown.
- ★ If the runout exceeds the service limit, replace the camshaft.

Camshaft Runout

Standard: TIR 0.02 mm (0.0008 in.) or less

Service Limit: TIR 0.1 mm (0.004 in.)

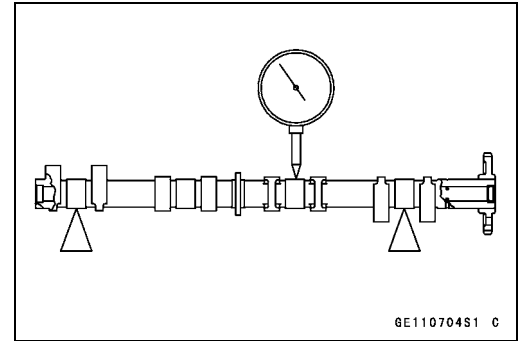

Cam Wear

- Remove the camshaft (see Camshaft Removal).
- Measure the height [A] of each cam with a micrometer.
- ★ If the cams are worn down past the service limit, replace the camshaft.

Cam Height

Standard:

Exhaust 36.643 ~ 36.757 mm (1.4426 ~ 1.4471 in.)

Inlet 37.043 ~ 37.157 mm (1.4584 ~ 1.4629 in.)

Service Limit:

Exhaust 36.54 mm (1.439 in.)

Inlet 36.94 mm (1.454 in.)

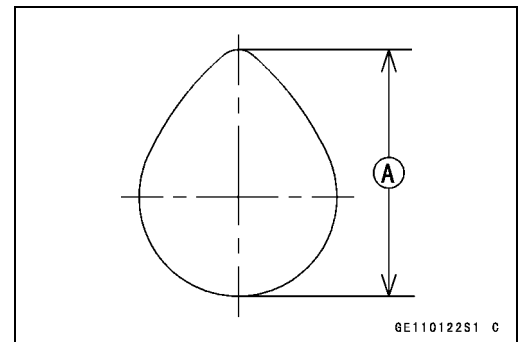

Camshaft Chain Removal

- Split the crankcase (see Crankshaft/Transmission chapter).
- Remove the camshaft chain [A] from the crankshaft sprocket.

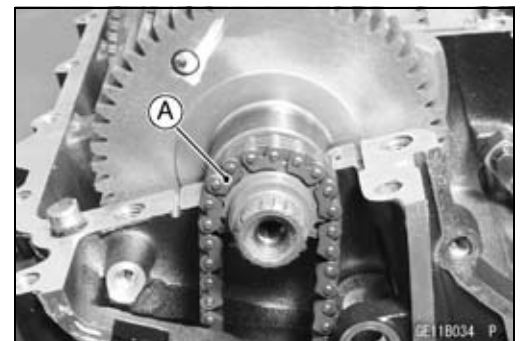

5-18 ENGINE TOP END

Cylinder Head

Cylinder Compression Measurement

NOTE

○ Use the battery which is fully charged.

- Warm up the engine thoroughly.
- Stop the engine.
- Remove:
 - Lower Inner Covers (see Frame chapter)
 - Baffle Plate (see Cylinder Head Cover Removal)
 - Stick Coils (see Electrical System chapter)
 - Spark Plugs (see Electrical System chapter)
- Attach the compression gauge [A] and adapter [B] firmly into the spark plug hole.
- Using the starter motor, turn the engine with the throttle fully open until the compression gauge stops rising; the compression is the highest reading obtainable.

Special Tools - Compression Gauge: 57001-221

**Compression Gauge Adapter, M10 × 1.0:
57001-1458**

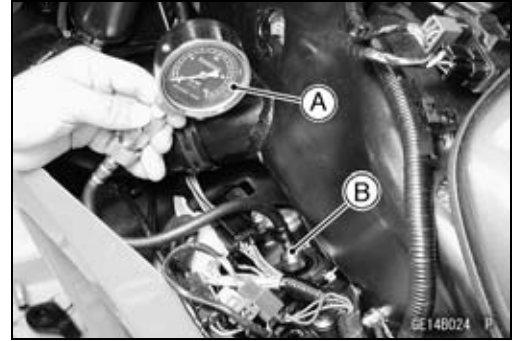

Cylinder Compression

**Usable Range: 1029 ~ 1568 kPa (10.5 ~ 16 kgf/cm²,
149 ~ 228 psi) @300 r/min (rpm)**

- Repeat the measurement for the other cylinders.
- Install the spark plugs.

Torque - Spark Plugs: 13 N·m (1.3 kgf·m, 115 in·lb)

The following table should be consulted if the obtainable compression reading is not within the usable range.

Problem	Diagnosis	Remedy (Action)
Cylinder compression is higher than usable range	Carbon accumulation on piston and in combustion chamber possibly due to damaged valve stem oil seal and/or damaged piston oil rings (This may be indicated by white exhaust smoke)	Remove the carbon deposits and replace damaged parts if necessary.
	Incorrect cylinder head gasket thickness.	Replace the gasket with a standard part.
Cylinder compression is lower than usable range	Gas leakage around cylinder head	Replace damaged gasket and check cylinder head warp.
	Bad condition of valve seating	Repair if necessary.
	Incorrect valve clearance	Adjust the valve clearance.
	Incorrect piston/cylinder clearance	Replace the piston and/or cylinder.
	Piston seizure	Inspect the cylinder and replace/repair the cylinder and/or piston as necessary.
	Bad condition of piston ring and/or piston ring grooves	Replace the piston and/or the piston rings.

Cylinder Head

Cylinder Head Removal

- Drain the coolant (see Coolant Change in the Periodic Maintenance chapter).
- Remove:
 - Radiator (see Cooling System chapter)
 - Muffler (see Muffler Removal)
 - Clutch Cable Lower End (see Clutch chapter)
 - Engine Mounting Bolts [C]
 - Engine Bracket Bolts [A]
 - Engine Brackets [B]
 - Throttle Body Assy (see Fuel System (DFI) chapter)
 - Cylinder Head Cover (see Cylinder Head Cover Removal)
 - Camshaft Position Sensor (see Electrical System chapter)
 - Camshaft Chain Tensioner (see Camshaft Chain Tensioner Removal)
 - Camshafts (see Camshaft Removal)
- Remove:
 - Cooling Hose [A]

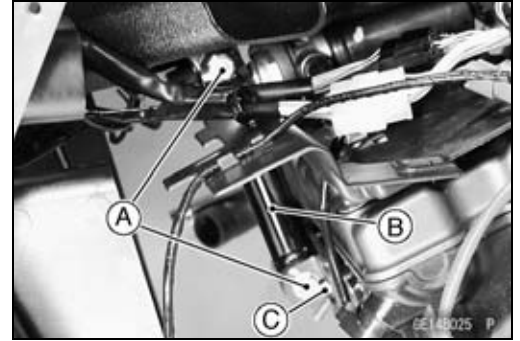

- Remove:
 - Camshaft Chain Guide Bolts [A]
 - Front and Rear Camshaft Chain Guides
- Pull up the camshaft chain guides from the cylinder head with pliers.



- Remove the M7 cylinder head bolts [A], and then the M11 cylinder head bolts [B].
- Take off the cylinder head.

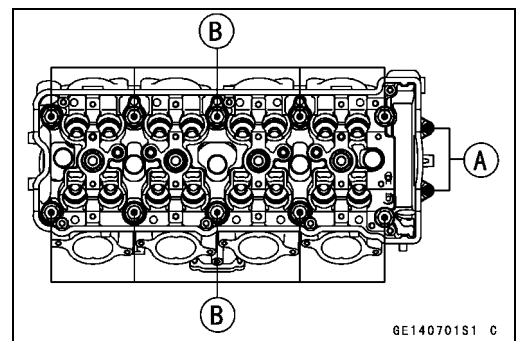

5-20 ENGINE TOP END

Cylinder Head

Cylinder Head Installation

NOTE

○The camshaft cap is machined with the cylinder head, so if a new cylinder head is installed, use the cap that is supplied with the new head.

- Make sure that the O-ring [A] of the oil pipe is not damaged, and apply high-temperature grease to it.
- Verify that the oil pipe [B] is installed properly.
- Install a new cylinder head gasket [C], and knock pins [D].
- Apply molybdenum disulfide oil solution to both sides [A] of the cylinder head bolt washers [B] and the thread of head bolts [C].

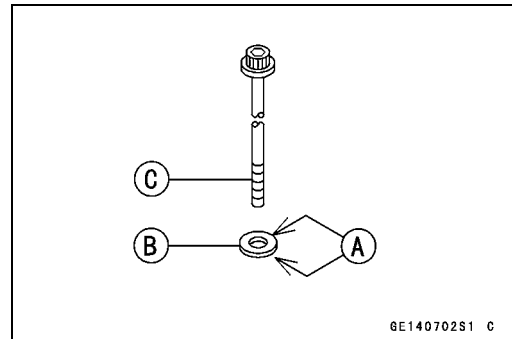
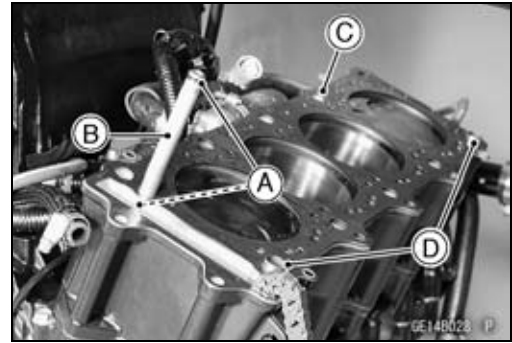

- Tighten the M11 cylinder head bolts following the tightening sequence [1 ~ 10].

Torque - Cylinder Head Bolts (M11):

First: 23 N·m (2.3 kgf·m, 17 ft·lb)

Final: 59 N·m (6.0 kgf·m, 44 ft·lb)

- Tighten the M7 cylinder head bolts [11 ~ 12].

Torque - Cylinder Head Bolts (M7): 20 N·m (2.0 kgf·m, 15 ft·lb)

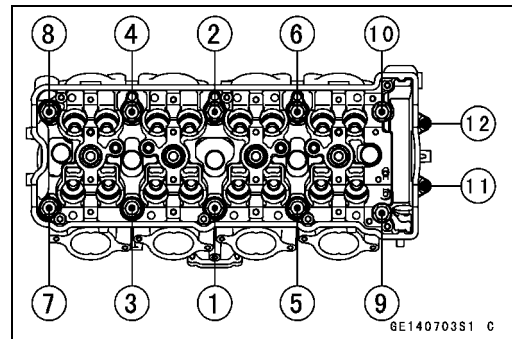

- Install:
 - Front Camshaft Chain Guide [A]
 - O-ring [B]
 - Collar [C]

- Tighten:

Torque - Front Camshaft Chain Guide Bolt (Upper) [D]:

25 N·m (2.5 kgf·m, 18 ft·lb)

Front Camshaft Chain Guide Bolt (Lower) [E]:

12 N·m (1.2 kgf·m, 106 in·lb)

- Install:
 - Rear Camshaft Chain Guide [F]

- Tighten:

Torque - Rear Camshaft Chain Guide Bolt [G]:

25 N·m (2.5 kgf·m, 18 ft·lb)

- Install the camshafts (see Camshaft Installation).

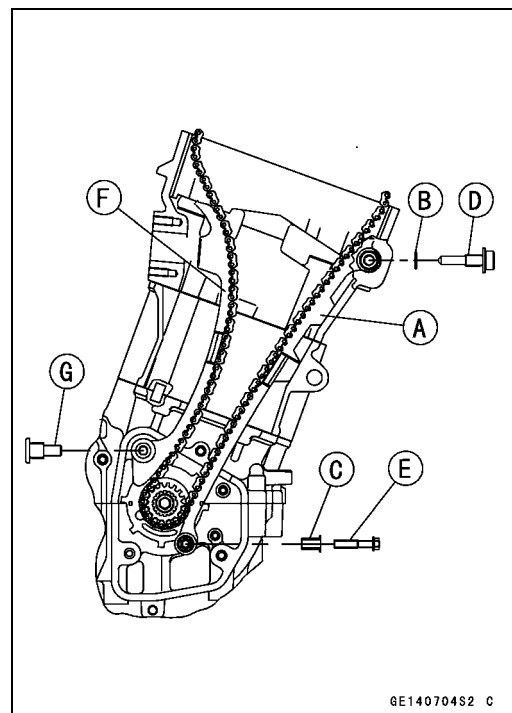

Cylinder Head

Cylinder Head Warp

- Clean the cylinder head.
- Lay a straightedge across the lower surface of the cylinder head at several positions.
- Measure the space between the straightedge [B] and the head with a thickness gauge [A].

Cylinder Head Warp

Standard: - - -

Service Limit: 0.05 mm (0.002 in.)

- ★ If the cylinder head is warped more than the service limit, replace it.
- ★ If the cylinder head is warped less than the service limit, repair the head by rubbing the lower surface on emery paper secured to a surface plate (first No. 200, then No. 400).

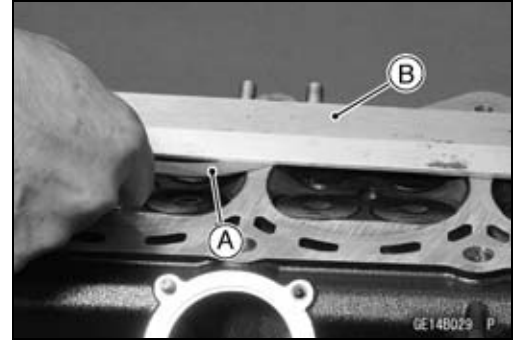

5-22 ENGINE TOP END

Valves

Valve Clearance Check

- Refer to the Valve Clearance Inspection and Adjustment in the Periodic Maintenance chapter (2nd chapter).

Valve Removal

- Remove the cylinder head (see Cylinder Head Removal).
- Remove the valve lifter and shim.
- Mark and record the valve lifter and shim locations so they can be installed in their original positions.
- Using the valve spring compressor assembly, remove the valve.

**Special Tools - Valve Spring Compressor Assembly: 57001-241 [A]
Adapter, ϕ 22: 57001-1202 [B]**

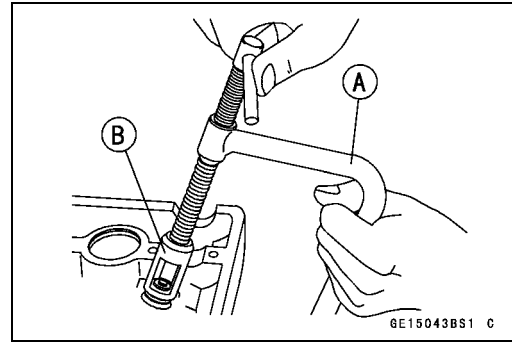

Valve Installation

- Replace the oil seal with a new one.
- Apply thin coat of molybdenum disulfide grease to the valve stem before valve installation.
- Install the springs so that the closed coil end faces downwards.

Valve Spring Paint Color: EX - Red
IN - Blue

Valve Stem [A]

Oil Seal [B]

Spring Seat [C]

Closed Coil End [D]

Valve Springs (Inner) [E]

Valve Springs (Outer) [F]

Retainer [G]

Split Keepers [H]

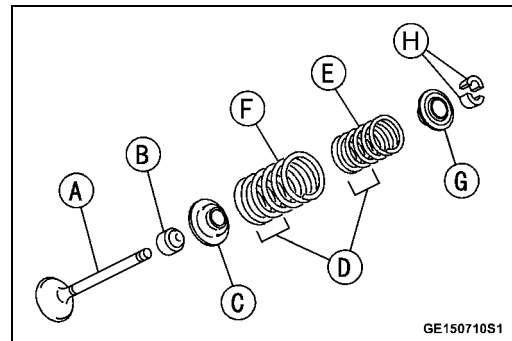

Valve Guide Removal

- Remove:
 - Valve (see Valve Removal)
 - Oil Seal
 - Spring Seat
- Heat the area around the valve guide to 120 ~ 150°C (248 ~ 302°F), and hammer lightly on the valve guide arbor [A] to remove the guide from the top of the head.

CAUTION

Do not heat the cylinder head with a torch. This will warp the cylinder head. Soak the cylinder head in oil and heat the oil.

Special Tool - Valve Guide Arbor, ϕ 5.0: 57001-1203

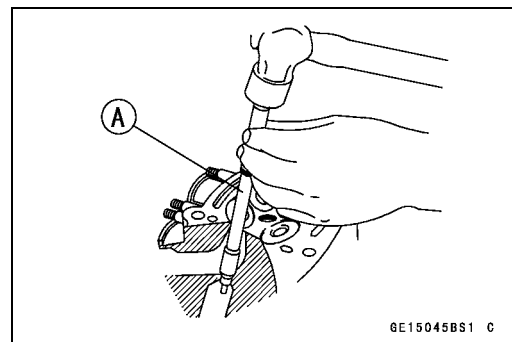

Valves

Valve Guide Installation

- Apply engine oil to the valve guide outer surface before installation.
- Heat the area around the valve guide hole to about 120 ~ 150°C (248 ~ 302°F).
- Drive the valve guide in from the top of the head using the valve guide arbor. The flange stops the guide from going in too far.

Special Tool - Valve Guide Arbor, ϕ 5.0: 57001-1203

- Ream the valve guide with valve guide reamer [A] even if the old guide is reused.

Special Tool - Valve Guide Reamer, ϕ 5.0: 57001-1204

Valve-to-Guide Clearance Measurement (Wobble Method)

If a small bore gauge is not available, inspect the valve guide wear by measuring the valve to valve guide clearance with the wobble method as indicated below.

- Insert a new valve [A] into the guide [B] and set a dial gauge against the stem perpendicular to it as close as possible to the cylinder head mating surface.
 - Move the stem back and forth [C] to measure valve/valve guide clearance.
 - Repeat the measurement in a direction at a right angle to the first.
- ★If the reading exceeds the service limit, replace the guide.

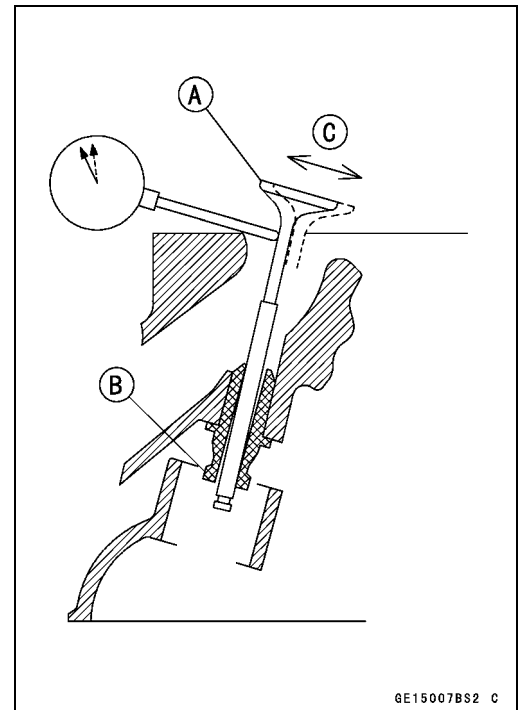
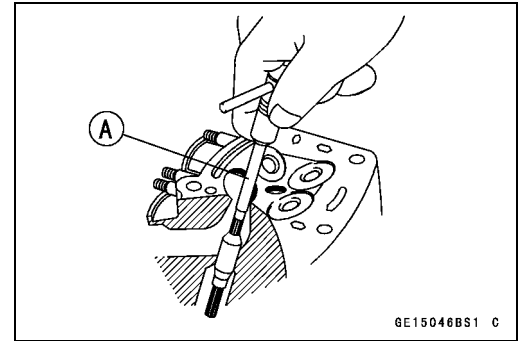

NOTE

- The reading is not actual valve/valve guide clearance because the measuring point is above the guide.

Valve/Valve Guide Clearance (Wobble Method)

Standard:

Exhaust	0.09 ~ 0.17 mm (0.0035 ~ 0.0067 in.)
Inlet	0.03 ~ 0.11 mm (0.0012 ~ 0.0043 in.)

Service Limit:

Exhaust	0.35 mm (0.014 in.)
Inlet	0.29 mm (0.011 in.)

5-24 ENGINE TOP END

Valves

Valve Seat Inspection

- Remove the valve (see Valve Removal).
- Check the valve seating surface [A] between the valve [B] and valve seat [C].
- Measure the outside diameter [D] of the seating pattern on the valve seat.
- ★ If the outside diameter is too large or too small, repair the seat (see Seat Repair).

Valve Seating Surface Outside Diameter

Standard:

Exhaust	27.6 ~ 27.8 mm (1.086 ~ 1.094 in.)
Inlet	32.6 ~ 32.8 mm (1.283 ~ 1.291 in.)

- Measure the seat width [E] of the portion where there is no build-up carbon (white portion) of the valve seat with a vernier caliper.

Good [F]

- ★ If the width is too wide [G], too narrow [H] or uneven [J], repair the seat (see Valve Seat Repair).

Valve Seating Surface Width

Standard:

Exhaust	0.8 ~ 1.2 mm (0.03 ~ 0.047 in.)
Inlet	0.5 ~ 1.0 mm (0.02 ~ 0.039 in.)

Valve Seat Repair

- Repair the valve seat with the valve seat cutters [A].

Special Tools - Valve Seat Cutter Holder Bar: 57001-1128 [C]

Valve Seat Cutter Holder, ϕ 5.0: 57001-1208 [B]

[For Exhaust Valve Seat]

Valve Seat Cutter, 45° - ϕ 30: 57001-1187

Valve Seat Cutter, 32° - ϕ 30: 57001-1120

Valve Seat Cutter, 60° - ϕ 30: 57001-1123

[For Inlet Valve Seat]

Valve Seat Cutter, 45° - ϕ 35: 57001-1116

Valve Seat Cutter, 32° - ϕ 35: 57001-1121

Valve Seat Cutter, 55° - ϕ 35: 57001-1247

- ★ If the manufacturer's instructions are not available, use the following procedure.

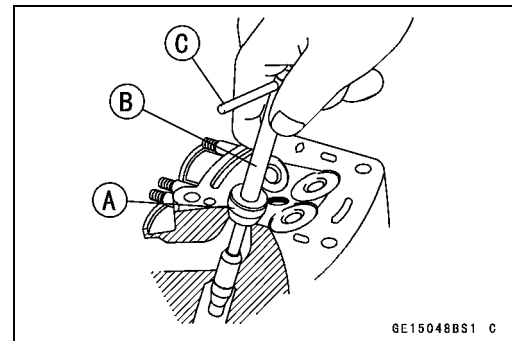
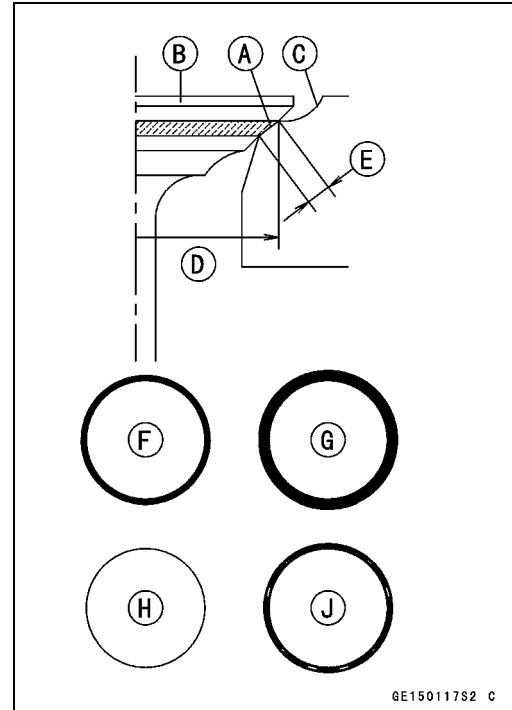

Valves

Seat Cutter Operation Care:

1. This valve seat cutter is developed to grind the valve for repair. Therefore the cutter must not be used for other purposes than seat repair.
2. Do not drop or shock the valve seat cutter, or the diamond particles may fall off.
3. Do not fail to apply engine oil to the valve seat cutter before grinding the seat surface. Also wash off ground particles sticking to the cutter with washing oil.

NOTE

○Do not use a wire brush to remove the metal particles from the cutter. It will take off the diamond particles.

4. Setting the valve seat cutter holder in position, operate the cutter in one hand. Do not apply too much force to the diamond portion.

NOTE

○Prior to grinding, apply engine oil to the cutter and during the operation, wash off any ground particles sticking to the cutter with washing oil.

5. After use, wash it with washing oil and apply thin layer of engine oil before storing.

Marks Stamped on the Cutter

The marks stamped on the back of the cutter [A] represent the following.

- 60° Cutter angle [B]
- φ37.5 Outer diameter of cutter [C]

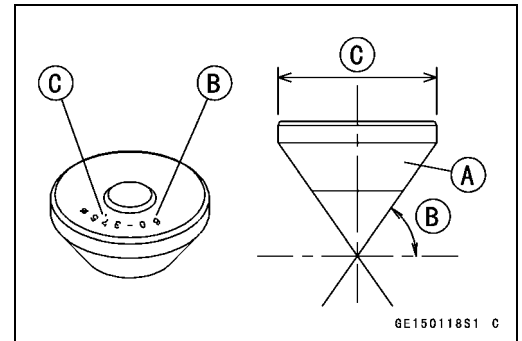

Operating Procedures

- Clean the seat area carefully.
- Coat the seat with machinist's dye.
- Fit a 45° cutter into the holder and slide it into the valve guide.
- Press down lightly on the handle and turn it right or left. Grind the seating surface only until it is smooth.

CAUTION

Do not grind the seat too much. Overgrinding will reduce valve clearance by sinking the valve into the head. If the valve sinks too far into the head, it will be impossible to adjust the clearance, and the cylinder head must be replaced.

5-26 ENGINE TOP END

Valves

- Measure the outside diameter of the seating surface with a vernier caliper.

★ If the outside diameter of the seating surface is too small, repeat the 45° grind until the diameter is within the specified range.

Widened Width [A] of engagement by machining with 45° cutter

Ground Volume [B] by 32° cutter

32° [C]

Correct Width [D]

Ground Volume [E] by 60° or 55° cutter

60° or 55° [F]

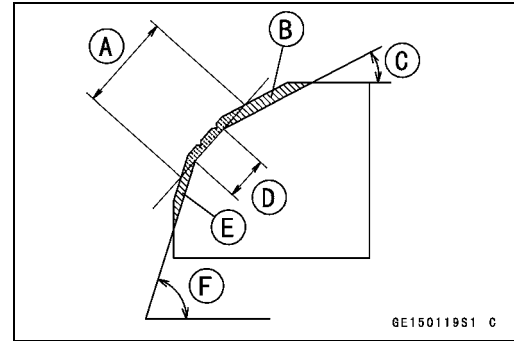

- Measure the outside diameter of the seating surface with a vernier caliper.

★ If the outside diameter of the seating surface is too small, repeat the 45° grind [A] until the diameter is within the specified range.

Original Seating Surface [B]

NOTE

- Remove all pittings of flaws from 45° ground surface.
- After grinding with 45° cutter, apply thin coat of machinist's dye to seating surface. This makes seating surface distinct and 32° and 60° grinding operation easier.
- When the valve guide is replaced, be sure to grind with 45° cutter for centering and good contact.

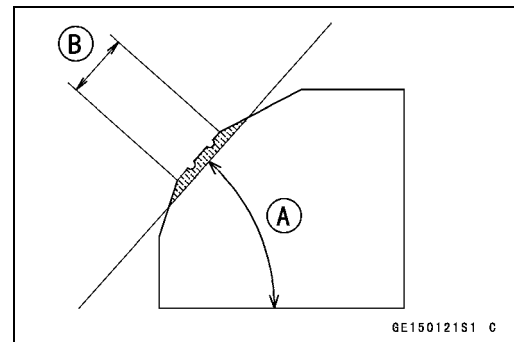

★ If the outside diameter [A] of the seating surface is too large, make the 32° grind described below.

★ If the outside diameter of the seating surface is within the specified range, measure the seat width as described below.

- Grind the seat at a 32° angle [B] until the seat O.D. is within the specified range.

○ To make the 32° grind, fit a 32° cutter into the holder, and slide it into the valve guide.

○ Turn the holder one turn at a time while pressing down very lightly. Check the seat after each turn.

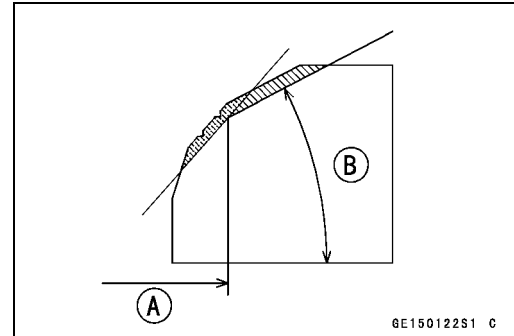

CAUTION

The 32° cutter removes material very quickly. Check the seat outside diameter frequently to prevent overgrinding.

○ After making the 32° grind, return to the seat O.D. measurement step above.

● To measure the seat width, use a vernier caliper to measure the width of the 45° angle portion of the seat at several places around the seat.

★ If the seat width is too narrow, repeat the 45° grind until the seat is slightly too wide, and then return to the seat O.D. measurement step above.

Valves

- ★ If the seat width is too wide, make the 60° or 55° [A] grind described below.
 - ★ If the seat width is within the specified range, lap the valve to the seat as described below.
 - Grind the seat at a 60° or 55° angle until the seat width is within the specified range.
 - To make the 60° or 55° grind, fit 60° or 55° cutter into the holder, and slide it into the valve guide.
 - Turn the holder, while pressing down lightly.
 - After making the 60° or 55° grind, return to the seat width measurement step above.
- Correct Width [B]

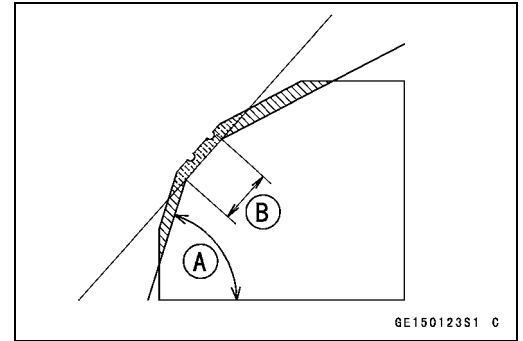

- Lap the valve to the seat, once the seat width and O.D. are within the ranges specified above.
 - Put a little coarse grinding compound on the face of the valve in a number of places around the valve head.
 - Spin the valve against the seat until the grinding compound produces a smooth, matched surface on both the seat and the valve.
 - Repeat the process with a fine grinding compound.
- Lapper [A]
Valve Seat [B]
Valve [C]
- The seating area should be marked about in the middle of the valve face.
 - ★ If the seat area is not in the right place on the valve, check to be sure the valve is the correct part. If it is, it may have been refused too much; replace it.
 - Be sure to remove all grinding compound before assembly.
 - When the engine is assembled, be sure to adjust the valve clearance (see Valve Clearance Adjustment section of Periodic Maintenance chapter).

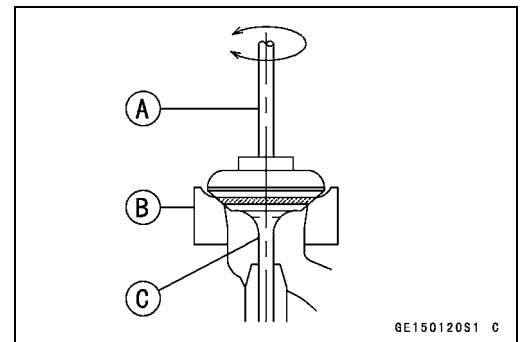

5-28 ENGINE TOP END

Valves

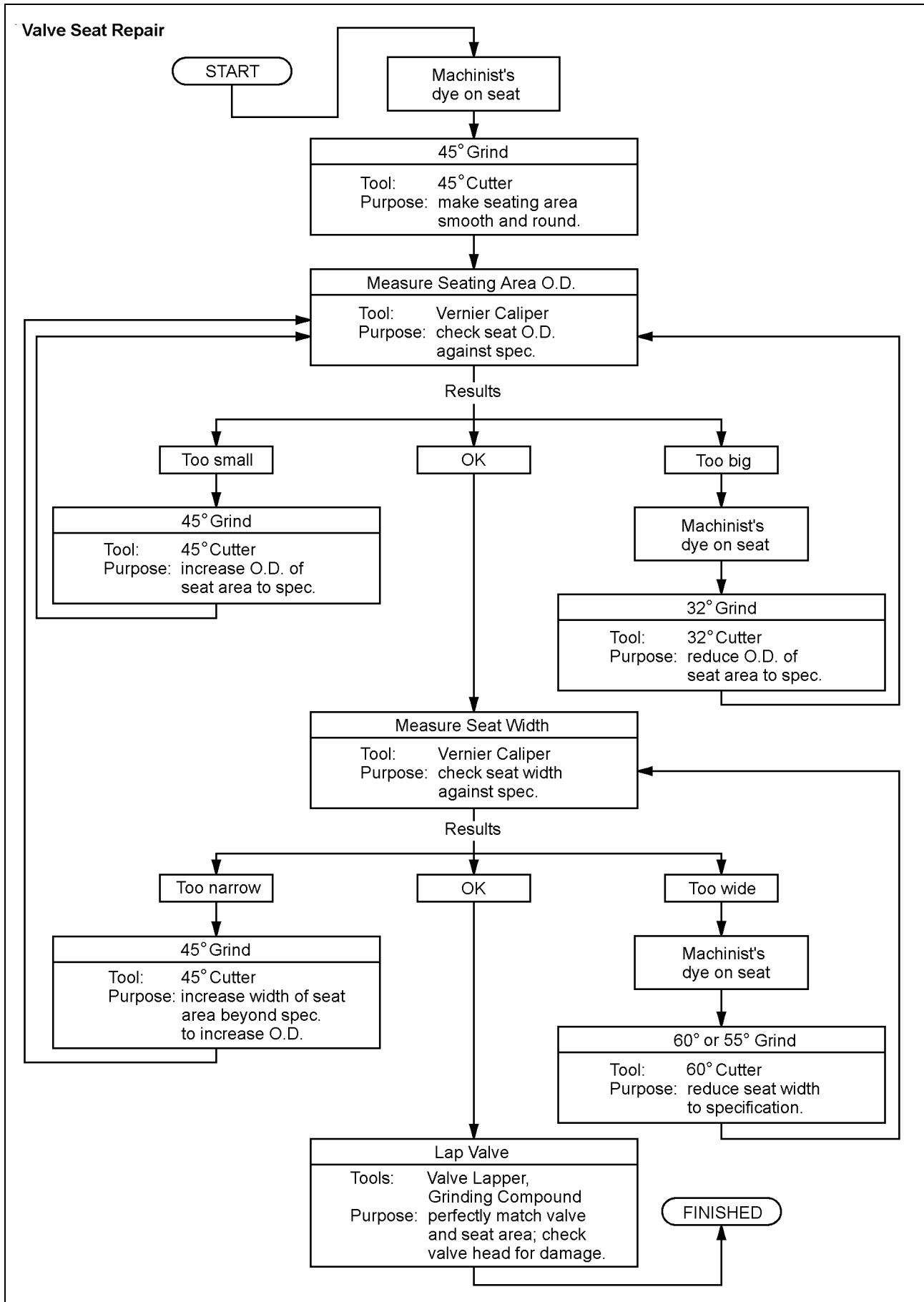

Cylinder, Pistons

Cylinder Removal

- Remove:
 - Cylinder Head (see Cylinder Head Removal)
 - Cooling Hoses [A]
 - Oil Pipe [B]
- Remove the cylinder [C].

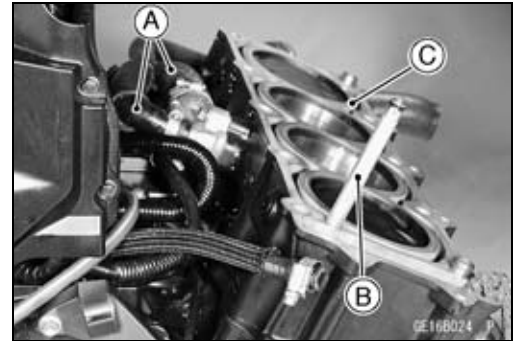

Cylinder Installation

NOTE

- If a new cylinder is used, use new piston rings.
- If new pistons and/or a new cylinder are installed, apply thin coat of molybdenum disulfide grease to the new pistons and cylinder bores.
- Replace the cylinder gasket with a new one, and install the pins [A] and new cylinder gasket.
- Apply molybdenum disulfide oil solution to the cylinder bore, external of pistons and piston rings.



- The piston ring openings must be positioned as shown in the figure. The openings of the oil ring steel rails must be about 30 ~ 40° of angle from the opening of the top ring.
 - Top Ring [A]
 - Second Ring [B]
 - Oil Ring Steel Rails [C]
 - Oil Ring Expander [D]
 - Hollow [E]

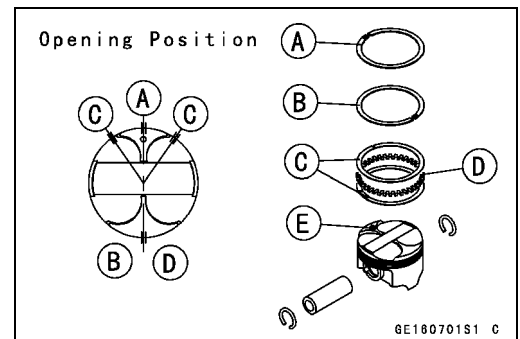

- Insert the piston in the cylinder by two methods.

With the Hand

- Position the crankshaft at #2, #3 piston TDC.
- Install the two cylinder head bolts [A] diagonally in the crankcase.
- Install the cylinder block [B].
 - Pistons [C]
- First insert the #2, #3 pistons, and then rotate the crankshaft at 90° angle.
- Insert the piston rings with your thumbs or the thin (-) screw driver.

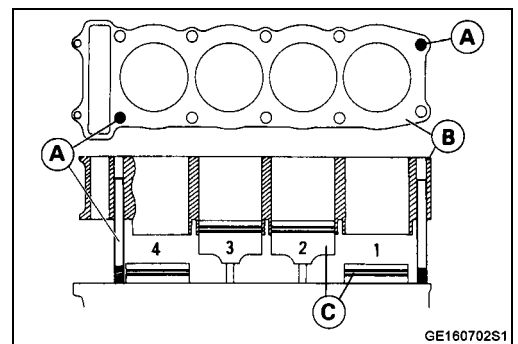

5-30 ENGINE TOP END

Cylinder, Pistons

With the Special Tools

- Install the two cylinder head bolts [A] diagonally in the crankcase.
- Slip the piston bases [B] under the pistons to hold them level.
- Compress the piston rings using the piston ring compressor grips [C] and piston ring compressor belts [D] with chamfered side upward.

Special Tools - Piston Ring Compressor Grip: 57001-1095

**Piston Ring Compressor Belt, $\phi 80 \sim 91$:
57001-1320**

Piston Base, $\phi 1.0$: 57001-1459

- Push down vigorously the cylinder aligning the cylinder bores with all the piston heads.
- Install the cylinder [A] so that its angle aligns the piston angle after removing the piston ring compressor belts.

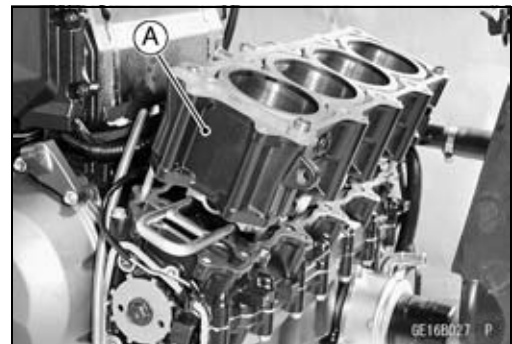
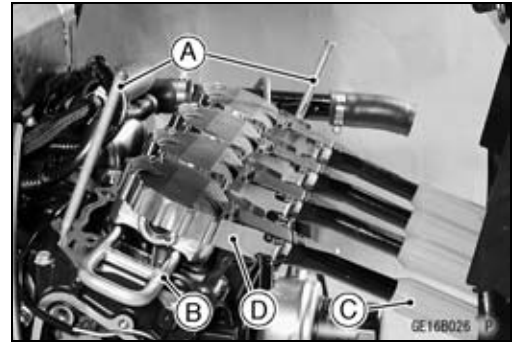

Piston Removal

- Remove the cylinder (see Cylinder Removal).
- Place a clean cloth under the pistons and remove the piston pin snap ring [A] from the outside of each piston.

CAUTION

Do not reuse the snap rings, as removal weakens deforms them. They fall out and score the cylinder wall.



- Remove the piston pins with a piston pin puller [A].
Special Tool - Piston Pin Puller Assembly: 57001-910
- Remove the pistons.

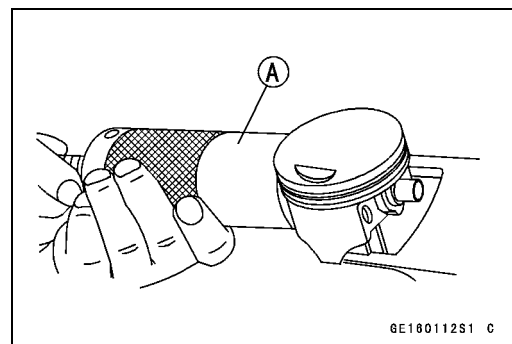

Cylinder, Pistons

- Carefully spread the ring opening with your thumbs and then push up on the opposite side of the ring [A] to remove it.
- Remove the 3-piece oil ring with your thumbs in the same manner.

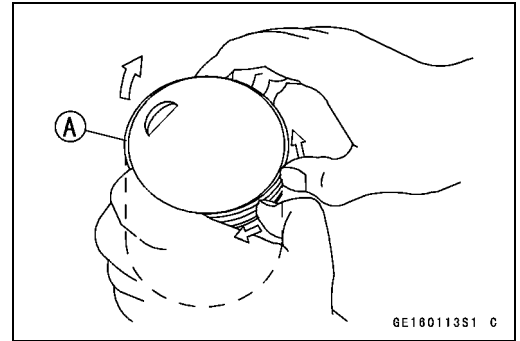

Piston Installation

- Apply molybdenum disulfide oil solution to the oil ring expander, and install the oil ring expander [A] in the bottom piston ring groove so the ends [B] butt together.
- Apply molybdenum disulfide oil solution to the oil ring steel rails, and install the oil ring steel rails, one above the expander and one below it.
- Spread the rail with your thumbs, but only enough to fit the rail over the piston.
- Release the rail into the bottom piston ring groove.

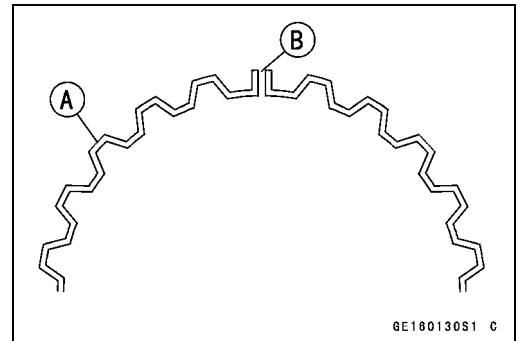

NOTE

○ The oil ring rails have no "top" or "bottom".

- Do not mix up the top and second ring.
- Install the top ring [A] so that the "R" mark [B] faces up.
- Install the second ring [C] so that the "RN" mark [D] faces up.
- Apply molybdenum disulfide oil solution to the piston rings.

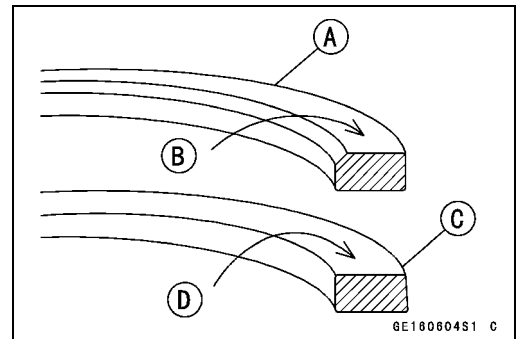

NOTE

○ If a new piston is used, use new piston ring.

- Install the piston with its marking hollow facing forward.
- Fit a new piston pin snap ring into the side of the piston so that the ring opening [A] does not coincide with the slit [B] of the piston pin hole.
- Apply molybdenum disulfide oil solution to the piston pins and piston journals.
- When installing the piston pin snap ring, compress it only enough to install it and no more.

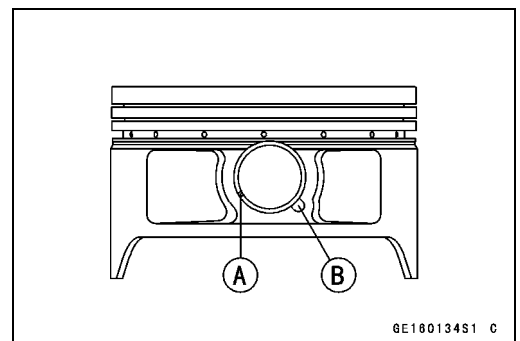

CAUTION

**Do not reuse snap rings, as removal weakens and deforms them.
They could fall out and score the cylinder wall.**

- Install the cylinder (see Cylinder Installation).

5-32 ENGINE TOP END

Cylinder, Pistons

Cylinder Wear

- Since there is a difference in cylinder wear in different directions, take a side-to-side and a front-to-back measurement at each of the two locations (total of four measurements) shown in the figure.

★ If any of the cylinder inside diameter measurements exceeds the service limit, replace the cylinder.

10 mm (0.39 in.) [A]

60 mm (2.36 in.) [B]

Cylinder Inside Diameter

Standard: 82.994 ~ 83.006 mm (3.2675 ~ 3.2679 in.)

Service Limit: 83.06 mm (3.270 in.)

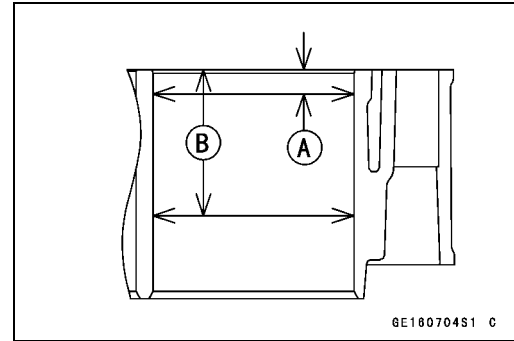

Piston Wear

- Measure the outside diameter [A] of each piston 18 mm (0.71 in.) [B] up from the bottom of the piston at a right angle to the direction of the piston pin

★ If the measurement is under service limit, replace the piston.

Piston Diameter

Standard: 82.969 ~ 82.984 mm (3.2665 ~ 3.2671 in.)

Service Limit: 82.82 mm (3.261 in.)

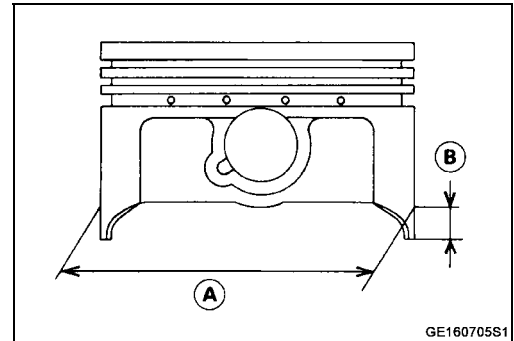

Piston Ring, Piston Ring Groove Wear

- Check for uneven groove wear by inspecting the ring seating.
- ★ The rings should fit perfectly parallel to groove surfaces. If not, replace the piston and all the piston rings.
- With the piston rings in their grooves, make several measurements with a thickness gauge [A] to determine piston ring/groove clearance.

Piston Ring/Groove Clearance

Standard:

Top 0.03 ~ 0.07 mm (0.0012 ~ 0.0028 in.)

Second 0.02 ~ 0.06 mm (0.0008 ~ 0.002 in.)

Service Limit:

Top 0.17 mm (0.0067 in.)

Second 0.16 mm (0.0063 in.)

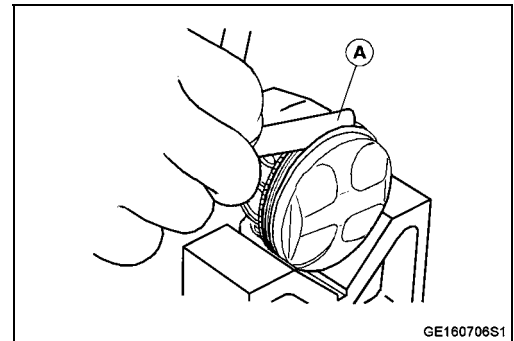

Piston Ring Groove Width

- Measure the piston ring groove width.
- Use a vernier caliper at several points around the piston.

Piston Ring Groove Width

Standard:

Top [A] 0.92 ~ 0.94 mm (0.0362 ~ 0.0370 in.)

Second [B] 1.01 ~ 1.03 mm (0.0398 ~ 0.0406 in.)

Service Limit:

Top [A] 1.02 mm (0.0402 in.)

Second [B] 1.11 mm (0.0437 in.)

★ If the width of any of the two grooves is wider than the service limit at any point, replace the piston.

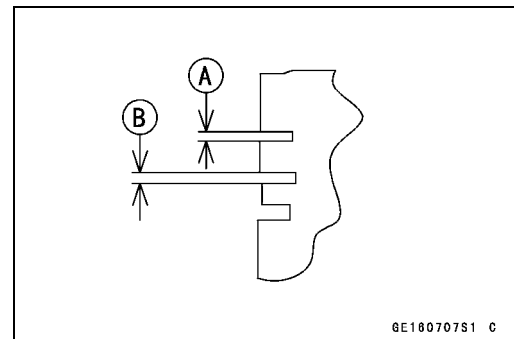

Cylinder, Pistons

Piston Ring Thickness

- Measure the piston ring thickness.
- Use the micrometer to measure at several points around the ring.

Piston Ring Thickness

Standard:

Top [A] 0.87 ~ 0.89 mm (0.0343 ~ 0.0350 in.)

Second [B] 0.97 ~ 0.99 mm (0.0382 ~ 0.0390 in.)

Service Limit:

Top [A] 0.80 mm (0.0315 in.)

Second [B] 0.90 mm (0.0354 in.)

- ★ If any of the measurements is less than the service limit on either of the rings, replace all the rings.

NOTE

- When using new rings in a used piston, check for uneven groove wear. The rings should fit perfectly parallel to the groove sides. If not, replace the piston.

Piston Ring End Gap

- Place the piston ring [A] inside the cylinder, using the piston to locate the ring squarely in place. Set it close to the bottom of the cylinder, where cylinder wear is low.
- Measure the gap between the ends of the ring with a thickness gauge [B].

Piston Ring End Gap

Standard:

Top 0.25 ~ 0.40 mm (0.0098 ~ 0.0157 in.)

Second 0.40 ~ 0.55 mm (0.0157 ~ 0.0217 in.)

Service Limit:

Top 0.7 mm (0.0276 in.)

Second 0.8 mm (0.0315 in.)

- ★ If the end gap of either ring is greater than the service limit, replace all the rings.

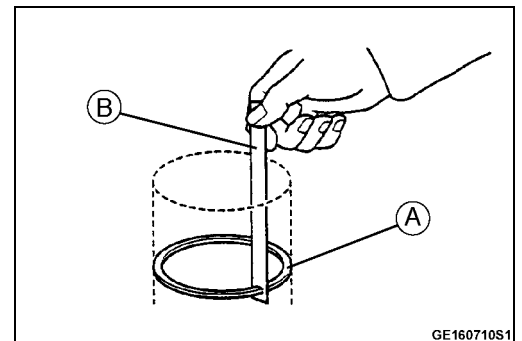
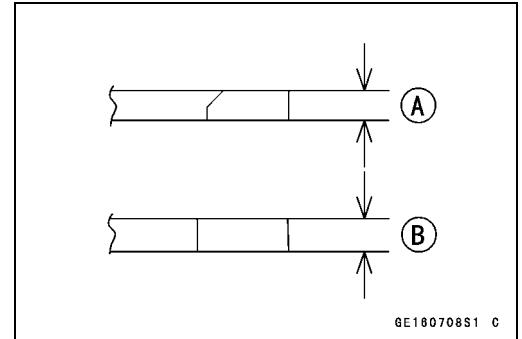

5-34 ENGINE TOP END

Throttle Body Holder

Throttle Body Holder Installation

- Install the throttle body holders with the holes [A] upward.
- Check to make sure that the O-ring is not damaged, and apply high-temperature grease to it.
- Install the clamps [B] as shown.
- Tighten the holder bolt.

Torque - Throttle Body Holder Bolts: 12 N·m (1.2 kgf·m, 106 in·lb)

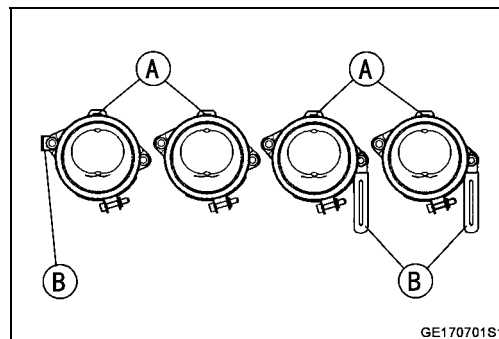

Muffler

⚠ WARNING

To avoid a serious burn, do not remove the muffler when the engine is still hot. Wait until the muffler cools down.

Muffler Removal

- Remove:
 - Lower Fairings with Lower Inner Fairing (see Frame chapter)
 - Lower Inner Covers (see Frame chapter)
 - Air Inlet Ducts (see Fuel System (DFI) chapter)
 - Radiator (see Cooling System chapter)
- Muffler Body Mounting Nut [A]

- Remove:
 - Exhaust Pipe Manifold Holder Nuts [A]
- Pull the muffler body mounting bolt and remove the muffler assembly.



Muffler Installation

- Replace the exhaust pipe gaskets with new ones.
- Thoroughly warm up the engine, wait until the engine cools down, and retighten all the bolts and nuts.

Muffler Body Removal

- Unscrew the muffler body connection cover bolts [A] and remove the cover [B].

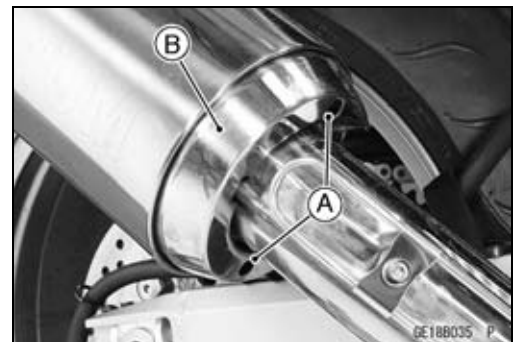

- Remove:
 - Muffler Body Connection Nuts [A]
 - Muffler Body Mounting Bolt and Nut [B]
- Pull the muffler body [C] backward.

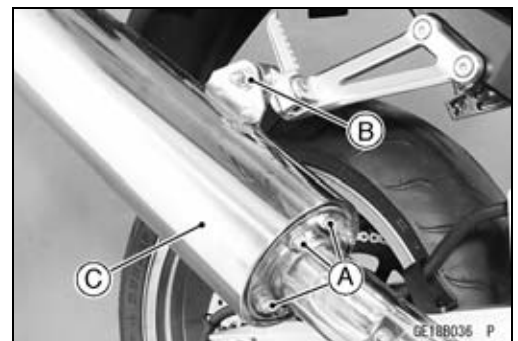

5-36 ENGINE TOP END

Muffler

Muffler Body Installation

- Replace the exhaust pipe connection gasket [A] with a new one.
- Insert the muffler body to the exhaust pipe end.
- Tighten:
 - Torque - Muffler Body Connection Nuts: 34 N·m (3.5 kgf·m, 25 ft·lb)**
- Tighten:
 - Muffler Body Connecting Cover Bolts
 - Muffler Body Mounting Bolt and Nut
- Thoroughly warm up the engine, wait until the engine cools down, and retighten all the bolts and nuts.



Clutch

Table of Contents

Exploded View	6-2
Specifications	6-3
Clutch Lever and Cable	6-4
Lever Free Play Inspection	6-4
Lever Free Play Adjustment.....	6-4
Cable Removal	6-4
Cable Installation	6-4
Cable Lubrication	6-4
Clutch Lever Installation.....	6-4
Clutch Cover.....	6-5
Clutch Cover Removal	6-5
Clutch Cover Installation	6-5
Release Shaft Removal	6-6
Release Shaft Installation	6-6
Clutch Cover Disassembly.....	6-6
Clutch Cover Assembly.....	6-7
Clutch	6-8
Clutch Removal.....	6-8
Clutch Installation.....	6-9
Clutch Plate Assembly Inspection.....	6-11
Clutch Plate Assembly Adjustment	6-11
Clutch Plate, Wear, Damage Inspection	6-12
Clutch Plate Warp Inspection.....	6-12
Clutch Spring Free Length Measurement.....	6-12

6-2 CLUTCH

Exploded View

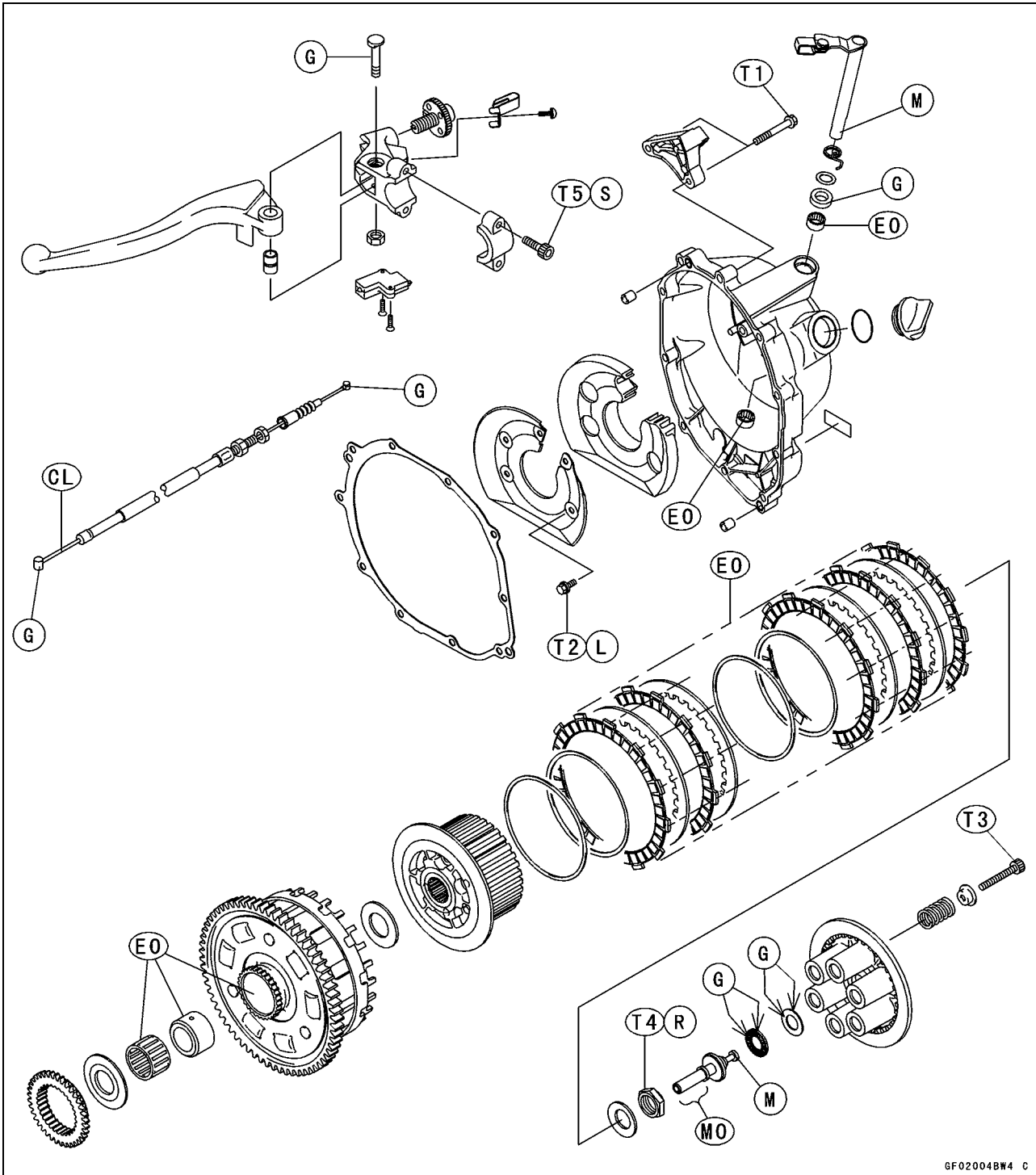

GF02004BW4 C

T1: 15 N·m (1.5 kgf·m, 11 ft·lb)

T2: 7.0 N·m (0.70 kgf·m, 62 in·lb)

T3: 8.8 N·m (0.90 kgf·m, 78 in·lb)

T4: 135 N·m (14 kgf·m, 100 ft·lb)

T5: 7.8 N·m (0.80 kgf·m, 69 in·lb)

CL: Apply cable lubricant.

EO: Apply engine oil.

G: Apply grease.

L: Apply a non-permanent locking agent.

M: Apply molybdenum disulfide grease.

MO: Apply molybdenum disulfide oil solution.

R: Replacement Parts

S: Follow the specific tightening sequence.

Specifications

Item	Standard	Service Limit
Clutch Lever Free Play	2 ~ 3 mm (0.08 ~ 0.12 in.)	— — —
Clutch		
Friction Plate Thickness	3.22 ~ 3.38 mm (0.127 ~ 0.133 in.)	3.0 mm (0.12 in.)
Friction and Steel Plate Warp	0.15 mm (0.0059 in.) or less	0.3 mm (0.01 in.)
Clutch Plate Assembly Length	56.8 ~ 57.6 mm (2.24 ~ 2.27 in.)	— — —
Clutch Spring Free Length	73.49 mm (2.893 in.)	68.5 mm (2.70 in.)

Special Tools - Clutch Holder: 57001-1243

Clutch Gear Setting: 57001-1455

Sealant - Kawasaki Bond (Silicone Sealant): 56019-120

6-4 CLUTCH

Clutch Lever and Cable

Lever Free Play Inspection

- Refer to the Clutch Adjust Inspection in the Periodic Maintenance chapter.

Lever Free Play Adjustment

- Refer to the Clutch Adjust Inspection in the Periodic Maintenance chapter.

Cable Removal

- Remove the right lower inner cover (see Frame chapter).
- Slide the dust cover [A] at the clutch cable lower end out of place.
- Loosen the nuts [B], and slide the outer of the clutch cable to the lower side.

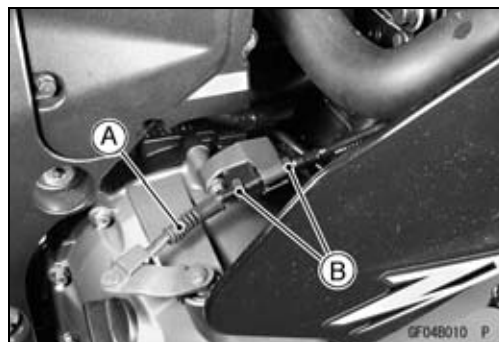

- Screw in the adjuster.
- Line up the slots [A] in the clutch lever [B] and adjuster [C], and then free the cable from the lever.
- While pushing the stopper [E], turn the adjuster.
- Free the clutch inner cable tip from the clutch release lever.
- Push the release lever toward the front of the motorcycle and tape the release lever to the clutch cover to prevent the release shaft from falling out.
- Pull the clutch cable out of the frame.

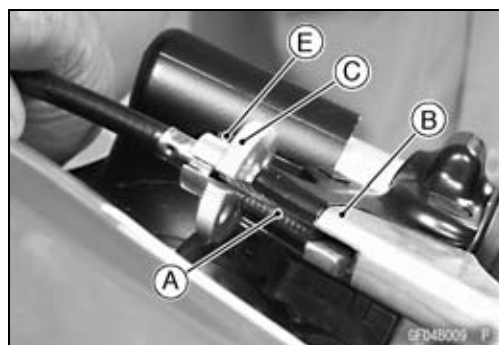

Cable Installation

- Run the clutch cable correctly (see General Information chapter).
- Adjust the clutch cable (see Clutch Adjust Inspection in the Periodic Maintenance chapter).

Cable Lubrication

- Refer to the General Lubrication in the Periodic Maintenance chapter.

Clutch Lever Installation

- Install the clutch lever [A] so that the mating surface [B] of the switch housing is aligned with the mating surface [C] of the clutch lever clamp.
- Tighten the upper clamp bolt first, and then the lower clamp bolt. There will be a gap at the lower part of the clamp after tightening.

Torque - Clutch Lever Clamp Bolts: 7.8 N·m (0.80 kgf·m, 69 in·lb)

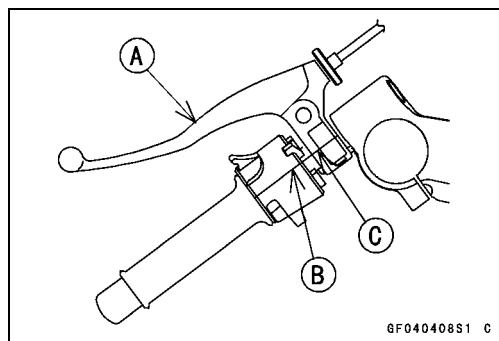

Clutch Cover

Clutch Cover Removal

- Set the motorcycle on its side stand, squeeze the front brake lever, and hold it with a band [A] to prevent the motorcycle from running forward.

⚠ WARNING

Be sure to hold the front brake when removing the clutch, or the motorcycle may fall over. It could cause an accident and injury.

CAUTION

Be sure to hold the front brake when removing the clutch, or the motorcycle may fall over. The motorcycle could be damaged.

- Remove:
 - Right Lower Fairing (see Frame chapter)
 - Clutch Cover Mounting Bolts [B]
 - Clutch Cable Bracket [C]
 - Clutch Cable Lower End [A]

- Turn the release lever [B] toward the rear [C] as shown, and remove the clutch cover [A].

CAUTION

Do not remove the clutch release lever and shaft assembly unless it is absolutely necessary. If removed, the oil seal replacement may be required.

Clutch Cover Installation

- Apply silicone sealant to the area [A] where the mating surface of the crankcase touches the clutch cover gasket.
- Be sure to install the pins [B].

Sealant - Kawasaki Bond (Silicone Sealant): 56019-120

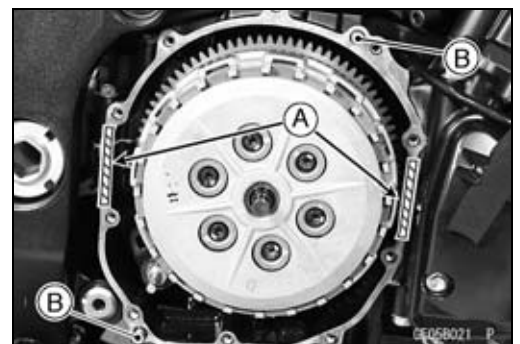
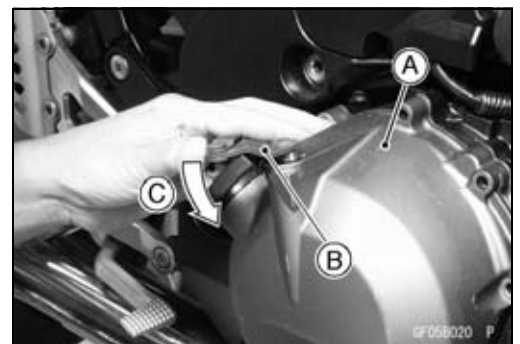
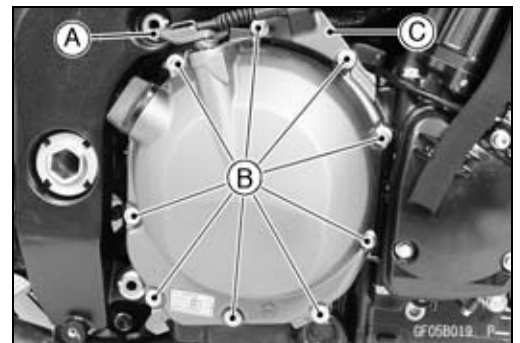

6-6 CLUTCH

Clutch Cover

- Replace the cover gasket with a new one.
- Apply a non-permanent locking agent to the two cover bolts [A] only.
- Tighten the cover bolts.

Torque - Clutch Cover Bolts: 15 N·m (1.5 kgf·m, 11 ft·lb)

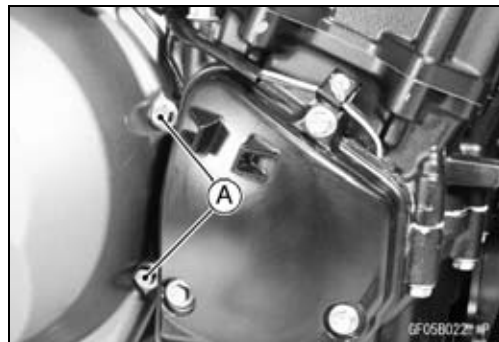

Release Shaft Removal

- Remove the clutch cable lower end (see Clutch Cable Removal).
- Turn the release lever [A] toward the right about 45° [B] and pull the lever and shaft assembly straight out of the clutch cover.

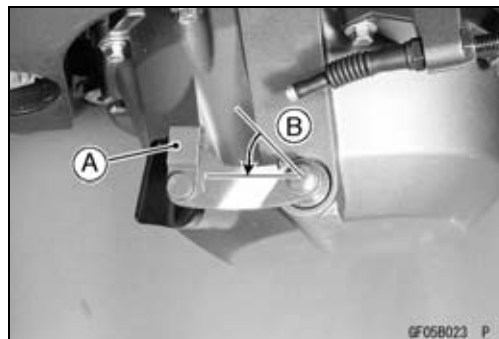

Release Shaft Installation

- Apply oil to the needle bearings in the hole of the clutch cover.
- Apply high-temperature grease to the oil seal lips of the clutch cover.
- Apply molybdenum disulfide grease to the pusher-holding portion on the release shaft.
- Insert the release shaft [A] straight into the upper hole of the clutch cover.
 - Spring [B]
 - Washer [C]

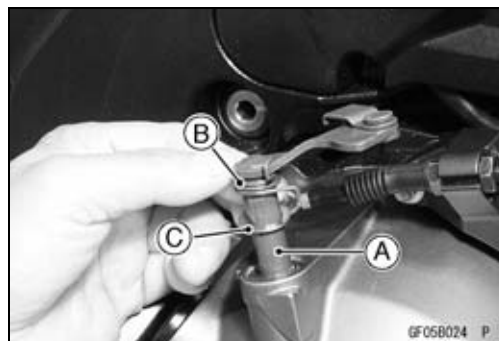

CAUTION

When inserting the release shaft, be careful not to remove the spring of the oil seal.

Clutch Cover Disassembly

- Remove the clutch cover (see Clutch Cover Removal).
- Pull out the release shaft (see Release Shaft Removal).
- Remove:
 - Damper Plate Bolts [A]
 - Damper Plate [B]
 - Damper

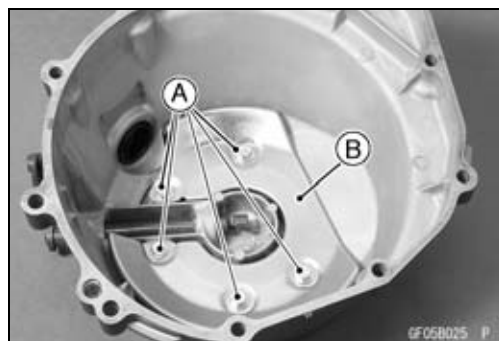

Clutch Cover

- Remove:
 - Oil Seal [A]
 - Needle Bearings [B]

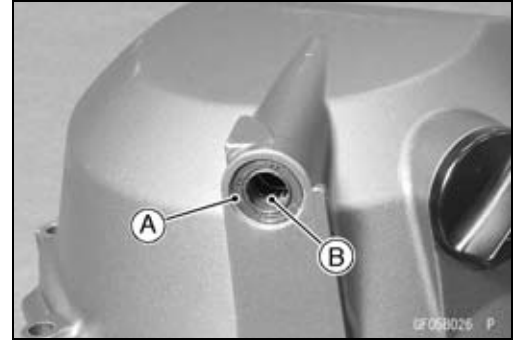

Clutch Cover Assembly

- Replace the needle bearings and oil seal with new one.

NOTE

- Install the needle bearings so that the manufacturer's mark face out.
- Install the needle bearings [A] and oil seal [B] position as shown.

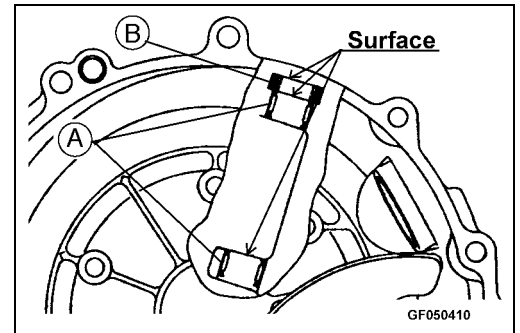

- Apply a non-permanent locking agent to the damper plate bolts and tighten them.
- Confirm that the torque to fast tightened bolt.

Torque - Clutch Cover Damper Plate Bolts: 7.0 N·m (0.70 kgf·m, 62 in·lb)

6-8 CLUTCH

Clutch

Clutch Removal

- Remove:
 - Right Lower Fairing (see Frame chapter)
 - Clutch Cover (see Clutch Cover Removal)
 - Clutch Spring Bolts [A]
 - Clutch Springs
 - Clutch Spring Plate [B] (with thrust bearing, pusher [C] and washer)

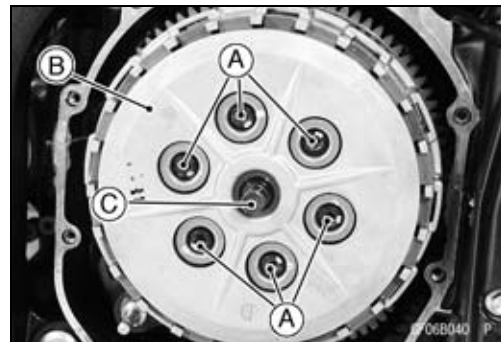

- Remove:
 - Friction Plates [A]
 - Steel Plates
 - Springs
 - Spring Seats



- Holding the clutch hub [A], remove the nut [B] and washer [C]

Special Tool - Clutch Holder: 57001-1243 [D]

- Remove:
 - Clutch Hub

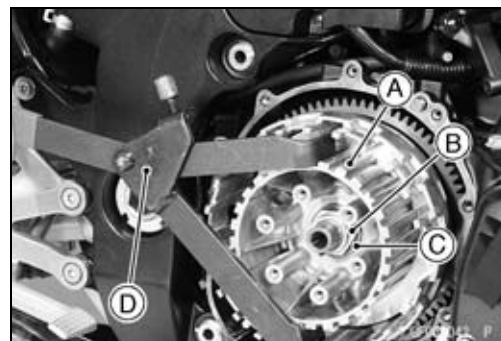

- Insert the clutch gear setting [A] to the hole of the clutch housing.
- Position the hole [B] of the clutch housing at the front side of the engine so that the tip of the gear setting does not hit the crankcase wall.
- Align the teeth of the clutch housing gears by the gear setting.

Special Tool - Clutch Gear Setting: 57001-1455

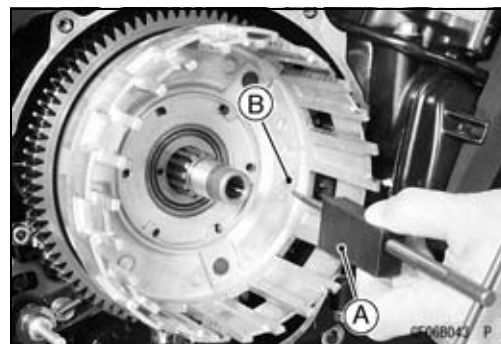

- Pull out the sleeve [A] from the clutch housing [B], and remove the housing.
- If the sleeve does not pull out easily, insert M4 bolts [C] into the threaded hole of the sleeve, and pull out the sleeve.
- Remove the thrust washer.



Clutch

Clutch Installation

- Install the thrust washer [A] by facing its chamfered side [B] towards the crankcase.

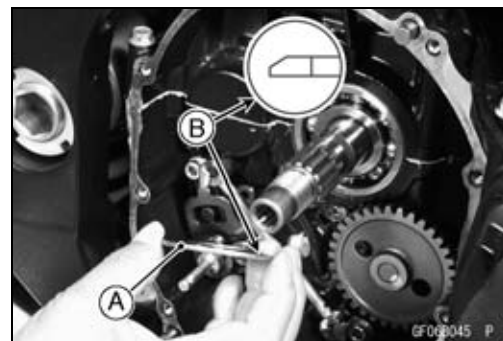

- Install the oil pump drive gear [A] on the clutch housing.



- Align the teeth of the clutch housing gears by the gear setting [A].
- Install the clutch housing so that the hole position forward of the engine.

Special Tool - Clutch Gear Setting: 57001-1455

- Install:
 - Clutch Housing
 - Needle Bearing
 - Sleeve

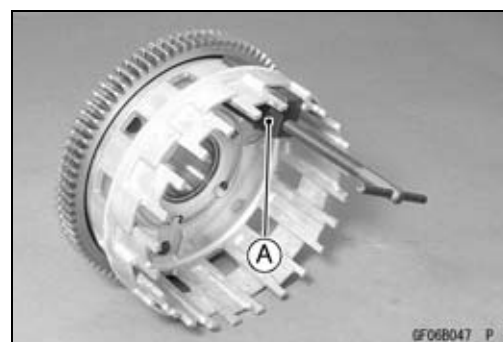

- Apply engine oil to the needle bearing and the sleeve before installation.

- Install the washer [A] so that the OUT SIDE mark [B] faces outward.

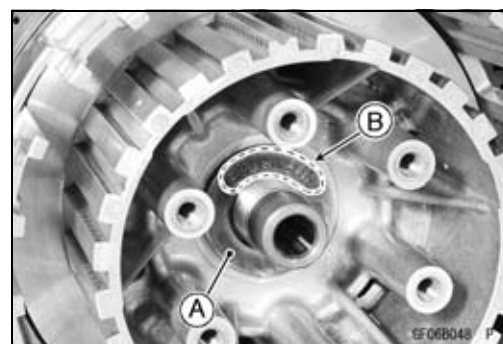

- Replace the clutch hub nut with a new one.
- Holding the clutch hub, tighten the clutch hub nut with the torque wrench [B].

Special Tool - Clutch Holder [A]: 57001-1243

Torque - Clutch Hub Nut: 135 N·m (14 kgf·m, 100 ft·lb)

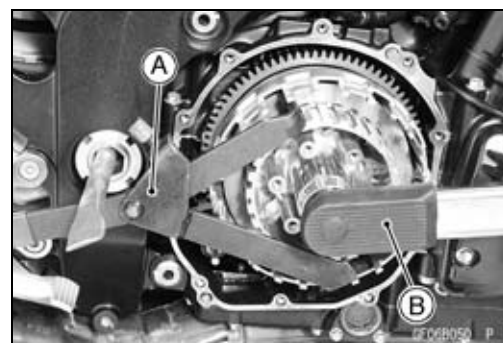

6-10 CLUTCH

Clutch

- Install the spring seats [D] [F], springs [E], friction plates [A] [C] [H] and steel plates [B] as shown.

NOTE

- The inside diameter of first and seventh friction plates are larger than the others because the spring seats and springs are equipped to decrease the judder noise as shown.

Clutch Hub [G]

CAUTION

If new dry friction plates and steel plates are installed, apply engine oil to the surfaces of each plate to avoid clutch plate seizure.

- Install outer-end friction plate, that has the narrowest groove [A] among others.

- Install the last friction plate [A] fitting the tangs in the grooves in the housing as shown.

- Apply molybdenum disulfide oil solution [MO] to the outside surface of the pusher [A], then install the pusher into the drive shaft.
- Apply high-temperature grease [G] to both side of needle bearing [B] and washer [C], then install them onto the pusher.
- Apply molybdenum disulfide grease [M] to the mating surface of the pusher.

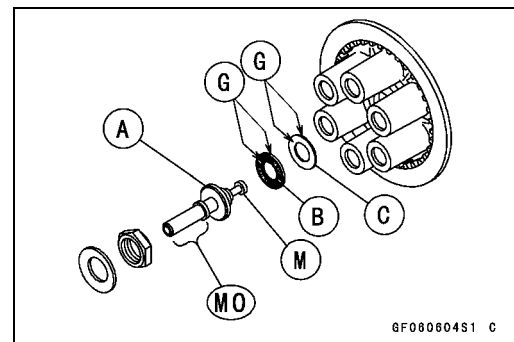
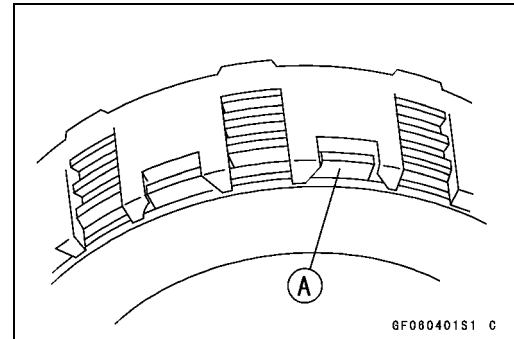
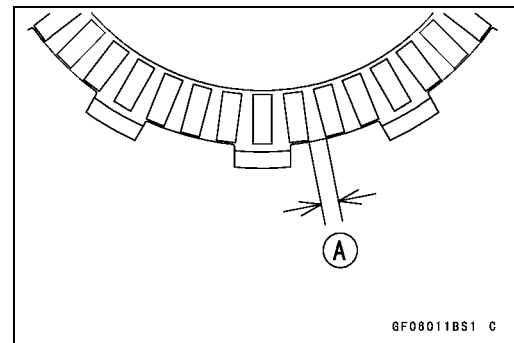
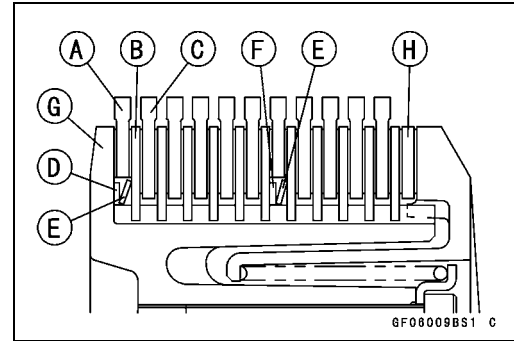

Clutch

- Align the mark [A] of the spring plate [B] to one of the grooves [C] of the clutch hub [D] to install the spring plate on the clutch hub.
- Install the spring, and tighten the clutch spring bolts evenly.

Torque - Clutch Spring Bolts: 8.8 N·m (0.90 kgf·m, 78 in·lb)

- Install the clutch cover (see Clutch Cover Installation).

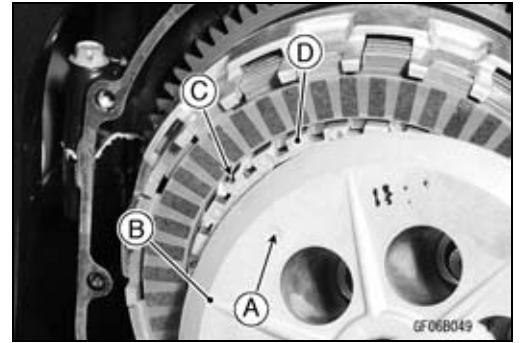

Clutch Plate Assembly Inspection

- Inspect the friction plate thickness (see Clutch Plate, Wear, Damage Inspection).
- Measure the length [A] of the clutch plate assembly as shown.

○Assemble:

- Clutch Hub [B]
- Spring Seats [C] [K]
- Springs [D]
- Friction Plates [E] [L] [M]
- Steel Plates [F]
- Spring Plate [G]
- Springs [H]
- Spring Seats [I]
- Spring Bolts [J]

Torque - Clutch Spring Bolts: 8.8 N·m (0.90 kgf·m, 78 in·lb)

Clutch Plate Assembly Length

Standard: 56.8 ~ 57.6 mm (2.24 ~ 2.27 in.)

- ★If the length is not within the specified range, adjust the length (see Clutch Plate Assembly Adjustment).

Clutch Plate Assembly Adjustment

- Inspect the clutch plate assembly length, and then replace the steel plate(s) which brings the length within the specified range.

○Remove:

- Spring Bolts
- Springs
- Spring Holders
- Spring Plate
- Clutch Plates

○Replace the following steel plate(s).

Part Number	Thickness
13089-1125	1.4 mm (0.055 in.)
13089-1123	1.6 mm (0.063 in.) (Standard)
13089-1124	2.0 mm (0.079 in.)

NOTE

○Do not use the steel plate of 2.0 mm (0.079 in.) and 1.4 mm (0.055 in.) thickness at the same time.

- Install the removed parts, and inspect the clutch plate assembly length.

Torque - Clutch Spring Bolts: 8.8 N·m (0.90 kgf·m, 78 in·lb)

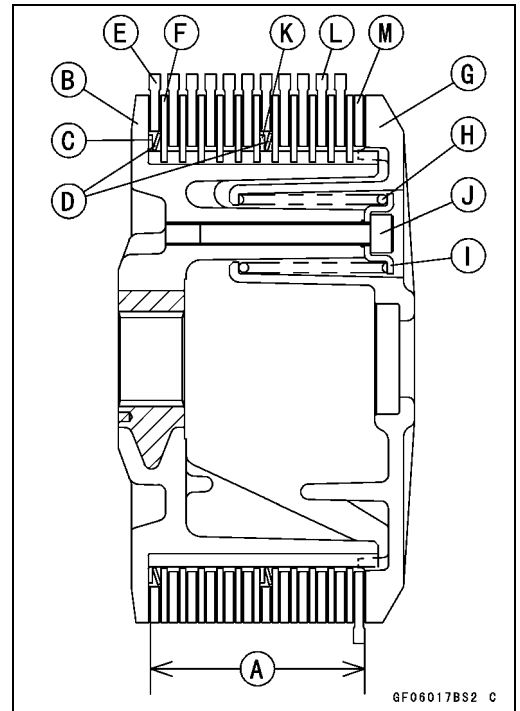

6-12 CLUTCH

Clutch

Clutch Plate, Wear, Damage Inspection

- Visually inspect the friction and steel plates for signs of seizure, overheating (discoloration), or uneven wear.
- Measure the thickness of the friction plate [A] at several points.
- ★ If any plates show signs of damage, or if they have worn past the service limit, replace them with new ones.

Friction Plate Thickness

Standard: 3.22 ~ 3.38 mm (0.127 ~ 0.133 in.)

Service Limit: 3.0 mm (0.12 in.)

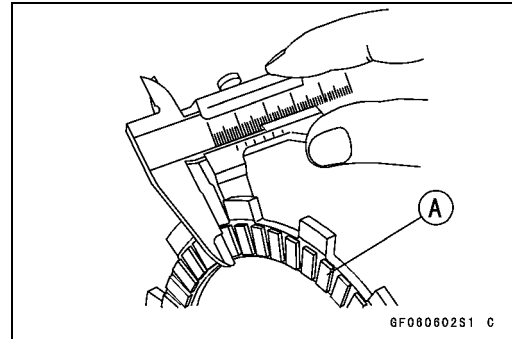

Clutch Plate Warp Inspection

- Place each friction plate or steel plate on a surface plate and measure the gap between the surface plate [A] and each friction plate or steel plate [B] with a thickness gauge [C]. The gap is the amount of friction or steel plate warp.
- ★ If any plate is warped over the service limit, replace it with a new one.

Friction and Steel Plate Warp

Standard: 0.15 mm (0.0059 in.) or less

Service Limit: 0.3 mm (0.01 in.)

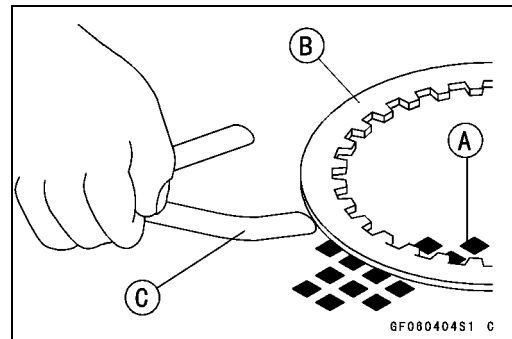

Clutch Spring Free Length Measurement

- Measure the free length [A] of the clutch springs.
- ★ If any spring is shorter than the service limit, it must be replaced.

Clutch Spring Free Length

Standard: 73.49 mm (2.893 in.)

Service Limit: 68.5 mm (2.70 in.)

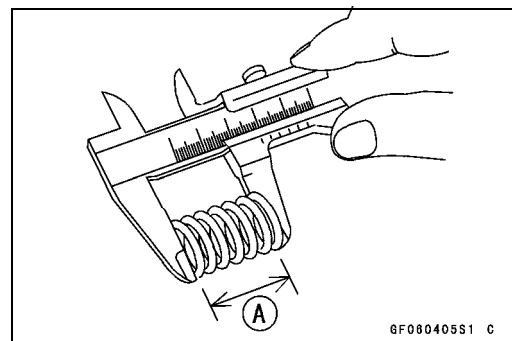

Engine Lubrication System

Table of Contents

Exploded View.....	7-2
Engine Oil Flow Chart.....	7-3
Specifications	7-4
Engine Oil and Oil Filter.....	7-5
Oil Level Inspection.....	7-5
Engine Oil Change.....	7-5
Oil Filter Replacement	7-5
Oil Cooler.....	7-6
Oil Cooler Removal.....	7-6
Oil Cooler Installation.....	7-6
Oil Pan.....	7-7
Oil Pan Removal	7-7
Oil Pan Installation.....	7-7
Oil Pump, Oil Pump Drive Gear and Oil Pressure Relief Valve.....	7-9
Oil Pump Removal.....	7-9
Oil Pump Installation	7-9
Oil Pump Inspection.....	7-9
Oil Pump Drive Gear Removal.....	7-10
Oil Pump Drive Gear Installation.....	7-10
Oil Pressure Relief Valve Inspection.....	7-10
Oil Pressure Measurement.....	7-12
Oil Pressure Measurement	7-12
Oil Pressure Switch	7-13
Oil Pressure Switch Removal	7-13
Oil Pressure Switch Installation	7-13

7-2 ENGINE LUBRICATION SYSTEM

Exploded View

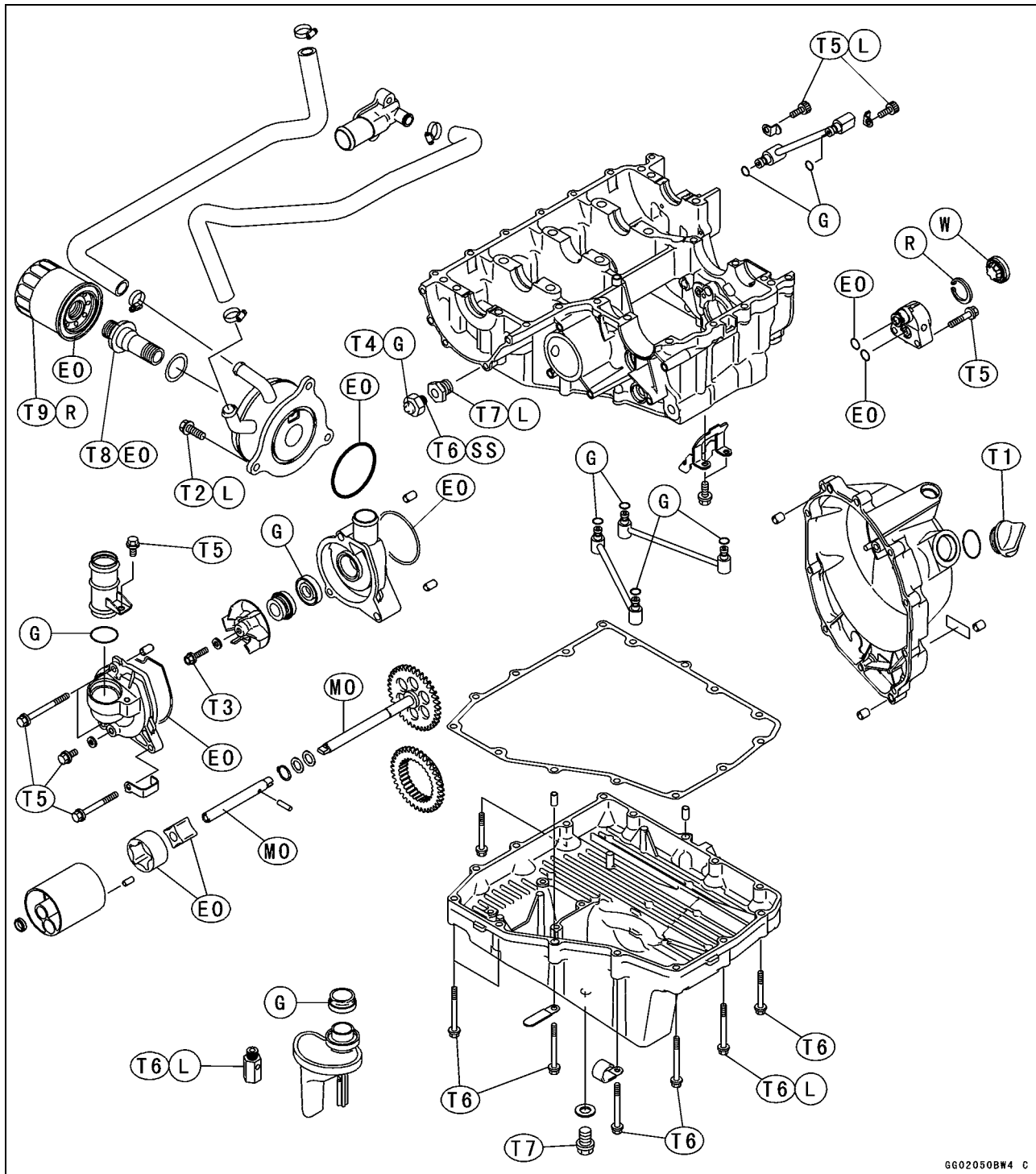

GG02050B#4 C

T1: 1.5 N·m (0.15 kgf·m, 13 in·lb) or Hand
-Tight

T2: 25 N·m (2.5 kgf·m, 18 ft·lb)

T3: 10 N·m (1.0 kgf·m, 89 in·lb)

T4: 1.5 N·m (0.15 kgf·m, 13 in·lb)

T5: 12 N·m (1.2 kgf·m, 106 in·lb)

T6: 15 N·m (1.5 kgf·m, 11 ft·lb)

T7: 20 N·m (2.0 kgf·m, 15 ft·lb)

T8: 78 N·m (7.8 kgf·m, 58 ft·lb)

T9: 31 N·m (3.2 kgf·m, 23 ft·lb)

EO: Apply engine oil.

G: Apply grease.

L: Apply a non-permanent locking agent.

MO: Apply molybdenum disulfide oil solution.

R: Replacement Parts

SS: Apply silicone sealant.

W: Apply water.

Engine Oil Flow Chart

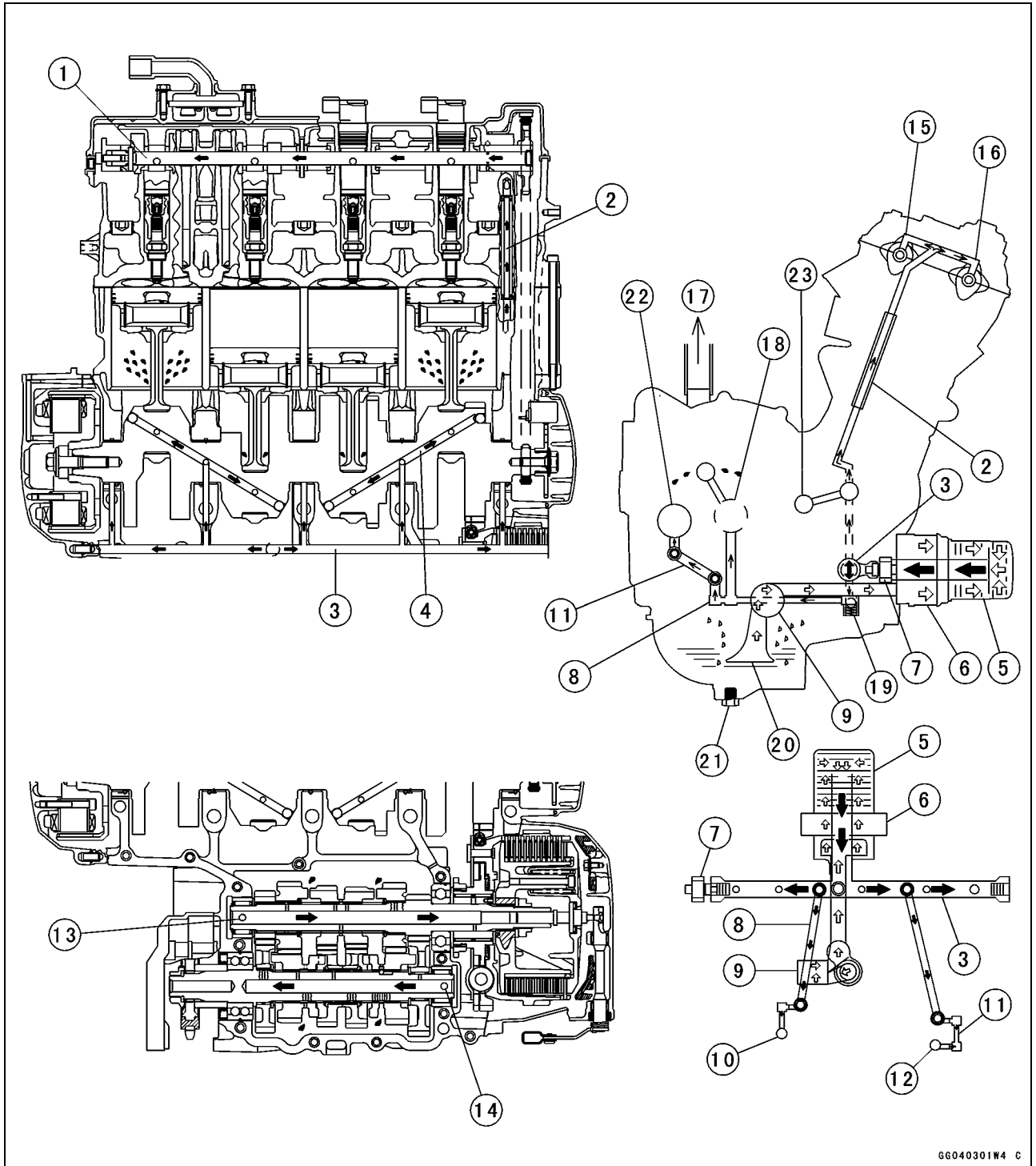

66040301W4 C

- | | |
|---------------------------|-----------------------------------|
| 1. Camshaft Oil Passage | 13. Drive Shaft Oil Passage Hole |
| 2. Oil Pipe | 14. Output Shaft Oil Passage Hole |
| 3. Main Oil Passage | 15. Inlet Camshaft |
| 4. Crankshaft Oil Passage | 16. Exhaust Camshaft |
| 5. Oil Filter | 17. To Air Cleaner |
| 6. Oil Cooler | 18. Drive Shaft |
| 7. Oil Pressure Switch | 19. Relief Valve |
| 8. Oil Pipe | 20. Oil Screen |
| 9. Oil Pump | 21. Oil Drain Plug |
| 10. To Drive Shaft | 22. Output Shaft |
| 11. Oil Pipe | 23. Stater Clutch |
| 12. To Output Shaft | |

7-4 ENGINE LUBRICATION SYSTEM

Specifications

Item	Standard
Engine Oil	
Grade	API SE, SF, or SG API SH or SJ with JASO MA
Viscosity	SAE 10W-40
Capacity	2.5 L (2.6 US qt, when filter is not removed) 2.8 L (3.0 US qt, when filter is removed) 3.6 L (3.8 US qt, when engine is completely dry)
Level	Between upper and lower level lines
Oil Pressure Measurement	
Oil Pressure @4 000 r/min (rpm), Oil Temperature 90°C (194°F)	196 kPa (2.0 kgf/cm ² , 28 psi)

Special Tools - Outside Circlip Pliers: 57001-144

Oil Pressure Gauge, 10 kgf/cm²: 57001-164

Oil Pressure Gauge Adapter, PT 1/8: 57001-1033

Oil Filter Wrench: 57001-1249

Sealant - Kawasaki Bond (Silicone Sealant): 56019-120

Engine Oil and Oil Filter

⚠ WARNING

Motorcycle operation with insufficient, deteriorated, or contaminated engine oil will cause accelerated wear and may result in engine or transmission seizure, accident, and injury.

Oil Level Inspection

- Check that the engine oil level is between the upper [A] and lower [B] levels in the gauge.
- Situate the motorcycle so that it is perpendicular to the ground.

NOTE

- If the motorcycle has just been used, wait several minutes for all the oil to drain down.
- If the oil has just been changed, start the engine and run it for several minutes at idle speed. This fills the oil filter with oil. Stop the engine, then wait several minutes until the oil settles.

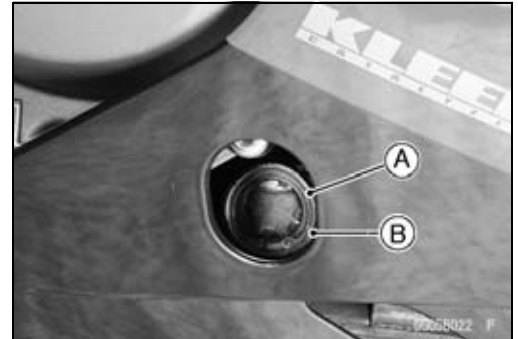

CAUTION

Racing the engine before the oil reaches every part can cause engine seizure.

If the engine oil gets extremely low or if the oil pump or oil passages clog up or otherwise do not function properly, the oil pressure warning light will light. If this light stays on when the engine is running above idle speed, stop the engine immediately and find the cause.

- ★ If the oil level is too high, remove the excess oil, using a syringe or some other suitable device.
- ★ If the oil level is too low, add the correct amount of oil through the oil filter opening. Use the same type and make of oil that is already in the engine.

NOTE

- If the engine oil type and make are unknown, use any brand of the specified oil to top off the level in preference to running the engine with the oil level low. Then at your earliest convenience, change the oil completely.

Engine Oil Change

- Refer to the Engine Oil Change in the Periodic Maintenance chapter.

Oil Filter Replacement

- Refer to the Oil Filter Replacement in the Periodic Maintenance chapter.

7-6 ENGINE LUBRICATION SYSTEM

Oil Cooler

Oil Cooler Removal

- Remove:
 - Left Lower Fairing (see Frame chapter)
- Drain:
 - Engine Oil (see Engine Oil Change in the Periodic Maintenance chapter)
 - Coolant (see Coolant Change in the Periodic Maintenance chapter)
- Loosen the clamp screws [A] and remove the oil cooler water hoses [B] from the oil cooler.
- Remove the oil filter (see Oil Filter Replace in the Periodic Maintenance chapter).
- Unscrew the oil cooler mounting bolts [A] and oil cooler passage bolt [B] from the crankcase.
- Remove the oil cooler.
- Drain the coolant and engine oil remaining in the oil cooler into a suitable container.

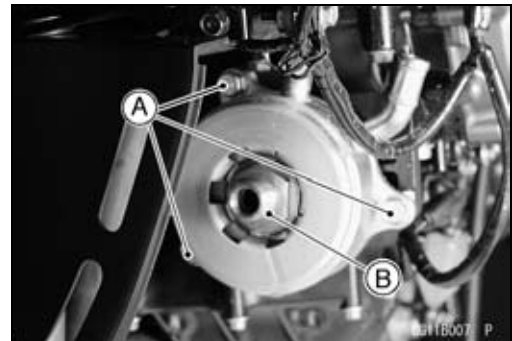
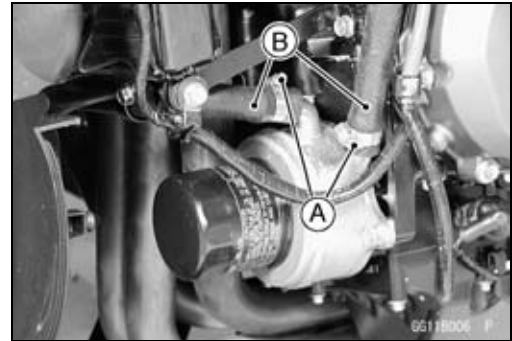

Oil Cooler Installation

- Installation is the reverse of removal. Note the following.
- Apply engine oil to the O-ring [A] before installation.



- Apply engine oil to the oil cooler passage bolt.
- Apply a non-permanent locking agent to the oil cooler mounting bolts and install the oil cooler temporarily with the bolt.
- Install the oil cooler mounting bolts evenly.
- Tighten the oil cooler passage bolt [A].

Torque - Oil Cooler Passage Bolt: 78 N·m (7.8 kgf·m, 58 ft·lb)

- Tighten the oil cooler mounting bolts [B].

Torque - Oil Cooler Mounting Bolts: 25 N·m (2.5 kgf·m, 18 ft·lb)

- Pour:
 - Engine Oil (see Engine Oil Change in the Periodic Maintenance chapter)
 - Coolant (see Coolant Change in the Periodic Maintenance chapter)

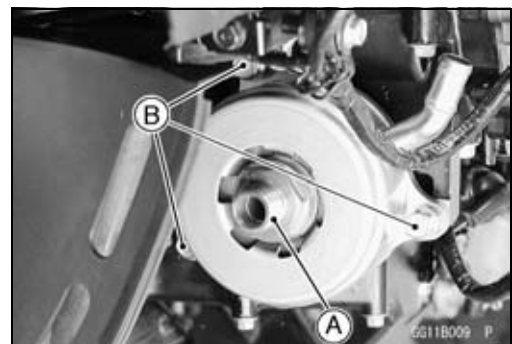

Oil Pan

Oil Pan Removal

- Remove:
 - Engine Oil (drain, see Engine Oil Change in the Periodic Maintenance chapter)
 - Muffler (see Engine Top End chapter)
- Unscrew the oil level gauge bolts [A] and pull out the level gauge [B].
- Unscrew the oil pan bolts [C] and remove the oil pan [D].

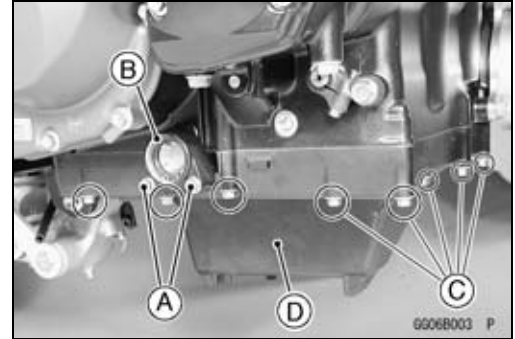

- Remove the oil pipes [A], oil pressure relief valve [B] and oil screen [C] as necessary.

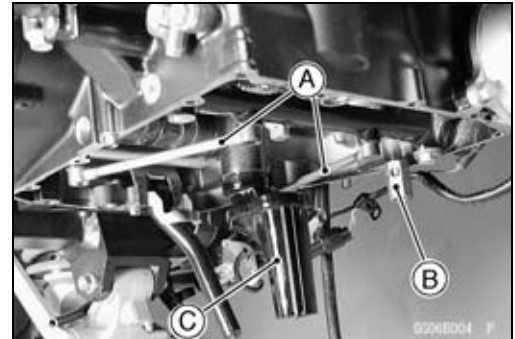

Oil Pan Installation

- Clean the oil screen [A] with high-flash point solvent and remove any particles stuck to it.

⚠ WARNING

Clean the screen in a well-ventilated area, and take care that there is no spark or flame anywhere near the working area. Because of the danger of highly flammable liquids, do not use gasoline or low-flash point solvents.



NOTE

- While cleaning the screen, check for any metal particles that might indicate internal engine damage.
 - Check the screen carefully for any damage: hole and broken wires.
- ★ If the screen is damaged, replace it.
- Apply grease to the O-ring on the oil screen.
 - Install the oil screen so that the crankcase rib [A] fits the slot [B] of the oil screen.

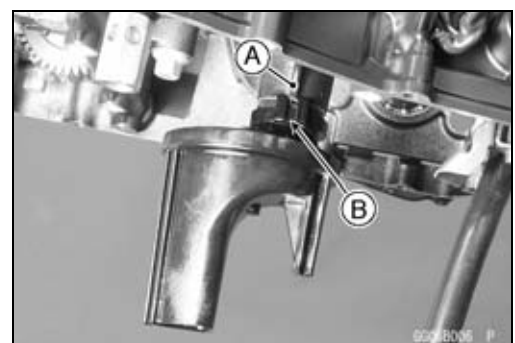

7-8 ENGINE LUBRICATION SYSTEM

Oil Pan

- Apply grease to the O-rings on the oil pipes [C].
- Apply a non-permanent locking agent to the threads of the oil pressure relief valve [D], and tighten it.

Torque - Oil Pressure Relief Valve: 15 N·m (1.5 kgf·m, 11 ft·lb)

- Replace the oil pan gasket with a new one.
- Check that the pins [E] are in place.

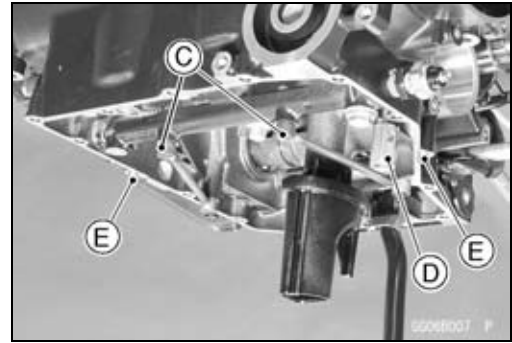

- Tighten the oil pan bolts.
- Install two dowel pins to mark [A], two clamps to mark [B], and two bolts, shorter than others, to mark [C].
- Apply a non-permanent locking agent to the threads of the bolt [D].

Torque - Oil Pan Bolts: 15 N·m (1.5 kgf·m, 11 ft·lb)

- Apply engine oil to the O-rings on the oil level gauge, and tighten it.

Torque - Oil Level Gauge Bolts: 12 N·m (1.2 kgf·m, 106 in·lb)

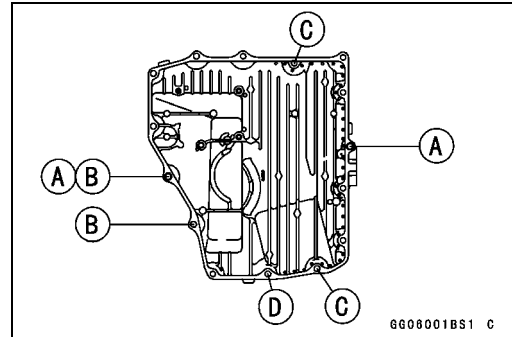

Oil Pump, Oil Pump Drive Gear and Oil Pressure Relief Valve

Oil Pump Removal

- Drain:
 - Engine Oil (see Engine Oil Change in the Periodic Maintenance chapter)
 - Coolant (see Coolant Change in the Periodic Maintenance chapter)
- Remove:
 - Left Lower Fairing (see Frame chapter)
 - Water Pump Cover (see Cooling System chapter)
 - Impeller (see Cooling System chapter)
 - Water Pump Housing (see Cooling System chapter)
- Pull out the oil pump cover [A].
- Pull out the oil (water) pump shaft [B] with inner rotor.
- Remove the outer rotor.

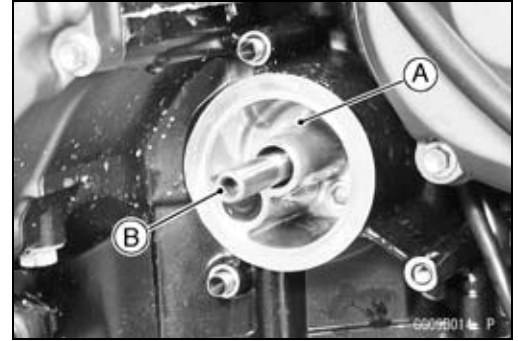

Oil Pump Installation

- Assemble the pin [A], inner rotor [B] onto the oil (water) pump shaft [C].
- Fit the pin into the slot [D] of the inner rotor.

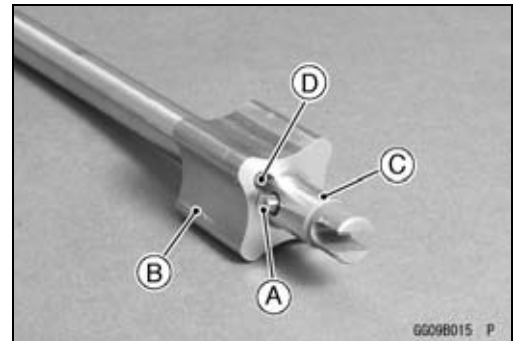

- Install the outer rotor [A] into the crankcase.
- Apply molybdenum disulfide oil solution to the journal positions (3 places) on the shaft.
- Insert the shaft assembly [B].
- Turn the pump shaft so that the slot [C] on its shaft fits onto the projection [D] of the pump drive gear shaft.

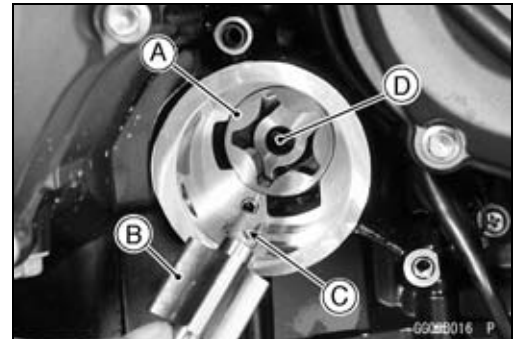

- Fit the oil pump cover [B] aligning its hole [C] to the pin [A] installed on the crankcase.

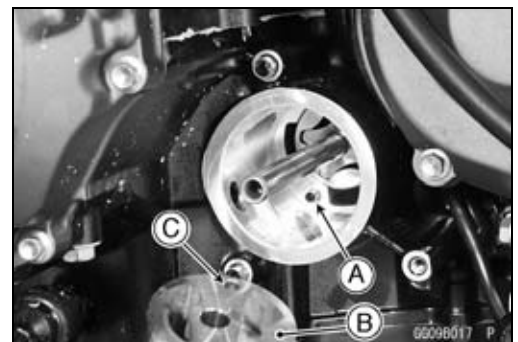

- Install:
 - Water Pump Housing (see Cooling System chapter)
 - Impeller (see Cooling System chapter)
 - Water Pump Cover (see Cooling System chapter)

Oil Pump Inspection

- Remove the oil pump parts.
- Visually inspect the oil pump outer and inner rotors and cover.
- ★ If there is any damage or uneven wear, replace the rotors and cover.

7-10 ENGINE LUBRICATION SYSTEM

Oil Pump, Oil Pump Drive Gear and Oil Pressure Relief Valve

Oil Pump Drive Gear Removal

- Remove:
 - Clutch (see Clutch chapter)
 - Oil Pan (see Oil Pan Removal)
 - Circlip [A] and Washer [B]

Special Tool - Outside Circlip Pliers: 57001-144

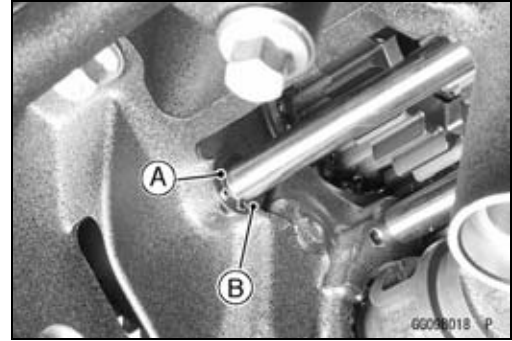

- Pull the oil pump drive gear [A] outside.



Oil Pump Drive Gear Installation

- Apply molybdenum disulfide oil solution to the journal position on the oil pump gear shaft.
- Install the circlip [A] into the groove [B] of the oil pump drive gear shaft.

Special Tool - Outside Circlip Pliers: 57001-144

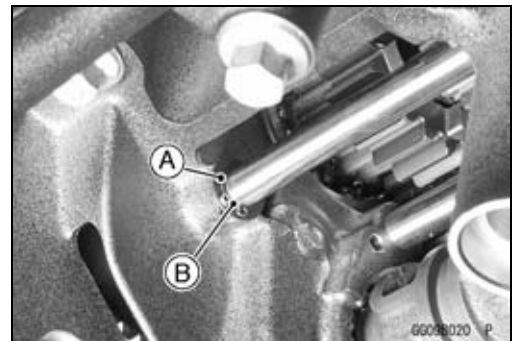

Oil Pressure Relief Valve Inspection

- Remove:
 - Oil Pan (see Oil Pan Removal)
 - Relief Valve [A]



Oil Pump, Oil Pump Drive Gear and Oil Pressure Relief Valve

- Check to see if the valve [A] slides smoothly when pushing it in with a wooden or other soft rod, and see if it comes back to its seat by spring [B] pressure.

NOTE

○ *Inspect the valve in its assembled state. Disassembly and assembly may change the valve performance.*

- ★ If any rough spots are found during above inspection, wash the valve clean with a high-flash point solvent and blow out any foreign particles that may be in the valve with compressed air.

⚠ WARNING

Clean the relief valve in a well-ventilated area, and take care that there is no spark or flame anywhere near the working area. Because of the danger of highly flammable liquids, do not use gasoline or low-flash point solvent.

- ★ If cleaning does not solve the problem, replace the relief valve as an assembly. The relief valve is precision made with no allowance for replacement of individual parts.

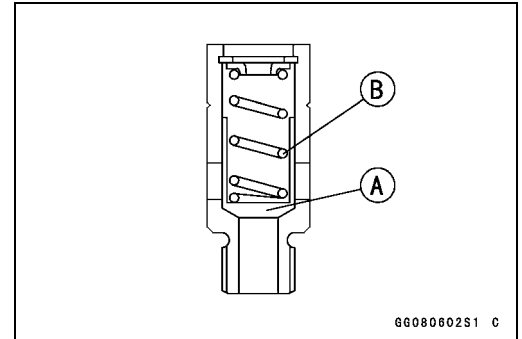

7-12 ENGINE LUBRICATION SYSTEM

Oil Pressure Measurement

Oil Pressure Measurement

- Remove the lower fairing (see Frame chapter).
- Remove the oil pressure switch, and attach the gauge and adapter to the plug hole.

Special Tools - Oil Pressure Gauge, 10 kgf/cm²: 57001-164 [A]

Oil Pressure Gauge Adapter, PT 1/8: 57001-1033 [B]

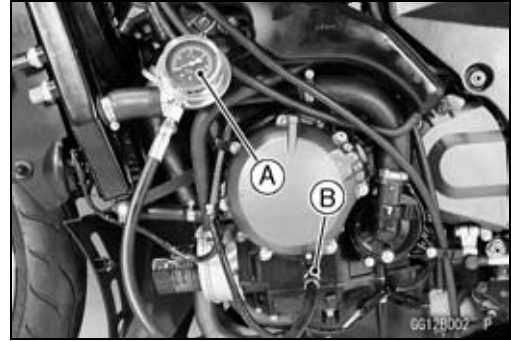

- Run the engine at the specified speed, and read the oil pressure gauge.
- ★ If the oil pressure is significantly below the specification, inspect the oil pump and relief valve.
- ★ If the oil pump and relief valve are not at fault, inspect the rest of the lubrication system.

Oil Pressure

Standard: 196 kPa (2.0 kgf/cm², 28 psi) @4 000 r/min (rpm), oil temperature 90°C (194°F)

- Stop the engine.
- Remove the oil pressure gauge and adapter.

⚠ WARNING

Take care against burns from hot engine oil that will drain through the oil passage when the gauge adapter is removed.

- Install the oil pressure switch (see Oil Pressure Switch Installation).

Oil Pressure Switch

Oil Pressure Switch Removal

- Remove:
 - Left Lower Fairing (see Frame chapter)
 - Engine Oil (drain, see Engine Oil Change in the Periodic Maintenance chapter)
 - Switch Cover [A]
 - Switch Terminal Bolt [B]
 - Oil Pressure Switch [C]

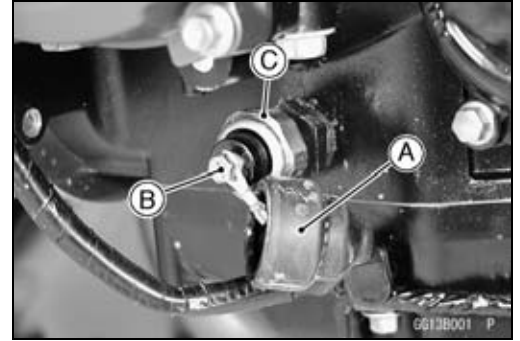

Oil Pressure Switch Installation

- Apply silicone sealant to the threads of the oil pressure switch and tighten it.
 - Sealant - Kawasaki Bond (Silicone Sealant): 56019-120**
 - Torque - Oil Pressure Switch: 15 N·m (1.5 kgf·m, 11 ft·lb)**
- Install the switch lead direction [A] forward and upward.
- Tighten the terminal bolt.
 - Torque - Oil Pressure Switch Terminal Bolt: 1.5 N·m (0.15 kgf·m, 13 in·lb)**
- Apply high-temperature grease to the terminal.



Engine Removal/Installation

Table of Contents

Exploded View.....	8-2
Engine Removal/Installation.....	8-3
Engine Removal.....	8-3
Engine Installation.....	8-5

8-2 ENGINE REMOVAL/INSTALLATION

Exploded View

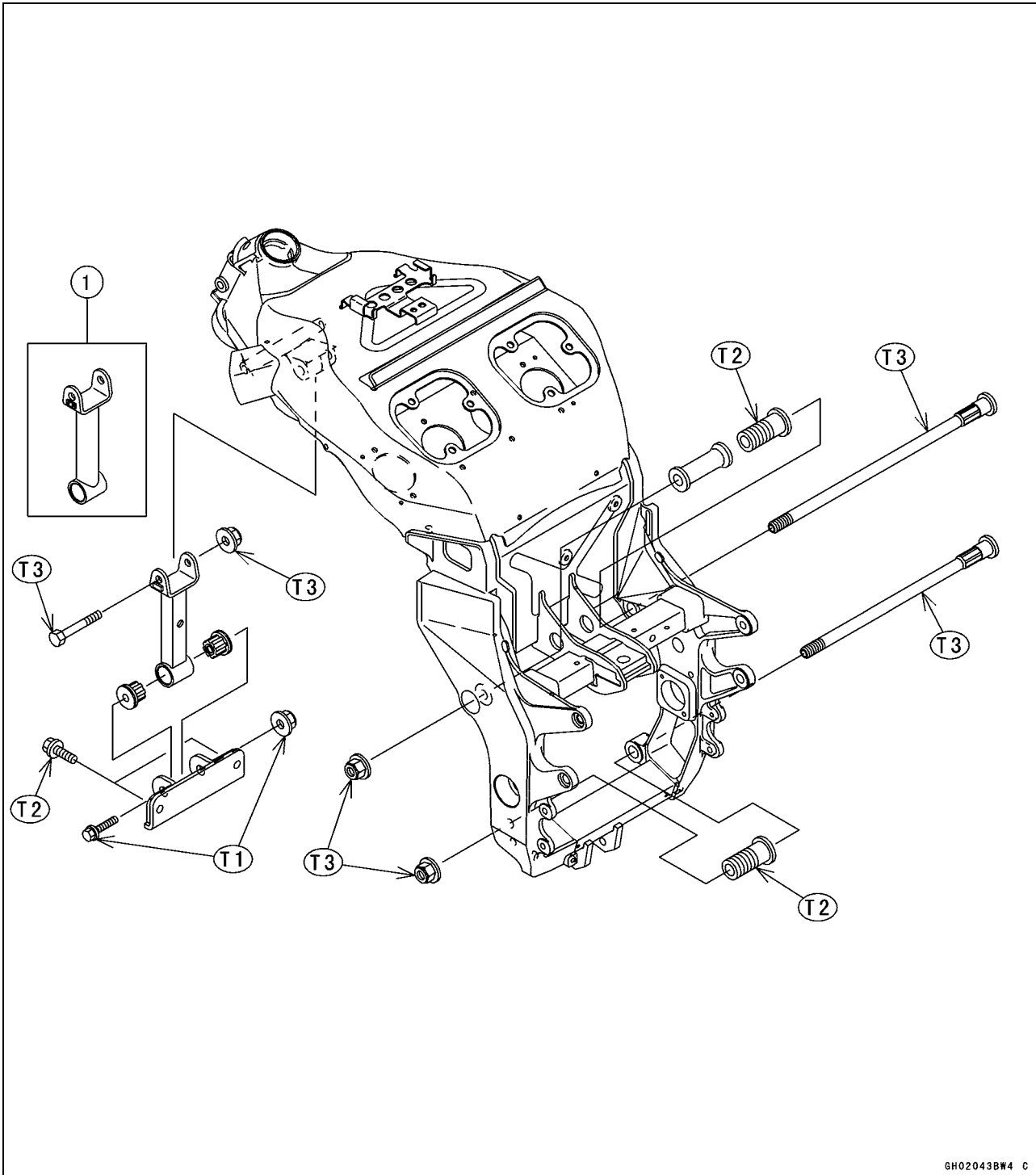

GH02043BW4 C

1. Engine Mounting Bracket (ZX1200-B1)

T1: 44 N·m (4.5 kgf·m, 32 ft·lb)

T2: 25 N·m (2.5 kgf·m, 18 ft·lb)

T3: 59 N·m (6.0 kgf·m, 44 ft·lb)

Engine Removal/Installation

Engine Removal

- Support the rear part of the swingarm with a stand [A].



- Squeeze the brake lever slowly and hold it with band [A].

! WARNING

Be sure to hold the front brake when removing the engine, or the motorcycle may fall over. It could cause an accident and injury.



CAUTION

Be sure to hold the front brake when removing the engine, or the motorcycle may fall over. The engine or the motorcycle could be damage.

- Drain:
 - Engine Oil (see Engine Oil Change in the Periodic Maintenance chapter)
 - Coolant (see Coolant Change in the Periodic Maintenance chapter)
- Remove:
 - Lower Fairings with Lower Inner Fairing (see Frame chapter)
- Set up the fuel tank [A] with the supporting rod [B] (see Fuel System (DFI) chapter).

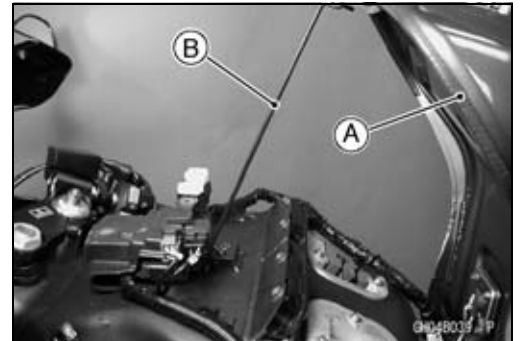

CAUTION

Do not insert the supporting rod into the bolt hole, or the thread of the bolt hole could be damaged.

- Turn the ignition switch OFF.
- Remove:
 - Battery Compartment Cover (see Electrical System chapter)
 - Battery Ground Cable [A]
 - Starter Motor Cable [B]
 - Vehicle-down Sensor/Starter Relay Connector [C]
 - Gear Position Switch and Engine Sub Harness Connectors [D]
 - Alternator Lead Connector [E]

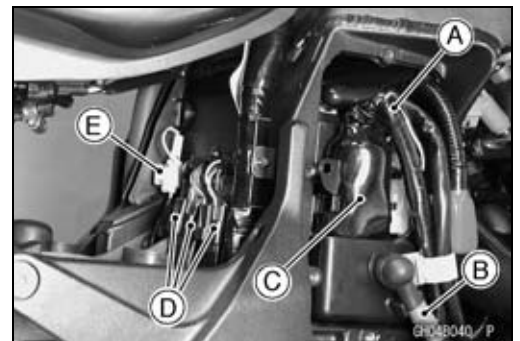

CAUTION

Do not disconnect the battery cables or any other electrical connections when the ignition switch is ON, as this could damage the ECU. Never reverse the connections of the battery, as this could damage the ECU.

8-4 ENGINE REMOVAL/INSTALLATION

Engine Removal/Installation

- Remove:
 - Radiator (see Cooling System chapter)
 - Muffler (see Engine Top End chapter)
 - Choke Cable Lower End
 - Throttle Cable Lower Ends
 - Air Cleaner Caps (see Fuel System (DFI) chapter)
 - Inlet Ducts [A] (see Fuel System (DFI) chapter)

- Remove:
 - Coolant Reserve Tank (see Cooling System chapter)
 - Shift Lever End (see Crankshaft /Transmission chapter)
 - Engine Sprocket Cover (see Final Drive chapter)
 - Engine Sprocket with Drive Chain (see Final Drive chapter)
 - Fuel Supply Hose End at Fuel Tank (see Fuel System (DFI) chapter)
 - Inlet Air Pressure Sensor [A]
 - Breather Hose End [B]
 - Sidestand Switch Lead Connector [C]
 - Vacuum Hose [I]
 - Alternator Lead Connector [G] (from Regulator Rectifier)
- Run the lead connector between the frame and rear fender front end pushing the rear fender front downward.
 - Housing Harness Connectors [H]
- For California Model:
 - Canister Purge Hose
- Support the engine with a suitable stand [E].
- Put a plank [D] onto the suitable stand for engine balance.
- Remove:
 - Engine Mounting Bracket Upper Bolt [F]
 - Engine Mounting Nuts [J]

- Turn the engine mounting bolts [A] clockwise to make the gap between the engine (adjusting collar) and frame.
- Remove:
 - Engine Mounting Bolts
 - Collar
 - Engine Mounting Brackets [B]
- Using the stand [C], take out the engine.

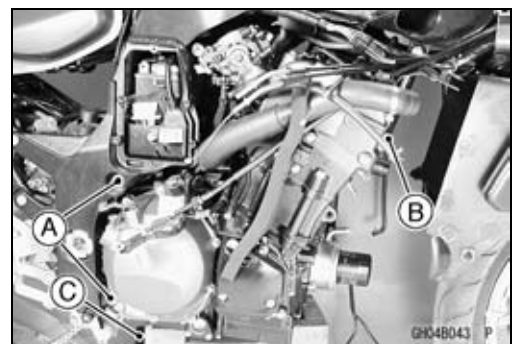
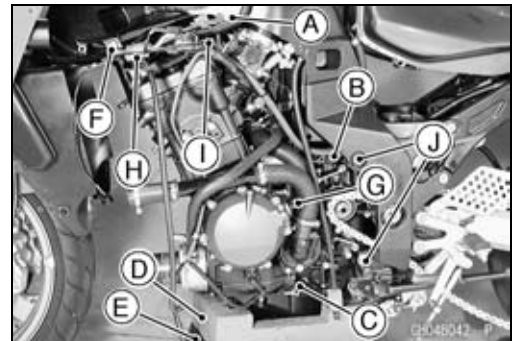
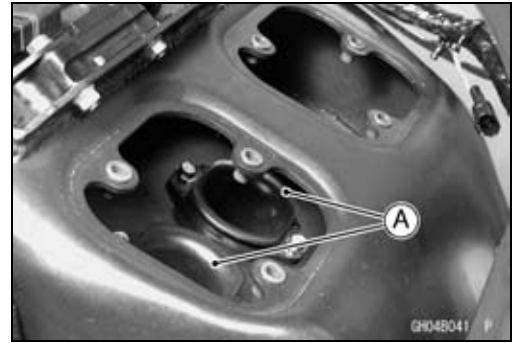

Engine Removal/Installation

Engine Installation

CAUTION

Do not connect the throttle sensor connector to the inlet air pressure sensor, because the pressure sensor is broken by the opposite electrical connection.

- Before the engine installing, install the following parts.
Engine Sub Harness [A]
Gear Position Switch Harness [B]
Alternator Leads [D]
- Confirm:
Cooling Hoses [C] Position
- Confirm the leads and hoses position as shown.
Clamps [A], [C]
Alternator Lead (Yellow) [B]
Alternator Lead (White) [D]
Gear Position Switch Lead [E]
Engine Sub Harness [F]
Fuel Supply Hose [G]
Tube [H]
Tube [I] (for California Model)
- Tighten the adjusting collars [A] fully by hand.
Crankcase [B]

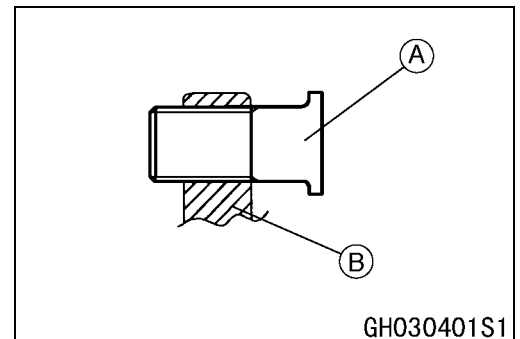
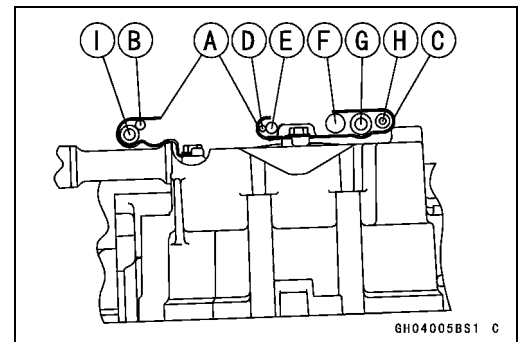
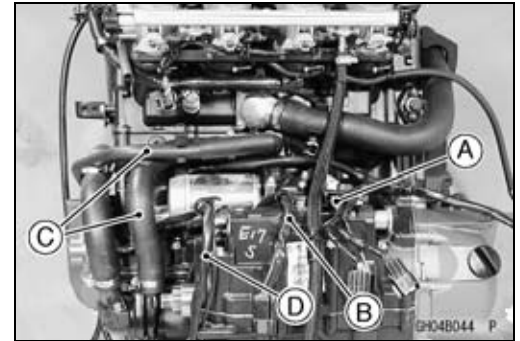

- Support the engine with a suitable stand.
- Hang the drive chain over the output shaft just before moving the engine into its final position in the frame.
- Insert the lower mounting bolt [A].
- Set the collar [B] and insert the upper mounting bolt [C].

NOTE

○ Before inserting the engine mounting bolts, verify that the fuel hose and tubes (one tube for California model only), alternator lead connectors, gear position switch and engine sub harness connectors are clear an opening between the frame and engine.

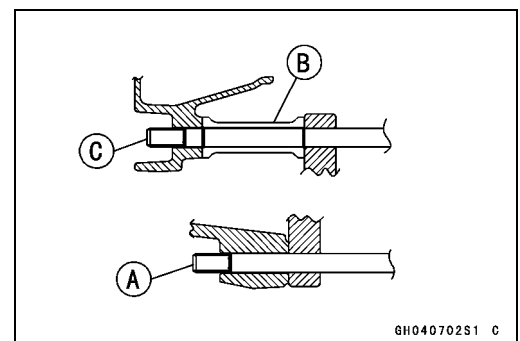

8-6 ENGINE REMOVAL/INSTALLATION

Engine Removal/Installation

- Install the engine mounting bracket [A] to the engine.
Torque - Engine Mounting Bolts (M8) [B]: 25 N·m (2.5 kgf·m, 18 ft·lb)
- Install the engine mounting bracket [C] temporarily.
Engine Mounting Bracket Bolt (M12) [D]
Engine Mounting Bracket Bolt (M10) [E]

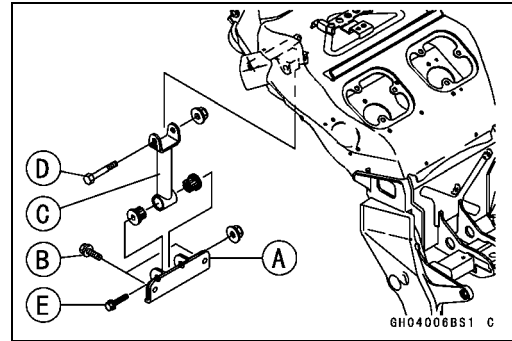

- Insert the mounting bolts [A] until they fit in the adjusting collars [B].
- Turn the mounting bolts counterclockwise with specified torque until the clearance [C] between the crankcase [D] and frame [E] come to zero mm [F].
Torque - Adjusting Collars: 25 N·m (2.5 kgf·m, 18 ft·lb)

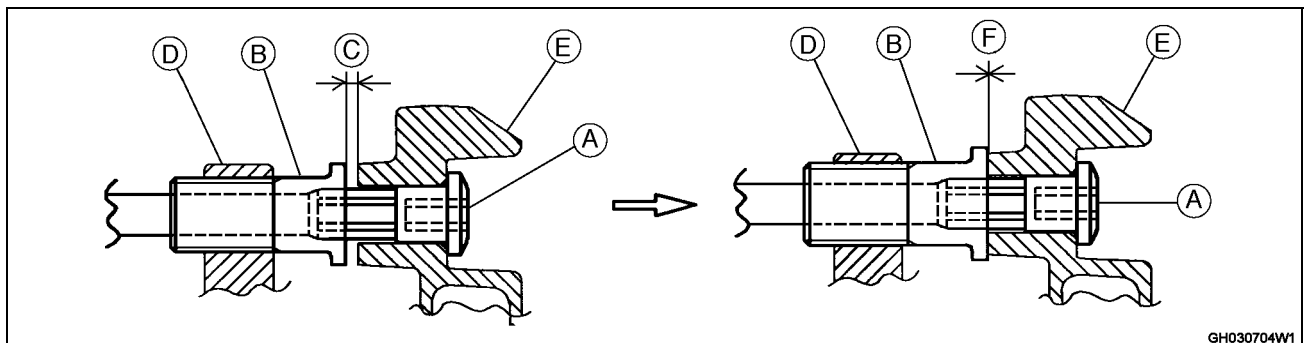

- Hold the upper and lower engine mounting bolts with an Allen wrench, and tighten the nuts [A] with specified torque.
Torque - Engine Mounting Nuts (M12): 59 N·m (6.0 kgf·m, 44 ft·lb)



- Tighten the engine mounting bracket bolts [B] with the sequence lower and upper.
Engine Mounting Bolts (M8) [C]
Torque - Lower Engine Mounting Bracket Bolt (M10): 44 N·m (4.5 kgf·m, 32 ft·lb)
Upper Engine Mounting Bracket Bolt (M12): 59 N·m (6.0 kgf·m, 44 ft·lb)

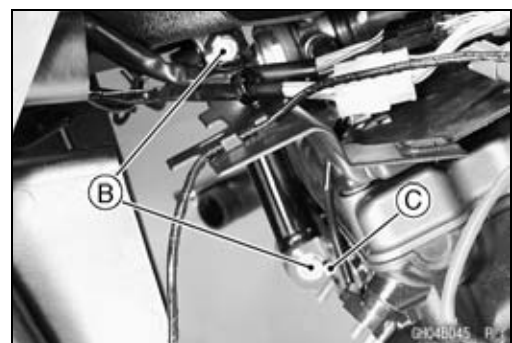

- Install the removed parts (see appropriate chapters).
- Adjust:
 - Throttle Cables (see Fuel System (DFI) chapter)
 - Choke Cable (see Fuel System (DFI) chapter)
 - Clutch Cable (see Clutch chapter)
 - Drive Chain (see Final Drive chapter)

Crankshaft/Transmission

Table of Contents

Exploded View.....	9-2	Starter Motor Clutch Installation...	9-21
Specifications	9-4	Starter Motor Clutch Disassembly	9-21
Crankcase Splitting.....	9-7	Starter Motor Clutch Assembly	9-22
Crankcase Splitting	9-7	Starter Clutch Inspection.....	9-22
Crankcase Assembly	9-7	Torque Limiter Removal	9-23
Crankshaft and Connecting Rods.....	9-11	Torque Limiter Installation	9-23
Crankshaft Removal	9-11	Transmission	9-24
Crankshaft Installation	9-11	Shift Pedal Removal	9-24
Connecting Rod Removal.....	9-11	Shift Pedal Installation	9-24
Connecting Rod Installation	9-11	External Shift Mechanism	
Connecting Rod Bend.....	9-13	Removal.....	9-25
Connecting Rod Twist.....	9-14	External Shift Mechanism	
Connecting Rod Big End Side		Installation	9-26
Clearance.....	9-14	External Shift Mechanism	
Connecting Rod Big End Bearing		Inspection.....	9-26
Insert/Crankpin Wear	9-14	Transmission Shaft Removal	9-26
Crankshaft Main Bearing		Transmission Shaft Installation	9-27
Insert/Journal Wear.....	9-16	Transmission Disassembly	9-27
Crankshaft Side Clearance	9-17	Transmission Assembly	9-28
Crankshaft Runout.....	9-18	Shift Drum and Fork Removal.....	9-30
Balancer	9-19	Shift Drum and Fork Installation...	9-31
Balancer Removal.....	9-19	Shift Drum Disassembly.....	9-31
Balancer Installation.....	9-19	Shift Drum Assembly	9-32
Balancer Damper Inspection.....	9-20	Shift Fork Bending	9-32
Starter Motor Clutch and Torque		Shift Fork/Gear Groove Wear	9-32
Limiter	9-21	Shift Fork Guide Pin/Drum	
Starter Motor		Groove Wear.....	9-32
Removal/Installation.....	9-21	Gear Dog and Gear Dog Hole	
Starter Motor Clutch Removal.....	9-21	Damage.....	9-33

9-2 CRANKSHAFT/TRANSMISSION

Exploded View

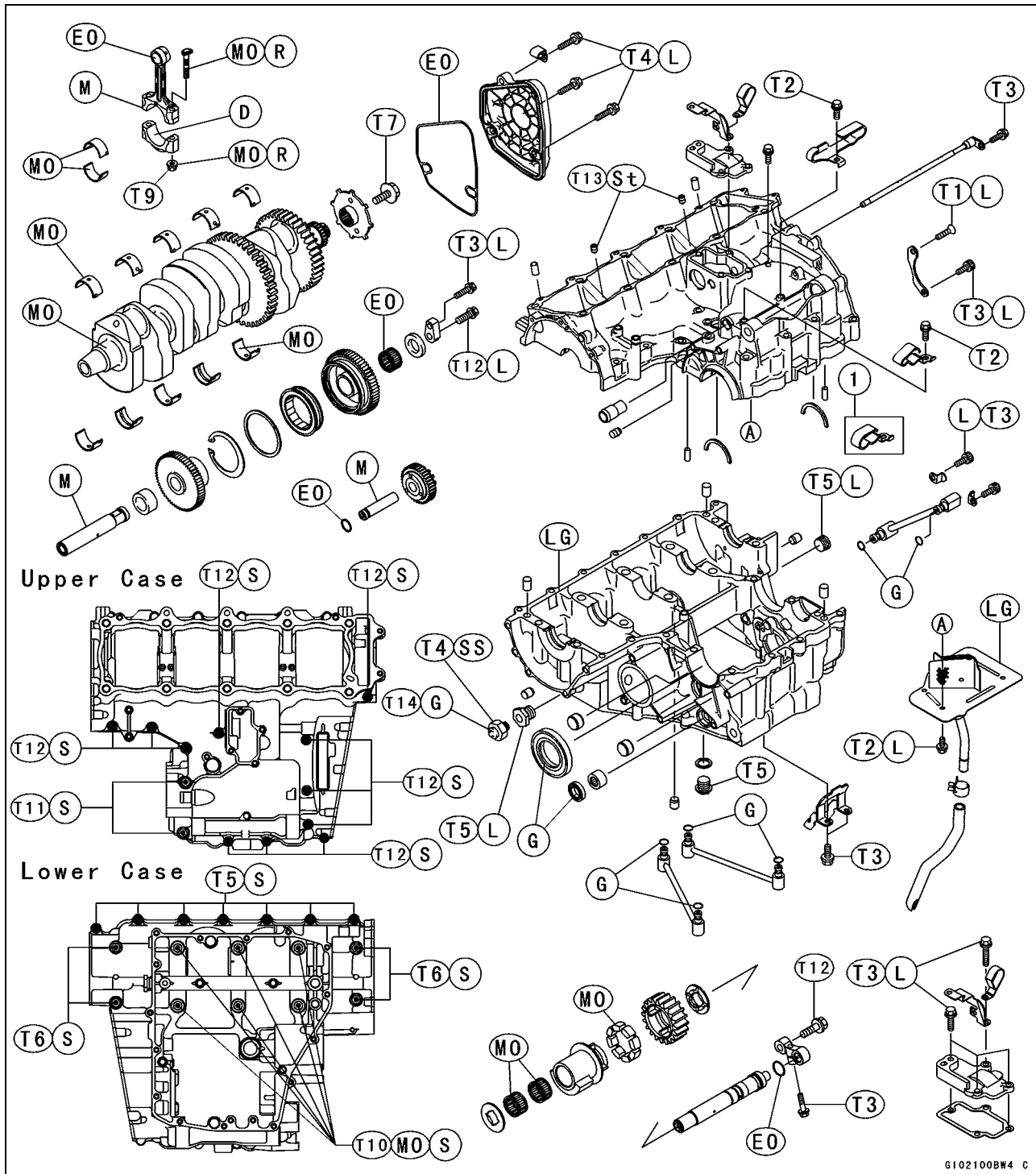

G102100B4 C

- 1. Clamp (ZX1200-B1/B2)
- T1: 5.4 N·m (0.55 kgf·m, 48 in·lb)
- T2: 10 N·m (1.0 kgf·m, 89 in·lb)
- T3: 12 N·m (1.2 kgf·m, 106 in·lb)
- T4: 15 N·m (1.5 kgf·m, 11 ft·lb)
- T5: 20 N·m (2.0 kgf·m, 15 ft·lb)
- T6: 23 N·m (2.3 kgf·m, 17 ft·lb)
- T7: 39 N·m (4.0 kgf·m, 29 ft·lb)

- T8: 30 N·m (3.0 kgf·m, 22 ft·lb)
- T9: See the text.
- T10: 50 N·m (5.0 kgf·m, 37 ft·lb)
- T11: 28 N·m (2.8 kgf·m, 21 ft·lb)
- T12: 25 N·m (2.5 kgf·m, 18 ft·lb)
- T13: 2.5 N·m (0.25 kgf·m, 22 in·lb)
- T14: 1.5 N·m (0.15 kgf·m, 13 in·lb)

Exploded View

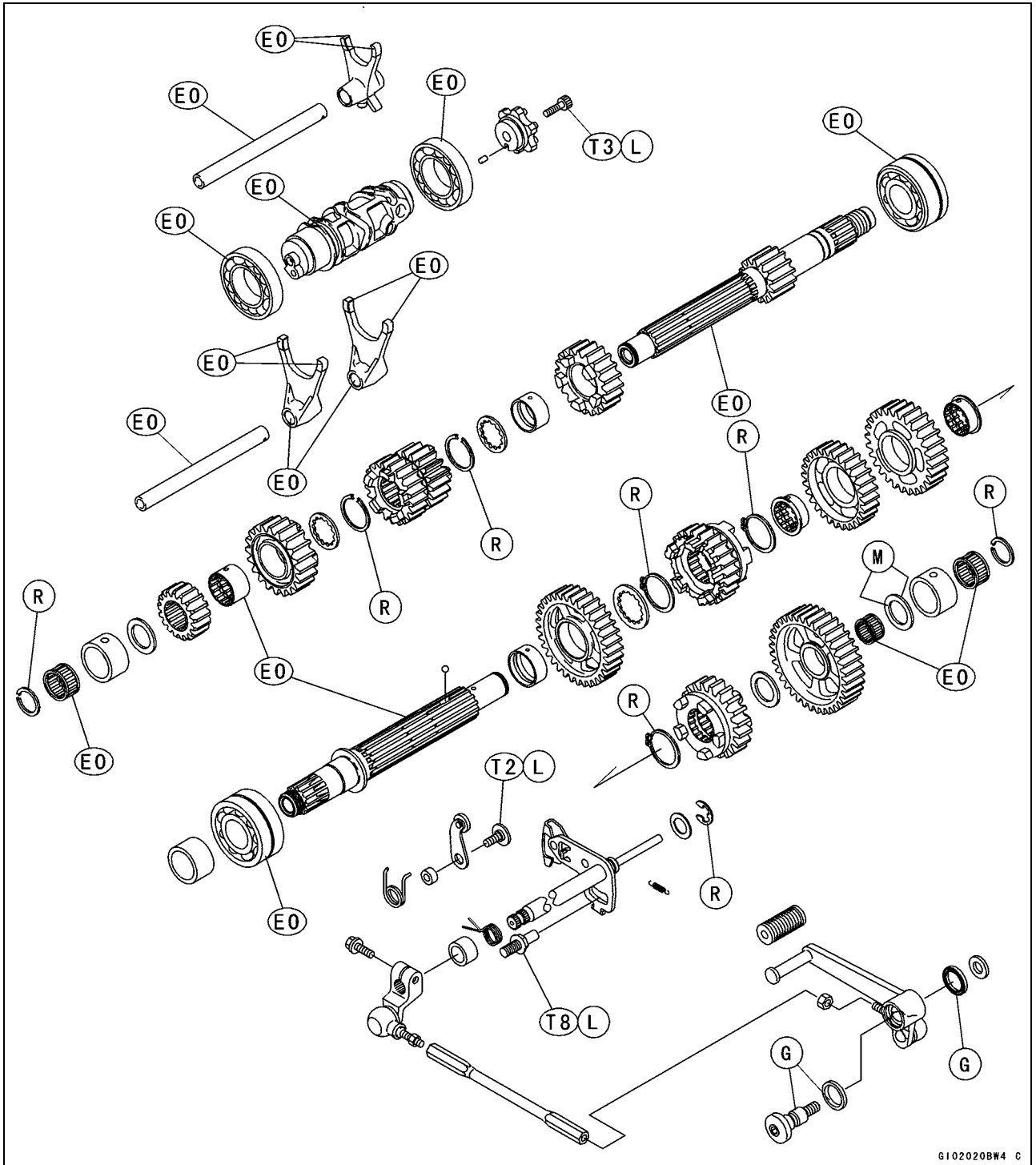

6102020BW4 C

- D: Do not apply any grease or oil.
- EO: Apply engine oil.
- G: Apply grease.
- L: Apply a non-permanent locking agent.
- LG: Apply liquid gasket (Three Bond 1207B).
- M: Apply molybdenum disulfide grease.
- MO: Apply molybdenum disulfide oil solution.
- R: Replacement Parts
- S: Follow the specific tightening sequence.
- SS: Apply silicone sealant.
- St: Stake the fasteners to prevent loosening.

9-4 CRANKSHAFT/TRANSMISSION

Specifications

Item	Standard	Service Limit																					
Crankshaft, Connecting Rods																							
Connecting Rod Bend	---	0.2/100 mm (0.008/3.94 in.)																					
Connecting Rod Twist	---	0.2/100 mm (0.008/3.94 in.)																					
Connecting Rod Big End Side Clearance	0.13 ~ 0.38 mm (0.0051 ~ 0.0150 in.)	0.58 mm (0.023 in.)																					
Connecting Rod Big End Bearing Insert/Crankpin Clearance	0.048 ~ 0.084 mm (0.0019 ~ 0.0033 in.)	0.10 mm (0.0039 in.)																					
Crankpin Diameter:	36.984 ~ 37.000 mm (1.4561 ~ 1.4567 in.)	36.97 mm (1.456 in.)																					
Marking	None	---																					
	○	---																					
Connecting Rod Big End Bore Diameter:	40.000 ~ 40.016 mm (1.5748 ~ 1.5754 in.)	---																					
Marking	None	---																					
	○	---																					
Connecting Rod Big End Bearing Insert Thickness:																							
	Brown	1.475 ~ 1.480 mm (0.05807 ~ 0.05827 in.)																					
	Black	1.480 ~ 1.485 mm (0.05827 ~ 0.05846 in.)																					
	Blue	1.485 ~ 1.490 mm (0.05846 ~ 0.05866 in.)																					
Connecting Rod Big End Bearing Insert Selection																							
<table border="1"> <thead> <tr> <th rowspan="2">Con-rod Big End Bore Diameter Marking</th> <th rowspan="2">Crankpin Diameter Marking</th> <th colspan="2">Bearing Insert</th> </tr> <tr> <th>Size Color</th> <th>Part Number</th> </tr> </thead> <tbody> <tr> <td>None</td> <td>○</td> <td>Brown</td> <td>92139-1093</td> </tr> <tr> <td>None</td> <td>None</td> <td rowspan="2">Black</td> <td rowspan="2">92139-1092</td> </tr> <tr> <td>○</td> <td>○</td> </tr> <tr> <td>○</td> <td>None</td> <td>Blue</td> <td>92139-1091</td> </tr> </tbody> </table>				Con-rod Big End Bore Diameter Marking	Crankpin Diameter Marking	Bearing Insert		Size Color	Part Number	None	○	Brown	92139-1093	None	None	Black	92139-1092	○	○	○	None	Blue	92139-1091
Con-rod Big End Bore Diameter Marking	Crankpin Diameter Marking	Bearing Insert																					
		Size Color	Part Number																				
None	○	Brown	92139-1093																				
None	None	Black	92139-1092																				
○	○																						
○	None	Blue	92139-1091																				
Connecting Rod Bolt Stretch (Usable Range)																							
New Connecting Rod	0.25 ~ 0.34 mm (0.0094 ~ 0.014 in.)	---																					
Used Connecting Rod	0.20 ~ 0.32 mm (0.0079 ~ 0.013 in.)	---																					

CRANKSHAFT/TRANSMISSION 9-5

Specifications

Item	Standard	Service Limit
Crankshaft Side Clearance	0.05 ~ 0.20 mm (0.0020 ~ 0.0079 in.)	0.40 mm (0.016 in.)
Crankshaft Runout	TIR 0.03 mm (0.0012 in.) or less	TIR 0.07 mm (0.0028 in.)
Crankshaft Main Bearing Insert/Journal Clearance	0.031 ~ 0.063 mm (0.0012 ~ 0.0025 in.)	0.07 mm (0.003 in.)
Crankshaft Main Journal Diameter:	36.984 ~ 37.000 mm (1.4561 ~ 1.4567 in.)	36.96 mm (1.455 in.)
Marking	None	---
	1	---
Crankcase Main Bearing Bore Diameter:	40.000 ~ 40.016 mm (1.5748 ~ 1.5754 in.)	---
Marking	○	---
	None	---
Crankshaft Main Bearing Insert Thickness:		
Brown	1.490 ~ 1.494 mm (0.05866 ~ 0.05882 in.)	---
Black	1.494 ~ 1.498 mm (0.05882 ~ 0.05898 in.)	---
Blue	1.498 ~ 1.502 mm (0.05898 ~ 0.05913 in.)	---

Crankshaft Main Bearing Insert Selection

Crankcase Main Bearing Bore Diameter Marking	Crankshaft Main Journal Diameter Marking	Bearing Insert*		
		Size Color	Part Number	Journal Nos.
○	1	Brown	92028-1997	1, 5
			92139-1055	3
			92139-1052	2, 4
○	None	Black	92028-1996	1, 5
			92139-1054	3
None	1	Black	92139-1051	2, 4
			92028-1995	1, 5
None	None	Blue	92139-1053	3
			92028-1998	2, 4

*The bearing inserts for Nos. 2, 3 and 4 journals have an oil groove, respectively.

Transmission		
Shift Fork Ear Thickness	5.9 ~ 6.0 mm (0.232 ~ 0.236 in.)	5.8 mm (0.228 in.)

9-6 CRANKSHAFT/TRANSMISSION

Specifications

Item	Standard	Service Limit
Gear Shift Fork Groove Width	6.05 ~ 6.15 mm (0.238 ~ 0.242 in.)	6.25 mm (0.246 in.)
Shift Fork Guide Pin Diameter	6.9 ~ 7.0 mm (0.272 ~ 0.276 in.)	6.8 mm (0.268 in.)
Shift Drum Groove Width	7.05 ~ 7.20 mm (0.278 ~ 0.283 in.)	7.3 mm (0.287 in.)

Special Tools - Bearing Puller: 57001-135

Steering Stem Bearing Driver: 57001-137

Outside Circlip Pliers: 57001-144

Bearing Puller Adapter: 57001-317

Sealant - Kawasaki Bond (Silicone Sealant): 56019-120

Kawasaki Bond (Silicone Sealant): 92104-1062

Three Bond 1207B

Crankcase Splitting

Crankcase Splitting

- Remove the engine (see Engine Removal/Installation chapter).
- Set the engine on a clean surface and hold the engine steady while parts are being removed.
- Remove:
 - Crankshaft Sensor (see Electrical System chapter)
 - Clutch (see Clutch chapter)
 - External Shift Mechanism (see External Shift Mechanism Removal)
 - Starter Motor (see Electrical System chapter)
 - Oil Pump (see Engine Lubrication System chapter)
 - Alternator Rotor (see Electrical System chapter)
 - Oil Filter (see Oil Filter Replace in the Periodic Maintenance chapter)
 - Oil Cooler (see Engine Lubrication System chapter)
- ★ If the crankshaft is to be removed, remove the pistons (see Engine Top End chapter).

- Remove the upper crankcase bolts.
 - First loosen the M7 bolts.
 - M7 Bolts [A]
 - M8 Bolts [B]

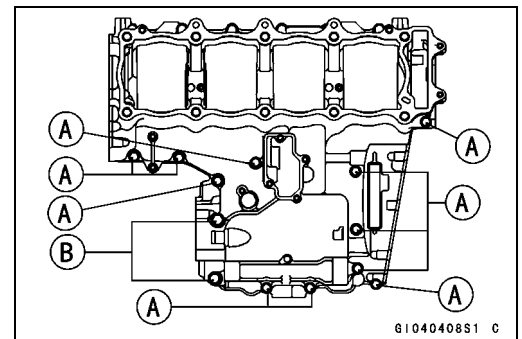

- Remove the oil pan, relief valve, oil screen and oil pipes (see Engine Lubrication System chapter).
- Remove the lower crankcase bolts.
 - First loosen the M7 bolts.
 - M7 Bolts [A]
 - M8 Bolts [B]
 - M10 Bolts [C]
- Tap lightly around the crankcase mating surface with a plastic mallet, and split the crankcase. Take care not to damage the crankcase.

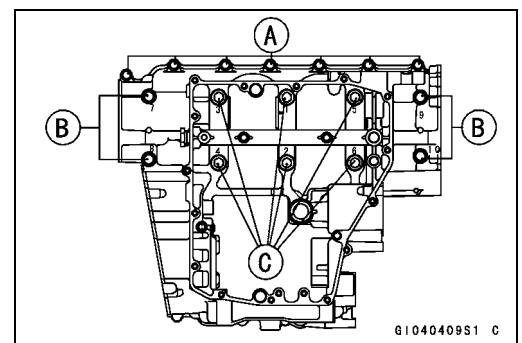

Crankcase Assembly

CAUTION

The upper and lower crankcase halves are machined at the factory in the assembled state, so the crankcase halves must be replaced as a set.

- With high-flash point solvent, clean off the mating surfaces of the crankcases halves and wipe dry.
- Using compressed air, blow out the oil passages in the crankcase halves.

9-8 CRANKSHAFT/TRANSMISSION

Crankcase Splitting

- Apply liquid gasket to the breather plate mating surface [A] 1 to 1.5 mm (0.04 to 0.06 in.) thick, and then install the breather plate.

Sealant - Three Bond 1207B

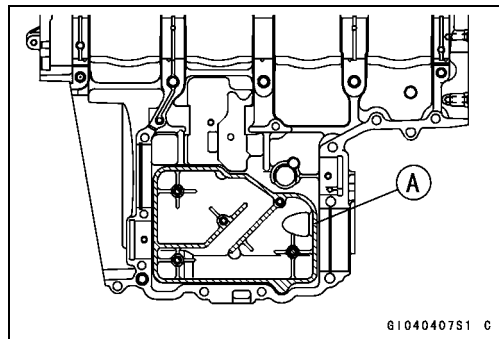

- Apply a non-permanent locking agent to the threads and tighten the breather plate mounting bolts [A].

Torque - Breather Plate Bolts: 10 N·m (1.0 kgf·m, 89 in·lb)

- Insert the oil pipe [B] completely and tighten the bolt.

Torque - Oil Pipe Holder Bolt: 12 N·m (1.2 kgf·m, 106 in·lb)

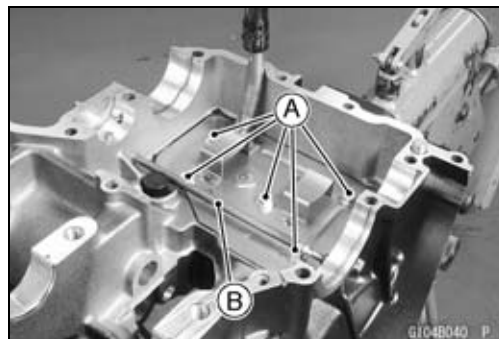

- Install the breathe hose [A].
 - Align the white paint marks [B].
 - Install the clamp so that its head [C] come to the inward.

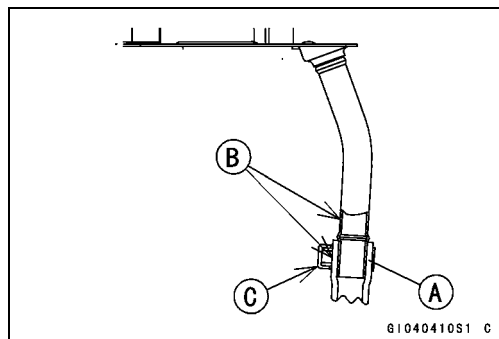

- Install:
 - Starter Motor Clutch (see Starter Motor Clutch Installation)
 - Crankshaft and Connecting Rods [A]
 - Camshaft Chain [B]
 - Transmission Shafts and Gears [C]
 - Dowel Pins [D]
 - Balancer (see Balancer Installation)
 - Shift Drum (see Shift Drum and Fork Installation)
 - Shift Forks and Shift Rods (see Shift Drum and Fork Installation)
- Before fitting the lower case on the upper case, check the following.
 - Be sure to hang the camshaft chain on the crankshaft.
 - Check to see that the shift drum and transmission gears are in the neutral position.

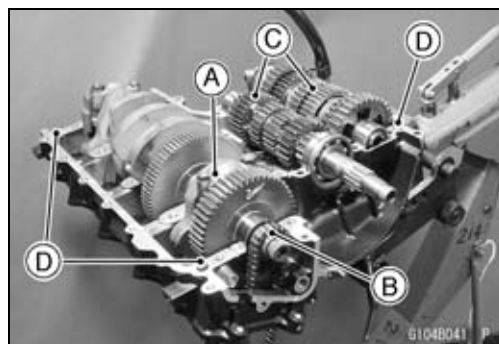

Crankcase Splitting

- Apply liquid gasket [A] to the mating surface of the lower crankcase half.
- Pile up the gasket [B] to slot portions.

NOTE

- Make the application finish within 5 minutes when the liquid gasket to the mating surface of the lower crankcase half is applied.
- Moreover fit the case and tighten the case bolts just after finishing the application of the liquid gasket.

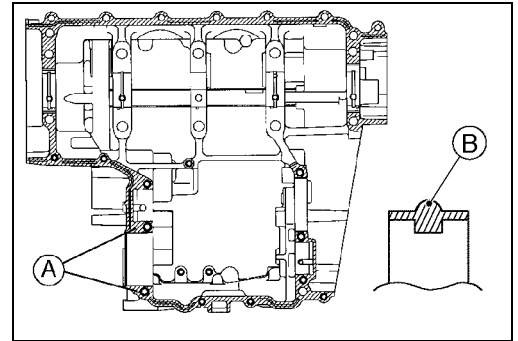

Sealant - Three Bond 1207B

CAUTION

Do not apply liquid gasket around the crankshaft main bearing inserts, and oil passage holes.

- Position the crankshaft at #1, 4 position TDC.
- Hold the balancer so that the punch mark [A] on the balancer weight aligns with the projection [B] of the lower crankcase.
- Fit the lower crankcase to the upper crankcase.



- Apply molybdenum disulfide oil solution to the seating surface of the M10 bolt heads.
- Tighten the lower crankcase bolts.
- Following the sequence numbers on the lower crankcase half, tighten the M10 bolts [1 ~ 6] [C].

Torque - Crankcase Bolts (M10): 50 N·m (5.0 kgf·m, 37 ft·lb)

- Following the sequence numbers, tighten the M8 bolts [7 ~ 10] [B].

Torque - Lower Crankcase Bolts (M8): 23 N·m (2.3 kgf·m, 17 ft·lb)

- Tighten the M7 bolts [A].

Torque - Lower Crankcase Bolts (M7): 20 N·m (2.0 kgf·m, 15 ft·lb)

- Put the M8 bolts [A], M7 bolts [B], and the M7 bolt with the washer [C] into the upper crankcase half as shown in the figure, tighten the M8 bolts first, then the other bolts.

Torque - Upper Crankcase Bolts (M8): 28 N·m (2.8 kgf·m, 21 ft·lb)

Upper Crankcase Bolts (M7): 25 N·m (2.5 kgf·m, 18 ft·lb)

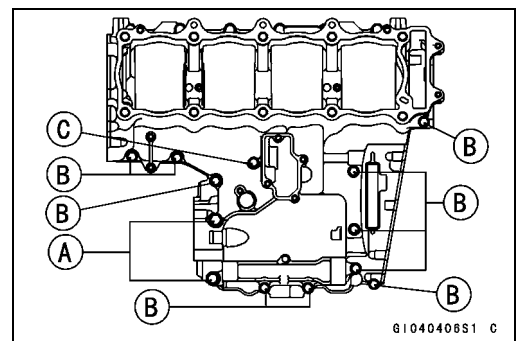
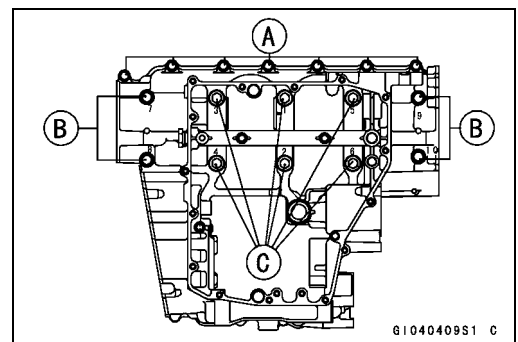

9-10 CRANKSHAFT/TRANSMISSION

Crankcase Splitting

- After tightening all crankcase bolts, check the following items.
- Crankshaft and transmission shafts turn freely.
- While spinning the output shaft, gears shift smoothly from the 1st to 6th gear, and 6th to 1st.
- When the output shaft stays still, the gear can not be shifted to 2nd gear or other higher gear positions.

Crankshaft and Connecting Rods

Crankshaft Removal

- Split the crankcase (see Crankcase Splitting).
- Remove the crankshaft.

Crankshaft Installation

CAUTION

If the crankshaft, bearing inserts, or crankcase halves are replaced with new ones, select the bearing inserts and check clearance with a plastigage before assembling engine to be sure the correct bearing inserts are installed.

- Apply molybdenum disulfide oil solution to the crankshaft main bearing inserts.
- Install the crankshaft with the camshaft chain [A] hanging on it.
- Assemble the crankcase (see Crankcase Assembly).

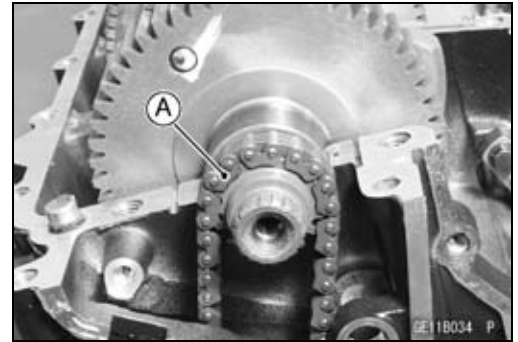

Connecting Rod Removal

- Split the crankcase (see Crankcase Splitting).
- Remove the connecting rod nuts [A].
- Remove the crankshaft.

NOTE

○ Mark and record the locations of the connecting rods and their big end caps so that they can be reassembled in their original positions.

- Remove the connecting rods from the crankshaft.

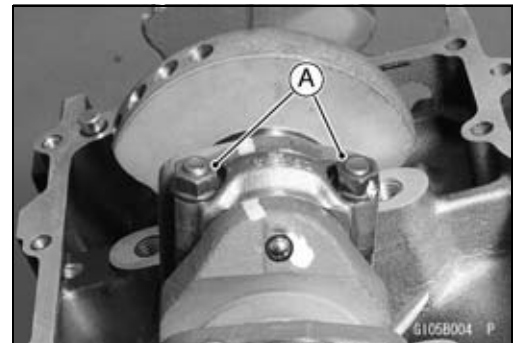

Connecting Rod Installation

⚠ WARNING

Clean the crankshaft, bolts, nuts, and connecting rods in a well-ventilated area, and take care that there is no spark or flame anywhere near the working area. This includes any appliance with a pilot light. Because of the danger of highly flammable liquids, do not use gasoline or low-flash point solvents to clean them.

- After removing the connecting rods from the crankshaft, clean them with high-flash point solvent.
- Blow the crankshaft oil passages with compressed air to remove any foreign particles or residue that may have accumulated in the passages.

9-12 CRANKSHAFT/TRANSMISSION

Crankshaft and Connecting Rods

CAUTION

To minimize vibration, the connecting rods should have the same weight mark.

- Big End Cap [A]
- Connecting Rod [B]
- Weight Mark, Alphabet [C]
- Diameter Mark [D]

- ★ If the connecting rods, big end bearing inserts, or crankshaft are replaced with new ones, select the bearing insert and check clearance with a plastigage before assembling engine to be sure the correct bearing inserts are installed.

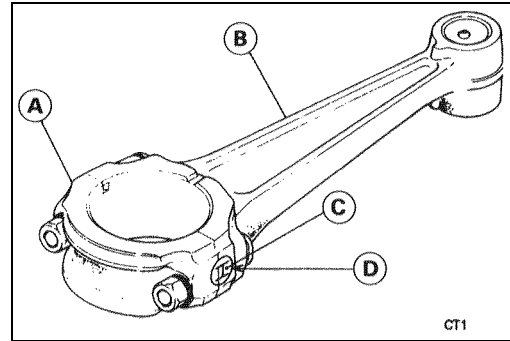

CAUTION

The connecting rod bolts are designed to stretch when tightened. Never reuse them. See the table below for correct bolt and nut usage.

- Apply grease and oil to the following portions.
 - Apply molybdenum disulfide grease [A].
 - Do not apply grease and oil [B].
 - Apply molybdenum disulfide oil solution [C].

CAUTION

Do not apply grease to the inner surface of the lower big end cap or to the outer surface of the lower bearing insert.

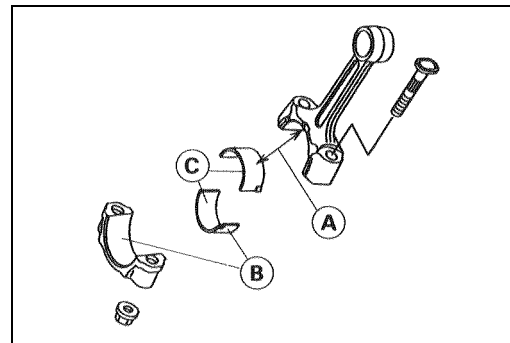

- Install the bearing insert as shown to prevent its outer surface from scratch damage with connecting rod edge.
 - Connecting Rod Side Bearing Insert [A]
 - Dowel Pin [B]
 - Claw Side [C]
 - Cap Side Bearing Insert [D]
 - Connecting Rod Cap [E]

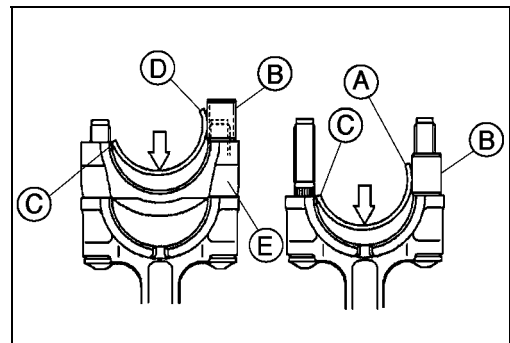

- Replace the connecting rod big end bolts and nuts with new ones.
- Be sure to clean the bolts, nuts, and connecting rods thoroughly with high-flash point solvent, because the new connecting rods, bolts, and nuts are treated with anti-rust solution.

CAUTION

Immediately dry the bolts and nuts with compressed air after cleaning. Clean and dry the bolts and nuts completely.

Crankshaft and Connecting Rods

- Apply small amount of molybdenum disulfide oil solution to the threads [A] and seating surfaces [B] of the connecting rod nuts.

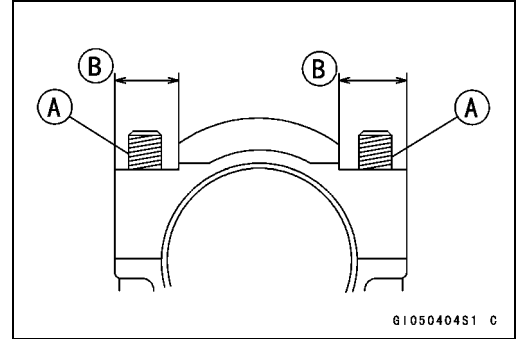

- First, tighten the nuts to the specified torque. See the table below.
- Next, tighten the nuts by 120° more.
- Mark [A] the connecting rod big end caps and nuts so that nuts can be turned 120° [B] properly.
- Tighten the hexagon nut by 2 corners.

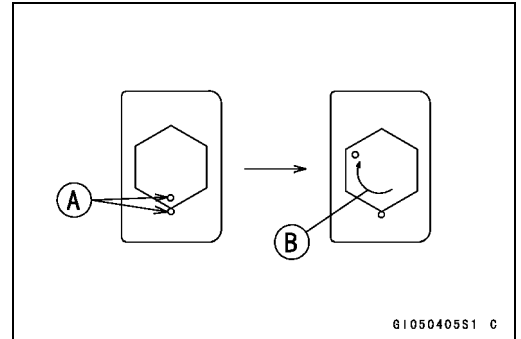

Connecting Rod Assy	Bolt, Nut	Torque + Angle N·m (kgf·m, ft·lb)
New	Use the bolts attached to new con-rod.	21.6 (2.2, 16) + 120°
	Another new bolts and nuts	21.6 (2.2, 16) + 120°
Used	Replace the bolts and nuts with new ones	21.6 (2.2, 16) + 120°

CAUTION

Since the friction force of the seating surface and thread portion of new nuts is different from that of used ones, the nut tightening torque should be changed as specified in the above table. Be careful not to overtighten the nuts.

Connecting Rod Bend

- Remove the connecting rod big end bearing inserts, and reinstall the connecting rod big end caps.
- Select an arbor [A] of the same diameter as the connecting rod big end, and insert the arbor through the connecting rod big end.
- Select an arbor of the same diameter as the piston pin at least 100 mm (3.94 in.) long, and insert the arbor [B] through the connecting rod small end.
- On a surface plate, set the big-end arbor on V blocks [C].
- Measure the difference in the heights of the arbor above the surface plate over a 100 mm (3.94 in.) distance-on the arbor to determine the amount of connecting rod bend with the connecting rod held vertically, and using a height gauge.
- ★ If connecting rod bend exceeds the service limit, the connecting rod must be replaced.

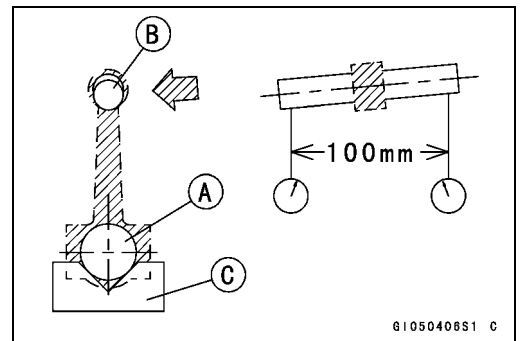

Connecting Rod Bend

Service Limit: 0.2/100 mm (0.008/3.94 in.)

9-14 CRANKSHAFT/TRANSMISSION

Crankshaft and Connecting Rods

Connecting Rod Twist

- On surface plate, set the big-end arbor on V block [C].
 - Measure the difference in the heights of the arbor above the surface plate over a 100 mm (3.94 in.) distance—on the arbor to determine the amount of connecting rod twist with the connecting rod held horizontally, and using a height gauge.
- ★ If connecting rod twist exceeds the service limit, the connecting rod must be replaced.

Connecting Rod Twist

Service Limit: 0.2/100 mm (0.008/3.94 in.)

Connecting Rod Big End Side Clearance

- Measure connecting rod big end side clearance [A].
- Insert a thickness gauge [B] between the big end and either crank web to determine clearance.

Connecting Rod Big End Side Clearance

Standard: 0.13 ~ 0.38 mm (0.0051 ~ 0.0150 in.)

Service Limit: 0.58 mm (0.023 in.)

- ★ If the clearance exceeds the service limit, replace the connecting rod with new one and then check clearance again. If clearance is too large after connecting rod replacement, the crankshaft also must be replaced.

Connecting Rod Big End Bearing Insert/Crankpin Wear

- Measure the bearing insert/crankpin [B] clearance with a plastigage [A].

NOTE

- Tighten the connecting rod big end nuts to the specified torque (see *Connecting Rod Installation*).
- Do not move the connecting rod and crankshaft during clearance measurement.

Connecting Rod Big End Bearing Insert/Crankpin Clearance

Standard: 0.048 ~ 0.084 mm (0.0019 ~ 0.0033 in.)

Service Limit: 0.10 mm (0.0039 in.)

- ★ If clearance is within the standard, no bearing replacement is required.
- ★ If clearance is between 0.085 mm (0.0033 in.) and the service limit (0.10 mm, 0.0039 in.), replace the bearing inserts [A] with inserts painted blue [B]. Check insert/crankpin clearance with the plastigage. The clearance may exceed the standard slightly, but it must not be less than the minimum in order to avoid bearing seizure.
- ★ If the clearance exceeds the service limit, measure the diameter of the crankpins.

Crankpin Diameter

Standard: 36.984 ~ 37.000 mm (1.4561 ~ 1.4567 in.)

Service Limit: 36.97 mm (1.456 in.)

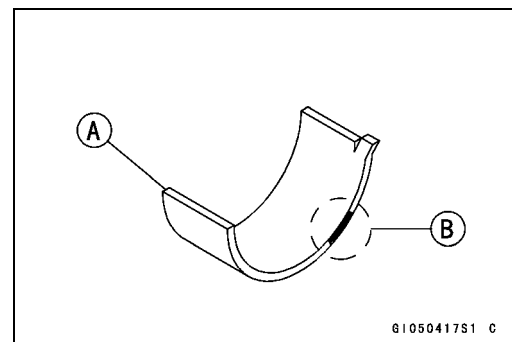
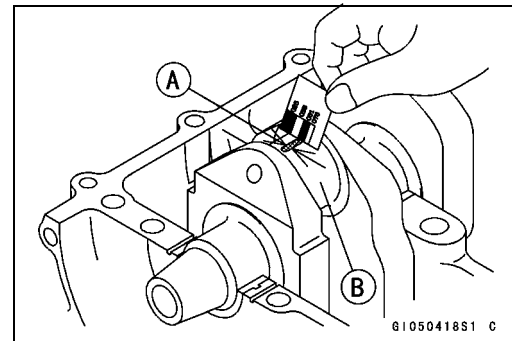
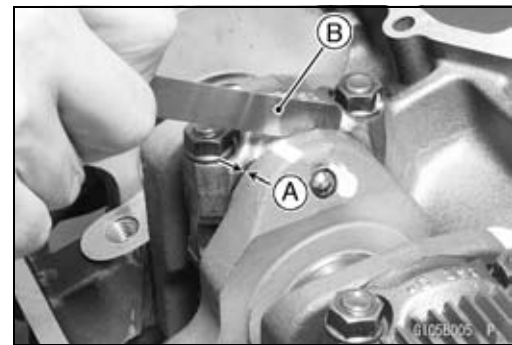
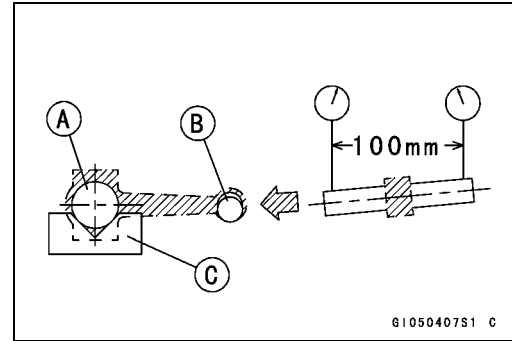

Crankshaft and Connecting Rods

- ★ If any crankpin has worn past the service limit, replace the crankshaft with a new one.
- ★ If the measured crankpin diameters are not less than the service limit, but do not coincide with the original diameter markings on the crankshaft, make new marks on it.

Crankpin Diameter Marks

- None 36.984 ~ 36.992 mm (1.4561 ~ 1.4564 in.)
- 36.993 ~ 37.000 mm (1.45641 ~ 1.4567 in.)

Δ: Crankpin Diameter Marks, "○" mark or no mark.

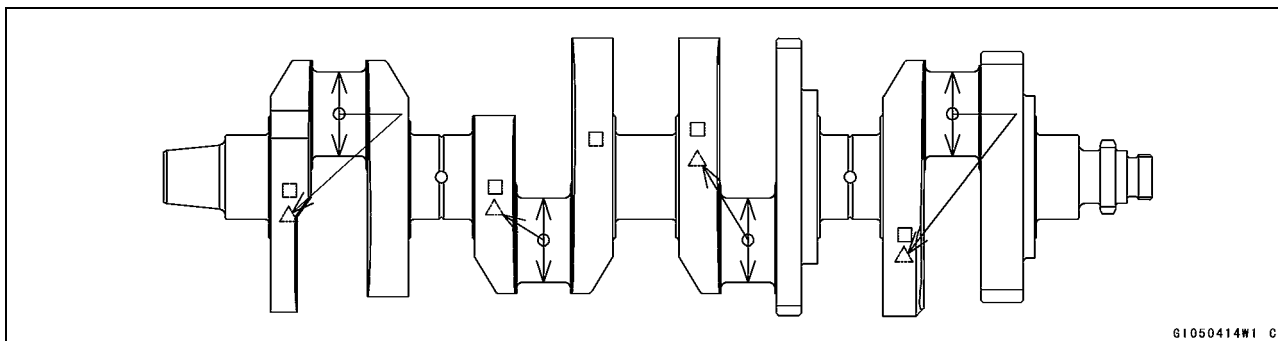

61050414W1 C

- Measure the connecting rod big end bore diameter, and mark each connecting rod big end in accordance with the bore diameter.

Big End Cap [A]

Connecting Rod [B]

Weight Mark [C]: A letter of the alphabet

Bore Diameter Mark (Around Weight Mark) [D]: "○" or no mark.

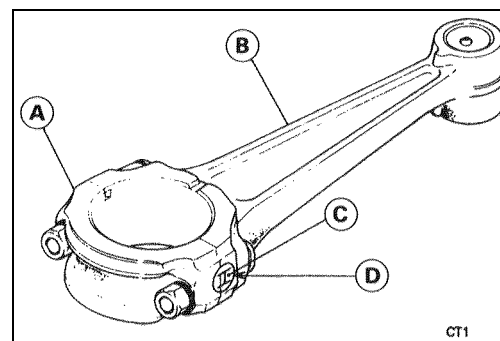

CT1

NOTE

- Tighten the connecting rod big end nuts to the specified torque (see *Connecting Rod Installation*).
- The mark already on the big end should almost coincide with the measurement.

Connecting Rod Big End Bore Diameter Marks

- None 40.000 ~ 40.008 mm (1.5748 ~ 1.5751 in.)
- 40.009 ~ 40.016 mm (1.5752 ~ 1.5754 in.)

- Select the proper bearing insert in accordance with the combination coding of the connecting rod and crankshaft.
- Install the new inserts in the connecting rod and check insert/crankpin clearance with the plastigage.

Con-rod Big End Bore Diameter Marking	Crankpin Diameter Marking	Bearing Insert	
		Size Color	Part Number
None	○	Brown	92139-1093
None	None	Black	92139-1092
○	○		
○	None	Blue	92139-1091

9-16 CRANKSHAFT/TRANSMISSION

Crankshaft and Connecting Rods

Crankshaft Main Bearing Insert/Journal Wear

- Measure the bearing insert/journal [B] clearance with a plastigage [A].

NOTE

- Tighten the crankcase bolts to the specified torque (see Crankcase Assembly).
- Do not turn the crankshaft during clearance measurement.
- Journal clearance less than 0.025 mm (0.0010 in.) can not be measured by plastigage, however, using genuine parts maintains the minimum standard clearance.

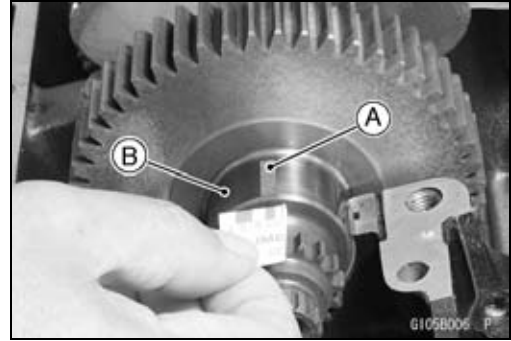

Crankshaft Main Bearing Insert/Journal Clearance

Standard: 0.031 ~ 0.063 mm (0.0012 ~ 0.0025 in.)

Service Limit: 0.07 mm (0.0031 in.)

- ★ If clearance is within the standard, no bearing replacement is required.
- ★ If clearance is between 0.064 mm (0.025 in.) and the service limit (0.07 mm, 0.0031 in.), replace the bearing inserts [A] with inserts painted blue [B]. Check insert/journal clearance with the plastigage. The clearance may exceed the standard slightly, but it must not be less than the minimum in order to avoid bearing seizure.
- ★ If clearance exceeds the service limit, measure the diameter of the crankshaft main journal.

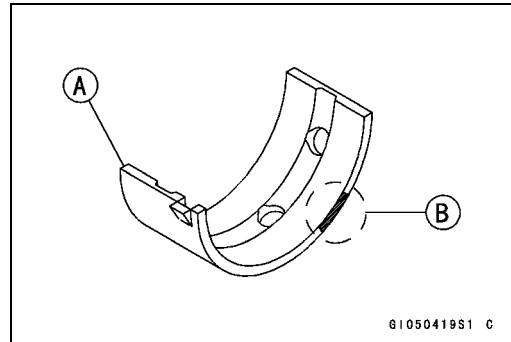

Crankshaft Main Journal Diameter

Standard: 36.984 ~ 37.000 mm (1.4561 ~ 1.4567 in.)

Service Limit: 36.96 mm (1.455 in.)

- ★ If any journal has worn past the service limit, replace the crankshaft with a new one.
- ★ If the measured journal diameters are not less than the service limit, but do not coincide with the original diameter markings on the crankshaft, make new marks on it.

Crankshaft Main Journal Diameter Marks

None 36.984 ~ 36.992 mm (1.4561 ~ 1.4564 in.)

1 36.993 ~ 37.000 mm (1.45641 ~ 1.4567 in.)

- : Crankshaft Main Journal Diameter Marks, "1" mark or no mark.

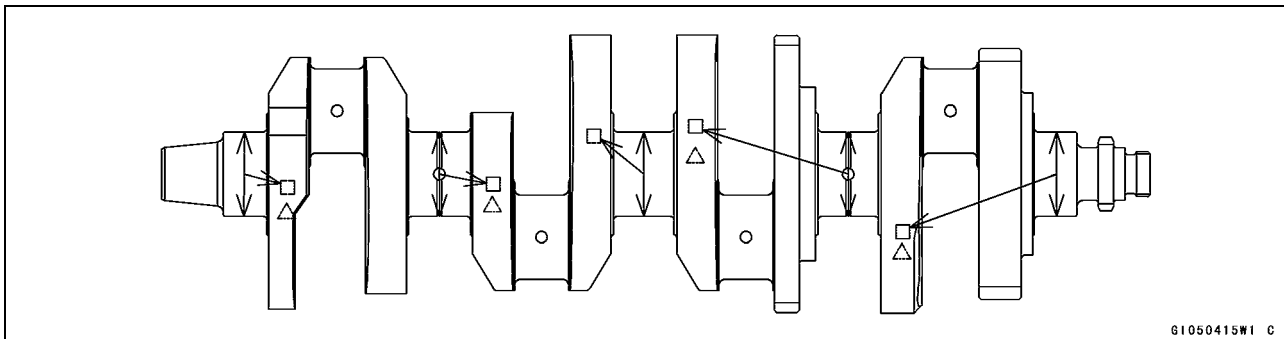

Crankshaft and Connecting Rods

- Measure the main bearing bore diameter, and mark [B] the upper crankcase half [A] in accordance with the bore diameter.
- Crankcase main bearing bore diameter marks are "○" mark and no mark.

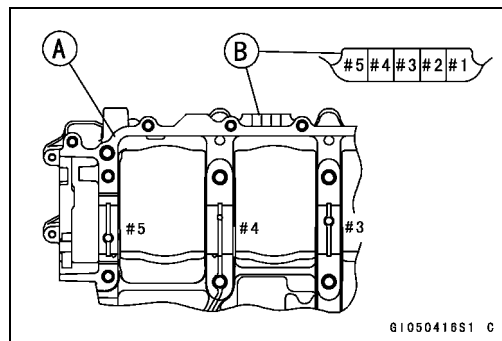

NOTE

- Tighten the crankcase bolts to the specified torque (see Crankcase Assembly).
- The mark already on the upper crankcase half should almost coincide with the measurement.

Crankcase Main Bearing Bore Diameter Marks

- **40.000 ~ 40.008 mm (1.5748 ~ 1.5751 in.)**
- None 40.009 ~ 40.016 mm (1.5752 ~ 1.5754 in.)**
- Select the proper bearing insert in accordance with the combination coding of the crankcase and crankshaft.
- Install the new inserts in the crankcase halves and check insert/journal clearance with the plastigage.

Crankcase Main Bearing Bore Diameter Marking	Crankshaft Main Journal Diameter Marking	Bearing Insert*		
		Size Color	Part Number	Journal Nos.
○	1	Brown	92028-1997	1, 5
			92139-1055	3
			92139-1052	2, 4
○	None	Black	92028-1996	1, 5
			92139-1054	3
None	1		92139-1051	2, 4
			92028-1995	1, 5
None	None	Blue	92139-1053	3
			92028-1998	2, 4

*The bearing inserts for Nos. 2, 3 and 4 journals have an oil groove, respectively.

Crankshaft Side Clearance

- Situate the motorcycle so that it is perpendicular to the ground.
- Insert a thickness gauge between the crankcase main bearing [A] and the crank web [B] at the No. 2 journal to determine clearance.
- ★ If the clearance exceeds the service limit, replace the crankcase halves as a set.

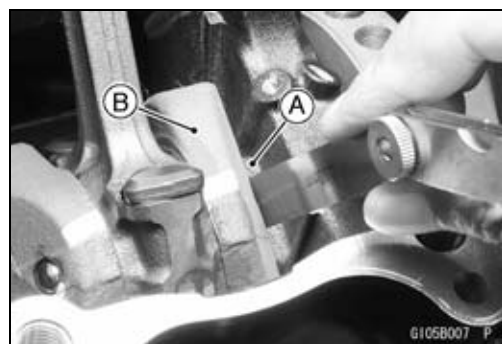

CAUTION

The upper and lower crankcase halves are machined at the factory in the assembled state, so the crankcase halves must be replaced as a set.

Crankshaft Side Clearance

- Standard: 0.05 ~ 0.20 mm (0.0020 ~ 0.0079 in.)**
- Service Limit: 0.40 mm (0.016 in.)**

9-18 CRANKSHAFT/TRANSMISSION

Crankshaft and Connecting Rods

Crankshaft Runout

- Measure the crankshaft runout.
- ★ If the measurement exceeds the service limit, replace the crankshaft.

Crankshaft Runout

Standard: TIR 0.03 mm (0.0012 in.) or less

Service Limit: TIR 0.07 mm (0.0028 in.)

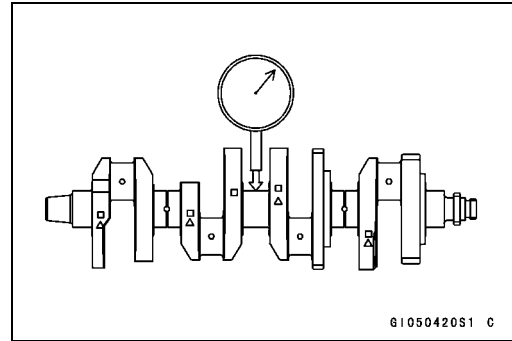

Balancer

Balancer Removal

- Split the crankcase (see Crankcase Splitting).
- Remove:
 - Crankshaft
 - Driveshaft
- Unscrew the balancer shaft clamp bolt [A], and balancer shaft clamp lever bolt [B], and pull off the clamp lever [C].
- Pull the balancer shaft [D] out of the crankcase. The balancer weight and gear assembly [E] come off with the needle bearings and copper washers.

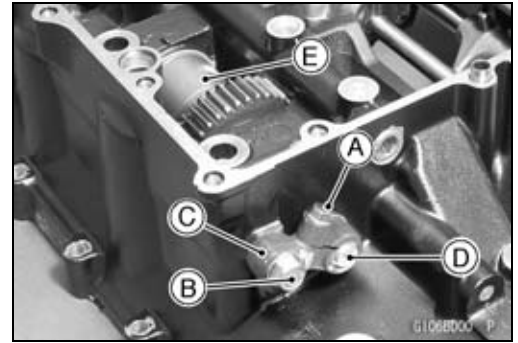

Balancer Installation

- Check that the rubber dampers [A] are in place as shown.

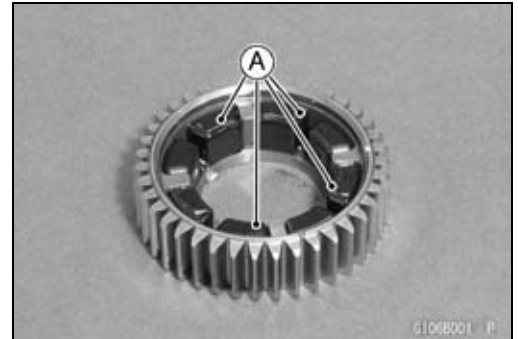

- Apply molybdenum disulfide oil solution to the damper contact portions of the balancer weight.
- Install the balancer weight [A] into the gear [B].
- Align the mark [C] of the balancer weight to the groove [D] of the gear.

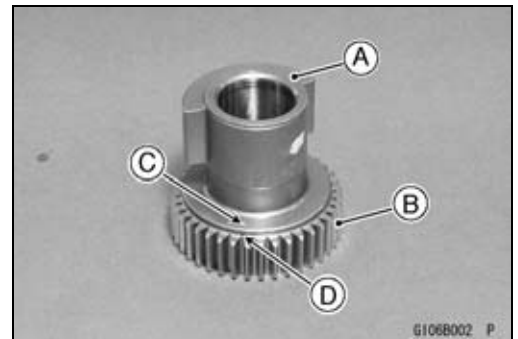

- Apply molybdenum disulfide oil solution to the needle bearings. Insert the needle bearings.
- Fit the copper washers [A] on both ends of the weight and gear assembly. The projected sides [B] face inward.
- Set the weight and gear assembly to the Lower Crankcase.

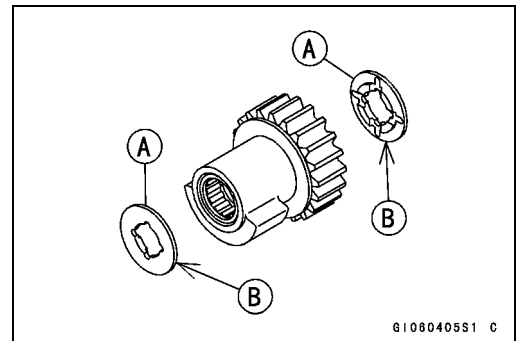

- Apply engine oil to the O-ring of the balancer shaft.
- Insert the balancer shaft.
- Turn the balancer shaft, so the punch mark [A] comes toward the oil pan [B], and then install the clamp lever [C].
- Tighten the balancer shaft lever bolt [D] and tighten the clamp bolt [E].

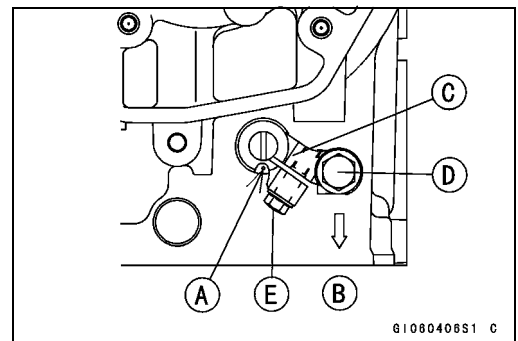

Torque - Balancer Shaft Clamp Lever Bolt: 25 N·m (2.5 kgf·m, 18 ft·lb)

Balancer Shaft Clamp Bolt: 12 N·m (1.2 kgf·m, 106 in·lb)

9-20 CRANKSHAFT/TRANSMISSION

Balancer

- Position the crankshaft at #1, 4 position TDC.
- Fit the lower crankcase to the upper crankcase aligning the punch mark [A] on the balancer weight with the projection [B] of the lower crankcase.

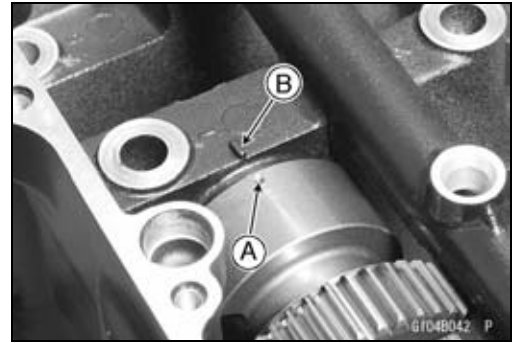

- Adjust the balancer gear backlash with the engine idling. The amount of backlash can be changed by turning the balancer shaft which has eccentric journals.
- Remove the right lower fairing (see Frame chapter).
- Start the engine and let it idle.
- Loosen the clamp bolt [A] and turn the balancer shaft [B] clockwise [C] until the balancer gear makes a whining sound.
- Turn the shaft counter-clockwise [D] until the balancer gear whining sound disappears and tighten the clamp bolt.

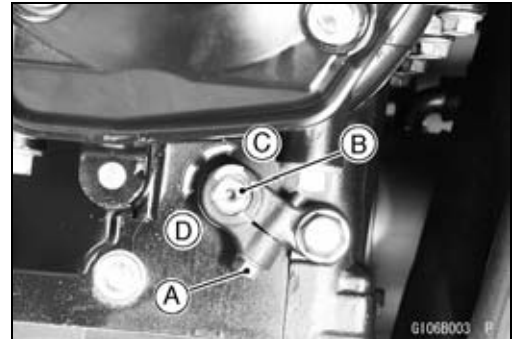

Torque - Balancer Shaft Clamp Bolt: 12 N·m (1.2 kgf·m, 106 in·lb)

Balancer Damper Inspection

- Remove the balancer and disassemble the weight and gear assembly.
- Visually inspect the rubber dampers [A].
- ★ If they appear damaged or deteriorated, replace them.

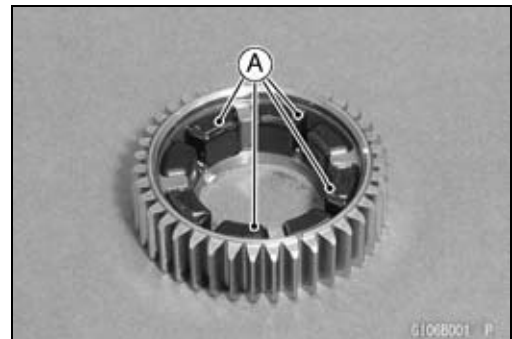

Starter Motor Clutch and Torque Limiter

Starter Motor Removal/Installation

- Refer to the Alternator Rotor Removal and Installation in the Electrical System chapter.

Starter Motor Clutch Removal

- Split the crankcase (see Crankcase Splitting).
- Remove:
 - Transmission Shafts
 - Crankshaft
- Unscrew the starter clutch shaft plate bolt [A].
- Pull the starter clutch shaft bolt [C] with the stopper plate [D] and starter clutch shaft holding the starter clutch [B].
- Remove the starter clutch.

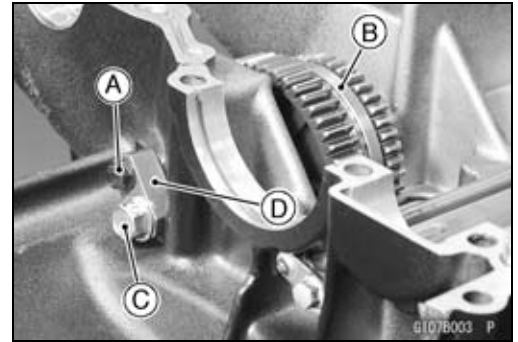

Starter Motor Clutch Installation

- Apply engine oil to the needle bearing.
- Install:
 - Coller (Long) [A]
 - Starter Motor Clutch [B]
 - Coller (Short) [C]
 - Starter Motor Clutch Shaft [D]
- Apply molybdenum disulfide grease to the starter motor clutch shaft.
- Apply a non-permanent locking agent to the threads of the starter clutch shaft plate bolt, and tighten it.

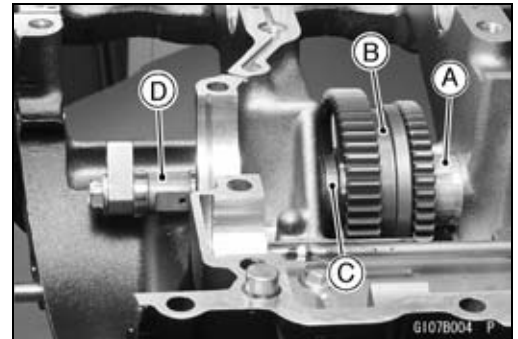

Torque - Starter Clutch Shaft Plate Bolt: 12 N·m (1.2 kgf·m, 106 in·lb)

- ★ If the shaft bolt removed, tighten it.
- Apply a non-permanent locking agent to the threads of the shaft bolt.

Torque - Starter Clutch Shaft Bolt: 25 N·m (2.5 kgf·m, 18 ft·lb)

Starter Motor Clutch Disassembly

- Remove the starter motor clutch.
- Pull the driven gear out off from the drive gear.
- Remove:
 - Circlip [A]
 - Flat Washer [B]

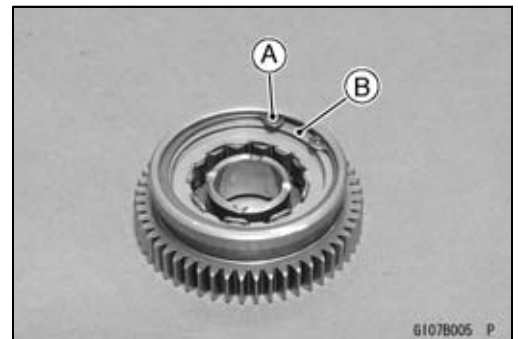

9-22 CRANKSHAFT/TRANSMISSION

Starter Motor Clutch and Torque Limiter

- Holding the drive gear [A] with a hand, take off the one-way clutch [B] from the gear by using the screw driver [C].

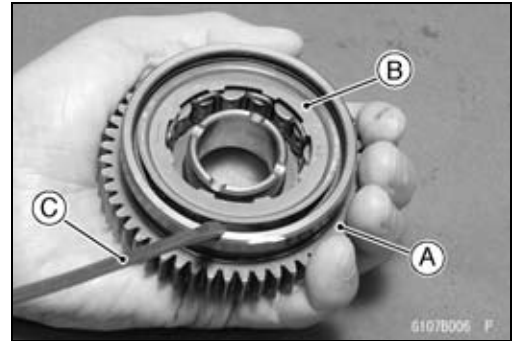

Starter Motor Clutch Assembly

- Be sure to install the one-way clutch [A] so that its flange [B] fits in the holder recess [C].

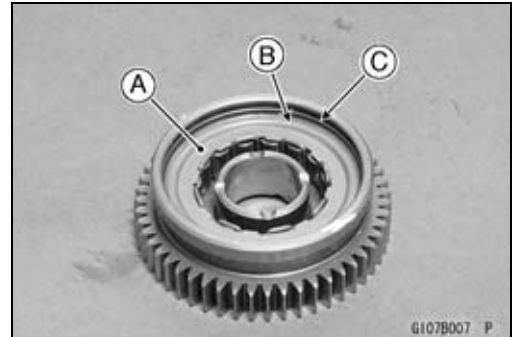

- Turn in the driven gear [A] to the drive gear [B]. Counterclockwise [C]

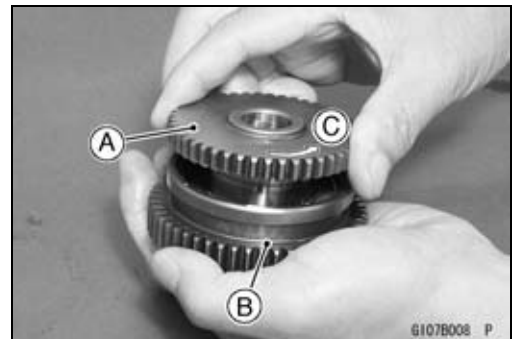

Starter Clutch Inspection

- Remove the engine (see Engine Removal/Installation chapter).
- Remove:
 - Cooling Hose Fitting (see Cooling System chapter)
 - Starter Motor (see Electrical System chapter)
 - Bolts [A]
 - Torque Limiter Cover [B]

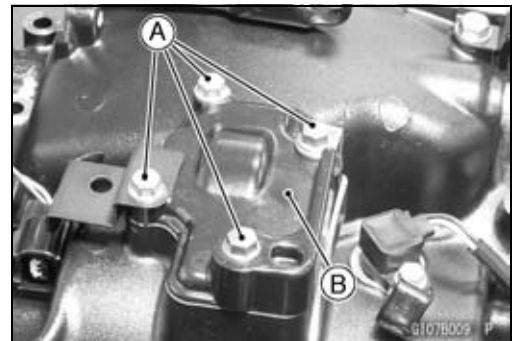

- Turn the starter idle gear [A] by hand. When viewed from the rear side of the engine, the starter idle gear should turn forward [B] freely, but should not turn backward [C].
- ★ If the clutch does not operate as it should or if it makes noise, disassemble the starter clutch, examine each part visually, and replace any worn or damaged parts.

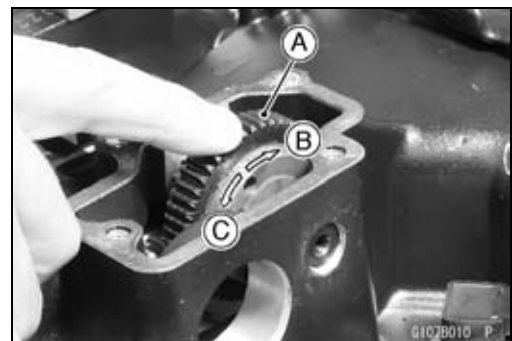

Starter Motor Clutch and Torque Limiter

Torque Limiter Removal

- Remove:
 - Starter Motor (see Electrical System chapter)
 - Torque Limiter Cover (see Starter Motor Clutch Inspection)
- Using the 5 mm (0.20 in.) bolt [A], pull out the torque limiter shaft [B].
- Remove the torque limiter [C].

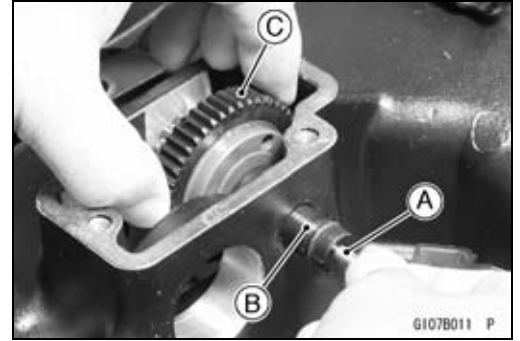

Torque Limiter Installation

- Inspect the O-ring, and replace it if it is damaged.
- Apply engine oil to the O-ring.
- Apply molybdenum disulfide grease to the torque limiter shaft.
- Install the torque limiter cover bolts with clamps [A] as shown.
- Apply a non-permanent locking agent to the bolts.

Torque - Torque Limiter Cover Bolts: 12 N·m (1.2 kgf·m, 106 in·lb)

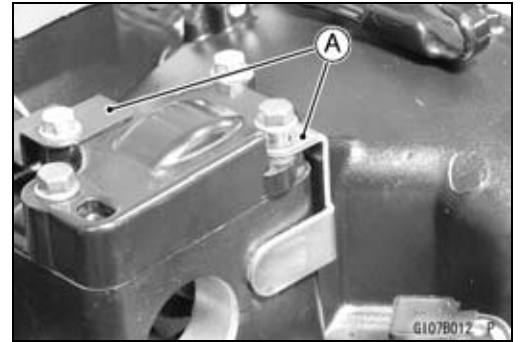

9-24 CRANKSHAFT/TRANSMISSION

Transmission

Shift Pedal Removal

- Mark [A] the position of the shift lever [B] on the shift shaft so that it can be installed later in the same position.
- Remove:
 - Bolt [C]
 - Shift Lever

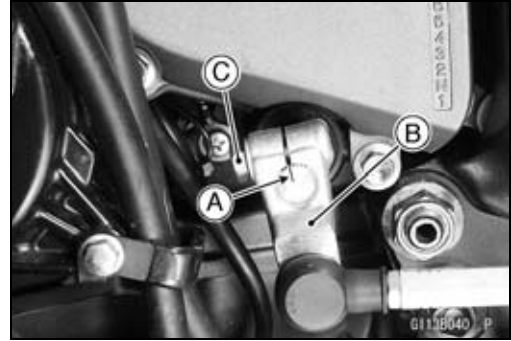

- Remove the bolt [A], and shift pedal [B].

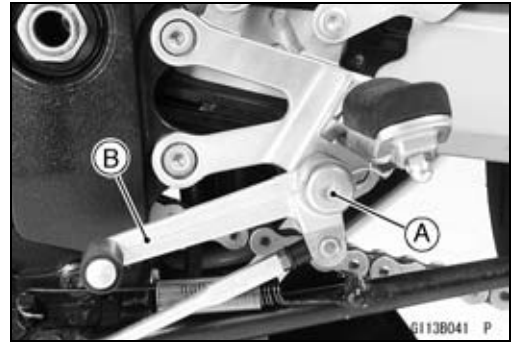

Shift Pedal Installation

- Apply grease to install the oil seals [A] direction as shown.
- Apply grease [B] to the bearing portion of the shift pedal mounting bolt [C].
 - Washer [D]
 - Shift Pedal [E]

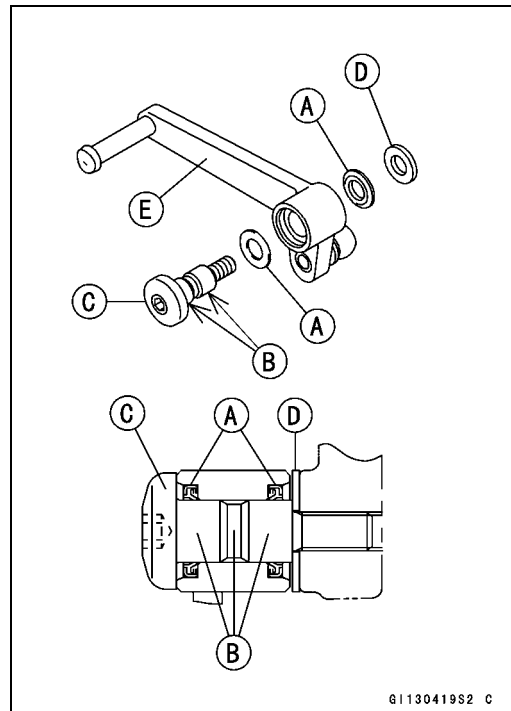

- Install the shift pedal [A] so that the center of the shift pedal front end [B] is aligned with the center line [C] of the shift rod [D] by loosening the front and rear locknuts [E], and turning the rod.

NOTE

○ The locknut next to the knurled portion of the rod has left-hand threads.

- ★ If necessary, adjust the pedal position from the standard position to suit you as follows.
 - Loosen the front and rear rod locknuts.
 - Turn the rod to adjust the pedal position.
 - Tighten the locknuts securely.

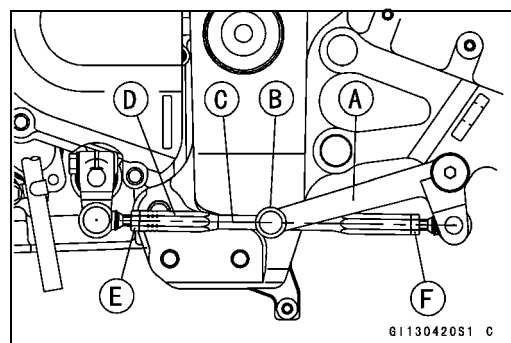

Transmission

External Shift Mechanism Removal

- Squeeze the brake lever slowly and hold it with a band [A].

⚠ WARNING

Be sure to hold the front brake when removing the engine, or the motorcycle, may fall over. If could cause an accident and injury.

CAUTION

Be sure to hold the front brake when removing the engine, or the motorcycle may fall over. The engine or the motorcycle could be damaged.



- Remove:
 - Engine Oil (drain, see Engine Oil Change in the Periodic Maintenance chapter)
 - Shift Pedal (see Shift Pedal Removal)
 - Clutch (see Clutch chapter)
 - Bolts [A], Oil Pipe Holders [B], Oil Pipe [C] with O-ring

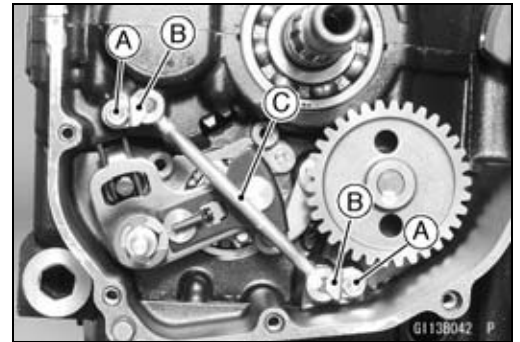

- Remove the shift shaft assembly [A] while pulling the shift mechanism arm [B] to the direction of the arrow.



- Remove the oil pump drive gear [A] initially if removing the gear positioning lever [B] (see Engine Lubrication System chapter).
- Remove:
 - Bolt [C]
 - Gear Positioning Lever [B]
 - Spring [D]

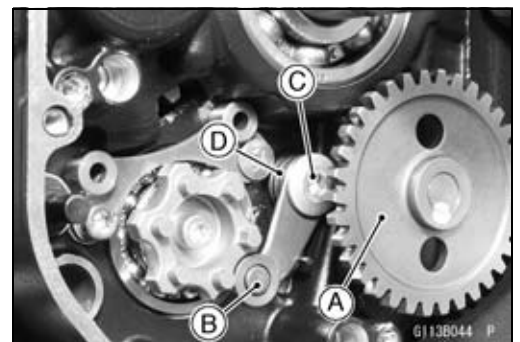

9-26 CRANKSHAFT/TRANSMISSION

Transmission

External Shift Mechanism Installation

- Replace the circlip that was removed with a new one and install the shift mechanism arm.
- Install the gear positioning lever [A] as shown.
 - Spring [B]
 - Collar [C]
 - Bolt [D]
- Apply a non-permanent locking agent to the bolt and tighten it.

Torque - Gear Positioning Lever Bolt: 10 N·m (1.0 kgf·m, 89 in·lb)

- Apply engine oil to the O-rings to install the oil pipe.
- Apply a non-permanent locking agent to the oil pipe holder bolts and tighten them.

Torque - Oil Pipe Holder Bolts: 12 N·m (1.2 kgf·m, 106 in·lb)

External Shift Mechanism Inspection

- Examine the shift shaft [A] for any damage.
 - ★ If the shaft is bent, straighten or replace it.
 - ★ If the serration are damaged, replace the shaft.
 - ★ If the springs [B], [C] are damaged in any way, replace them.
 - ★ If the shift mechanism arm [D] is damaged in any way, replace the arm.

- Check the return spring pin [A] is not loose.
 - ★ If it is loose, unscrew it, apply a non-permanent locking agent to the threads, and tighten it.

Torque - Shift Shaft Return Spring Pin: 30 N·m (3.0 kgf·m, 22 ft·lb)

- Check the gear positioning lever [B] and it spring for breaks or distortion.
 - ★ If the lever or spring are damaged in any way, replace them.
- Visually inspect the shift drum cam [C].
 - ★ If they are badly worn or if they show any damage, replace it.

Transmission Shaft Removal

- Split the crankcase (see Crankcase Splitting).
- Remove the drive shaft [A] and output shaft [B].

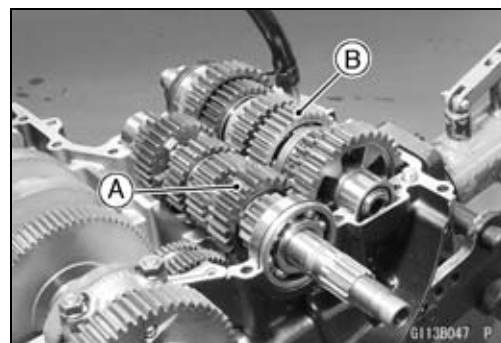
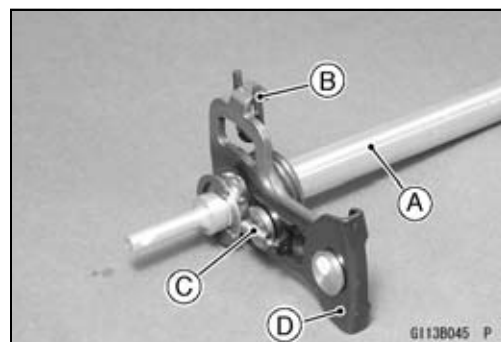
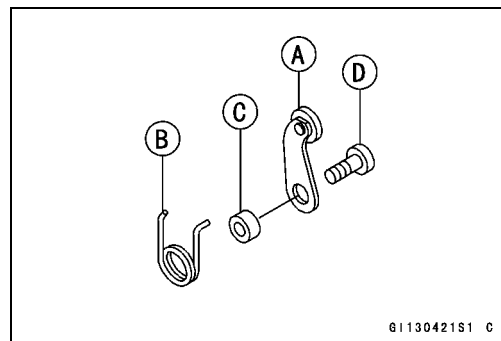

Transmission

Transmission Shaft Installation

- Apply engine oil to the sliding surfaces of the shafts, gears and bearings.
- Check to see that the set pins [A] and set rings [B] are in place.

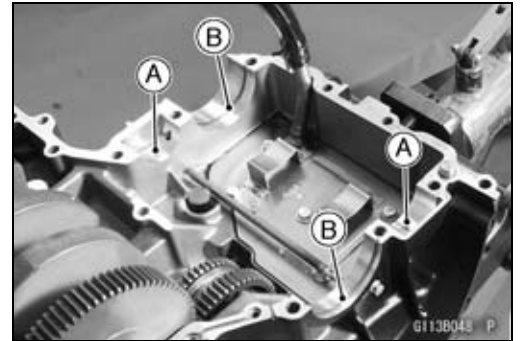

- Install the drive shaft and output shaft into the upper crankcase half.
- Install the output shaft [A] first.

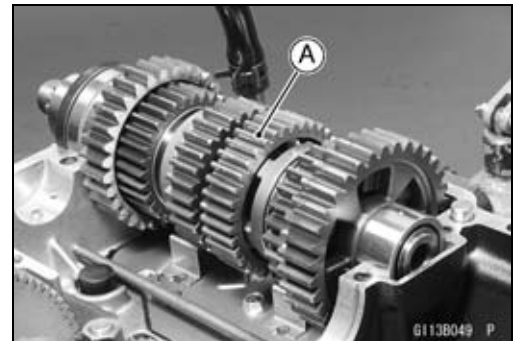

- The bearing set pins and rings must match properly with the holes or grooves in the bearing outer races. When they are properly matched, there is no clearance between the crankcase and the bearing outer races [A].



- Assemble the crankcase.
- Press in the oil seal [A] onto collar [B] so that the surface [C] of the oil seal is flush with the counterbore bottom surface [D] of the crankcase.

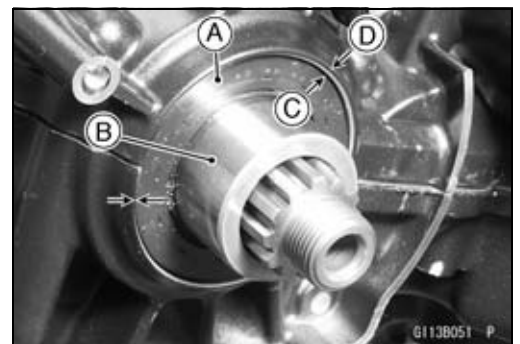

Transmission Disassembly

- Remove the transmission shafts (see Transmission Shaft Removal).
- Remove the circlips, disassemble the transmission shafts.

Special Tool - Outside Circlip pliers: 57001-144

- The 5th gear [A] on the output shaft has three steel balls assembled into it for the positive neutral finder mechanism. Remove the 5th gear.
- Set the output shaft in a vertical position holding the 3rd gear [B].
- Spin the 5th gear quickly [C] and pull it off upward.

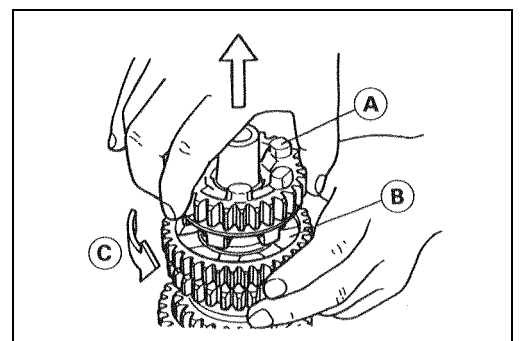

9-28 CRANKSHAFT/TRANSMISSION

Transmission

- Remove the ball bearing [A] from each shafts.
Special Tools - Bearing Puller: 57001-135 [B]
Bearing Puller Adapter: 57001-317 [C]
- Discard the bearing.

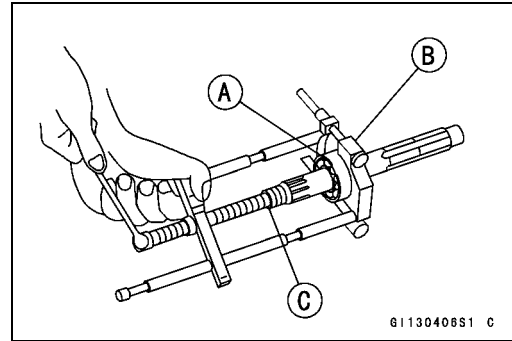

Transmission Assembly

- Apply engine oil to the ball bearing and shaft.
 - Drive the ball bearing onto the drive shaft [A] with the groove [B] facing the clutch.
 - Drive the ball bearing onto the output shaft.
- Special Tool - Steering Stem Bearing Driver: 57001-137**

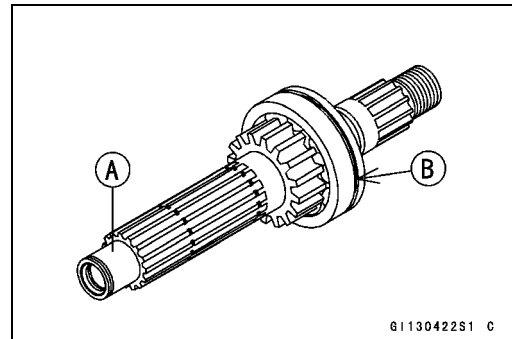

- Align the bushing-oil holes [B] with the shaft-oil holes to install the gear bushings [A].

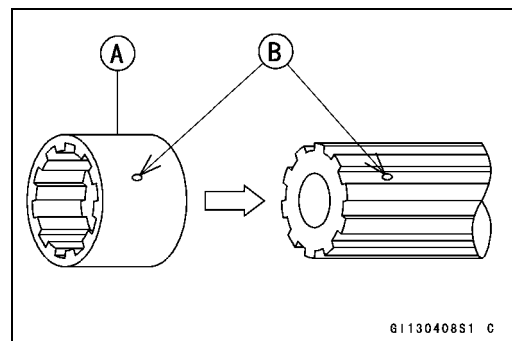

- Replace any circlip that were removed with new ones.
- Install the circlips [A] so that the opening [B] is aligned with a spline groove [C].
- Check that each gear spins or slides freely on the transmission shafts without binding after assembly.

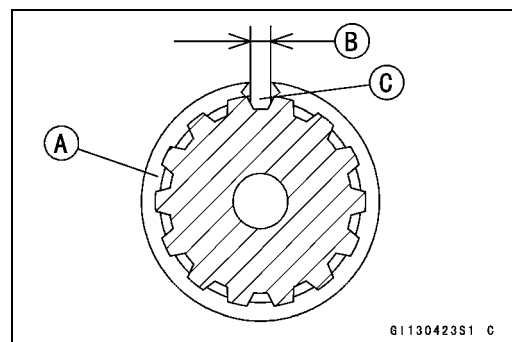

- The drive shaft gears can be recognized by size: the gear with the smallest diameter is 1st gear, and the largest one is 6th gear. Be sure that all parts are put back in the correct sequence and all circlips and washers are properly in place.
- Install the 3rd/4th gear onto the drive shaft with their oil holes aligned.

Transmission

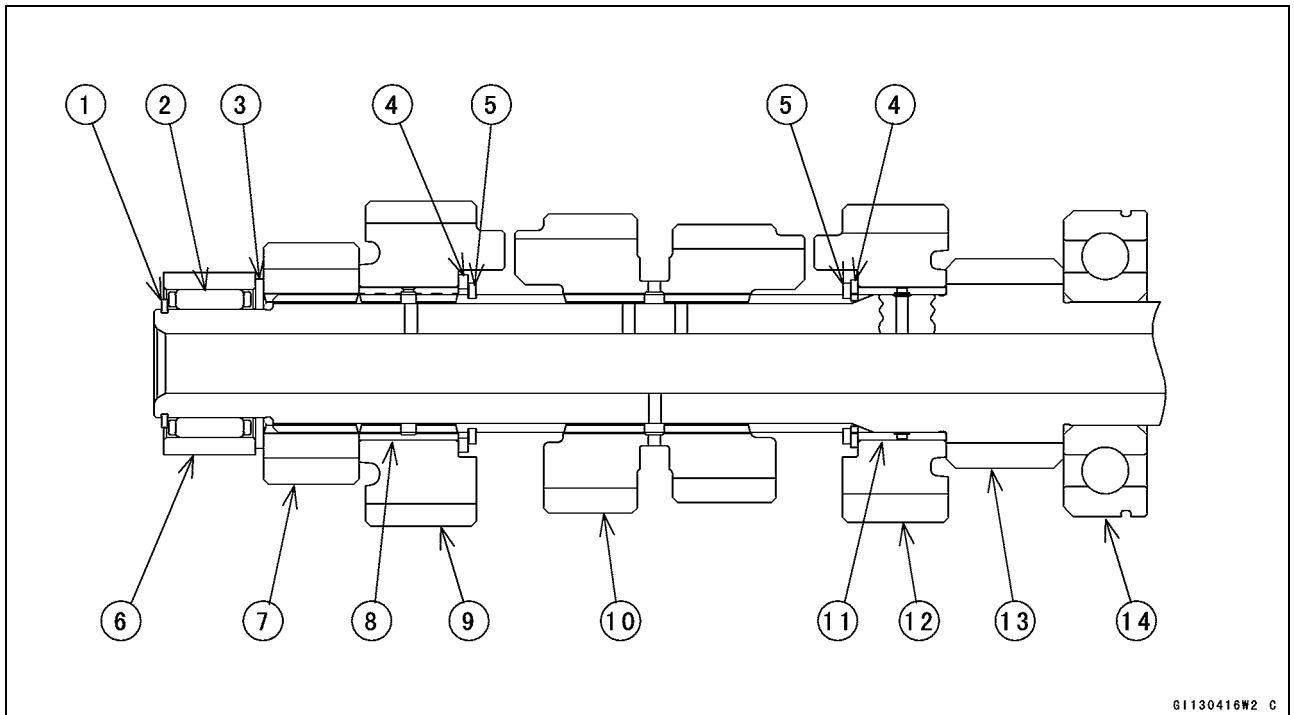

- | | | |
|--------------------|---------------------|-------------------------------|
| 1. Circlip (small) | 6. Outer Race | 11. Bushing |
| 2. Needle Bearing | 7. 2nd Gear | 12. 5th Gear |
| 3. Washer (big) | 8. Bushing (Spline) | 13. Drive Shaft with 1st Gear |
| 4. Washers (small) | 9. Top Gear | 14. Ball Bearing |
| 5. Circlips (big) | 10. 3rd/4th Gear | |

- The output shaft gears can be recognized by size: the gear with the largest diameter is 1st gear, and the smallest one is 6th gear. Be sure that all parts are put back in the correct sequence and all circlips and washers are properly in place.
- Install the 5th and 6th gear onto the output shaft with their oil holes aligned as shown.
- Apply molybdenum disulfide grease to both surfaces of the No.18 washers (see 9-30 page).

9-30 CRANKSHAFT/TRANSMISSION

Transmission

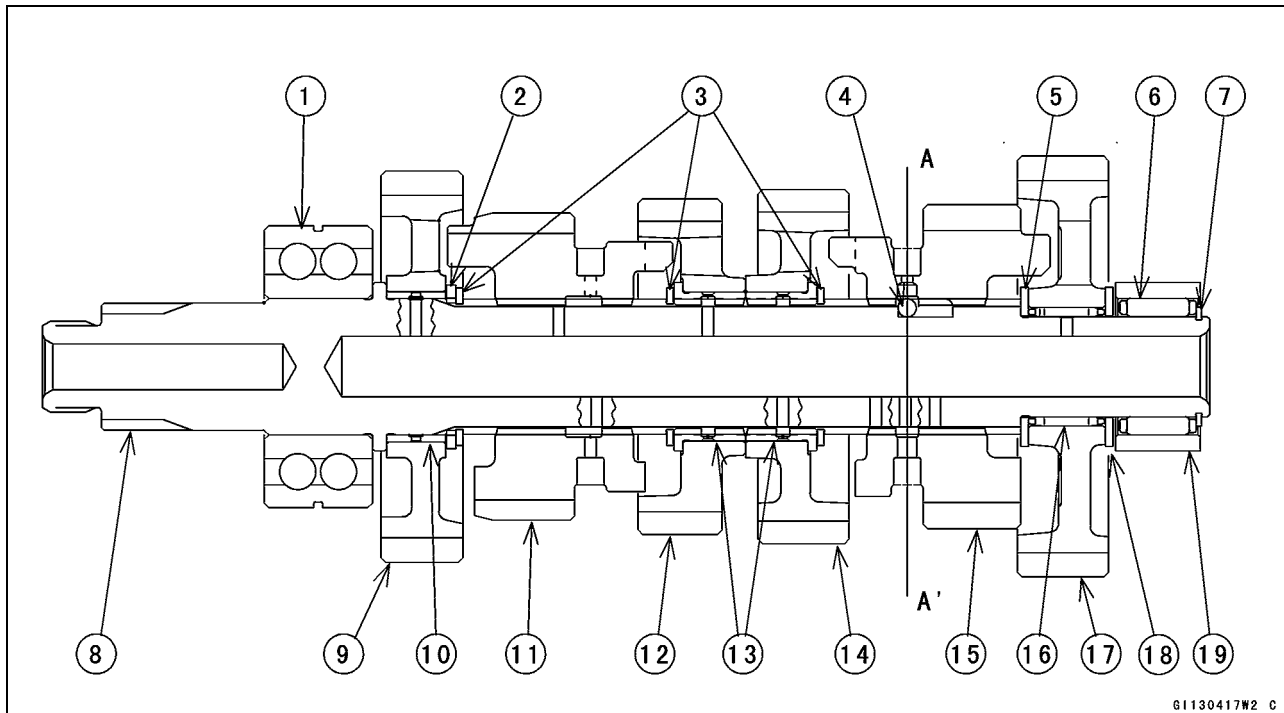

- | | | |
|-------------------|-----------------|--------------------|
| 1. Ball Bearing | 8. Output Shaft | 15. 5th Gear |
| 2. Washer | 9. 2nd Gear | 16. Needle Bearing |
| 3. Circlips | 10. Bushing | 17. 1st Gear |
| 4. Steel Balls | 11. Top Gear | 18. Washer |
| 5. Washer | 12. 4th Gear | 19. Outer Race |
| 6. Needle Bearing | 13. Bushings | |
| 7. Circlip | 14. 3rd Gear | |

- Fit the steel balls into the 5th gear holes as shown.
View A-A' (see the output shaft illustration)
Gear (5th) [A]
Shaft [B]
Steel Balls [C]

CAUTION

Do not apply grease to the steel balls to hold them in place. This will cause the positive neutral finder mechanism to malfunction.

- Check the ball-locking effect that the 5th gear does not come out of the output shaft when moving it up and down by hand.

Shift Drum and Fork Removal

- Remove:
 - Lower Fairings (see Frame chapter)
 - Muffler (see Engine Top End chapter)
 - Oil Pan (see Engine Lubrication System chapter)
 - Oil Pump Drive Gear (see Engine Lubrication System chapter)
 - External Shift Mechanism (see External Shift Mechanism Removal)
 - Gear Position Switch (see Fuel System (DFI) chapter)
 - Gear Positioning Lever (see External Shift Mechanism Removal)
 - Bolt [A] and Screw [B]

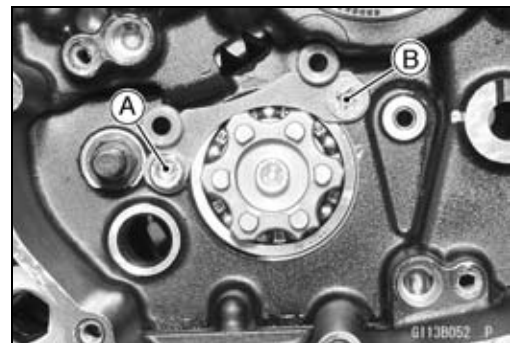
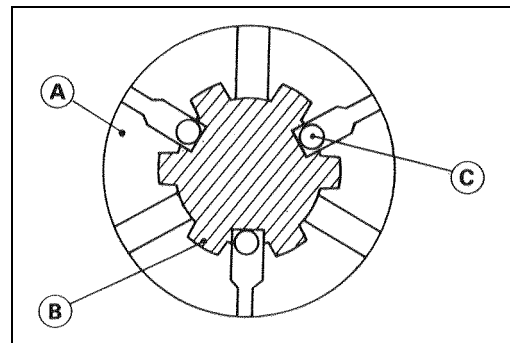

Transmission

- Pull the shift rods [A] with the shift drum bearing holder [B] on, and take off the bearing holder and shift forks.
- Pull out the shift drum [C] with the ball bearing [D].

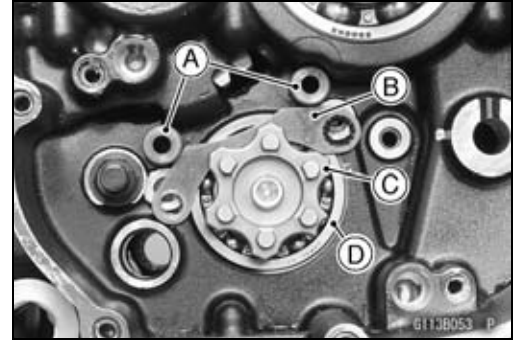

Shift Drum and Fork Installation

- Insert the shift drum.
- Insert the shift forks into both grooves of the gears and shift drum, and install the shift rods [A]. The shift rods [A] are identical.
 - Drive Shaft Shift Fork [B]
 - Output Shaft Forks with same shape and size [C]
- Install each fork so that number-marked side faces right side of the engine.

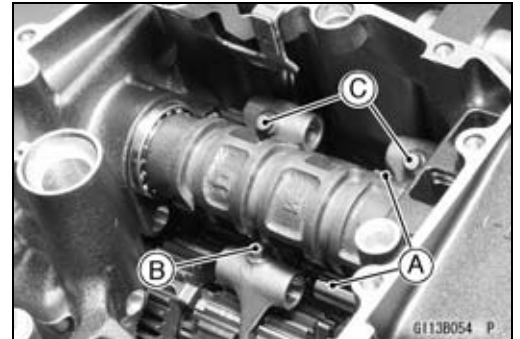

Drive Shaft Fork marked with "290" [A]
Output Shaft Forks marked with "291" [B]

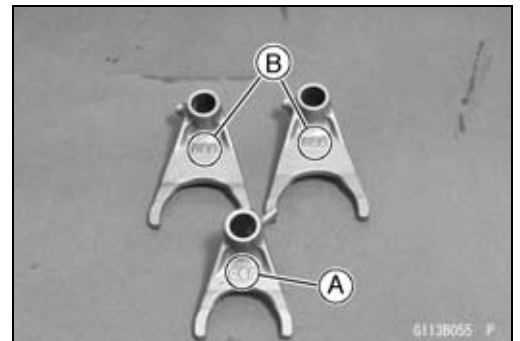

- Insert the bearing holder [B] to the shift fork rods [A] as shown.
- Apply a non-permanent locking agent to the threads of the shift drum bearing holder bolt and screw, and tighten them.

Torque - Shift Drum Bearing Holder Bolt: 12 N·m (1.2 kgf·m, 106 in·lb)
Shift Drum Bearing Holder Screw: 5.4 N·m (0.55 kgf·m, 48 in·lb)

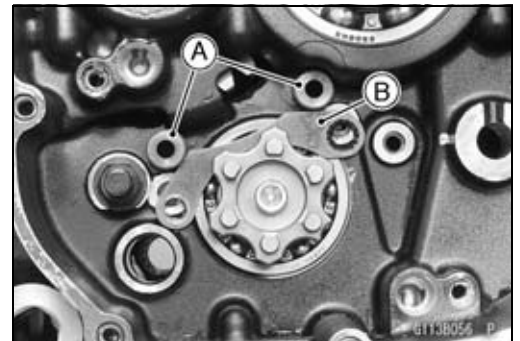

Shift Drum Disassembly

- Remove the shift drum (see Shift Drum and Fork Removal).
- While holding the shift drum with a vise, remove the shift drum cam holder bolt.
 - Shift Drum Cam Holder Bolt [A]
 - Shift Drum Cam [B]
 - Ball Bearing [C]

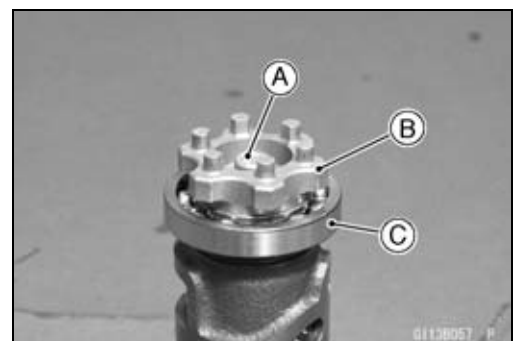

9-32 CRANKSHAFT/TRANSMISSION

Transmission

Shift Drum Assembly

- Be sure to install the dowel pin [A].
- Align the dowel pin with the hole [B] of the shift drum cam holder.
- Apply a non-permanent locking agent to the threads of the shift drum cam bolt, and tighten it.

Torque - Shift Drum Cam Bolt: 12 N·m (1.2 kgf·m, 106 in·lb)

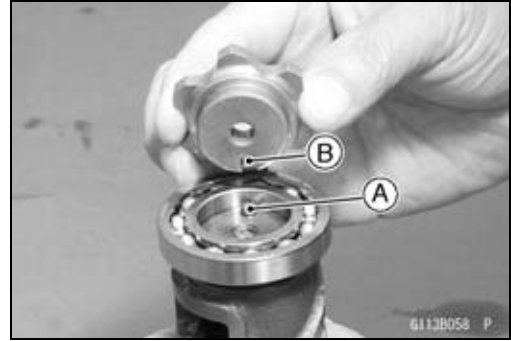

Shift Fork Bending

- Visually inspect the shift forks, and replace any fork that is bent. A bent fork could cause difficulty in shifting, or allow the transmission to jump out of gear when under power. 90° [A]

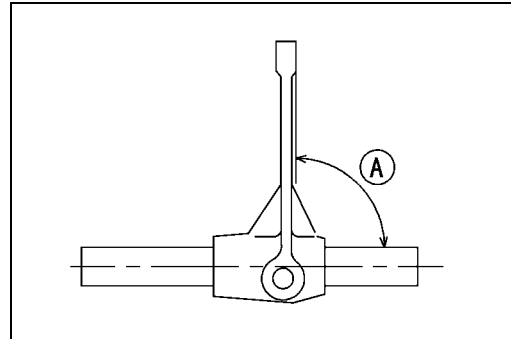

Shift Fork/Gear Groove Wear

- Measure the thickness of the shift fork ears [A], and measure the width [B] of the gear grooves.
- ★ If the thickness of a shift fork ear is less than the service limit, the shift fork must be replaced.

Shift Fork Ear Thickness

Standard: 5.9 ~ 6.0 mm (0.232 ~ 0.236 in.)

Service Limit: 5.8 mm (0.228 in.)

- ★ If the gear groove is worn over the service limit, the gear must be replaced.

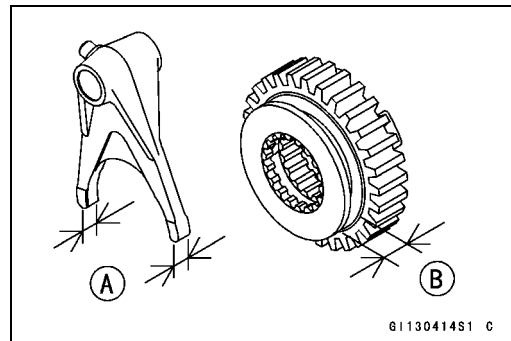

Gear Groove Width

Standard: 6.05 ~ 6.15 mm (0.238 ~ 0.242 in.)

Service Limit: 6.25 mm (0.246 in.)

Shift Fork Guide Pin/Drum Groove Wear

- Measure the diameter of each shift fork guide pin [A], and measure the width [B] of each shift drum groove.
- ★ If the guide pin on any shift fork is less than the service limit, the fork must be replaced.

Shift Fork Guide Pin Diameter

Standard: 6.9 ~ 7.0 mm (0.272 ~ 0.276 in.)

Service Limit: 6.8 mm (0.268 in.)

- ★ If any shift drum groove is worn over the service limit, the drum must be replaced.

Shift Drum Groove Width

Standard: 7.05 ~ 7.20 mm (0.278 ~ 0.283 in.)

Service Limit: 7.3 mm (0.287 in.)

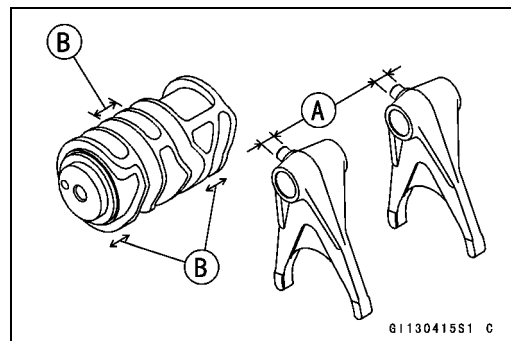

Transmission

Gear Dog and Gear Dog Hole Damage

- Visually inspect the gear dogs [A] and gear dog holes [B].
- ★ Replace any damaged gears or gears with excessively worn dogs or dog holes.

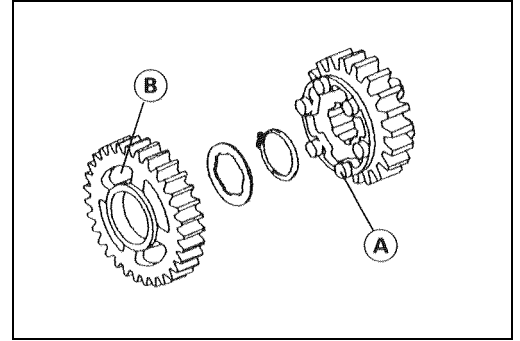

Wheels/Tires

Table of Contents

Exploded View	10-2
Specifications	10-3
Wheels (Rims)	10-4
Front Wheel Removal	10-4
Front Wheel Installation	10-4
Rear Wheel Removal	10-6
Rear Wheel Installation	10-7
Wheel Inspection	10-8
Axle Inspection	10-9
Balance Inspection	10-9
Balance Adjustment	10-9
Balance Weight Removal	10-10
Balance Weight Installation	10-10
Tires	10-12
Air Pressure Inspection/Adjustment	10-12
Tire Inspection	10-12
Tire Removal	10-12
Tire Installation	10-13
Repair	10-15
Hub Bearings	10-16
Hub Bearing Removal	10-16
Hub Bearing Installation	10-16
Hub Bearing Inspection	10-16

10-2 WHEELS/TIRES

Exploded View

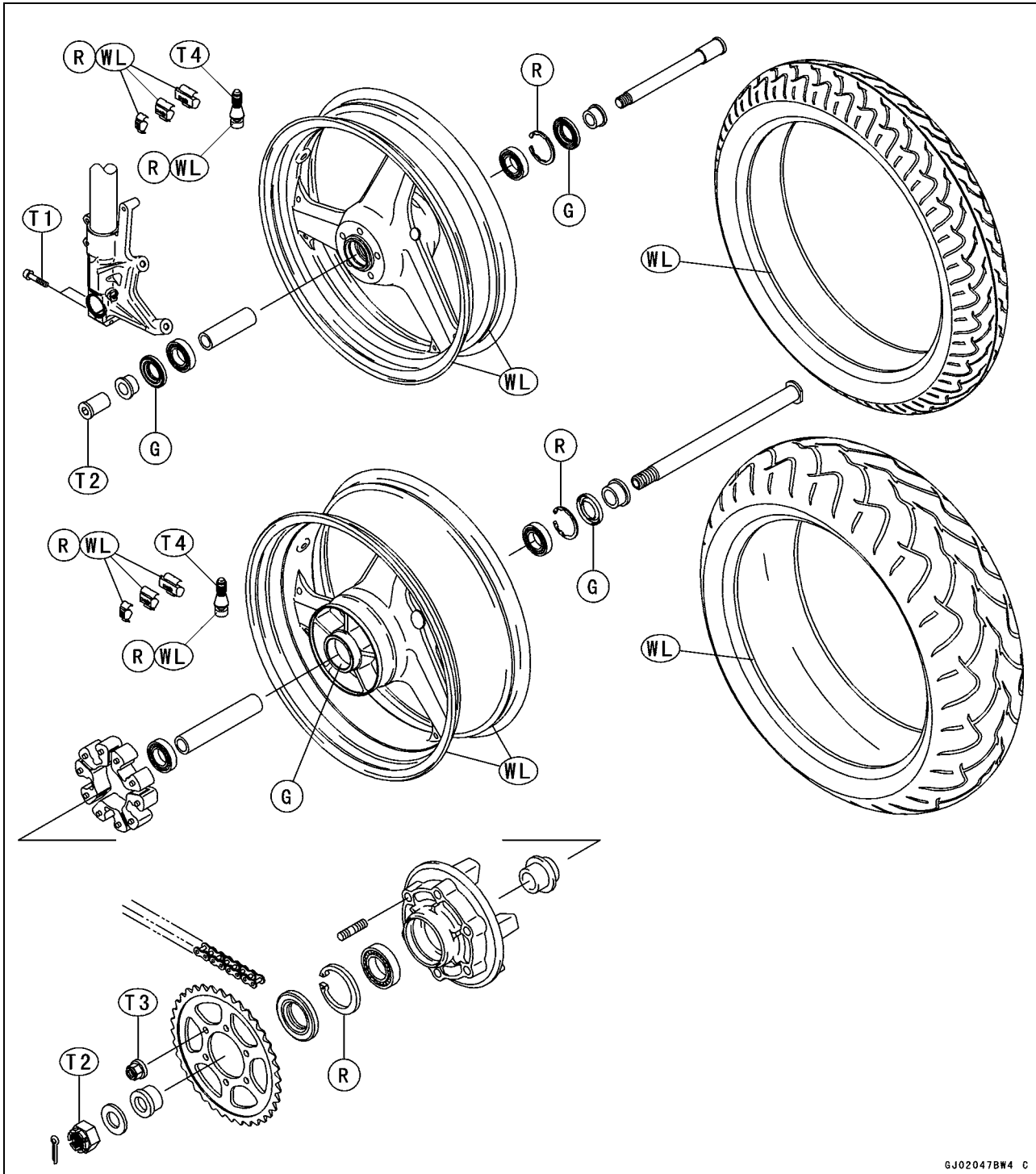

GJ02047BW4 C

T1: 20 N·m (2.0 kgf·m, 15 ft·lb)

T2: 125 N·m (13 kgf·m, 92 ft·lb)

T3: 59 N·m (6.0 kgf·m, 44 ft·lb)

T4: 0.15 N·m (0.015 kgf·m, 1.3 in·lb)

G: Apply grease.

R: Replacement Parts

WL: Apply soap and water solution or rubber lubricant.

Specifications

Item	Standard	Service Limit
Wheels (Rims)		
Rim Runout:		
Axial	---	0.5 mm (0.02 in.)
Radial	---	0.8 mm (0.03 in.)
Axle Runout/100 mm (3.94 in.)	0.05 mm (0.002 in.) or less	0.2 mm (0.008 in.)
Wheel Balance	10 g (0.35 oz) or less	---
Balance Weights	10 g (0.35 oz), 20 g (0.71 oz), 30 g (1.06 oz)	---
Tires		
Air Pressure (when Cold):		
Front	Up to 182 kg (401 lb) load: 290 kPa (2.90 kgf/cm ² , 42 psi)	---
Rear	Up to 182 kg (401 lb) load: 290 kPa (2.90 kgf/cm ² , 42 psi)	---
Tread Depth:		
Front	DUNLOP: 4.0 mm (0.16 in.)	1 mm (0.04 in.) (AT, CH,DE)
Rear	DUNLOP: 5.4 mm (0.21 in.)	1.6 mm (0.06 in.) Up to 130 km/h (80 mph): 2 mm (0.08 in.) Over 130 km/h (80 mph): 3 mm (0.12 in.)
Standard Tires:	Make, Type	Size
Front	DUNLOP, SPORTMAX RADIAL D208FJ (tubeless)	120/70 ZR17 M/C (58 W)
Rear	DUNLOP SPORTMAX RADIAL D208J (tubeless)	200/50 ZR17 M/C (75 W)

AT: Republic of Austria
 CH: Swiss Confederation
 DE: Federal Republic of Germany

- Special Tools - Inside Circlip Pliers: 57001-143**
- Bearing Driver Set: 57001-1129**
- Jack: 57001-1238**
- Bearing Remover Head, $\phi 25 \times \phi 28$: 57001-1346**
- Bearing Remover Shaft, $\phi 13$: 57001-1377**

10-4 WHEELS/TIRES

Wheels (Rims)

Front Wheel Removal

- Remove:
 - Lower Fairings (see Frame chapter)
 - Brake Caliper Mounting Bolts [A]
 - Refractors [B] (for the US and Canadian model)
 - ZX1200-B1/B2 [C]
 - ZX1200-B3 [D]

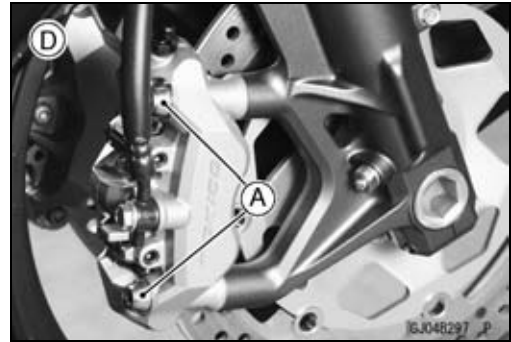
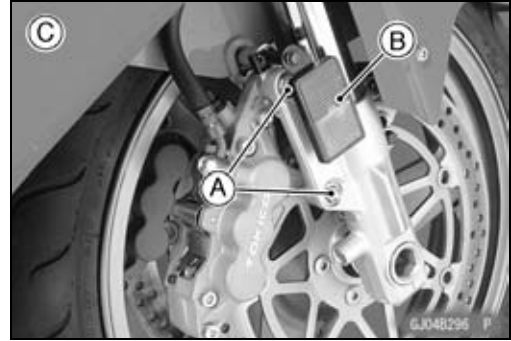

- Loosen:
 - Right Side Axle Clamp Bolts [A]
 - Axle [B]

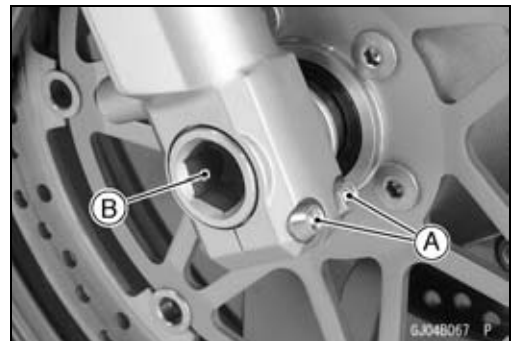

- Raise the front wheel off the ground.
 - Special Tool - Jack: 57001-1238 [A]**
- Pull out the axle to the right and drop the front wheel out of the forks.

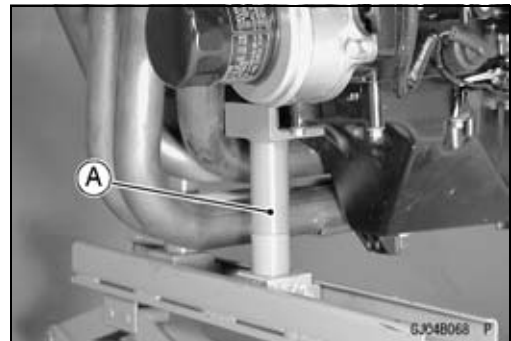

CAUTION

Do not lay the wheel down on one of the discs. This can damage or warp the disc. Place blocks under the wheel so that the disc does not touch the ground.

Front Wheel Installation

NOTE

○The direction of the wheel rotation [A] is shown by an arrow [B] on the wheel spoke.

- Check the wheel rotation mark on the front wheel and install it.
- Fit the collars on the both sides of the hub.
- The collars are identical.
- If the axle nut in the left fork leg is removed, install it on the left fork leg from the left side.
- Tighten the axle nut.

Torque - Front Axle Nut: 125 N·m (13 kgf·m, 92 ft·lb)

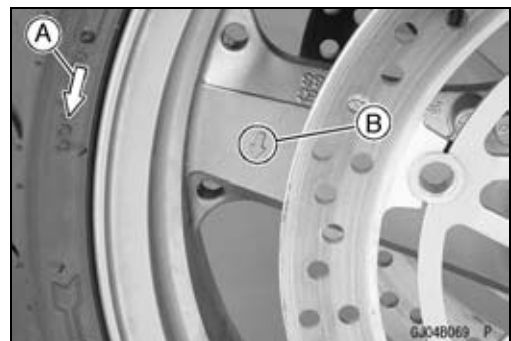

Wheels (Rims)

- Before tightening the clamp bolts on the right fork leg, pump the forks up and down [A] 4 or 5 times to allow the right fork leg to find a neutral position on the front axle.

NOTE

- Do not apply the front brake during this process to stop the motorcycle from rolling forward. Put a block in front of the wheel to stop it from moving.

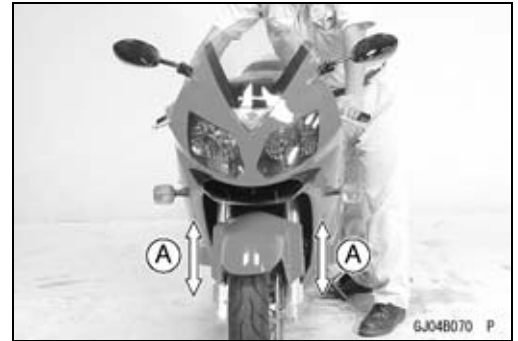

ZX1200-B1/B2

- Tighten the right axle clamp bolts [A] to the specified torque.
- The tightening sequence is left, right and left side bolt to prevent from loosening the bolts.

Torque - Front Axle Clamp Bolts: 20 N·m (2.0 kgf·m, 15 ft·lb)

NOTE

- Tighten the two clamp bolts alternately two times to ensure even tightening torque.

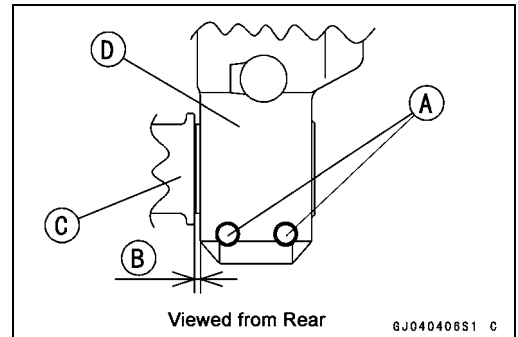

- Check the clearance [B] between the front axle collar [C] and the right fork leg [D]. The clearance between the front axle collar and the right fork leg should be between 0.75 ~ 3.3 mm (0.03 ~ 0.13 in.).

★ If the clearance is out of this range, remove the front wheel again and check the axle, wheel hub and other related parts for damage.

- Next, tighten the left axle clamp bolts to the specified torque.

Torque - Front Axle Clamp Bolts: 20 N·m (2.0 kgf·m, 15 ft·lb)

- Install the front brake caliper (see Brakes chapter).
- Check the front brake.

⚠ WARNING

Do not attempt to ride the motorcycle until a full brake lever is obtained by pumping the brake lever until the pads are against the disc. The brakes will not function on the first application of the lever if this is not done.

10-6 WHEELS/TIRES

Wheels (Rims)

ZX1200-B3

- Tighten the right axle clamp bolts [A] to the specified torque.
- The tightening sequence is left, right and left side bolt to prevent from loosening the bolts.

Torque - Front Axle Clamp Bolts: 20 N·m (2.0 kgf·m, 15 ft·lb)

NOTE

- Tighten the two clamp bolts alternately two times to ensure even tightening torque.
- Check the clearance between the front axle collar [B] and the right fork leg [C].
0 mm [D]
- Next, tighten the left axle clamp bolts to the specified torque.

Torque - Front Axle Clamp Bolts: 20 N·m (2.0 kgf·m, 15 ft·lb)

- Install the front brake caliper (see Brakes chapter).
- Check the front brake.

⚠ WARNING

Do not attempt to ride the motorcycle until a full brake lever is obtained by pumping the brake lever until the pads are against the disc. The brakes will not function on the first application of the lever if this is not done.

Rear Wheel Removal

- Raise the rear wheel off the ground with the stand [A].

- Remove:
 - Cotter Pin [A]
 - Axle Nut [B]
 - Axle [C]

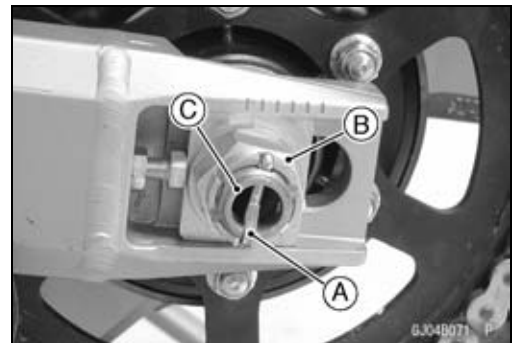
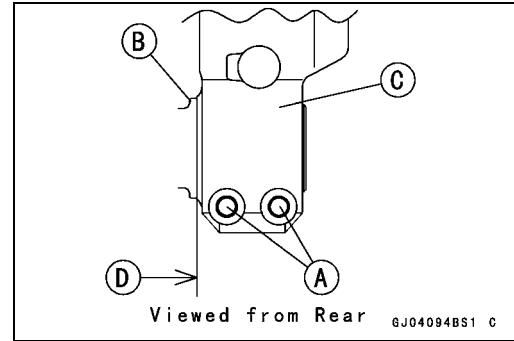

Wheels (Rims)

- Remove the chain [A] from the rear sprocket toward the left.
- Move the rear caliper back and remove the rear caliper from the swingarm.
- Remove the rear wheel.

CAUTION

Do not lay the wheel on the ground with the disc facing down. This can damage or warp the disc. Place blocks under the wheel so that the disc does not touch the ground.

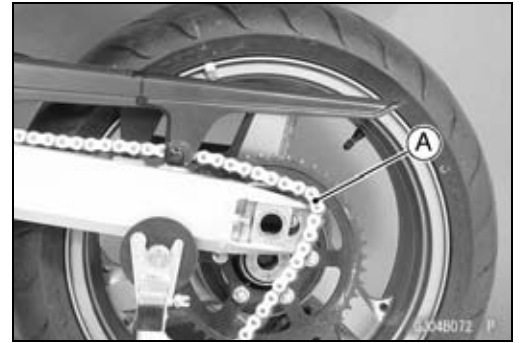

Rear Wheel Installation

- Fit the collers on the both sides of the hub.
Right Side Coller [A]
Left Side Coller [B]

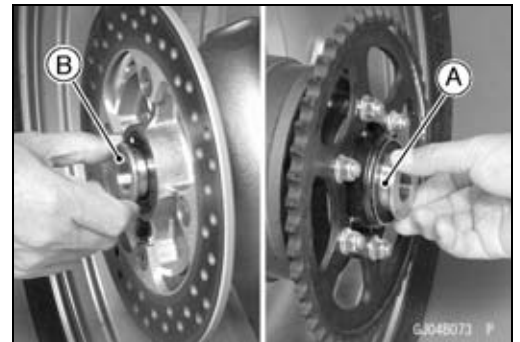

- If the coupling is removed from the rear wheel, apply the grease as shown.

- Coupling [A]
- Wheel Flange [B]
- Apply Grease [C].

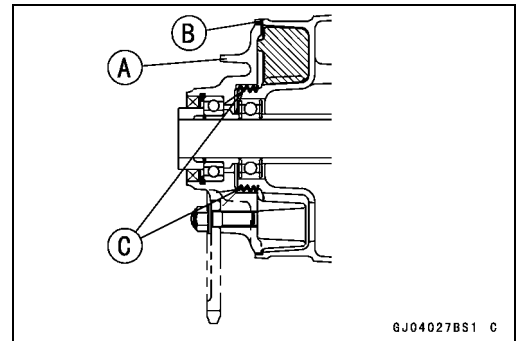

- Engage the drive chain with the rear sprocket.
- Install the caliper bracket [A] onto the swingarm stop [B].
- Install the axle from the right side of the wheel, and tighten the axle nut.

Torque - Rear Axle Nut: 125 N·m (13 kgf·m, 92 ft·lb)

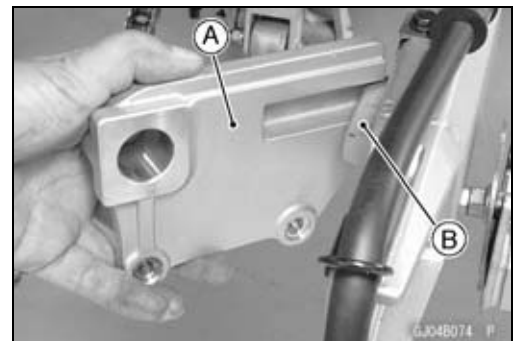

- Insert a new cotter pin [A].

NOTE

- When inserting the cotter pin, if the slots in the nut do not align with the cotter pin hole in the axle, tighten the nut clockwise [B] up to next alignment.
- It should be within 30 degree.
- Loosen once and tighten again when the slot goes past the nearest hole.

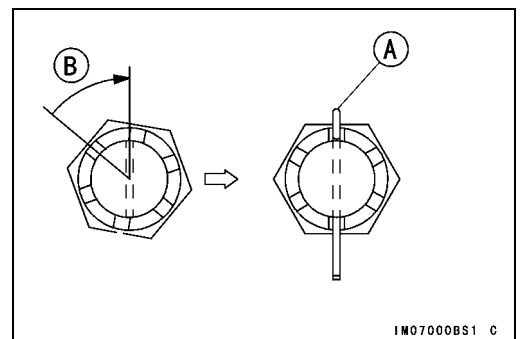

10-8 WHEELS/TIRES

Wheels (Rims)

- Bend the cotter pin [A] over the nut [B].

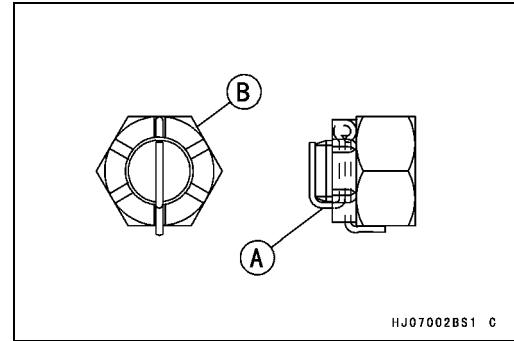

- Adjust the drive chain slack after installation (see Drive Chain Slack Inspection in the Periodic Maintenance chapter).
- Check the rear brake.

⚠ WARNING

Do not attempt to drive the motorcycle until a full brake pedal is obtained by pumping the brake pedal until the pads are against the disc. The brake will not function on the first application of the pedal if this is not done.

Wheel Inspection

- Raise the front/rear wheel off the ground.
Special Tool - Jack: 57001-1238
- Spin the wheel lightly, and check for roughness or binding.
- ★ If roughness or binding is found, replace the hub bearings.
- Inspect the wheel for small cracks, dents, bending, or warp.
- ★ If there is any damage to the wheel, replace the wheel.
- Remove the wheel, and support it without the tire by the axle.
- Measure the rim runout, radial [B] and axial [A], with a dial gauge.
- ★ If rim runout exceeds the service limit, check the hub bearings.
- ★ If the problem is not due to the bearings, replace the wheel.

Rim Runout

Service Limit:

Axial	0.5 mm (0.02 in.)
Radial	0.8 mm (0.03 in.)

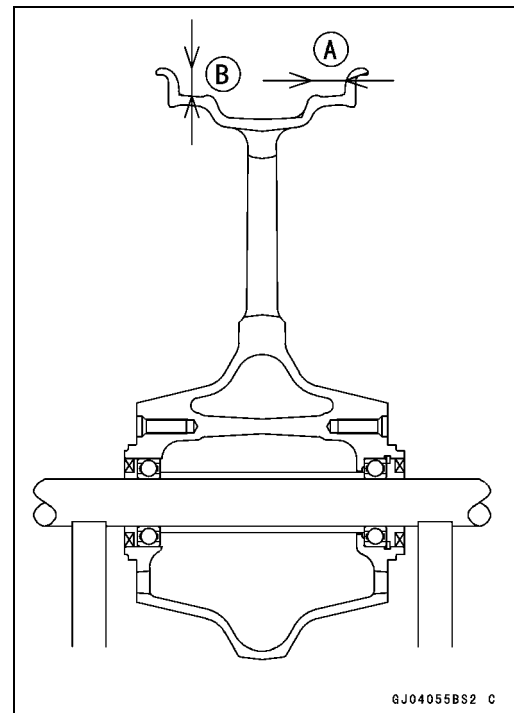

⚠ WARNING

Never attempt to repair a damaged wheel. If there is any damage besides wheel bearings, the wheel must be replaced to insure safe operational condition.

Wheels (Rims)

Axle Inspection

- Visually inspect the front and rear axle for damages.
- ★ If the axle is damaged or bent, replace it.
- Place the axle in V blocks that are 100 mm (3.94 in.) [A] apart, and set a dial gauge [B] on the axle at a point halfway between the blocks. Turn [C] the axle to measure the runout. The difference between the highest and lowest dial readings is the amount of runout.
- ★ If axle runout exceeds the service limit, replace the axle.

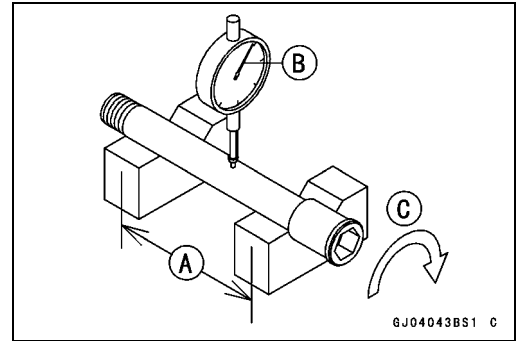

Axle Runout/100 mm (3.94 in.)

Standard: 0.05 mm (0.002 in.) or less

Service Limit: 0.2 mm (0.008 in.)

Balance Inspection

- Remove the wheel.
- Support the wheel so that it can be spun freely.
- Spin the wheel lightly, and mark [A] the wheel at the top when the wheel stops.
- Repeat this procedure several times. If the wheel stops of its own accord in various positions, it is well balanced.
- ★ If the wheel always stops in one position, adjust the wheel balance.

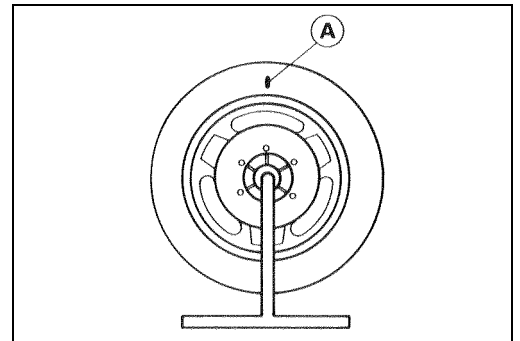

Balance Adjustment

- If the wheel always stops in one position, provisionally attach a balance weight [A] on the rim at the marking using adhesive tape.
- Rotate the wheel 1/4 turn [B], and see whether or not the wheel stops in this position. If it does, the correct balance weight is being used.
- ★ If the wheel rotates and the weight goes up, replace the weight with the next heavier size. If the wheel rotates and the weight goes down, replace the weight with the next lighter size. Repeat these steps until the wheel remains at rest after being rotated 1/4 turn.
- Rotate the wheel another 1/4 turn and then another 1/4 turn to see if the wheel is correctly balanced.
- Repeat the entire procedure as many times as necessary to achieve correct wheel balance.
- Permanently install the balance weight.

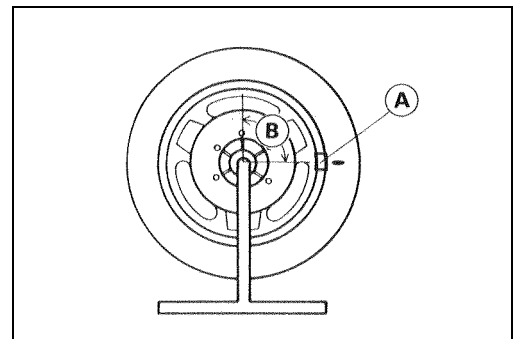

Balance Weight

Part Number	Weight
41075-1014	10 g (0.35 oz)
41075-1015	20 g (0.71 oz)
41075-1016	30 g (1.06 oz)

10-10 WHEELS/TIRES

Wheels (Rims)

Balance Weight Removal

(a) When the tire is not on the rim.

- Push [A] the blade portion toward the outside with a regular tip screw driver, and slip the weight off the rim flange.
- Discard the used balance weight.

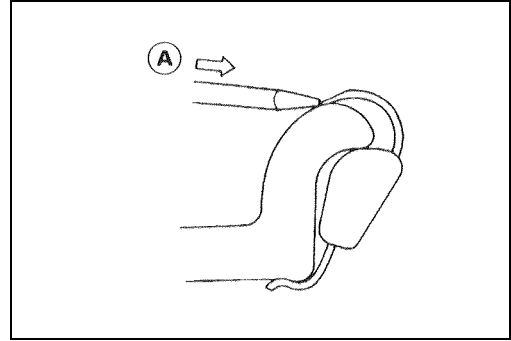

(b) When the tire is on the rim.

- Pry [A] the balance weight off the rim flange using a regular tip screw driver as shown in the figure.
- Insert a tip of the screw driver between the tire bead [B] and weight blade [C] until the end of the tip reaches the end of the weight blade.
- Push the driver grip toward the tire so that the balance weight slips off the rim flange.
- Discard the used balance weight.

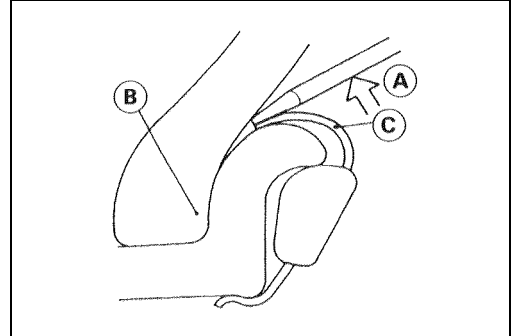

Balance Weight Installation

- Check if the weight portion has any play on the blade-and-clip plate.
- ★ If it does, discard it.

⚠ WARNING

If the balance weight has any play on the rim flange, the blade and/or clip have been stretched. Replace the loose balance weight.

Do not reuse used balance weight.

Unbalanced wheels can create an unsafe riding condition.

- Lubricate the balance weight blade, tire bead, and rim flange with a soap and water solution or rubber lubricant. This helps the balance weight slip onto the rim flange.

CAUTION

Do not lubricate the tire bead with engine oil or petroleum distillates because they will deteriorate the tire.

- Install the balance weight on the rim.
- Slip the weight on the rim flange by pushing or lightly hammering the weight in the direction shown in the figure.
- Check that the blade and weight seat fully on the rim flange, and that the clip is hooked over the rim ridge and reaches rim flat portion. **Installing Balance Weight**

(a) Press or lightly hammer the weight in

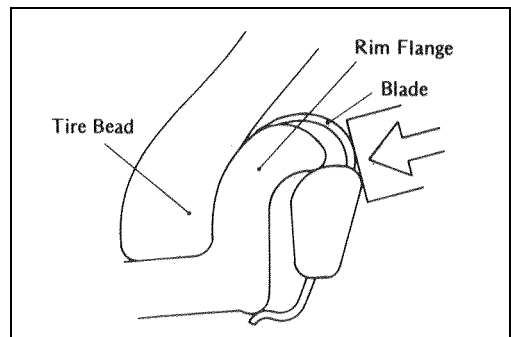

Wheels (Rims)

(b) Installation completed.

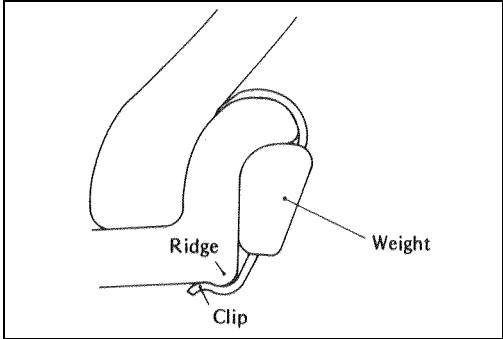

● When required total weight exceeds 20 g (0.71 oz), install balance weight at both sides of rim flange as shown.

Required Total Weight	Weight Selection	
	One Side [A]	Other Side [B]
20 g (0.71 oz)	10 g (0.35 oz)	10 g (0.35 oz)
30 g (1.06 oz)	20 g (0.71 oz)	10 g (0.35 oz)
40 g (1.41 oz)	20 g (0.71 oz)	20 g (0.71 oz)
50 g (1.76 oz)	30 g (1.06 oz)	20 g (0.71 oz)
60 g (2.12 oz)	30 g (1.06 oz)	30 g (1.06 oz)
70 g (2.47 oz)	20 g + 20 g (0.71 oz + 0.71 oz)	30 g (1.06 oz)
80 g (2.82 oz)	20 g + 20 g (0.71 oz + 0.71 oz)	20 g + 20 g (0.71 oz + 0.71 oz)
90 g (3.17 oz)	20 g + 30 g (0.71 oz + 1.06 oz)	20 g + 20 g (0.71 oz + 0.71 oz)

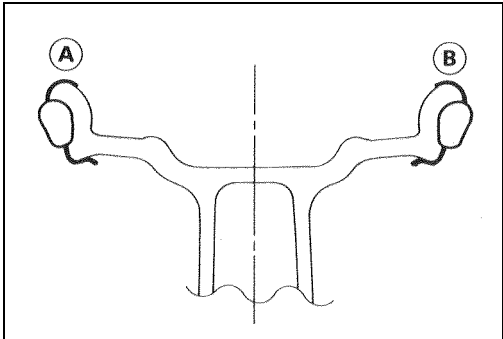

10-12 WHEELS/TIRES

Tires

Air Pressure Inspection/Adjustment

- Measure the tire air pressure with an air pressure gauge [A] when the tires are cold (that is, when the motorcycle has not been ridden more than a mile during the past 3 hours).

★ Adjust the tire air pressure according to the specifications if necessary.

Air Pressure (when cold)

Front:

Up to 182 kg (401 lb) 290 kPa (2.90 kgf/cm², 42 psi)

Rear:

Up to 182 kg (401 lb) 290 kPa (2.90 kgf/cm², 42 psi)

- Install the air valve cap certainly after air pressure inspection.

Torque - Air Valve Cap: 0.15 N·m (0.015 kgf·m, 1.3 in·lb)

Tire Inspection

- Refer to the Tire Inspection in the Periodic Maintenance chapter.

Tire Removal

- Remove:
 - Wheel (see Front Wheel Removal, Rear Wheel Removal)
 - Disc(s) (see Brakes chapter)
 - Valve Core (let out the air)
- To maintain wheel balance, mark the valve stem position on the tire with chalk so that the tire can be reinstalled in the same position.
 - Chalk Mark or Yellow Mark [A]
 - Air Valve [B]
 - Align [C]
- Lubricate the tire beads and rim flanges on both sides with soap and water solution or rubber lubricant. This helps the tire beads slip off the rim flanges.

CAUTION

Never lubricate with engine oil or petroleum distillates because they will deteriorate the tire.

- Remove the tire from the rim using a commercially available tire changer.

NOTE

○ *The tires cannot be removed with hand tools because they fit the rims too tightly.*

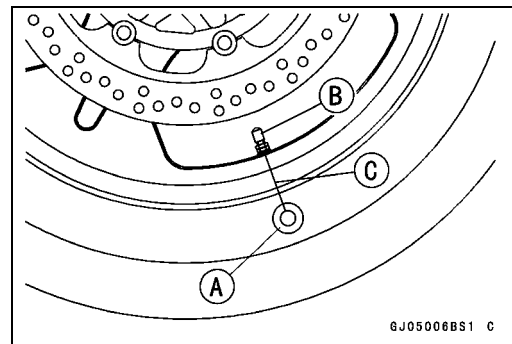
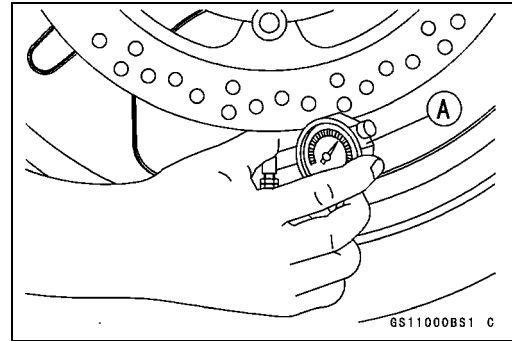

Tires

Tire Installation

⚠ WARNING

Use the same manufacturer's tires on both front and rear wheels.

- Inspect the rim and tire, and replace them if necessary.
- Clean the sealing surfaces of the rim and tire, and smooth the sealing surfaces of the rim with a fine emery cloth if necessary.
- Remove the air valve and discard it.

CAUTION

Replace the air valve whenever the tire is replaced. Do not reuse the air valve.

- Install a new air valve in the rim.
- Remove the valve cap, lubricate the stem seal with soap and water solution or rubber lubricant, and pull the valve stem [A] through the rim from the inside out until it snaps into place.

CAUTION

Do not use engine oil or petroleum distillates to lubricate the stem because they will deteriorate the rubber.

○ The air valve is shown in the figure.

- Valve Cap [A]
- Valve Core [B]
- Valve Seal [C]
- Valve Stem [D]
- Valve Seat [E]
- Valve Opened [F]

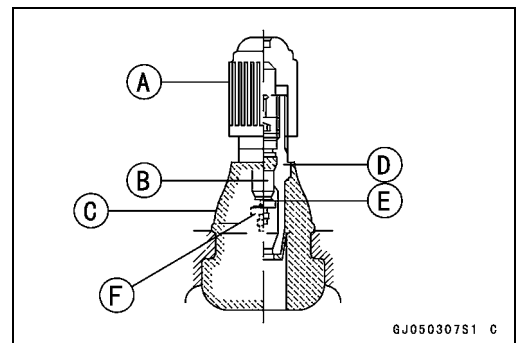
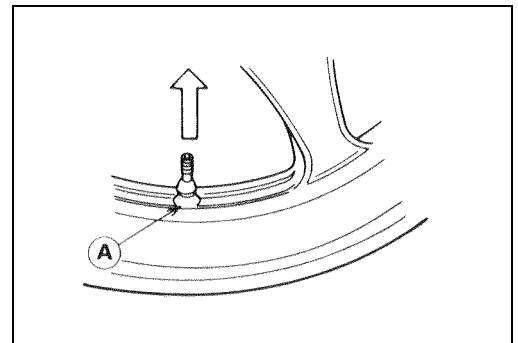

- Apply soap and water solution, or rubber lubricant to the rim flange and tire beads.

○ Check the tire rotation mark on the front and rear tires and install them on the rim accordingly.

NOTE

○ The direction of the tire rotation [A] is shown by an arrow [B] on the tire sidewall.

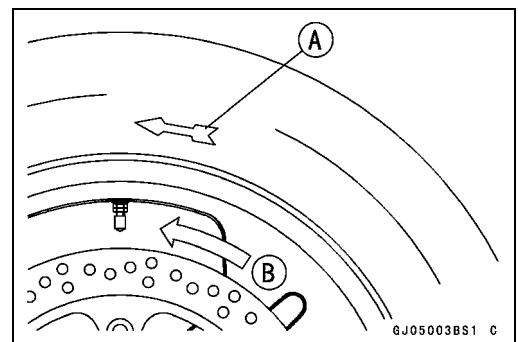

10-14 WHEELS/TIRES

Tires

- Position the tire on the rim so that the valve [A] is at the tire balance mark [B] (the chalk mark made during removal, or the yellow paint mark on a new tire).
- Install the tire on the rim using a suitable commercially available tire changer.
- Lubricate the tire beads and rim flanges with soap and water solution or rubber lubricant to help seat the tire beads in the sealing surfaces of the rim while inflating the tire.
- Center the rim in the tire beads, and inflate the tire with compressed air until the tire beads seat in the sealing surfaces.

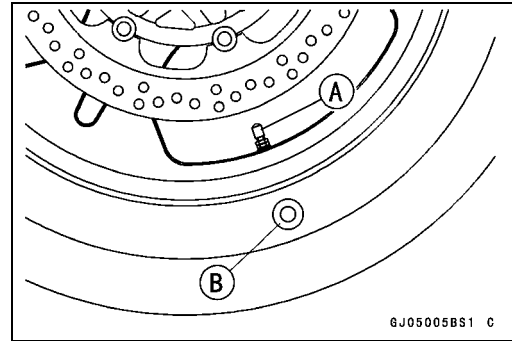

⚠ WARNING

Be sure to install the valve core whenever inflating the tire, and do not inflate the tire to more than 400 kPa (4.0 kgf/cm², 57 psi). Overinflation can explode the tire with possibility of injury and loss of life.

- Check to see that the rim lines [A] on both sides of the tire sidewalls are parallel with the rim flanges.
 - ★ If the rim flanges and tire sidewall rim lines are not parallel, remove the valve core.
 - Lubricate the rim flanges and tire beads.
 - Install the valve core and inflate the tire again
 - After the tire beads seat in the rim flanges, check for air leaks.
 - Inflate the tire slightly above standard inflation.
 - Use soap and water solution or submerge the tire, and check for bubbles that would indicate leakage.
 - Adjust the air pressure to the specified pressure.
 - Install the air valve cap.
 - Install the brake disc(s) so that the disc rotation mark aligns with the tire rotation.
 - Apply a non-permanent locking agent, and tighten the brake disc bolts.
- Torque - Brake Disc Bolts: 27 N·m (2.8 kgf·m, 20 ft·lb)**
- Adjust the wheel balance.

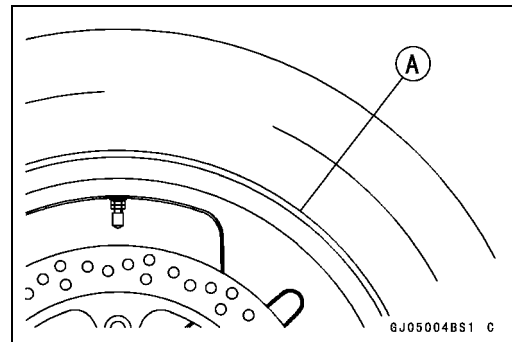

⚠ WARNING

Check and balance the wheel when a tire is replaced with a new one.
New tires are slippery and may cause loss of control and injury.
A break-in period of 160 km (100 miles) is necessary to establish normal tire traction. During break-in, avoid sudden and maximum braking and acceleration, and hard cornering.

Tires

Repair

Currently two types of repair for tubeless tires have come into wide use. One type is called a temporary (external) repair which can be carried out without removing the tire from the rim, and the other type is called permanent (internal) repair which requires tire removal. It is generally understood that higher running durability is obtained by permanent (internal) repairs than by temporary (external) ones. Also, permanent (internal) repairs have the advantage of permitting a thorough examination for secondary damage not visible from external inspection of the tire. For these reasons, Kawasaki does not recommend temporary (external) repair. Only appropriate permanent (internal) repairs are recommended. Repair methods may vary slightly from make to make. Follow the repair methods indicated by the manufacturer of the repair tools and materials so that safe results can be obtained.

10-16 WHEELS/TIRES

Hub Bearings

Hub Bearing Removal

- Remove the wheel, and take out the following.
 - Collars
 - Coupling (Out of rear hub)
 - Grease Seals
 - Circlip

Special Tool - Inside Circlip Pliers: 57001-143

- Take the bearings [A] out of the hub.

CAUTION

Do not lay the wheel on the ground with the disc facing down. This can damage or warp the disc. Please blocks under the wheel so that the disc does not touch the ground.

Special Tools - Bearing Remover Head, $\phi 25 \times \phi 28$: 57001-1346 [C]

Bearing Remover Shaft, $\phi 13$: 57001-1377 [B]

Hub Bearing Installation

- Before installing the wheel bearings, blow any dirt or foreign particles out of the hub with compressed air to prevent contamination of the bearings.
- Replace the bearings with new ones.
- Press in each right the bearing [A] until they are bottomed.

Special Tool - Bearing Driver Set: 57001-1129 [B]

NOTE

○ Install the bearings so that the marked side faces out.

- Replace the circlips with new ones.

Special Tool - Inside Circlip Pliers: 57001-143

- Replace the grease seals with new ones.
- Press in the grease seals [A] so that the seal surface flush [B] with the end of the hole.
- Apply high temperature grease to the grease seal lips.

Special Tool - Bearing Driver Set: 57001-1129 [C]

Hub Bearing Inspection

NOTE

○ It is not necessary to remove any bearings for inspection. If any bearings are removed, they will need to be replaced with new ones.

- Spin [A] it by hand to check its condition.
- ★ If it is noisy, does not spin smoothly, or has any rough spots, it must be replaced.
- Examine the bearing seal [B] for tears or leakage.
- ★ If the seal is torn or is leaking, replace the bearing.

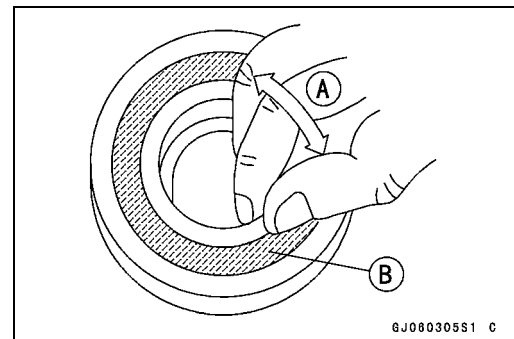
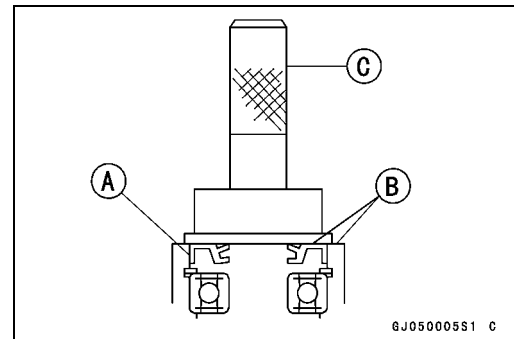
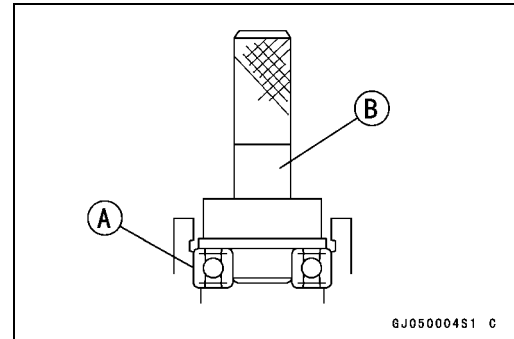
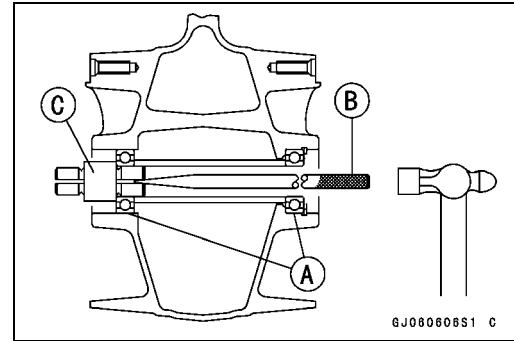

Final Drive

Table of Contents

Exploded View	11-2
Specifications	11-3
Drive Chain	11-4
Slack Inspection	11-4
Slack Adjustment	11-4
Wheel Alignment Inspection Adjustment	11-4
Drive Chain Wear Inspection	11-4
Lubrication	11-4
Drive Chain Removal	11-4
Drive Chain Installation	11-4
Sprocket, Coupling	11-5
Engine Sprocket Removal	11-5
Engine Sprocket Installation	11-5
Rear Sprocket Removal	11-6
Rear Sprocket Installation	11-6
Sprocket Wear Inspection	11-6
Rear Sprocket Warp Inspection	11-7
Coupling Bearing Removal	11-7
Coupling Bearing Installation	11-7
Coupling Installation	11-8
Coupling Bearing Inspection and Lubrication	11-8
Damper Inspection	11-8

11-2 FINAL DRIVE

Exploded View

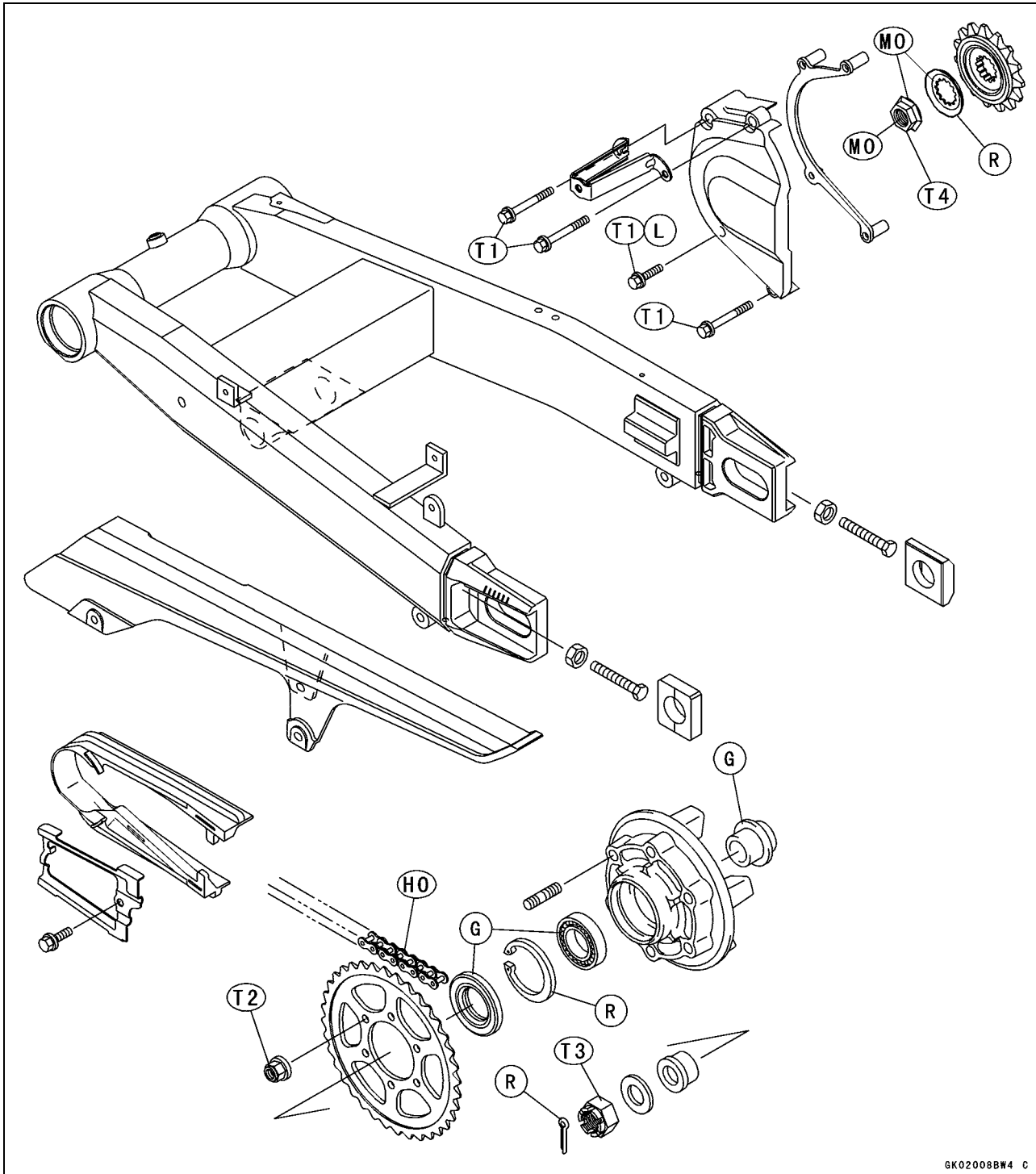

GK02008BW4 C

T1: 12 N·m (1.2 kgf·m, 106 in·lb)

T2: 59 N·m (6.0 kgf·m, 44 ft·lb)

T3: 125 N·m (13 kgf·m, 92 ft·lb)

T4: 127 N·m (13 kgf·m, 94 ft·lb)

G: Apply grease.

HO: Apply heavy oil.

L: Apply a non-permanent locking agent.

MO: Apply molybdenum disulfide oil solution.

R: Replacement Parts

Specifications

Item	Standard	Service Limit
Drive Chain		
Chain Slack	25 ~ 35 mm (0.98 ~ 1.4 in.)	— — —
Rollers Distance	Less than 6 mm (0.236 in.)	6.2 mm (0.244 in.)
20-link Length	317.5 ~ 318.2 mm (12.50 ~ 12.53 in.)	323 mm (12.7 in.)
Standard Chain:		
Make	DAIDO	— — —
Type	DID50ZVM3GC&B, Endless	— — —
Link	116 links	— — —
Sprockets		
Rear Sprocket Warp	0.4 mm (0.02 in.) or less	0.5 mm (0.02 in.)

Special Tools - Inside Circlip Pliers: 57001-143

Bearing Driver Set: 57001-1129

11-4 FINAL DRIVE

Drive Chain

Slack Inspection

- Refer to the Drive Chain Inspection in the Periodic Maintenance chapter.

Slack Adjustment

- Refer to the Drive Chain Inspection in the Periodic Maintenance chapter.

Wheel Alignment Inspection Adjustment

- Refer to the Drive Chain Inspection in the Periodic Maintenance chapter.

Drive Chain Wear Inspection

- Refer to the Drive Chain Wear Inspection in the Periodic Maintenance chapter.

Lubrication

- Refer to the Drive Chain Lubrication in the Periodic Maintenance chapter.

Drive Chain Removal

- Remove:
 - Rear Wheel (see Wheels/Tires chapter)
 - Chain Cover Screws [A]
 - Chain Cover [B]
 - Brake Hose Clamp Screw [C] and Bolts [D]
 - Swingarm (see Suspension chapter)
 - Engine Sprocket Cover (see this chapter)
- Disengage the drive chain [A] from the engine sprocket [B], and take it off the chassis.

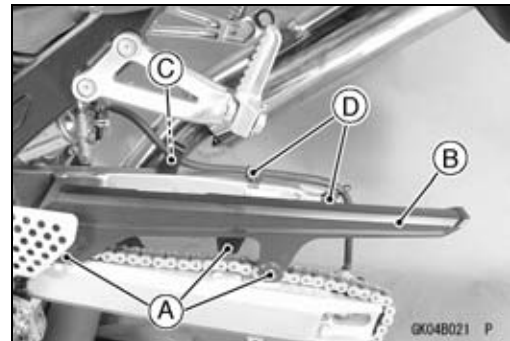

Drive Chain Installation

- Engage the drive chain to the engine sprocket.
- Install:
 - Swingarm (see Suspension chapter)
 - Rear Wheel (see Wheels/Tires chapter)
 - Engine Sprocket Cover (see Engine Sprocket Installation)
 - Chain Cover
- Adjust the chain slack after installing the chain (see Drive Chain Inspection in the Periodic Maintenance chapter).

Sprocket, Coupling

Engine Sprocket Removal

- Remove:
 - Engine Sprocket Cover Bolts [A]
 - Engine Sprocket Cover [C]
- Chain guide bolt [B] need not to be removed for engine sprocket cover removal.

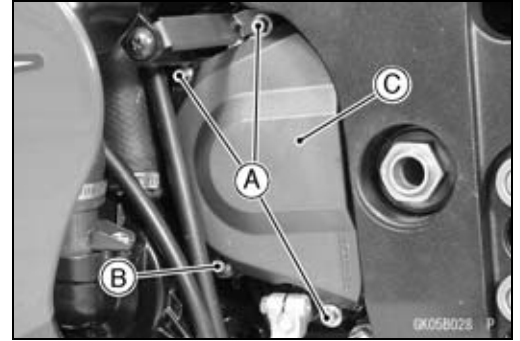

- Flatten out the bended washer [A].
- Remove the engine sprocket nut [B] and washer.

NOTE

- When loosening the engine sprocket nut, hold the rear brake on.

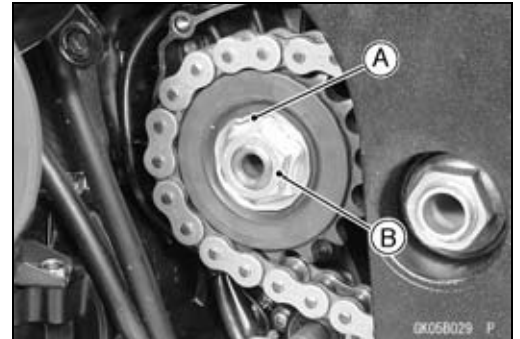

- Raise the rear wheel off the ground with the stand (see Wheels/Tires chapter).
- Loosen the drive chain (see Drive Chain Inspection in the Periodic Maintenance chapter).
- Remove the drive chain from the rear sprocket toward the right.
- Disengage the drive chain [A] from the engine sprocket [B].
- Pull the engine sprocket off the output shaft [C].

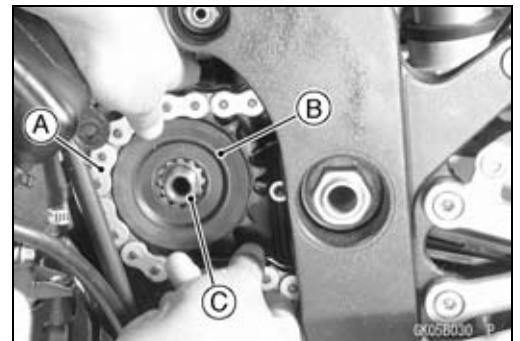

Engine Sprocket Installation

- Replace the sprocket washer and axle cotter pin.
- Install the engine sprocket.
- Apply molybdenum disulfide oil solution to the threads of the output shaft, and to the seating surface of the engine sprocket nut and washer.
- After torquing the engine sprocket nut, bend the one side of the washer over the nut.

NOTE

- Tighten the nut while applying the rear brake.

Torque - Engine Sprocket Nut: 127 N·m (13 kgf·m, 94 ft·lb)

11-6 FINAL DRIVE

Sprocket, Coupling

- Install the engine sprocket cover.
- Apply a non-permanent locking agent to the chain guide mounting bolt [A] if it is removed.

Torque - Engine Sprocket Cover Bolts: 12 N·m (1.2 kgf·m, 106 in·lb)

- Adjust the drive chain slack after installing the sprocket (see Drive Chain Inspection in the Periodic Maintenance chapter).

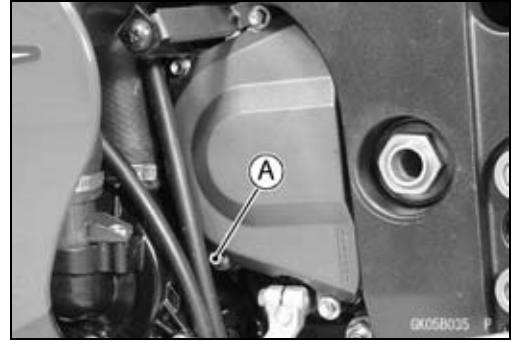

Rear Sprocket Removal

- Remove the rear wheel (see Wheels/Tires chapter).

CAUTION

Do not lay the wheel on the ground with the disc facing down. This can damage or warp the disc. Place blocks under the wheel so that the disc does not touch the ground.

- Remove the rear sprocket nuts [A].
- Remove the rear sprocket [B].

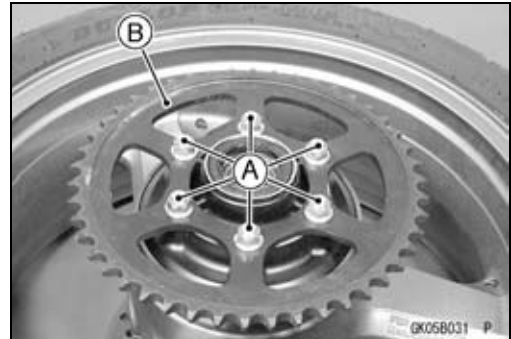

Rear Sprocket Installation

- Install the sprocket facing the tooth number marking [A] outward.
- Tighten the rear sprocket nuts.

Torque - Rear Sprocket Nuts: 59 N·m (6.0 kgf·m, 44 ft·lb)

- Install the rear wheel (see Wheels/Tires chapter).



Sprocket Wear Inspection

- Visually inspect the engine and rear sprocket teeth for wear and damage.
- ★ If the teeth are worn as illustrated, replace the sprocket, and inspect the drive chain wear (see Drive Chain Wear Inspection).

Worn Tooth (Engine Sprocket) [A]

Worn Tooth (Rear Sprocket) [B]

Direction of Rotation [C]

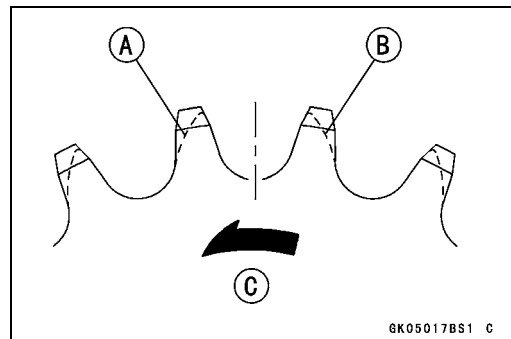

NOTE

- If a sprocket requires replacement, the chain is probably worn also. When replacing a sprocket, inspect the chain

Sprocket, Coupling

Rear Sprocket Warp Inspection

- Raise the rear wheel off the ground (see Wheels/Tires chapter) so that it will turn freely.
- Set a dial gauge [A] against the rear sprocket [B] near the teeth as shown, and rotate [C] the rear wheel to measure the sprocket runout (warp). The difference between the highest and lowest dial gauge readings is the amount of runout (warp).
- ★ If the runout exceeds the service limit, replace the rear sprocket.

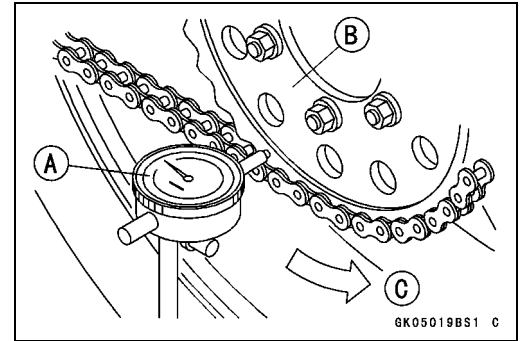

Rear Sprocket Warp

- Standard:** 0.4 mm (0.02 in.) or less
- Service Limit:** 0.5 mm (0.02 in.)

Coupling Bearing Removal

- Remove the rear wheel (see Wheels/Tires chapter).
- Remove:
 - Coupling
 - Grease Seal
 - Circlip [A]
- Special Tool - Inside Circlip Pliers: 57001-143 [B]**

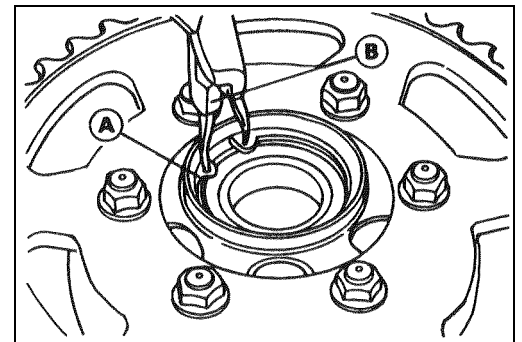

- Remove the bearing [A] by tapping from the wheel side.
- Special Tool - Bearing Driver Set: 57001-1129 [B]**

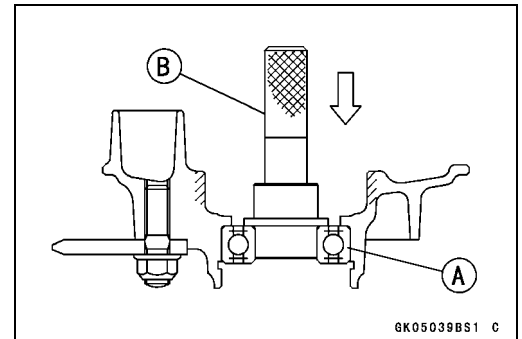

Coupling Bearing Installation

- Replace the bearing with a new one.
- Press in the bearing [A] until it is bottomed.
- Special Tool - Bearing Driver Set: 57001-1129 [B]**
- Pack the bearing with high temperature grease.
- Replace the circlip with a new one.
- Special Tool - Inside Circlip Pliers: 57001-143**

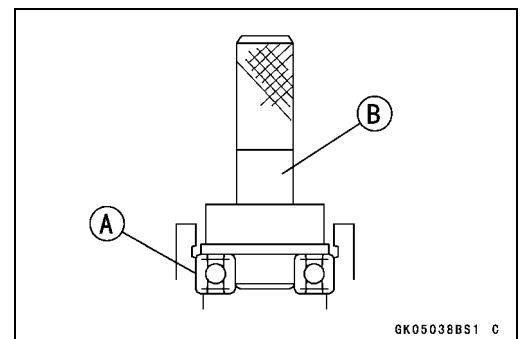

11-8 FINAL DRIVE

Sprocket, Coupling

- Replace the grease seal with a new one.
- Press in the grease seal so that the seal surface is flush with the end of the hole.
- Apply high temperature grease to the grease seal lips.

Special Tool - Bearing Driver Set: 57001-1129 [A]

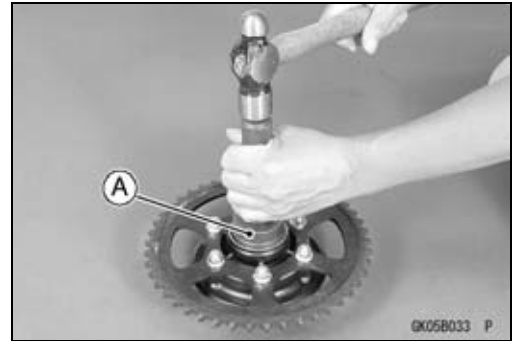

Coupling Installation

- Grease the following and install the coupling.
 - Coupling Grease Seal [A]
 - Coupling Internal Surface [B]
 - Ball Bearing [C]

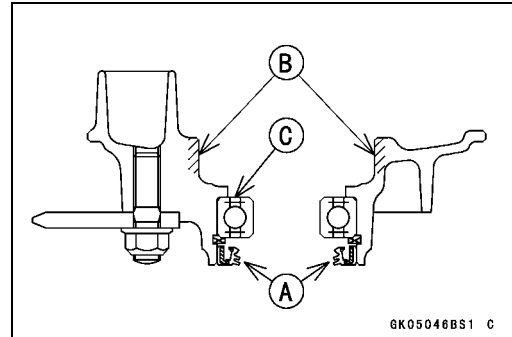

Coupling Bearing Inspection and Lubrication

NOTE

- *It is not necessary to remove the coupling bearing for inspection and lubrication. If the bearing is removed, it will need to be replaced with a new one.*
- Wash the bearing with a high flash-point solvent, dry it (do not spin it while it is dry), and oil it. Spin it by hand to check its condition.
- ★ If it is noisy, does not spin smoothly, or has any rough spots, it must be replaced.
- Pack the bearing with good quality bearing grease. Turn the bearing around by hand a few times to make sure the grease is distributed uniformly inside the bearing.

Damper Inspection

- Remove the rear wheel coupling, and inspect the rubber dampers [A].
- Replace the damper if it appears damaged or deteriorated.



Brakes

Table of Contents

Exploded View	12-2	Brake Pad Lining Wear	12-20
Specifications	12-8	Master Cylinder	12-21
Brake Pedal	12-9	Front Master Cylinder Removal ...	12-21
Brake Lever Position Adjustment.	12-9	Front Master Cylinder Installation	12-21
Brake Pedal Position Adjustment.	12-9	Rear Master Cylinder Removal....	12-22
Brake Lever, Brake Pedal.....	12-10	Rear Master Cylinder Installation.	12-22
Brake Pedal Removal	12-10	Front Master Cylinder	
Brake Pedal Installation	12-10	Disassembly.....	12-22
Calipers	12-11	Rear Master Cylinder	
Front Caliper Removal	12-11	Disassembly.....	12-23
Rear Caliper Removal.....	12-11	Master Cylinder Assembly	12-23
Caliper Installation	12-11	Master Cylinder Inspection (Visual	
Front Caliper Disassembly.....	12-12	Inspection).....	12-24
Front Caliper Assembly.....	12-13	Brake Discs	12-25
Rear Caliper Disassembly	12-14	Brake Disc Removal	12-25
Rear Caliper Assembly	12-15	Brake Disc Installation	12-25
Caliper Fluid Seal Damage	12-16	Brake Disc Wear	12-25
Caliper Dust Seal Damage	12-17	Brake Disc Warp	12-25
Caliper Piston and Cylinder		Brake Fluid	12-26
Damage.....	12-17	Brake Fluid Level Inspection.....	12-26
Brake Pads	12-18	Brake Fluid Change	12-26
Front Brake Pad Removal.....	12-18	Bleeding the Brake Line.....	12-26
Front Brake Pad Installation.....	12-19	Brake Hoses	12-29
Rear Brake Pad Removal	12-19	Brake Hose Removal/Installation.	12-29
Rear Brake Pad Installation	12-20	Brake Hose Inspection.....	12-29

12-2 BRAKES

Exploded View

ZX1200-B1/B2

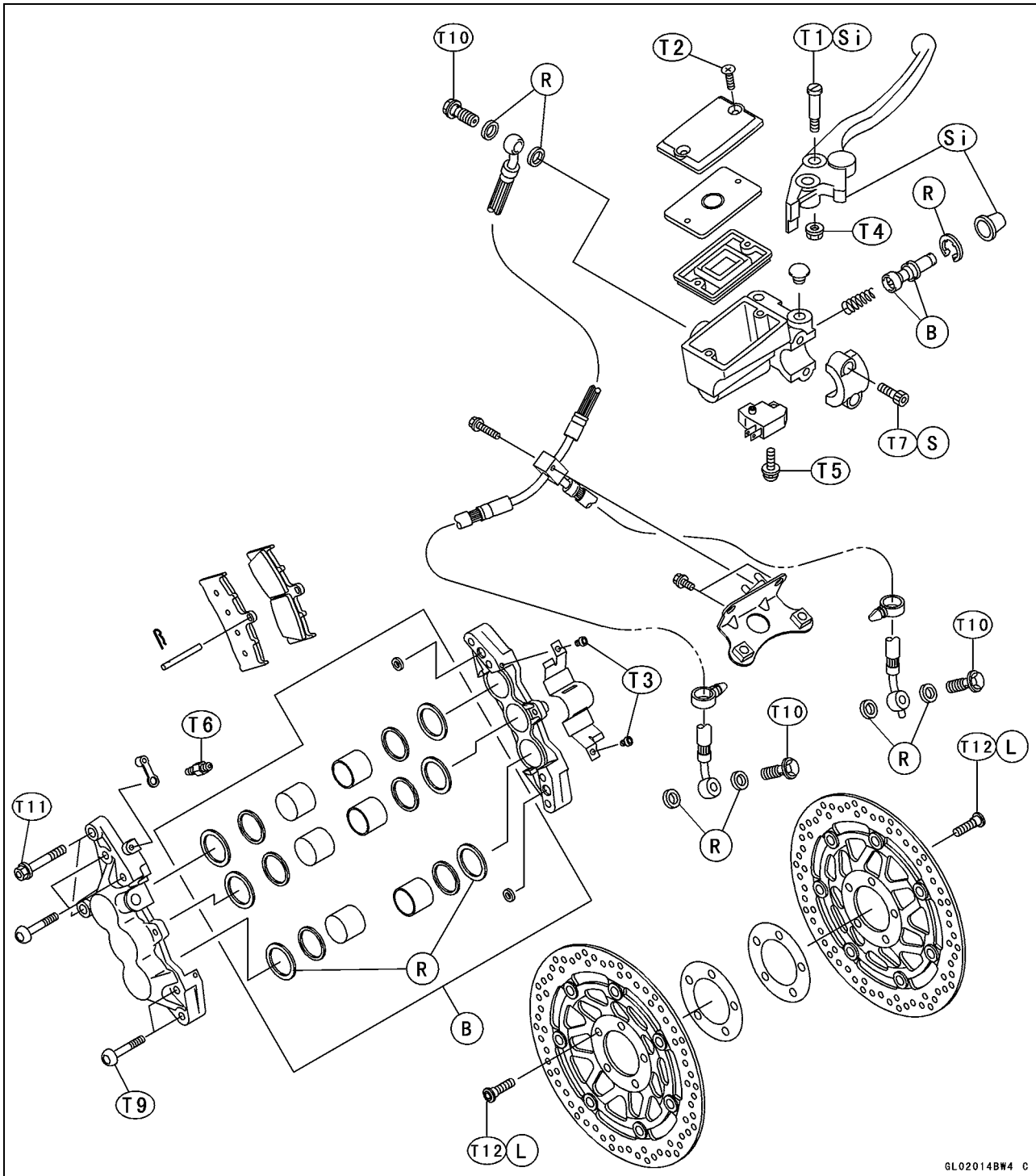

GL02014BW4 C

- T1: 1.0 N·m (0.10 kgf·m, 9 in·lb)
- T2: 1.5 N·m (0.15 kgf·m, 13 in·lb)
- T3: 3.0 N·m (0.30 kgf·m, 27 in·lb)
- T4: 6.0 N·m (0.60 kgf·m, 52 in·lb)
- T5: 1.2 N·m (0.12 kgf·m, 11 in·lb)
- T6: 7.8 N·m (0.80 kgf·m, 69 in·lb)
- T7: 8.8 N·m (0.90 kgf·m, 78 in·lb)
- T8: 18 N·m (1.8 kgf·m, 13 ft·lb)
- T9: 21 N·m (2.1 kgf·m, 15 ft·lb)
- T10: 25 N·m (2.5 kgf·m, 18 ft·lb)

- T11: 34 N·m (3.5 kgf·m, 25 ft·lb)
- T12: 27 N·m (2.8 kgf·m, 20 ft·lb)
- T13: 30 N·m (3.0 kgf·m, 22 ft·lb)
- B: Apply brake fluid.
- G: Apply grease.
- L: Apply a non-permanent locking agent.
- R: Replacement Parts
- S: Follow the specific tightening sequence.
- Si: Apply silicone grease (ex. PBC grease).

Exploded View

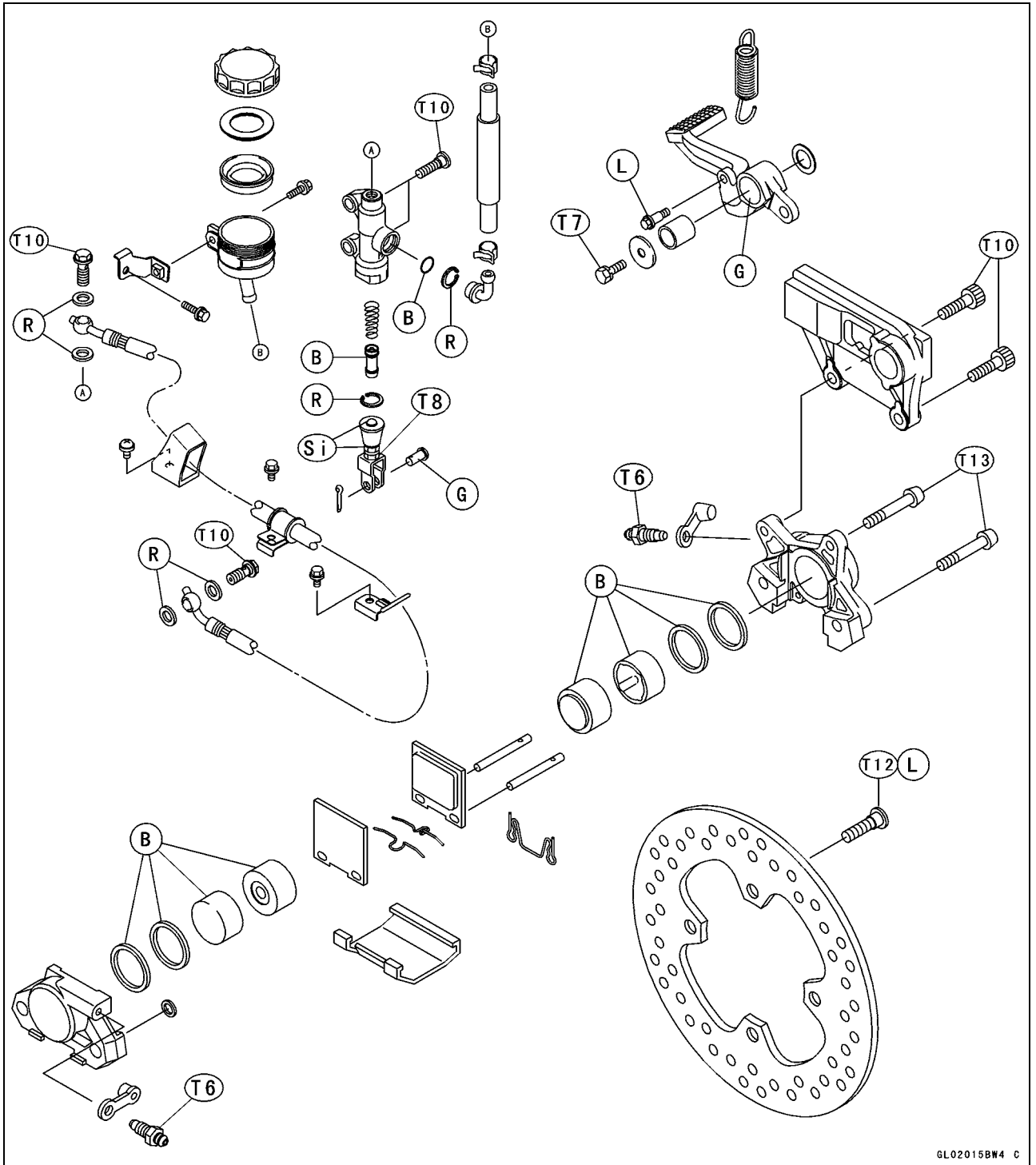

12-4 BRAKES

Exploded View

ZX1200-B3

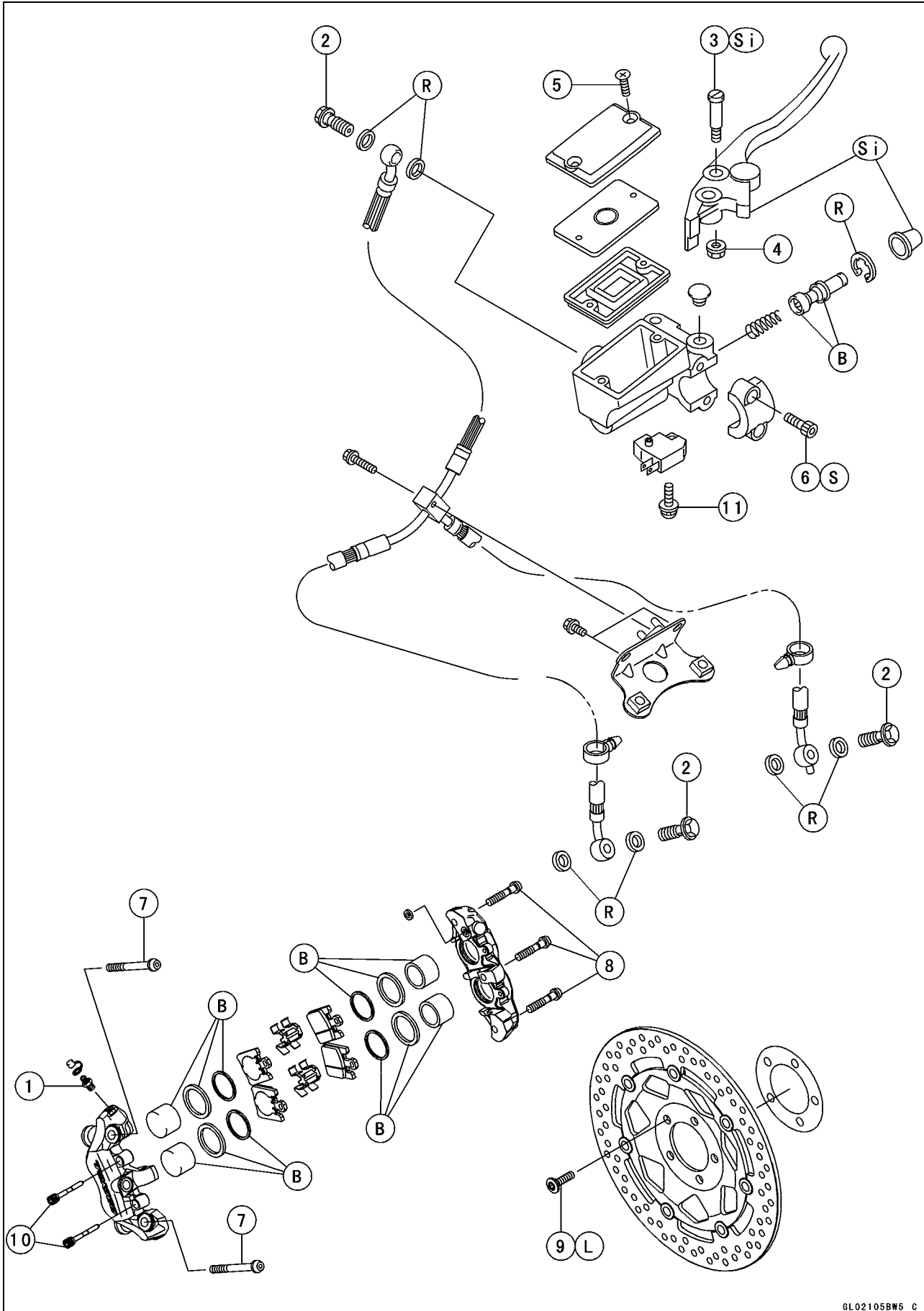

Exploded View

No.	Fastener	Torque			Remarks
		N·m	kgf·m	ft·lb	
1	Bleed Valve	7.8	0.80	69 in·lb	
2	Brake Hose Banjo Bolts	25	2.5	18	
3	Brake Lever Pivot Bolt	1.2	0.12	11 in·lb	Si
4	Brake Lever Pivot Bolt Locknut	6.0	0.60	52 in·lb	
5	Front Reservoir Cap Screws	1.5	0.15	13 in·lb	
6	Front Master Cylinder Clamp Bolts	8.8	0.90	78 in·lb	S
7	Front Caliper Mounting Bolts	34	3.5	25	
8	Front Caliper Assembly Bolts	21	2.1	15	
9	Brake Disc Mounting Bolts	27	2.8	20	L
10	Front Brake Pad Pins	15	1.5	11	
11	Front Brake Light Switch Screws	1.2	0.12	11 in·lb	

B: Apply brake fluid.

L: Apply a non-permanent locking agent.

R: Replacement Parts

S: Follow the specific tightening sequence.

Si: Apply silicone grease (ex. PBC grease).

12-6 BRAKES

Exploded View

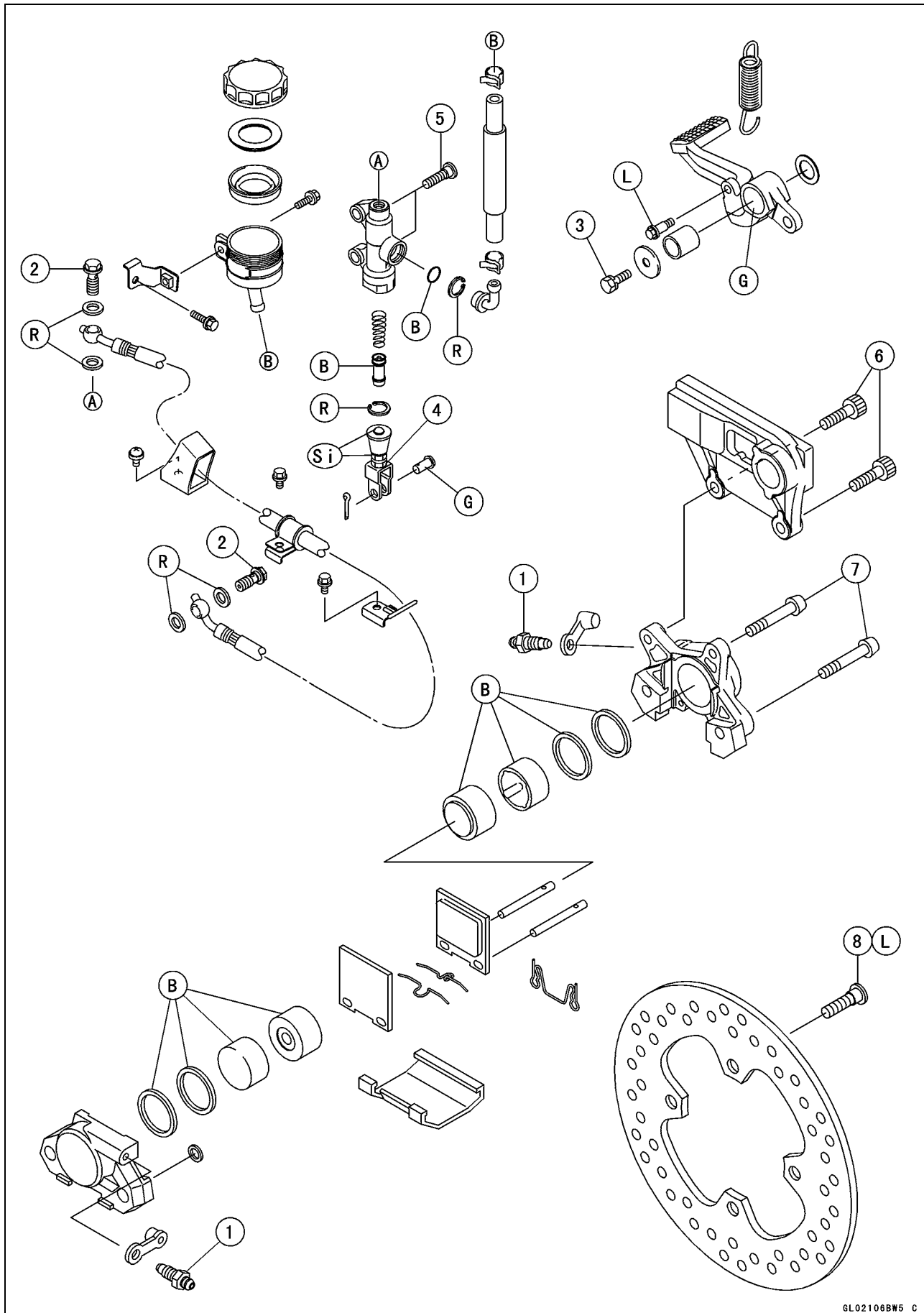

Exploded View

No.	Fastener	Torque			Remarks
		N·m	kgf·m	ft·lb	
1	Bleed Valve	7.8	0.80	69 in·lb	
2	Brake Hose Banjo Bolts	25	2.5	18	
3	Brake Pedal Mounting Bolt	8.8	0.90	78 in·lb	
4	Rear Master Cylinder Push Rod Locknut	18	1.8	13	
5	Front Master Cylinder Mounting Bolts	25	2.5	18	
6	Rear Caliper Mounting Bolts	25	2.5	18	
7	Rear Caliper Assembly Bolts	30	3.0	22	
8	Brake Disc Mounting Bolts	27	2.8	20	L

B: Apply brake fluid.

G: Apply grease.

L: Apply a non-permanent locking agent.

R: Replacement Parts

Si: Apply silicone grease (ex. PBC grease).

12-8 BRAKES

Specifications

Item	Standard	Service Limit
Brake Lever, Brake Pedal		
Brake Lever Position	5-way adjustable (to suit rider)	---
Brake Lever Free Play	Non-adjustable	---
Pedal Free Play	Non-adjustable	---
Pedal Position	About 43 mm (1.7 in.) below footpeg top	---
Brake Fluid		
Grade	DOT4	---
Brake Pads		
Lining Thickness:		
Front	4 mm (0.12 in.)	1 mm (0.04 in.)
Rear	4 mm (0.12 in.)	1 mm (0.04 in.)
Brake Discs		
Thickness:		
ZX1200-B1/B2		
Front	4.8 ~ 5.1 mm (0.19 ~ 0.20 in.)	4.5 mm (0.18 in.)
Rear	5.8 ~ 6.0 mm (0.23 ~ 0.24 in.)	5.0 mm (0.20 in.)
ZX1200-B3		
Front	5.8 ~ 6.2 mm (0.23 ~ 0.24 in.)	5.5 mm (0.22 in.)
Rear	5.9 ~ 6.1 mm (0.23 ~ 0.24 in.)	5.0 mm (0.20 in.)
Runout	0.15 mm (0.0059 in.) or less	0.3 mm (0.01 in.)

Special Tools - Inside Circlip Pliers: 57001-143

Jack: 57001-1238

Brake Pedal

Brake Lever Position Adjustment

The brake lever is adjustable to five positions to suit the rider.

- Push the lever forward and turn the adjuster [A] to align the number with the arrow mark [B].
- The distance from the grip to the lever is maximum at Number 1 and minimum at Number 5.

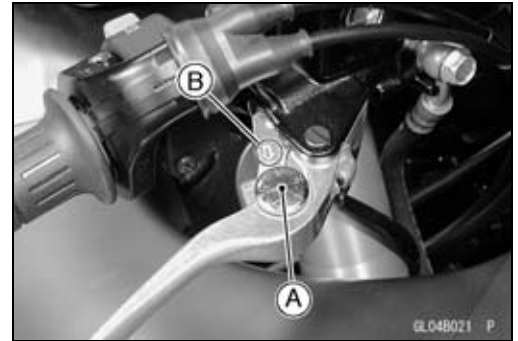

Brake Pedal Position Adjustment

- Check that the brake pedal [A] is in the correct position. Footpeg [B]

Pedal Position [C]

Standard: About 43 mm (1.7 in.) below top of footpeg

- ★ If it is incorrect, adjust the brake pedal position.

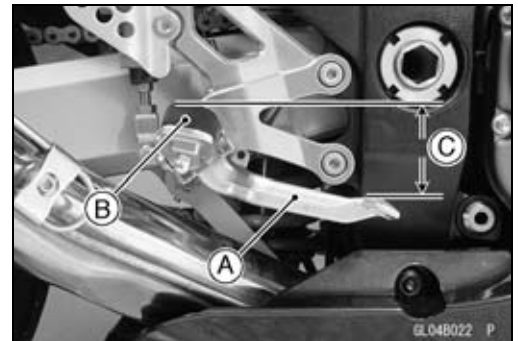

NOTE

○ Usually it is not necessary to adjust the pedal position, but always adjust it when the master cylinder is disassembled or pedal position is incorrect.

- Unscrew the bolts [A] and remove the guard bracket [B].
- Reinstall the bolts with master cylinder.

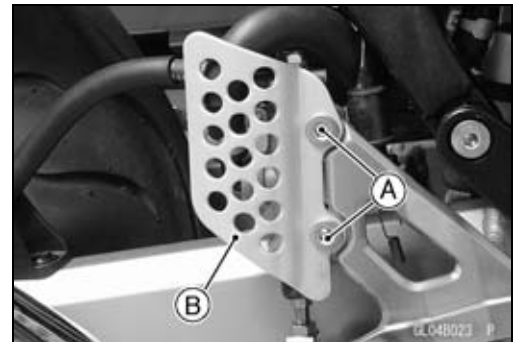

- Measure the length indicated in the figure.

Length [A]

Standard: 67 ±1 mm (2.64 ±0.04 in.)

- ★ If it is specified length, the brake pedal may be deformed or incorrectly installed.
- ★ If it is not within the specified length, adjust the push rod in the master cylinder as following.

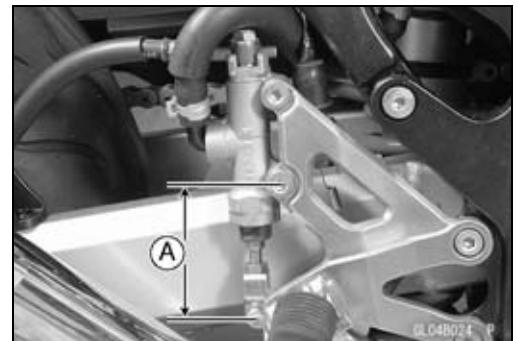

- Loosen the push rod locknut [A].
- Turn the hex head [B] of the push rod [C] to obtain the specified length [D].
- Tighten the locknut.

Torque - Rear Master Cylinder Push Rod Locknut: 18 N·m (1.8 kgf·m, 13 ft·lb)

- Install the master cylinder guard with master cylinder assembly.

Torque - Rear Master Cylinder Mounting Bolts: 25 N·m (2.5 kgf·m, 18 ft·lb)

- Check the brake light switch operation (see Electrical System chapter).

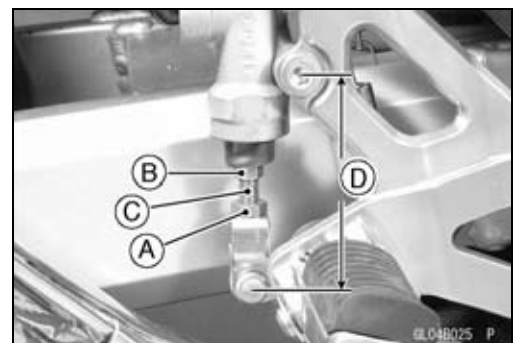

12-10 BRAKES

Brake Lever, Brake Pedal

Brake Pedal Removal

- Remove:
 - Right Front Footpeg Holder Bolts [A]
 - Rear Master Cylinder Mounting Bolts [B]

- Remove:
 - Cotter Pin [A]
 - Joint Pin [B] (see Rear Master Cylinder Removal)
- Remove the rear brake light switch spring [C].
- Remove the return spring [D].
- Remove the mounting bolt [E] and take out the brake pedal [F].

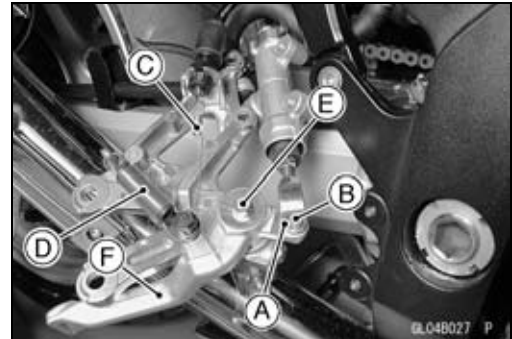
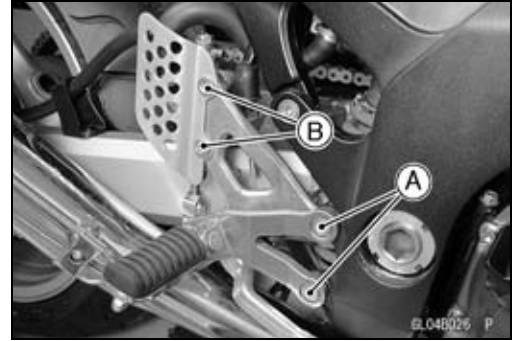

Brake Pedal Installation

- Apply high-temperature grease to the pivot shaft [A] and install the washer [B] and pedal [C].
Torque - Brake Pedal Mounting Bolt: 8.8 N·m (0.90 kgf·m, 78 in·lb)
- Hook the return spring and brake light switch spring.
- Apply high-temperature grease to the joint pin, insert it to the brake pedal and master cylinder.
- Insert the cotter pin and spread its ends.
- Replace the cotter pin with a new one.
- Install the footpeg holder assembly to the frame.
Torque - Right Front Footpeg Holder Bolts: 25 N·m (2.5 kgf·m, 18 ft·lb)
- Install the rear master cylinder (see Rear Master Cylinder Installation).
Torque - Rear Master Cylinder Mounting Bolts: 25 N·m (2.5 kgf·m, 18 ft·lb)
- Check the brake pedal position (see Brake Pedal Position Inspection).

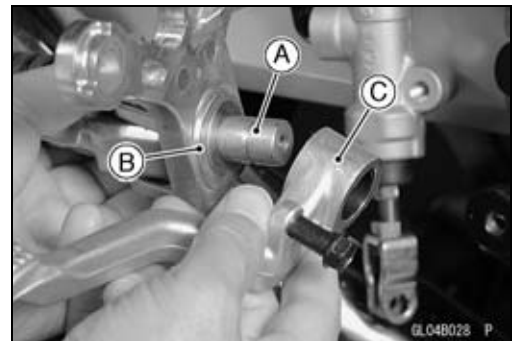

Calipers

Front Caliper Removal

- Remove the reflectors (for the US and Canadian models).
- Loosen the banjo bolt [A] at the brake hose lower end, and tighten it loosely.
- Unscrew the caliper mounting bolts [B], and detach the caliper [C] from the disc.

CAUTION

Do not loosen the caliper assembly bolts [D]. Take out only the caliper mounting bolts for caliper removal. Loosening the caliper assembly bolts will cause brake fluid leakage.

- Unscrew the banjo bolt and remove the brake hose [E] from the caliper (see Brake Hose Removal/Installation).
ZX1200-B1/B2 [F]
ZX1200-B3 [G]

CAUTION

Immediately wash away any brake fluid that spills.

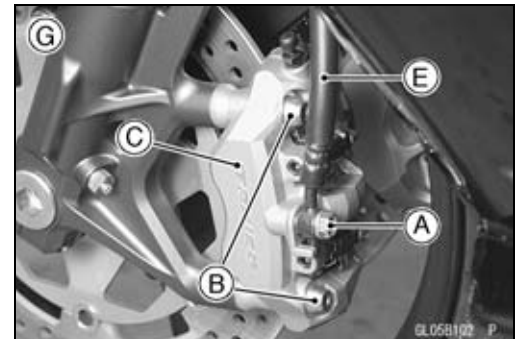
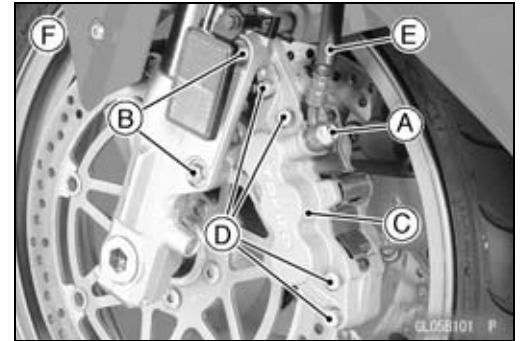

Rear Caliper Removal

- Loosen the banjo bolt [A] at the brake hose lower end, and tighten it loosely.
- Unscrew the caliper mounting bolts [B], and detach the caliper [C] from the disc.
- Unscrew the banjo bolt and remove the brake hose [D] from the caliper (see Brake Hose Removal/Installation).

CAUTION

Immediately wash away any brake fluid that spills.

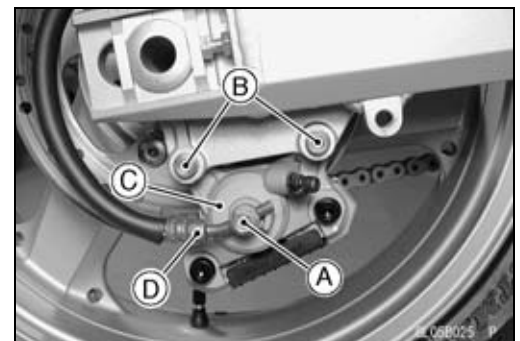

Caliper Installation

- Install the caliper and brake hose lower end.
- Replace the washers on each side of hose fitting with new ones.
- Tighten the caliper mounting bolts and banjo bolt.

Torque - Front Caliper Mounting Bolts: 34 N·m (3.5 kgf·m, 25 ft·lb)

Rear Caliper Mounting Bolts: 25 N·m (2.5 kgf·m, 18 ft·lb)

Brake Hose Banjo Bolt: 25 N·m (2.5 kgf·m, 18 ft·lb)

- Check the fluid level in the brake reservoirs.
- Bleed the brake line (see Bleeding the Brake Line).
- Check the brake for good braking power, no brake drag, and no fluid leakage.

⚠ WARNING

Do not attempt to drive the motorcycle until a full brake lever or pedal is obtained by pumping the brake lever or pedal until the pads are against the disc. The brakes will not function on the first application of the lever or pedal if this is not done.

12-12 BRAKES

Calipers

Front Caliper Disassembly

ZX1200-B1/B2

- Remove the pad spring and brake pads (see this chapter).
- Loosen the front caliper assembly bolts [A] and front caliper banjo bolt [B] and tighten them loosely.
- Remove the front caliper [C] and banjo bolt.
- Remove the front caliper assembly bolts and split the front caliper.
- Remove the O-rings.

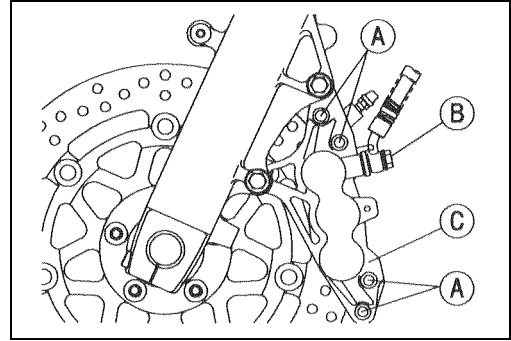

- Remove the pistons with compressed air as follows.
 - Install a rubber gasket [A] and a wooden board [B] more than 10 mm (0.40 in.) thick on the caliper half, and fasten them together with a suitable bolt and nut as shown. Leave one of the oil passages [C] open.
 - Lightly apply compressed air [D] to the oil passage until the pistons hit the rubber gasket. Block the hose joint opening [E] during this operation if the caliper half has the opening.
 - Bolt and Nut [F]
 - Oil Passage sealed by Rubber Gasket [G]
 - Push down [H]

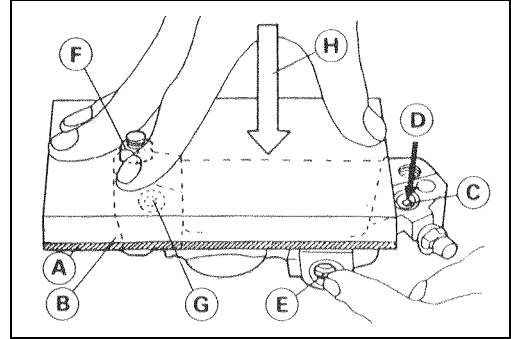

⚠ WARNING

To avoid serious injury, never place your fingers or palm in front of the piston. If you apply compressed air into the caliper, the piston may crush your hand or fingers.

- Pull out the pistons by hand.
 - Remove the dust seals [A] and fluid seals [B].
 - Remove the bleed valve [C], and rubber cap [D].
 - Repeat the previous step to remove the pistons from the other side of the caliper body.

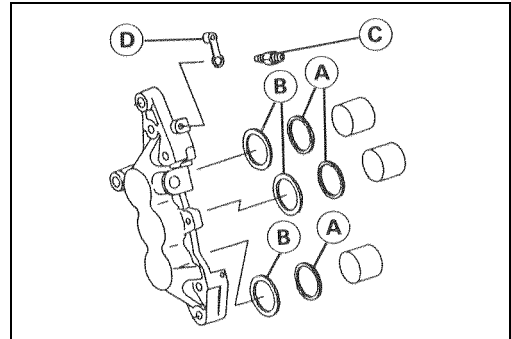

ZX1200-B3

- Loosen the front caliper pad pins [A] and banjo bolt [B] and tighten them loosely.

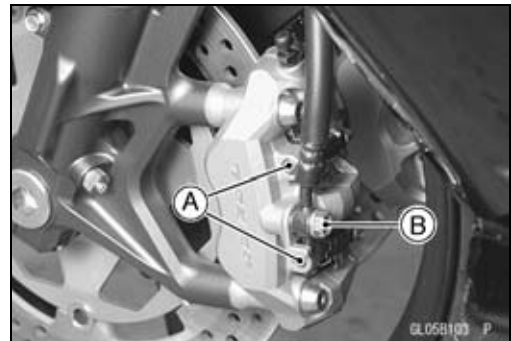

Calipers

- Remove the caliper of other side.
- Loosen the caliper assembly bolts [A].
- Remove:
 - Front Caliper (see Front Caliper Removal)
 - Brake Pad
 - Front Caliper Assembly Bolts
 - O-rings



- Using compressed air, remove the pistons. One way to remove the pistons is as follows.
 - Install a rubber gasket [A] and a wooden board [B] more than 10 mm (0.40 in.) thick on the caliper half, and fasten them together with a suitable bolt and nut as shown. Leave one of the oil passages [C] open.
 - Lightly apply compressed air [D] to the oil passage until the pistons hit the rubber gasket. Block the hose joint opening [E] during this operation if the caliper half has the opening.
 - Bolt and Nut [F]
 - Oil Passage Sealed by Rubber Gasket [G]
 - Push down [H]

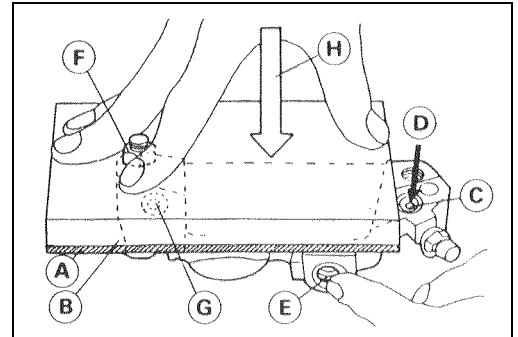

⚠ WARNING

To avoid serious injury, never place your fingers or palm in front of the piston. If you apply compressed air into the caliper, the piston may crush your hand or fingers.

- Pull out the pistons by hand.
- Remove the dust seals [A] and fluid seals [B].
- Remove the bleed valve [C] and rubber cap [D].
- Repeat the previous step to remove the pistons from the other side of the caliper body.

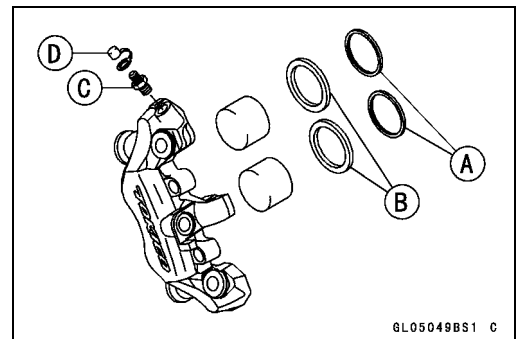

NOTE

- If compressed air is not available, do as follows for both calipers coincidentally, with the brake hose connected to the caliper.
- Prepare a container for brake fluid, and perform the work above it.
- Remove the spring and pads (see Front Brake Pad Removal).
- Pump the brake lever until the pistons come out of the cylinders, and then disassemble the caliper.

Front Caliper Assembly

- Clean the caliper parts except for the pads.

CAUTION

For cleaning the parts, use only disc brake fluid, isopropyl alcohol, or ethyl alcohol.

- Install the bleed valve and rubber cap.
 - Torque - Bleed Valve: 7.8 N·m (0.80 kgf·m, 69 in·lb)

12-14 BRAKES

Calipers

- Replace the fluid seals [A] with new ones.
- Apply brake fluid to the fluid seals, and install them into the cylinders by hand.
- Replace the dust seals [B] with new ones if they are damaged.
- Apply brake fluid to the dust seals, and install them into the cylinders by hand.

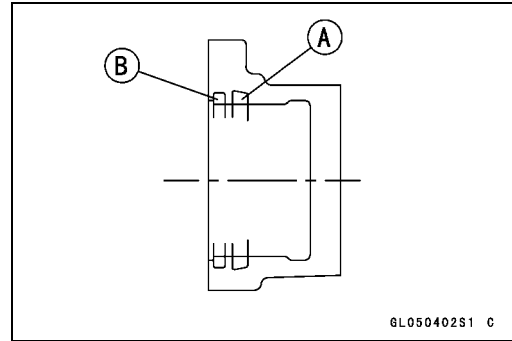

ZX1200-B1/B2

- Replace the O-rings [A] if they are damaged.
- Apply brake fluid to the outside of the pistons, and push them into each cylinder by hand.
- Be sure to install the O-rings.
- Tighten the caliper assembly bolts.

Torque - Front Caliper Assembly Bolts: 21 N·m (2.1 kgf·m, 15 ft·lb)

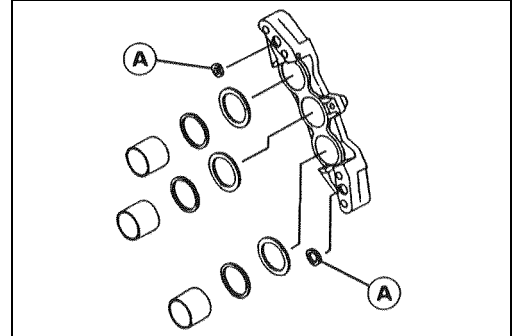

- Install the pads (see Front Brake Pad Installation).
- Wipe up any spilled brake fluid on the caliper with wet cloth.
- Install the front calipers (see Front Caliper Installation).

ZX1200-B3

- Replace the O-ring [A].
- Apply brake fluid to the outside of the pistons, and push them into each cylinder by hand.
- Be sure to install the O-rings.
- Tighten the caliper assembly bolts.

Torque - Front Caliper Assembly Bolts: 21 N·m (2.1 kgf·m, 15 ft·lb)

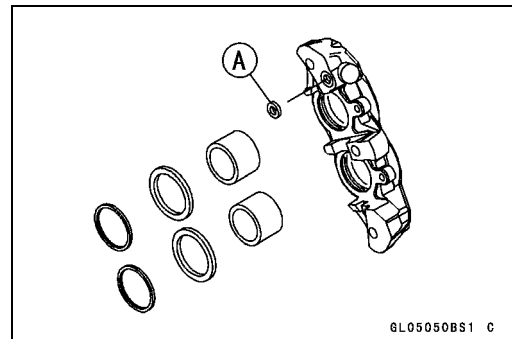

- Install the pads (see Front Brake Pad Installation).
- Wipe up any spilled brake fluid on the caliper with wet cloth.
- Install the front calipers (see Front Caliper Installation).

Rear Caliper Disassembly

- Loosen the banjo bolt [A] and rear caliper assembly bolts [B], and tighten them loosely.
- Remove:
 - Rear Caliper (see Rear Caliper Removal)
 - Brake Pads (see Rear Brake Pad Removal)
 - Rear Caliper Assembly Bolts
 - O-rings

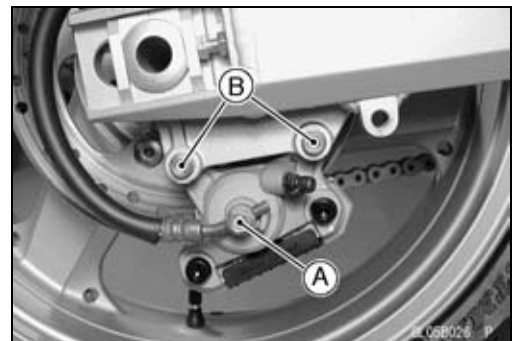

Calipers

- Remove the pistons, dust seals and fluid seals as same as front caliper disassembly.
 - Piston Completes [A]
 - Dust Seals [B]
 - Fluid Seals [C]
 - O-rings [D]
 - Caliper Body [E]
 - Caliper Assembly Bolts [F]
 - Bleed Valves [G]
 - Rubber Caps [H]

⚠ WARNING

To avoid serious injury, never place your fingers or palm in rear of the piston. If you apply compressed air into the caliper, the piston may crush your hand of fingers.

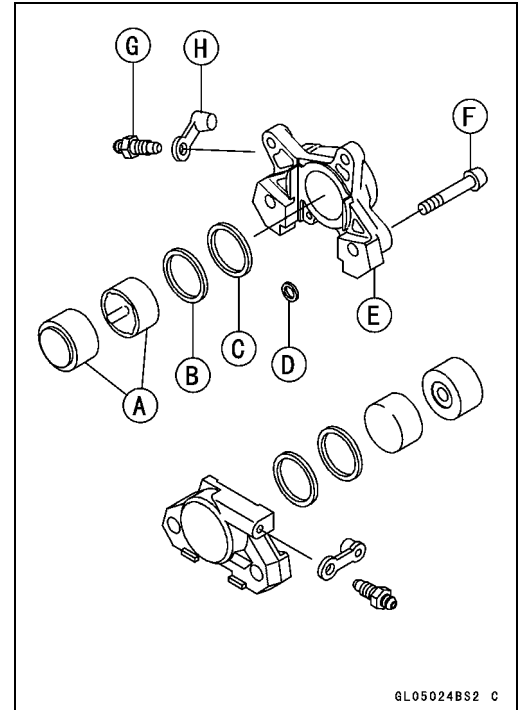

Rear Caliper Assembly

- Clean the caliper parts except for the pads.

CAUTION

For cleaning the parts, use only disc brake fluid, isopropyl alcohol, or ethyl alcohol.

- Install the bleed valve and rubber cap.
 - Torque - Bleed Valve: 7.8 N·m (0.80 kgf·m, 69 in·lb)**
- Replace the fluid seal [A] with a new one.
 - Apply brake fluid to the fluid seal, and install it into the cylinder by hand.
- Replace the dust seal [B] with a new one if it is damaged.
 - Apply brake fluid to the dust seal, and install it into the cylinder by hand.
- Replace the O-ring [A] if it is damaged.
- Apply brake fluid to the outside of the piston, and push it into the cylinder by hand.
- Install the piston insulator.
- Tighten the caliper assembly bolts.
 - Torque - Rear Caliper Assembly Bolts: 30 N·m (3.0 kgf·m, 22 ft·lb)**

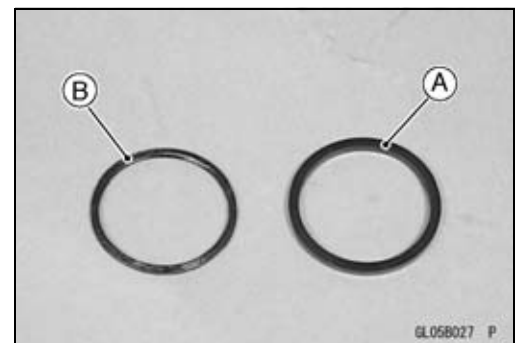

- Install the pads (see Rear Brake Pad Installation).
- Wipe up any spilled brake fluid on the caliper with wet cloth.
- Install the rear caliper (see Rear Caliper Installation).

12-16 BRAKES

Calipers

Caliper Fluid Seal Damage

ZX1200-B1/B2

The fluid seals [C] around the pistons [A] maintain the proper pad/disc clearance. If the seals are not satisfactory, pad wear will increase, and constant pad drag on the disc will raise brake and brake fluid temperature.

- Replace the fluid seals under any of the following conditions; (a) fluid leakage around the pad; (b) brakes overheat (c) there is a large difference in inner and outer pad wear; (d) the seal is stuck to the piston.
- ★ If the fluid seal is replaced, replace the dust seal [B] as well. Also, replace all seals every other time the pads are changed.

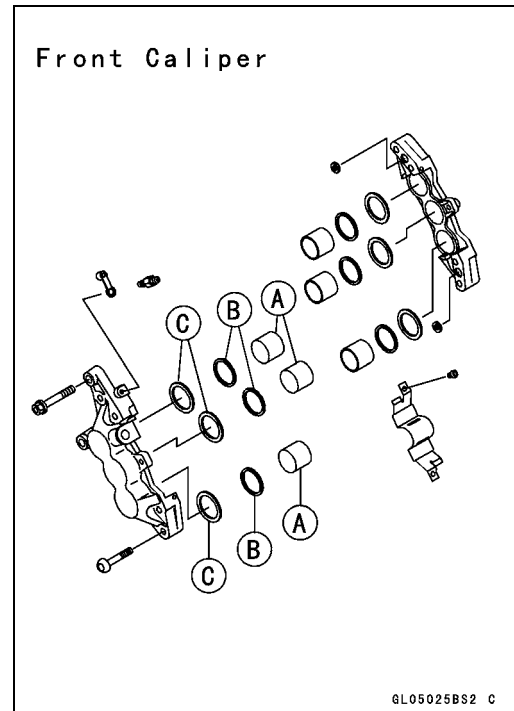

ZX1200-B3

The fluid seals (piston seal) [A] is placed around the piston to maintain clearance between the pad and the disc. If the seal is in a poor condition, it could lead the pad to wear excessively or the brake to drag, which may cause the temperature of the discs or the brake fluid to increase.

- Replace the fluid seal if it exhibits any of the conditions listed below.
 - Brake fluid leakage around the pad.
 - Brakes overheat.
 - Considerable difference in inner and outer pad wear.
 - Seal and piston are stuck together.
- ★ If the fluid seal is replaced, replace the dust seals [B] as well. Also, replace all seals every other time the pads are changed.

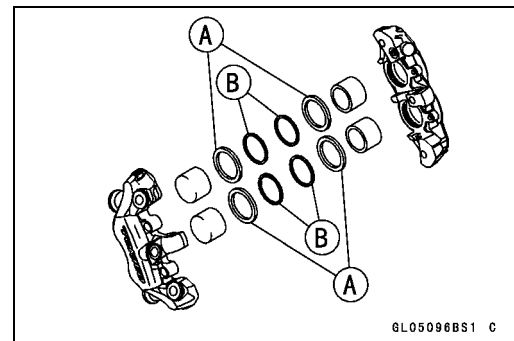

Calipers

Caliper Dust Seal Damage

- Check that the dust seals [B] is not cracked, worn, swollen, or otherwise damaged.
- If it show any damage, remove the caliper bracket and replace it.
 - Pistons [A]
 - Fluid Seals [C]

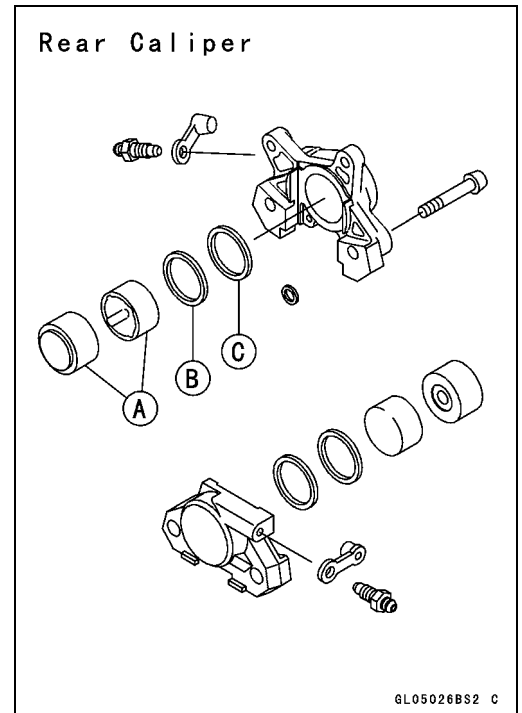

Caliper Piston and Cylinder Damage

- Visually inspect the pistons and cylinder surfaces.
- ★ Replace the caliper if the cylinder and piston are badly scores or rusty.

12-18 BRAKES

Brake Pads

Front Brake Pad Removal

ZX1200-B1/B2

- Unscrew the pad spring bolts [A], and remove the pad spring [B].

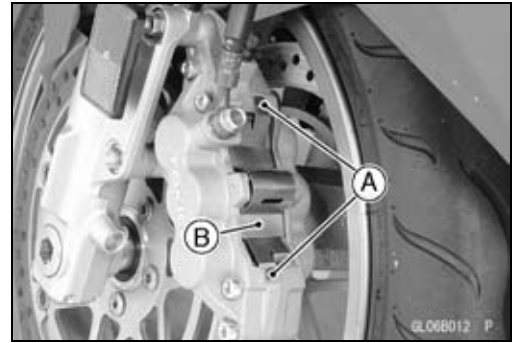

- Draw out the clip [A], and take off the pad pin [B].
- Remove the brake pads [C].

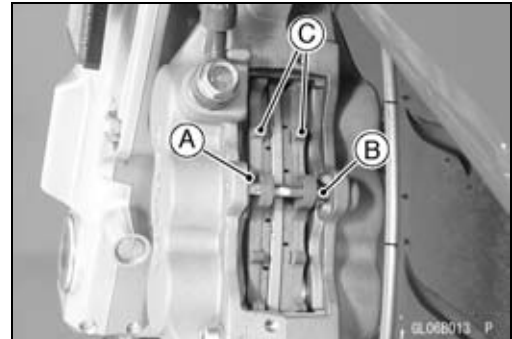

ZX1200-B3

- Loosen:
Pad Pins [B]
- Remove:
Caliper Mounting Bolts [A]

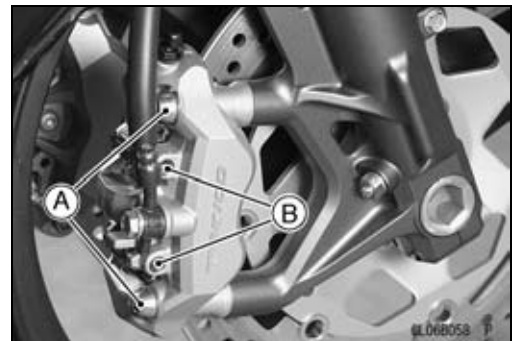

- Remove:
Pad Pin [A]
Pad Spring [B]
Brake Pads [C]

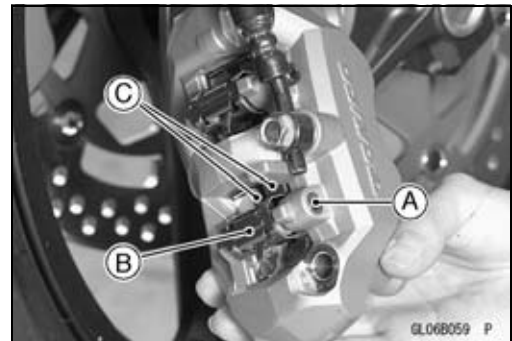

Brake Pads

Front Brake Pad Installation

ZX1200-B1/B2

- Push the caliper pistons in by hand as far as they will go.
- Install the brake pads.
- Install the pad pin and clip. The clip must be "outside" of the pads.
- Install the caliper (see Front Caliper Installation).

Torque - Front Brake Pad Spring Bolts: 3.0 N·m (0.30 kgf·m, 27 in·lb)

⚠ WARNING

Do not attempt to drive the motorcycle until a full brake lever is obtained by pumping the brake lever until the pads are against the disc. The brake will not function on the first application of the lever if this is not done.

ZX1200-B3

- Push the caliper pistons in by hand as far as they will go.
- Install the outside pad [A] and insert the pin [B] as shown.

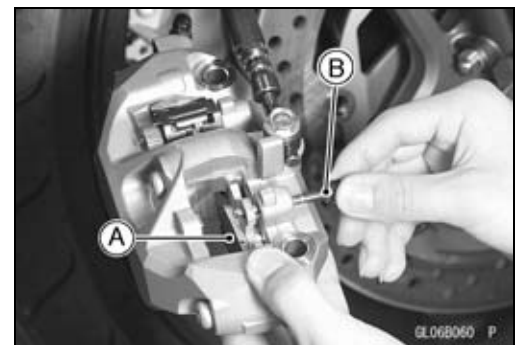

- Set:
 - Inside Pad [A]
 - Pad Spring [B]
- Pushing the pin holder [C] to hole of the pad and insert the pin.

Torque - Front Brake Pad Pins: 15 N·m (1.5 kgf·m, 11 ft·lb)

⚠ WARNING

Do not attempt to drive the motorcycle until a full brake lever is obtained by pumping the brake lever and the pads are against the disc. The brake will not function on the first application of the lever if this is not done.

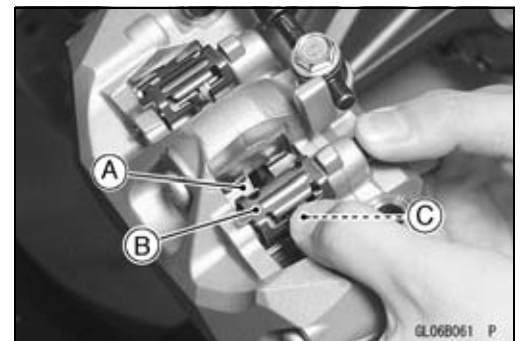

Rear Brake Pad Removal

- Unscrew the caliper mounting bolts.
- Detach the caliper from the disc.
- Remove the piston pad cover [A].
- Draw out the clip [B] upward.

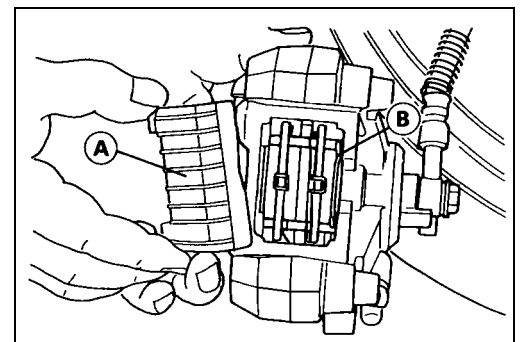

12-20 BRAKES

Brake Pads

- Pushing either ends [A] of the pad spring lightly, take off the pad pins [B] one by one.
- Remove the pad springs [C] and brake pads.

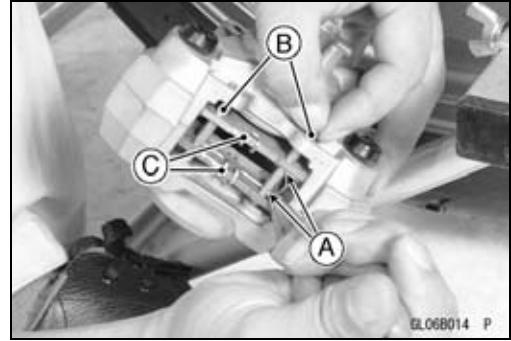

Rear Brake Pad Installation

- Push the caliper piston in by hand as far as it will go.
- Put the pads [A] in the caliper to insert either pin [B] into both holes of pad.
- Put the anti-rattle springs [C] under inserted pins.
- Insert other side pad pin [E] into both holes of pad with pushing both spring ends [D].

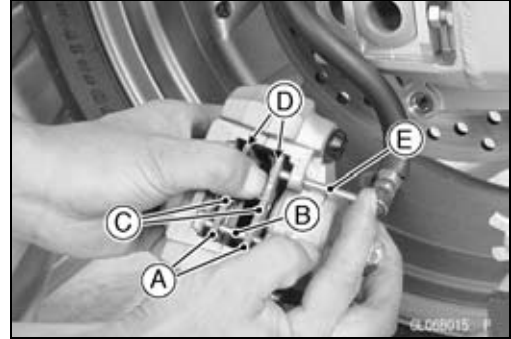

- Insert the clip [A]. The clip must be "outside" of the pads.
- Install the caliper (see Rear Caliper Installation).

⚠ WARNING

Do not attempt to drive the motorcycle until a full brake pedal is obtained by pumping the brake pedal until the pads are against the disc. The brake will not function on the first application of the pedal if this is not done.

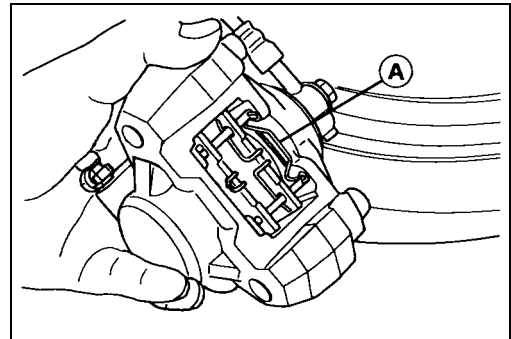

Brake Pad Lining Wear

- Refer to the Brake Pad Wear Inspection in the Periodic Maintenance chapter.

Master Cylinder

Front Master Cylinder Removal

- Disconnect the front brake light switch connectors [A].
- Remove the banjo bolt [B] to disconnect the brake hose from the master cylinder [C] (see Brake Hose Removal/Installation).

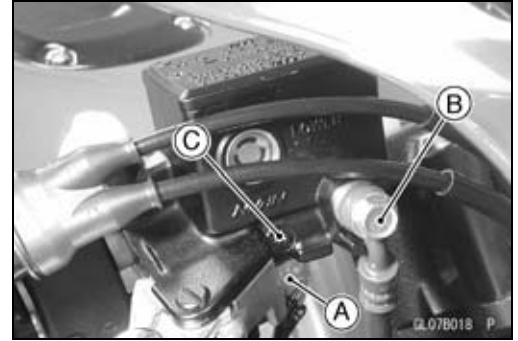

- Unscrew the clamp bolts [A], and take off the master cylinder as an assembly with the reservoir, brake lever, and brake switch installed.



Front Master Cylinder Installation

- Install the front master cylinder so that the punch mark [A] of the handlebar is aligned with the mating surface [B] of the master cylinder clamp to level the reservoir.

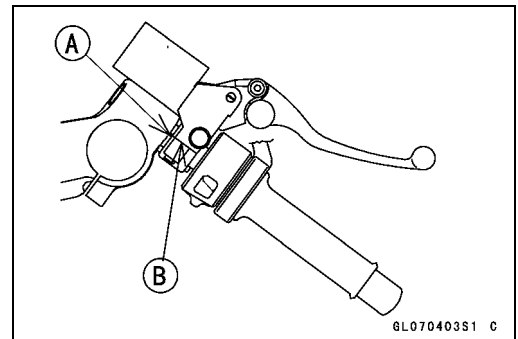

- The master cylinder clamp must be installed with the arrow mark [A] upward.
- Tighten the upper clamp bolt [B] first, and then the lower clamp bolt [C]. There will be a gap at the lower part of the clamp after tightening.

Torque - Front Master Cylinder Clamp Bolts: 8.8 N·m (0.90 kgf·m, 78 in·lb)

- Replace the washers on each side of the hose fitting with new ones.
- Tighten the brake hose banjo bolt.

Torque - Brake Hose Banjo Bolt: 25 N·m (2.5 kgf·m, 18 ft·lb)

- Bleed the brake line (see Bleeding the Brake Line).
- Check the brake for good braking power, no brake drag, and no fluid leakage.

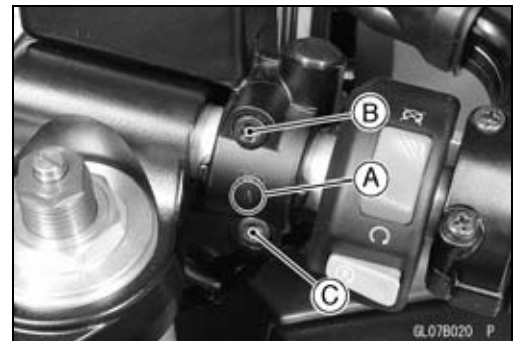

12-22 BRAKES

Master Cylinder

Rear Master Cylinder Removal

- Unscrew the brake hose banjo bolt [A] on the master cylinder (see Brake Hose Removal/Installation).
- Pull off the reservoir hose lower end [B], and drain the brake fluid into a container.
- Loosen the master cylinder mounting bolts [C] lightly.
- Remove the cotter pin [D].

NOTE

○ Pull off the joint pin while pressing down the brake pedal.

- Unscrew the master cylinder mounting bolts, and remove the master cylinder.

Rear Master Cylinder Installation

- Replace the cotter pin [A] with a new one.
- Replace the washers on each side of hose fitting with new ones.
- Tighten the following bolts.

Torque - Rear Master Cylinder Mounting Bolts: 25 N·m (2.5 kgf·m, 18 ft·lb)

Brake Hose Banjo Bolt: 25 N·m (2.5 kgf·m, 18 ft·lb)

- Bleed the brake line (see Bleeding the Brake Line).
- Check the brake for good braking power, no brake drag, and no fluid leakage.

Front Master Cylinder Disassembly

- Remove the front master cylinder (see Front Master Cylinder Removal).
- Remove the reservoir cap and diaphragm, and pour the brake fluid into a container.
- Unscrew the locknut and pivot bolt, and remove the brake lever.
- Pull the dust cover [A] out of place, and remove the circlip [B].

Special Tool - Inside Circlip Pliers: 57001-143

- Pull out the piston [C], secondary cup [D], primary cup [E], and return spring [F].

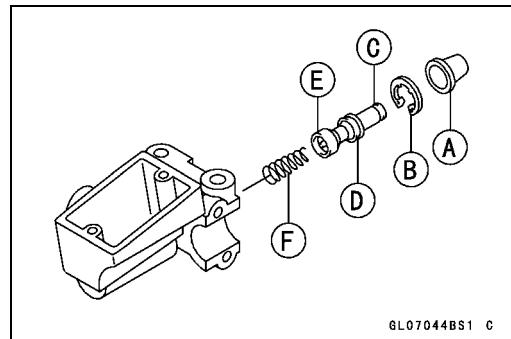
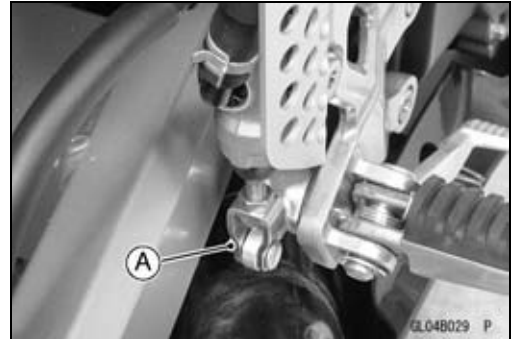
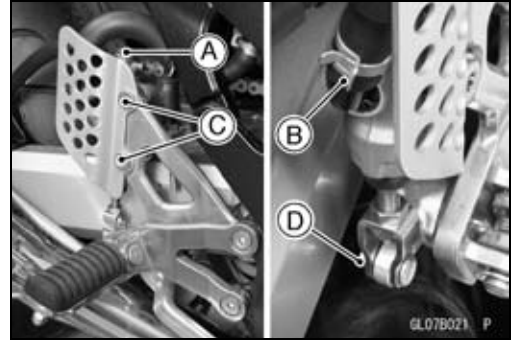

CAUTION

Do not remove the secondary cup from the piston since removal will damage it.

Master Cylinder

Rear Master Cylinder Disassembly

- Remove the rear master cylinder (see Rear Master Cylinder Removal).
- Slide the dust cover [F] on the push rod out of place, and remove the circlip [E].

Special Tool - Inside Circlip Pliers: 57001-143

NOTE

○ Do not remove the push rod clevis [G] for master cylinder disassembly since removal requires brake pedal position adjustment.

- Pull out the push rod with the piston stop.
- Take off the piston [A], secondary cup [B], primary cup [C], and return spring [D].

CAUTION

Do not remove the secondary cup from the piston since removal will damage it.

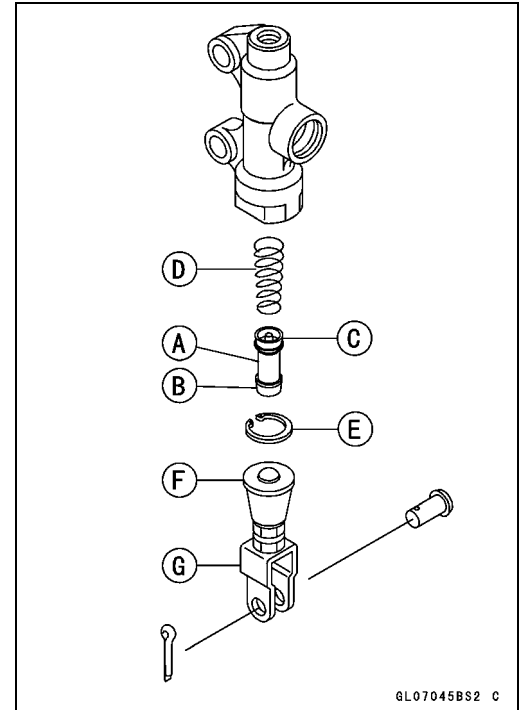

Master Cylinder Assembly

- Before assembly, clean all parts including the master cylinder with brake fluid or alcohol.

CAUTION

Except for the disc pads and disc, use only disc brake fluid, isopropyl alcohol, or ethyl alcohol for cleaning brake parts. Do not use any other fluid for cleaning these parts, Gasoline, engine oil, or any other petroleum distillate will cause deterioration of the rubber parts. Oil Spilled on any part will be difficult to wash off completely, and will eventually deteriorate the rubber used in the disc brake.

- Apply brake fluid to the removed parts and to the inner wall of the cylinder.
- Take care not to scratch the piston or the inner wall of the cylinder.
- Apply silicone grease (ex. PBC grease) to the push rod end, the brake lever end (piston contact portion) and the brake lever pivot bolt journal.
- Tighten the brake lever pivot bolt and the locknut.

Torque - Brake Lever Pivot Bolt: 1.0 N·m (0.10 kgf·m, 9 in·lb)

Brake Lever Pivot Bolt Locknut: 6.0 N·m (0.60 kgf·m, 52 in·lb)

12-24 BRAKES

Master Cylinder

Master Cylinder Inspection (Visual Inspection)

- Disassemble the front and rear master cylinders.
- Check that there are no scratches, rust or pitting on the inner wall of each master cylinder [A] and on the outside of each piston [B].
- ★ If a master cylinder or piston shows any damage, replace them.
- Inspect the primary [C] and secondary [D] cups.
- ★ If a cup is worn, damaged, softened (rotted), or swollen, the piston assembly should be replaced to renew the cups.
- ★ If fluid leakage is noted at the brake lever, the piston assembly should be replaced to renew the cups.

Front Master Cylinder [J]

- Check the dust covers [E] for damage.
- ★ If they are damaged, replace them.
- Check the piston return springs [F] for any damage.
- ★ If the springs are damaged, replace them.
- Check that relief [G] and supply [H] ports are not plugged.
- ★ If the relief port becomes plugged, the brake pads will drag on the disc. Blow the ports clean with compressed air.

Rear Master Cylinder [K]

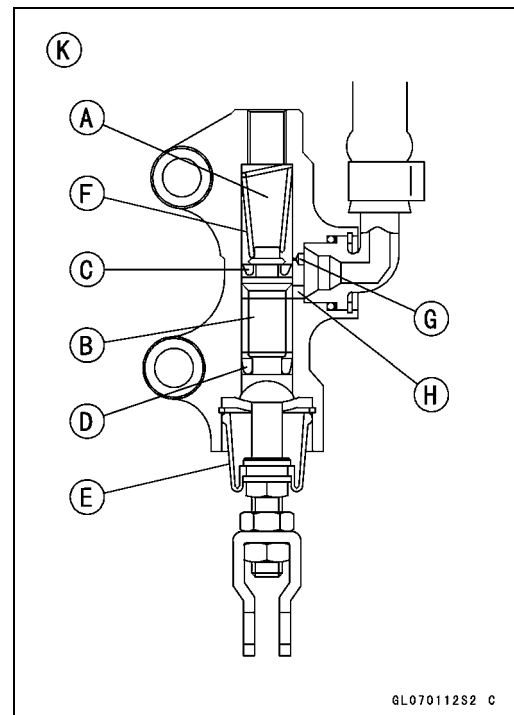
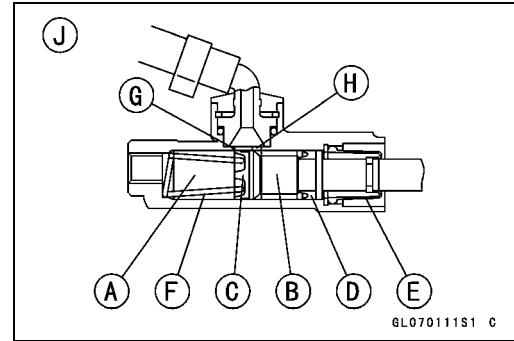

Brake Discs

Brake Disc Removal

- Remove the wheel (see Wheels/Tires chapter).
- Unscrew the mounting bolts [A], and take off the disc [B].

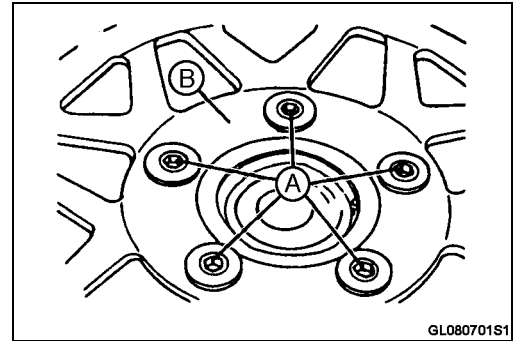

Brake Disc Installation

- Install the brake disc on the wheel so that the marked [A] side faces out.
- Apply a non-permanent locking agent to the threads of the rear brake disc mounting bolts.
- Tighten the mounting bolts [B].

Torque - Brake Disc Mounting Bolts: 27 N·m (2.8 kgf·m, 20 ft·lb)

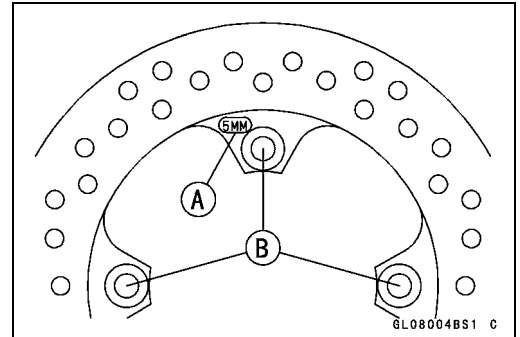

Brake Disc Wear

- Measure the thickness of each disc at the point where it has worn the most.
 - ★ Replace the disc [A] if it has worn past the service limit.
- Measuring Area [B]

Front Disc Thickness

Standard:

ZX1200-B1/B2 4.8 ~ 5.1 mm (0.19 ~ 0.20 in.)

ZX1200-B3 5.8 ~ 6.2 mm (0.23 ~ 0.24 in.)

Service Limit:

ZX1200-B1/B2 4.5 mm (0.18 in.)

ZX1200-B3 5.5 mm (0.22 in.)

Rear Disc Thickness

Standard:

ZX1200-B1/B2 5.8 ~ 6.0 mm (0.23 ~ 0.24 in.)

ZX1200-B3 5.9 ~ 6.1 mm (0.23 ~ 0.24 in.)

Service Limit: 5.0 mm (0.20 in.)

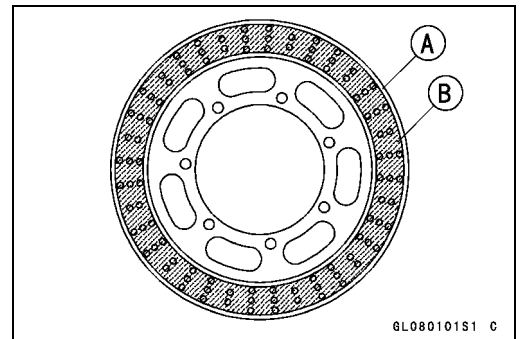

Brake Disc Warp

- Jack up the motorcycle so that the wheel is off the ground.
- Special Tool - Jack: 57001-1238**
- For front disc inspection, turn the handlebar fully to one side.
- Set up a dial gauge against the disc [A] as shown and measure disc runout.
- Turn the wheel by hand. [B]
- ★ If runout exceeds the service limit, replace the disc.

Disc Runout

Standard: 0.15 mm (0.0059 in.) or less

Service Limit: 0.3 mm (0.01 in.)

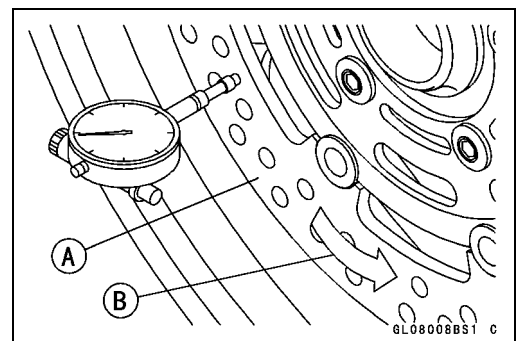

12-26 BRAKES

Brake Fluid

Brake Fluid Level Inspection

- Refer to the Brake Fluid Level Inspection in the Periodic Maintenance chapter.

Brake Fluid Change

- Refer to the Brake Fluid Change in the Periodic Maintenance chapter.

Bleeding the Brake Line

The brake fluid has a very low compression coefficient so that almost all the movement of the brake lever or pedal is transmitted directly to the caliper for braking action. Air, however, is easily compressed. When air enters the brake lines, brake lever or pedal movement will be partially used in compressing the air. This will make the lever or pedal feel spongy, and there will be a loss in braking power.

▲ WARNING

Be sure to bleed the air from the brake line whenever brake lever or pedal action feels soft or spongy after the brake fluid is changed, or whenever a brake line fitting has been loosened for any reason.

NOTE

○ *The procedure to bleed the front brake line is as follows. Bleeding the rear brake line is the same as for the front brake.*

- Remove the reservoir cap, and diaphragm.
 - Fill the reservoir with fresh brake fluid to the upper level line in the reservoir.
 - With the reservoir cap off, slowly pump the brake lever several times until no air bubbles can be seen rising up through the fluid from the holes at the bottom of the reservoir.
- Bleed the air completely from the master cylinder by this operation.
- Remove the rubber cap from the bleed valve on the caliper.
 - Attach a clear plastic hose to the bleed valve, and run the other end of the hose into a container.
 - Bleed the brake line and the caliper as follows:
- Repeat this operation until no more air can be seen coming out into the plastic hose.
1. Pump the brake lever until it becomes hard, and apply the brake and hold it [A].
 2. Quickly open and close [B] the bleed valve while holding the brake applied.
 3. Release the brake [C].

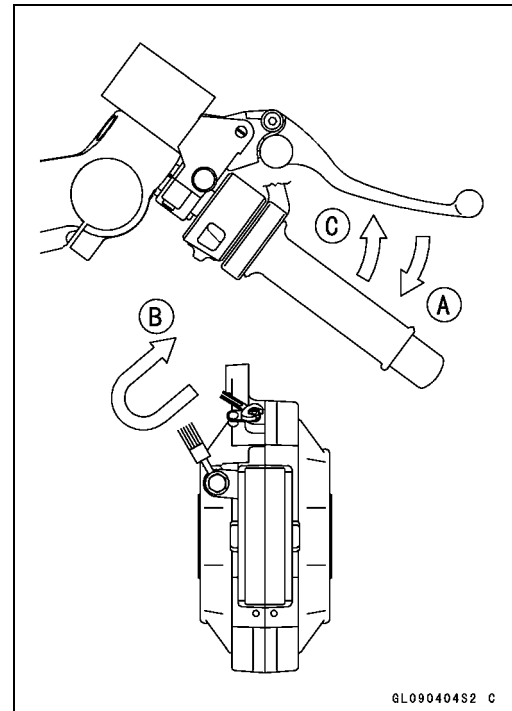

Brake Fluid

NOTE

- *The fluid level must be checked often during the bleeding operation and replenished with fresh brake fluid as necessary. If the fluid in the reservoir runs completely out any time during bleeding, the bleeding operation must be done over again from the beginning since air will have entered the line.*
 - *Tap the brake hose lightly from the caliper to the reservoir for more complete bleeding.*
 - *Front Brake: Repeat the above steps for the other caliper.*
 - *Rear Brake: Repeat the above steps for the other bleed valve.*
-
- Remove the clear plastic hose.
 - Install the reservoir cap.
 - Tighten the front reservoir cap screws.
Torque - Front Reservoir Cap Screws: 1.5 N·m (0.15 kgf·m, 13 in·lb)
 - Tighten the bleed valve, and install the rubber cap.
Torque - Bleed Valve: 7.8 N·m (0.80 kgf·m, 69 in·lb)
 - Check the fluid level.
 - After bleeding is done, check the brake for good braking power, no brake drag, and no fluid leakage.

12-28 BRAKES

Brake Fluid

WARNING

When working with the disc brake, observe the precautions listed below.

1. Never reuse old brake fluid.
2. Do not use fluid from a container that has been left unsealed or that has been open for a long time.
3. Do not mix two types and brands of fluid for use in the brake. This lowers the brake fluid boiling point and could cause the brake to be ineffective. It may also cause the rubber brake parts to deteriorate.
4. Don't leave the reservoir cap off for any length of time to avoid moisture contamination of the fluid.
5. Don't change the fluid in the rain or when a strong wind is blowing.
6. Except for the disc pads and disc, use only disc brake fluid, isopropyl alcohol, or ethyl alcohol for cleaning brake parts. Do not use any other fluid for cleaning these parts. Gasoline, engine oil, or any other petroleum distillate will cause deterioration of the rubber parts. Oil spilled on any part will be difficult to wash off completely and will eventually deteriorate the rubber used in the disc brake.
7. When handling the disc pads or disc, be careful that no disc brake fluid or any oil gets on them. Clean off any fluid or oil that inadvertently gets on the pads or disc with a high-flash point solvent. Do not use one which will leave an oily residue. Replace the pads with new ones if they cannot be cleaned satisfactorily.
8. Brake fluid quickly ruins painted surfaces; any spilled fluid should be completely wiped up immediately.
9. If any of the brake line fittings or the bleed valve is opened at any time, the **AIR MUST BE BLED FROM THE BRAKE LINE.**

Brake Hoses

Brake Hose Removal/Installation

CAUTION
Brake fluid quickly ruins painted or plastic surfaces; any spilled fluid should be completely wiped up immediately with wet cloth.

- When removing the brake hose, take care not to spill the brake fluid on the painted or plastic parts.
- When removing the brake hose, temporarily secure the end of the brake hose to some high place to keep fluid loss to a minimum.
- There are washers on each side of the brake hose fitting. Replace them with new ones when installing.
- When installing the hoses, avoid sharp bending, kinking, flattening or twisting, and route the hoses according to Hose Routing section in General Information chapter.
- Tighten the banjo bolts at the hose fittings.

Torque - Brake Hose Banjo Bolts: 25 N·m (2.5 kgf·m, 18 ft·lb)

- Bleed the brake line after installing the brake hose (see Bleeding the Brake Line).

Brake Hose Inspection

- Refer to the Brake Hose, Connection Inspection in the Periodic Maintenance chapter.

Suspension

Table of Contents

Exploded View.....	13-2
Specifications	13-4
Front Fork.....	13-5
Rebound Damping Force Adjustment.....	13-5
Compression Damping Force Adjustment.....	13-5
Spring Preload Adjustment.....	13-6
Front Fork Removal (each fork leg).....	13-7
Front Fork Installation.....	13-7
Fork Oil Change.....	13-7
Front Fork Disassembly.....	13-8
Front Fork Assembly.....	13-8
Inner Tube Inspection.....	13-9
Dust Seal Inspection.....	13-10
Spring Tension.....	13-10
Rear Shock Absorber.....	13-11
Rebound Damping Force Adjustment.....	13-11
Compression Damping Force Adjustment.....	13-11
Spring Preload Adjustment.....	13-12
Rear Shock Absorber Removal.....	13-12
Rear Shock Absorber Installation.....	13-13
Rear Shock Absorber Scrapping.....	13-13
Swingarm.....	13-14
Swingarm Removal.....	13-14
Swingarm Installation.....	13-15
Swingarm Bearing Removal.....	13-15
Swingarm Bearing Installation.....	13-16
Swingarm Bearing, Sleeve Inspection.....	13-16
Swingarm Pivot Lubrication.....	13-16
Chain Slider Inspection.....	13-16
Tie-Rod, Rocker Arm.....	13-17
Tie-Rod Removal.....	13-17
Tie-Rod Installation.....	13-17
Rocker Arm Removal.....	13-17
Rocker Arm Installation.....	13-17
Needle Bearing Inspection.....	13-18
Tie-Rod, Rocker Arm Sleeve Inspection.....	13-18
Uni-track Linkage Lubrication.....	13-18

13-2 SUSPENSION

Exploded View

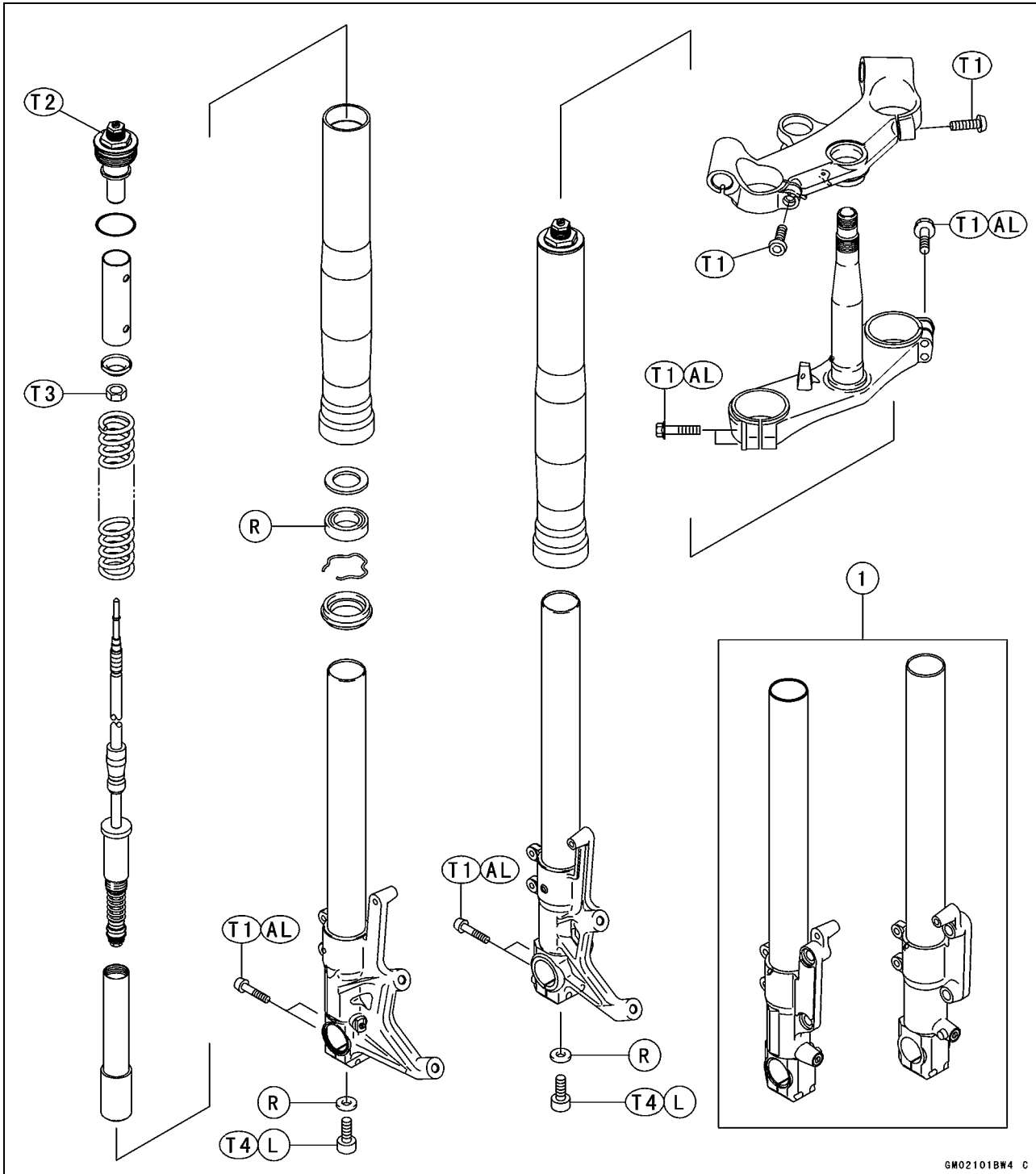

GM02101BW4 C

T1: 20 N·m (2.0 kgf·m, 15 ft·lb)

T2: 23 N·m (2.3 kgf·m, 17 ft·lb)

T3: 28 N·m (2.8 kgf·m, 21 ft·lb)

T4: 40 N·m (4.0 kgf·m, 30 ft·lb)

AL: Tighten the two clamp bolts alternately two times to ensure even tightening torque.

L: Apply a non-permanent locking agent.

R: Replacement Parts

Exploded View

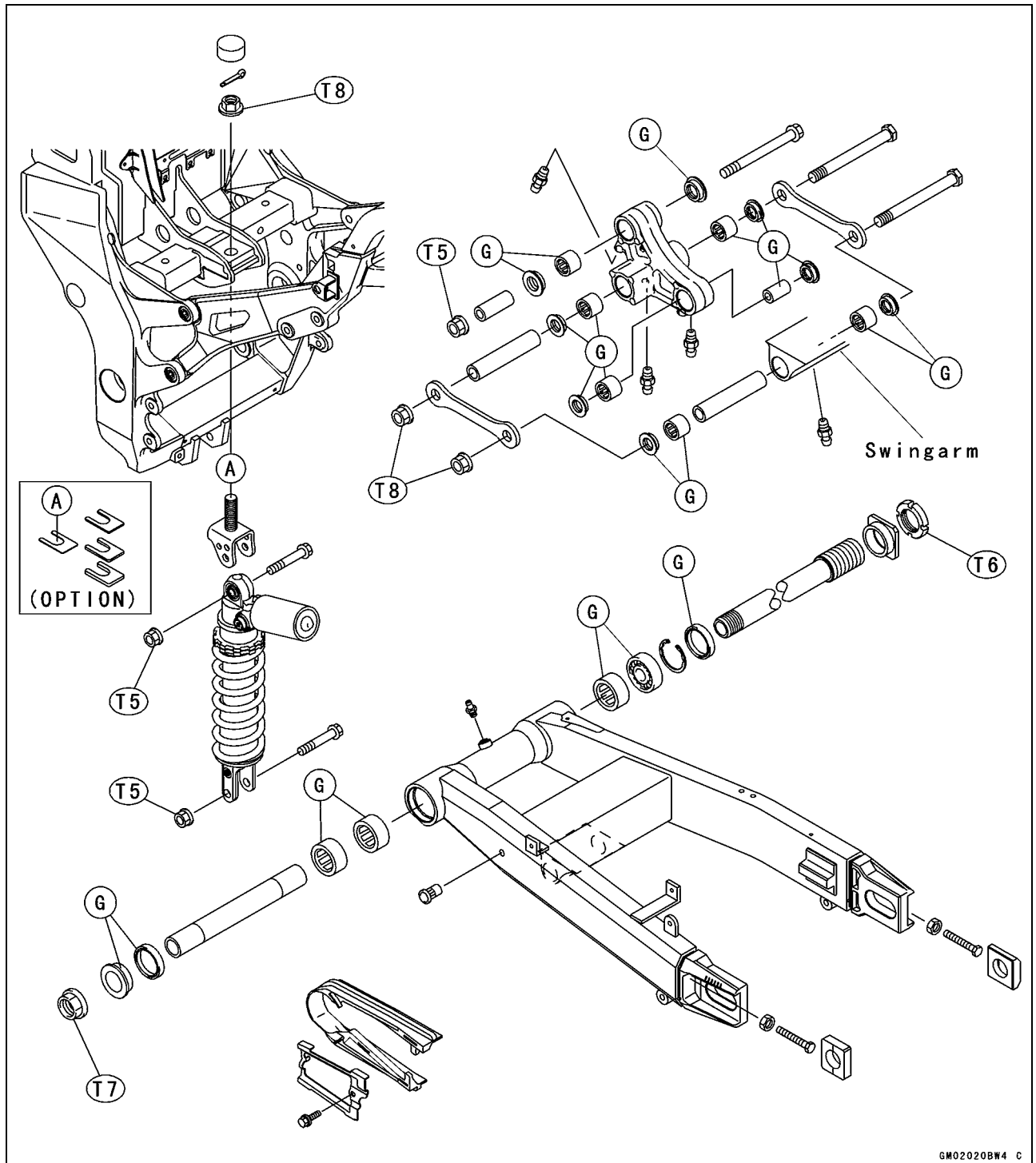

- T5: 34 N·m (3.5 kgf·m, 25 ft·lb)
- T6: 98 N·m (10 kgf·m, 72 ft·lb)
- T7: 125 N·m (13 kgf·m, 92 ft·lb)
- T8: 59 N·m (6.0 kgf·m, 44 ft·lb)
- G: Apply grease.

13-4 SUSPENSION

Specifications

Item	Standard
Front Fork (per One Unit)	
Fork Inner Tube Outside Diameter	φ43 mm (1.7 in.)
Air Pressure	Atmospheric pressure (Non-adjustable)
Rebound Damper Setting:	
ZX1200-B1/B2	1 1/2 turns backward from the fully tightened position (Usable Range: 0 ↔ 3 turns)
ZX1200-B3	7th click from the first click of the fully clockwise position (Usable Range: 0 ↔ 13 clicks)
Compression Damper Setting:	
ZX1200-B1/B2	2 1/4 turns backward from the fully tightened position (Usable Range: 0 ↔ 3 turns)
ZX1200-B3	17th click from the first click of the fully clockwise position (Usable Range: 0 ↔ 18 clicks)
Fork Spring Preload Setting	Adjuster protrusion is 17 mm (0.67 in.) (Usable Range: 4 ~ 19 mm (0.16 ~ 0.75 in.))
Fork Oil Viscosity	KAYABA KHL15-10 (SAE 0 W)
Fork Oil Capacity	490 ±4 mL (16.6 ±0.1 US oz) (completely dry) approx. 420 mL (14.2 US oz) (when changing oil)
Fork Oil Level	Fully compressed, without fork spring, below from outer tube top 93 ±2 mm (3.66 ±0.08 in.)
Fork Spring Free Length	251.5 mm (9.902 in.) (Service limit 246 mm (9.69 in.))
Rear Shock Absorber	
Rebound Damper Set	3 turns backward from the fully tightened position (Usable Range: 0 ↔ 5 turns)
Compression Damper Set	2 1/4 turns backward from the fully tightened position (Usable Range: 0 ↔ 5 turns)
Spring Setting Position:	
Standard	Spring length 177 mm (6.97 in.)
Usable Range	Spring length 191.5 mm (7.54 in.) to 170 mm (6.69 in.) (weaker to stronger)
Gas Pressure	980 kPa (10 kgf/cm ² , 142 psi, Non-adjustable)

Special Tools - Inside Circlip Pliers: 57001-143

Oil Seal and Bearing Remover: 57001-1058

Bearing Driver Set: 57001-1129

Jack: 57001-1238

Fork Piston Rod Puller, M12 × 1.25: 57001-1289

Fork Oil Level Gauge: 57001-1290

Front Fork Oil Seal Driver: 57001-1340

Socket Wrench: 57001-1370

Fork Cylinder Holder: 57001-1443

Fork Spring Compressor Set: 57001-1452

Hook Wrench: 57001-1512

Front Fork

Rebound Damping Force Adjustment

- To adjust the rebound damping force, turn the rebound damping adjuster [A] to suit you best.
- The standard adjuster setting for the average-build rider of 68 kg (150 lb) with no passenger and no accessories is the **1 1/2 turns backward** from the fully tightened position (ZX1200-B1/B2).
- The standard adjuster setting for the average-build rider of 68 kg (150 lb) with no passenger and no accessories is the 7th click from the first click of the fully clockwise position (ZX1200-B3).



⚠ WARNING

If both adjusters are not adjusted equally, handling may be impaired and a hazardous condition may result.

- The damping force can be left soft for average riding. But it should be adjusted harder for high speed riding or riding with a passenger. If the damping feels too soft or too stiff, adjust it in accordance with the following table.

Rebound Damping Force Adjustment ZX1200-B1/B2

Adjuster Position	Damping Force	Setting	Load	Road	Speed
3	Weak	Soft	Light	Good	Low
↑	↑	↑	↑	↑	↑
↓	↓	↓	↓	↓	↓
0	Strong	Hard	Heavy	Bad	High

ZX1200-B3

Adjuster Position	Damping Force	Setting	Load	Road	Speed
13	Weak	Soft	Light	Good	Low
↑	↑	↑	↑	↑	↑
↓	↓	↓	↓	↓	↓
0	Strong	Hard	Heavy	Bad	High

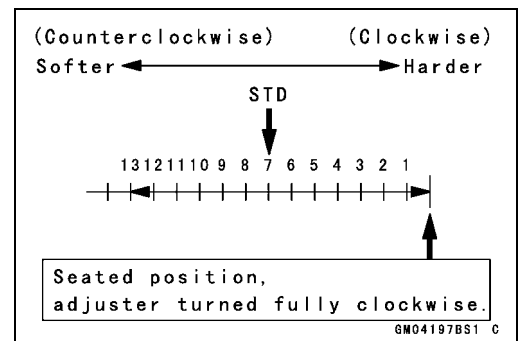
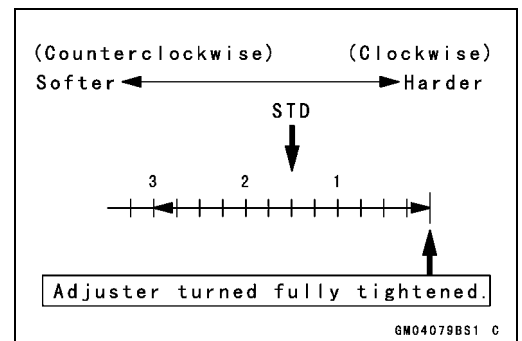

Compression Damping Force Adjustment

- To adjust the compression damping force, turn the compression damping adjuster [A] to suit you best.
- The standard adjuster setting for the average-build rider of 68 kg (150 lb) with no passenger and no accessories is the **2 1/4 turns backward** from the fully tightened position (ZX1200-B1/B2).
- The standard adjuster setting for the average-build rider of 68 kg (150 lb) with no passenger and no accessories is the 17th click from the first click of the fully clockwise position (ZX1200-B3).



⚠ WARNING

If both adjusters are not adjusted equally, handling may be impaired and a hazardous condition may result.

13-6 SUSPENSION

Front Fork

○The damping force can be left soft for average riding. But it should be adjusted harder for high speed riding or riding with a passenger. If the damping feels too soft or too stiff, adjust it in accordance with the following table.

Compression Damping Force Adjustment ZX1200-B1/B2

Adjuster Position	Damping Force	Setting	Load	Road	Speed
3	Weak	Soft	Light	Good	Low
↑	↑	↑	↑	↑	↑
↓	↓	↓	↓	↓	↓
0	Strong	Hard	Heavy	Bad	High

ZX1200-B3

Adjuster Position	Damping Force	Setting	Load	Road	Speed
18	Weak	Soft	Light	Good	Low
↑	↑	↑	↑	↑	↑
↓	↓	↓	↓	↓	↓
0	Strong	Hard	Heavy	Bad	High

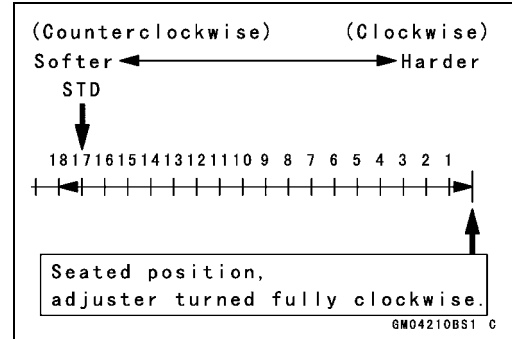
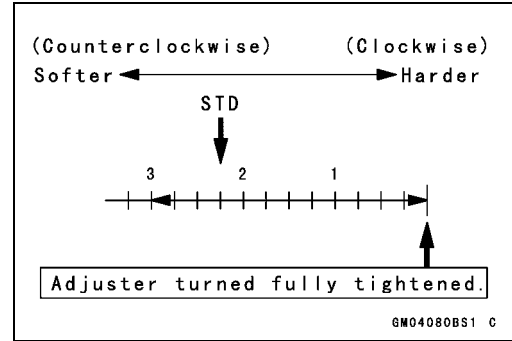

Spring Preload Adjustment

- Turn the spring preload adjuster [A] to change spring preload setting.
- The standard adjuster setting for the average-build rider of 68 kg (150 lb) with no passenger and no accessories is the 17 mm (0.67 in.) [B] from top as shown.

Adjuster Protrusion (from top)

- Standard: 17 mm (0.67 in.)
- Usable Range: 4 ~ 19 mm (0.16 ~ 0.75 in.)

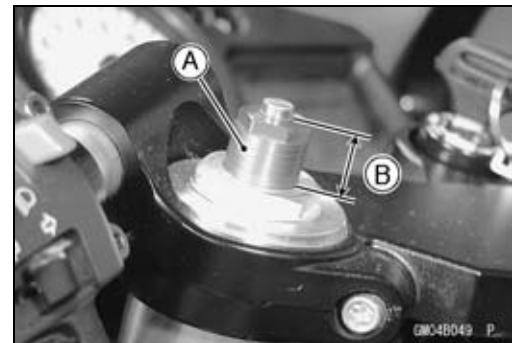

⚠ WARNING

If both adjusters are not adjusted equally, handling may be impaired and a hazardous condition may result.

○The spring preload can be left soft for average riding. But it should be adjusted harder for high speed riding or riding with a passenger. If the spring action feels too soft or too stiff, adjust it in accordance with the following table.

Spring Action

Adjuster Position	Damping Force	Setting	Load	Road	Speed
19 mm (0.75 in.)	Weak	Soft	Light	Good	Low
↑	↑	↑	↑	↑	↑
↓	↓	↓	↓	↓	↓
4 mm (0.16 in.)	Strong	Hard	Heavy	Bad	High

Front Fork

Front Fork Removal (each fork leg)

- Remove:
 - Front Wheel (see Wheels/Tires chapter)
 - Front Fender (see Frame chapter)
- ★ Loosen the upper fork clamp bolt [B] and fork top plug [A] beforehand if the fork leg is to be disassembled.

NOTE

- Loosen the top plug after loosening the upper fork clamp bolt.

- Loosen the upper fork clamp bolt [A] and lower fork clamp bolts [B].
- With a twisting motion, work the fork leg down and out.

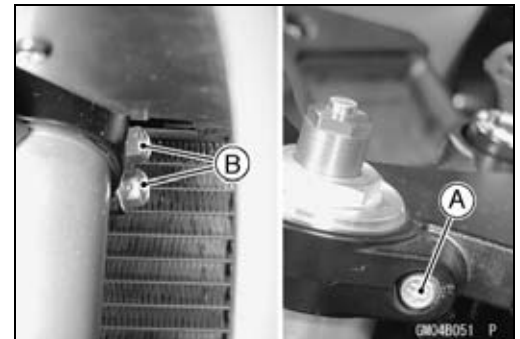

Front Fork Installation

- Install the fork so that the top end [A] of the outer tube is flush with the upper surface [B] of the steering stem head bracket.
- Tighten the lower fork clamp bolts and fork top plug.
 - Torque - Front Fork Clamp Bolts (Lower): 20 N·m (2.0 kgf·m, 15 ft·lb)**
 - Front Fork Top Plug: 23 N·m (2.3 kgf·m, 17 ft·lb)**

NOTE

- Tighten the two clamp bolts alternately two times to ensure even tightening torque.

- Tighten the upper fork clamp bolt.
 - Torque - Front Fork Clamp Bolt (Upper): 20 N·m (2.0 kgf·m, 15 ft·lb)**

NOTE

- Tighten the top plug before tightening the upper fork clamp bolt.

- Install the removed parts (see appropriate chapters).
- Adjust the spring preload and the damping force.

Fork Oil Change

The oil should be changed in accordance with the Periodic Maintenance chapter.

- Refer to the Front Fork Oil Change in the Periodic Maintenance chapter.

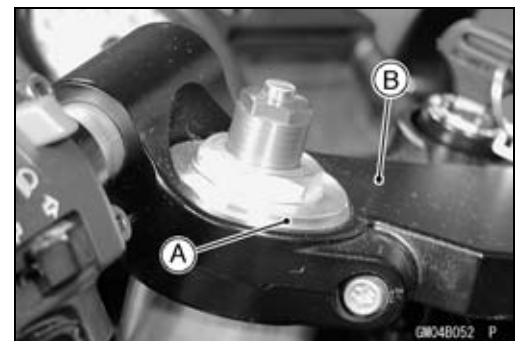

13-8 SUSPENSION

Front Fork

Front Fork Disassembly

- Remove the front fork (see Front Fork Removal).
- Drain the fork oil (see Fork Oil Change in the Periodic Maintenance chapter).
- Hold the front fork in a vise [A].
- Stop the cylinder [B] from turning by using the fork cylinder holder [C].

Special Tool - Fork Cylinder Holder: 57001-1443

- Unscrew the Allen bolt [D], then take the bolt and gasket out of the bottom of the inner tube.
- Take the cylinder unit [A].
- Do not disassemble the cylinder unit.

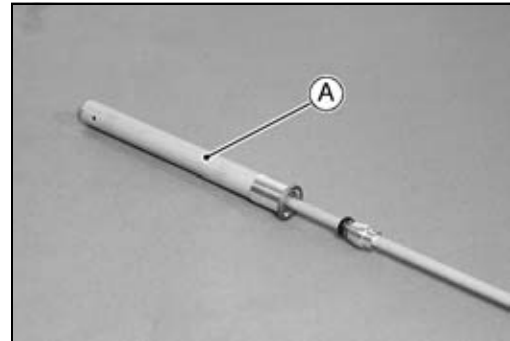
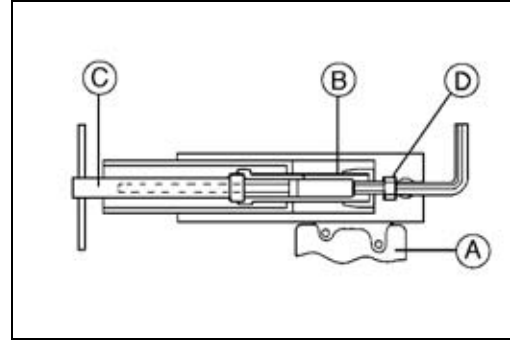

- Separate the outer tube from the inner tube.
- Pull out the dust seal.
- Remove the retaining ring [A] from the outer tube.
- Remove the oil seal [B] and washer [C].



Front Fork Assembly

- Replace the following parts with a new one.
 - Oil Seal
 - Bottom Allen Bolt Gasket
- Insert the cylinder unit [A] into the inner tube [B].
- Stop the cylinder from turning by using the fork cylinder holder.

Special Tool - Fork Cylinder Holder: 57001-1443

- Apply a non-permanent locking agent to the Allen bolt and tighten it.

Torque - Front Fork Bottom Allen Bolt: 40 N·m (4.0 kgf·m, 30 ft·lb)

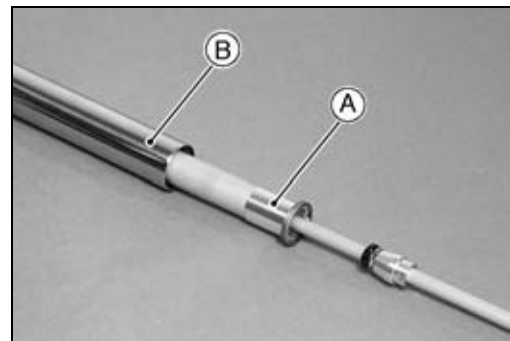

Front Fork

- Install the following parts into the inner tube [A].
 - Dust Seal [B]
 - Circlip [C]
 - Oil Seal [D]
 - Washer [E]

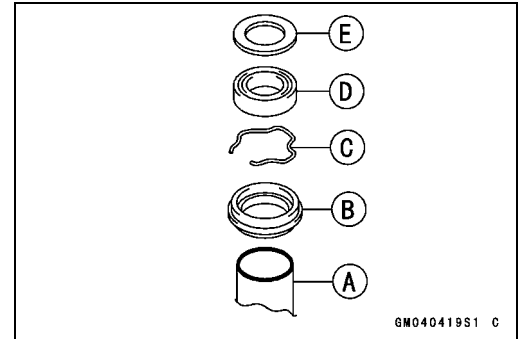

- Insert the inner tube to the outer tube.
- After installing the washer, install the oil seal [A] by using the fork oil seal driver [B].

Special Tool - Front Fork Oil Seal Driver: 57001-1340

- Install the circlip and dust seal.
- Pour in the specified type of oil (see Fork Oil Change in the Periodic Maintenance chapter).

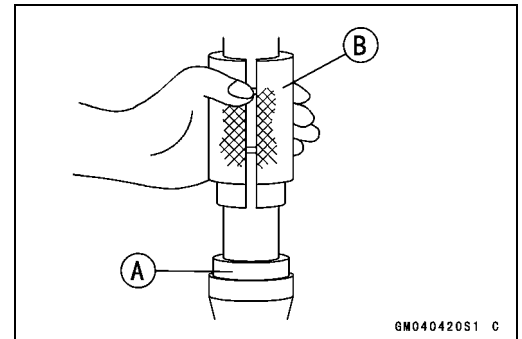

Inner Tube Inspection

- Visually inspect the inner tube [A], and repair any damage.
- Nicks or rust damage can sometimes be repaired by using a wet-stone to remove sharp edges or raised areas which cause seal damage.
- ★ If the damage is not repairable, replace the inner tube. Since damage to the inner tube damages the oil seal, replace the oil seal whenever the inner tube is repaired or replaced.

ZX1200-B1/B2 [B]

ZX1200-B3 [C]

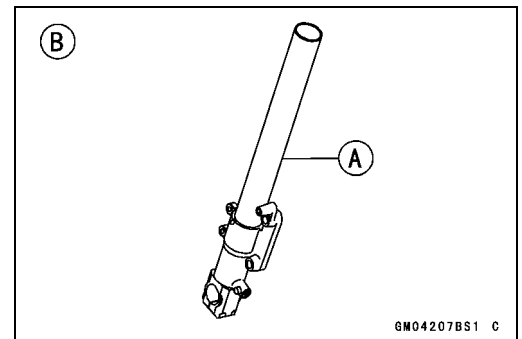

CAUTION
If the inner tube is badly bent or creased, replace it. Excessive bending, followed by subsequent straightening, can weaken the inner tube.

- Temporarily assemble the inner and outer tubes, and pump them back and forth manually to check for smooth operation.
- If you feel binding or catching, the inner and outer tubes must be replaced.

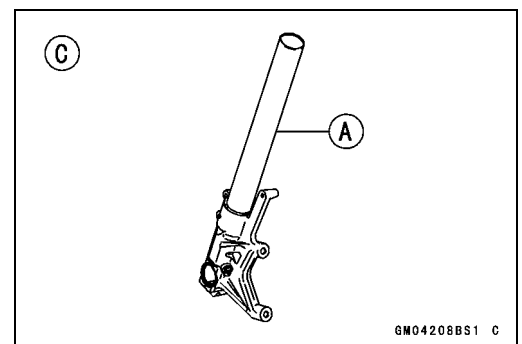

⚠ WARNING
A straightened inner or outer fork tube may fall in use, possibly causing an accident. Replace a badly bent or damaged inner or outer tube and inspect the other tube carefully before reusing it.

13-10 SUSPENSION

Front Fork

Dust Seal Inspection

- Inspect the dust seals [A] for any signs of deterioration or damage.
- ★ Replace it if necessary.

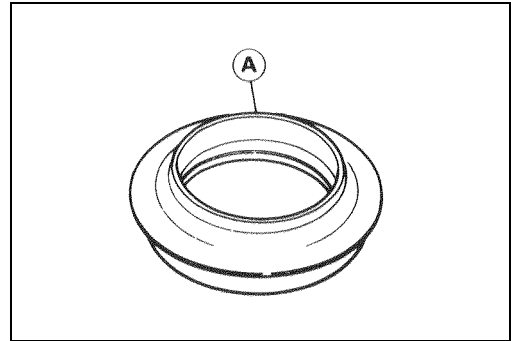

Spring Tension

- Since a spring becomes shorter as it weakens, check its free length [A] to determine its condition.
- ★ If the spring of either fork leg is shorter than the service limit, it must be replaced. If the length of a replacement spring and that of the remaining spring vary greatly, the remaining spring should also be replaced in order to keep the fork legs balanced for motorcycle stability.

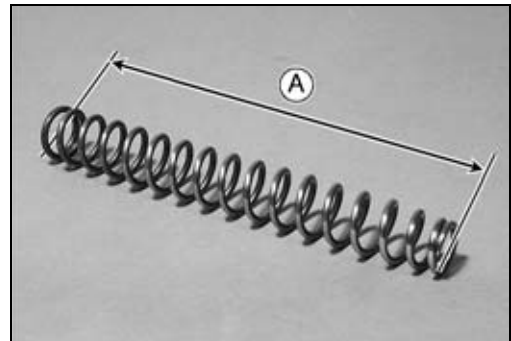

Spring Free Length

- Standard:** 251.5 mm (9.902 in.)
- Service Limit:** 246 mm (9.69 in.)

Rear Shock Absorber

Rebound Damping Force Adjustment

- To adjust the rebound damping force, turn the rebound damping adjuster [A] to suit you best.
- The standard adjuster setting for an average-build rider of 68 kg (150 lb) with no passenger and no accessories is the **3 turns backward** from the fully tightened position.
- ★ If the damping feels too soft or too stiff, adjust it.

Rebound Damping Force Adjustment

Adjuster Position	Damping Force	Setting	Load	Road	Speed
5	Weak	Soft	Light	Good	Low
↑	↑	↑	↑	↑	↑
↓	↓	↓	↓	↓	↓
0	Strong	Hard	Heavy	Bad	High

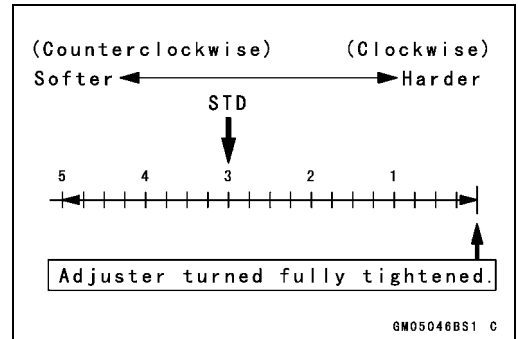
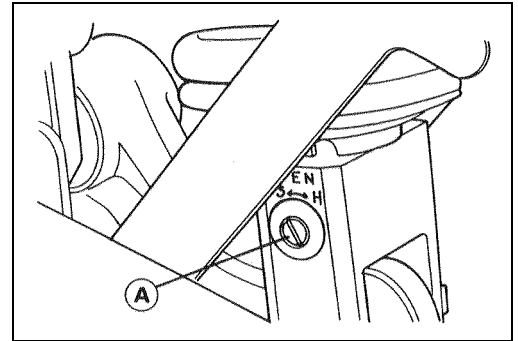

Compression Damping Force Adjustment

- To adjust the compression damping force, turn the compression damping adjuster [A] on the gas reservoir to suit you best.
- The standard adjuster setting for the average-build rider of 68 kg (150 lb) with no passenger and no accessories is the **2 1/4 turns backward** from the fully tightened position.
- The damping force can be left soft for average riding. But it should be adjusted harder for high speed riding or riding with a passenger. If the damping feels too soft or too stiff, adjust it in accordance with the following table.

Compression Damping Force Adjustment

Adjuster Position	Damping Force	Setting	Load	Road	Speed
5	Weak	Soft	Light	Good	Low
↑	↑	↑	↑	↑	↑
↓	↓	↓	↓	↓	↓
0	Strong	Hard	Heavy	Bad	High

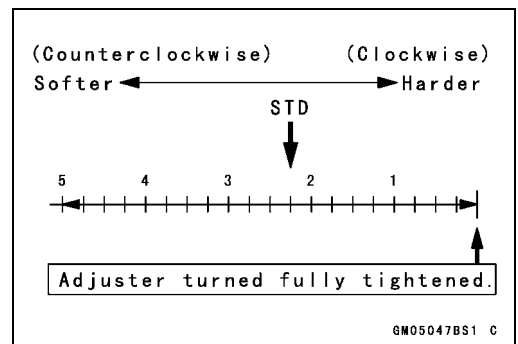
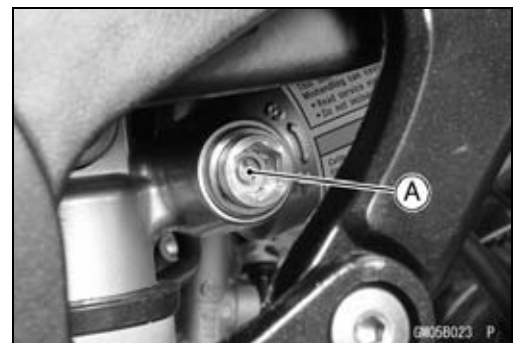

13-12 SUSPENSION

Rear Shock Absorber

Spring Preload Adjustment

- Remove the rear shock absorber from the frame to measure the spring length (see Rear Shock Absorber Removal).
- Loosen the locknut [B] and turn out the adjusting nut [A] to free the spring.

Special Tool - Hook Wrench: 57001-1522

- Measure the spring free length [C].

Spring Free Length

Standard: 191.5 mm (7.54 in.)

Spring Preload Setting

Standard: Spring length 177 mm (6.97 in.)

Usable Range: Spring length 191.5 (7.54 in.) to 170 mm (6.69 in.) (weaker to stronger)

- The standard adjusting nut setting for an average-build rider of 68 kg (150 lb) with no passenger and no accessories is 177 mm (6.97 in.) spring length.

- To adjust the spring preload, turn in the adjusting nut to the desired position and tighten the locknut using by hook wrenches [A] with the rear shock absorber attached the frame.

- Remove the chain cover (see Final Drive chapter) and left foot guard for turning the hook wrench easily.

- ★ If the spring action feels too soft or too stiff, adjust it.

Special Tool - Hook Wrench: 57001-1522

Spring Adjustment

Adjuster Position	Damping Force	Setting	Load	Road	Speed
191.5 mm (7.54 in.)	Weak	Soft	Light	Good	Low
↑	↑	↑	↑	↑	↑
↓	↓	↓	↓	↓	↓
170 mm (6.69 in.)	Strong	Hard	Heavy	Bad	High

Rear Shock Absorber Removal

- Remove the lower fairings (see Frame chapter).
- Raise the rear wheel off the ground with the jack.

Special Tool - Jack: 57001-1238

- Remove:
 - Upper Tie-Rod Nut and Bolt [A]
 - Lower Shock Absorber Nut and Bolt [B]

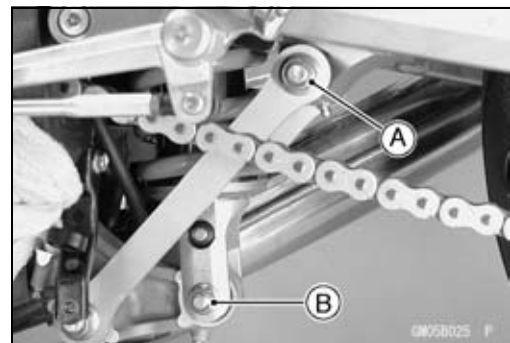
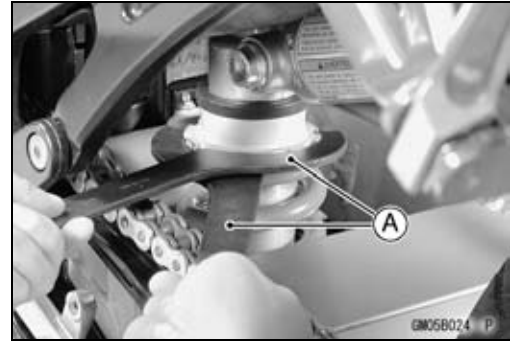
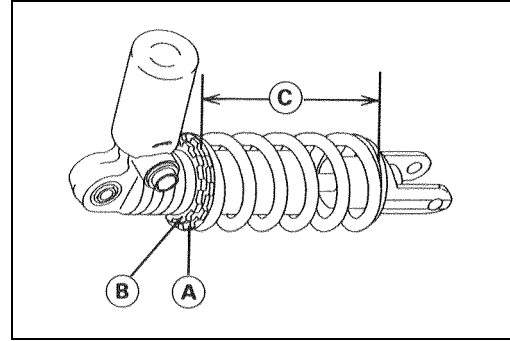

Rear Shock Absorber

- Remove:
 - Upper Shock Absorber Nut
 - Upper Shock Absorber Bolt [A]
- Lift up [B] the rear fender front with a suitable bar or your hand to the arrow direction, and then pull out the absorber Bolt.
- Remove the shock absorber from under.

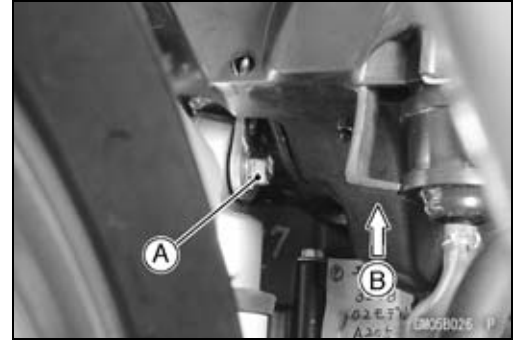

Rear Shock Absorber Installation

- Pack the rocker arm needle bearings with grease.
- Tighten the following nuts:
 - Torque - Rear Shock Absorber Nuts: 34 N·m (3.5 kgf·m, 25 ft·lb)
 - Tie-Rod Nuts: 59 N·m (6.0 kgf·m, 44 ft·lb)

Rear Shock Absorber Scrapping

⚠ WARNING

Since the reservoir tank of the rear shock absorber contains nitrogen gas, do not incinerate the reservoir tank without first releasing the gas or it may explode.

- Remove the shock absorber (see Rear Shock Absorber Removal).
- Take off the cap [A] of reserve tank and release the nitrogen gas from the valve of the gas reservoir completely.

⚠ WARNING

Since the high pressure gas is dangerous, do not point the valve toward your face or body.

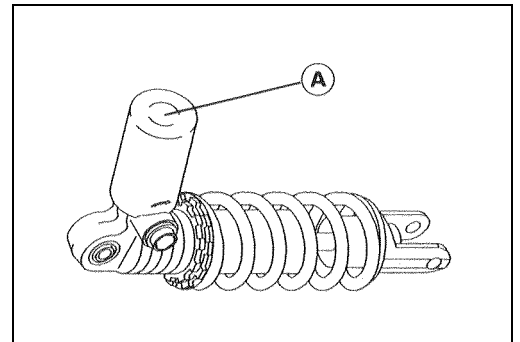

13-14 SUSPENSION

Swingarm

Swingarm Removal

- Remove the lower fairings (see Frame chapter).
- Remove the side stand mounting bracket (see Frame chapter).
- Raise the rear wheel of the ground with the jack.

Special Tool - Jack: 57001-1238

- Remove:
 - Rear Wheel (see Wheels/Tires chapter)
 - Chain Cover (see Final Drive chapter)
 - Rear Shock Absorber (see this chapter)
 - Brake Hose Clamps [A]

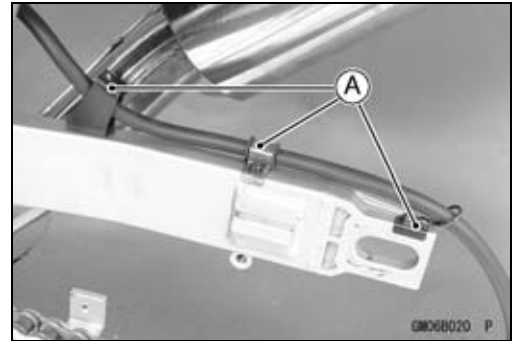

- Unscrew the swingarm pivot shaft locknut [A].

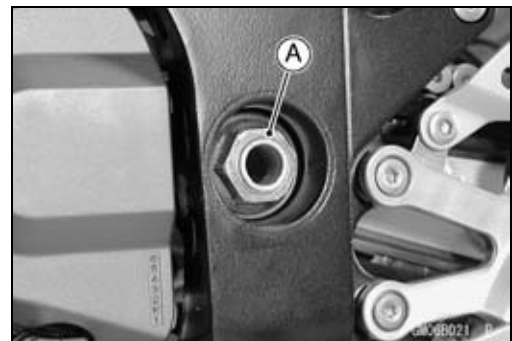

- Unscrew the swingarm pivot shaft nut [A].
Special Tool - Socket Wrench [B]: 57001-1370

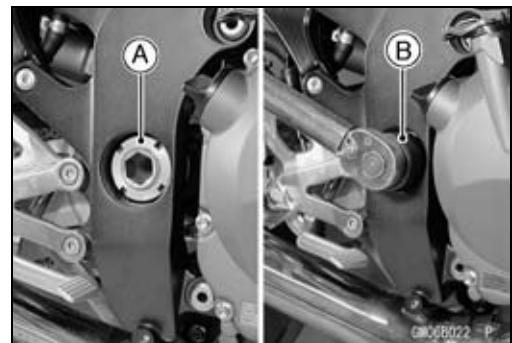

- Unscrew the swingarm pivot shaft [A] with the Allen wrench.
- Pull off the pivot shaft and remove the swingarm.

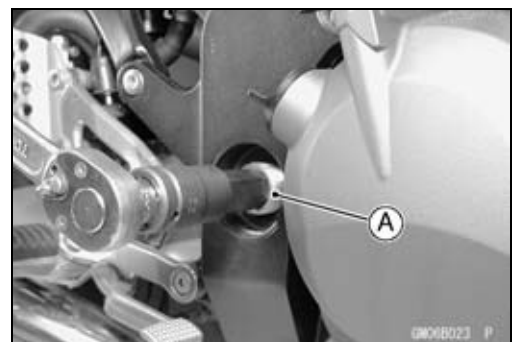

Swingarm

Swingarm Installation

- Apply plenty of grease to the ball bearing, needle bearings and grease seals.
- Install the collars [A].

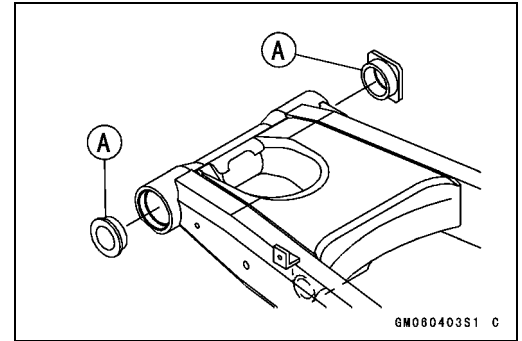

○ Place the right collar [A] on the stopper [B] inside the frame [C].

- Insert the pivot shaft into the frame from the right side.
- Tighten the pivot shaft so that the clearance between the collar and the frame come to zero mm [D].
- Tighten the pivot nut.

Torque - Swingarm Pivot Nut: 125 N·m (13 kgf·m, 92 ft·lb)

- Tighten the pivot locknut.

Torque - Swingarm Pivot Shaft Locknut: 98 N·m (10 kgf·m, 72 ft·lb)

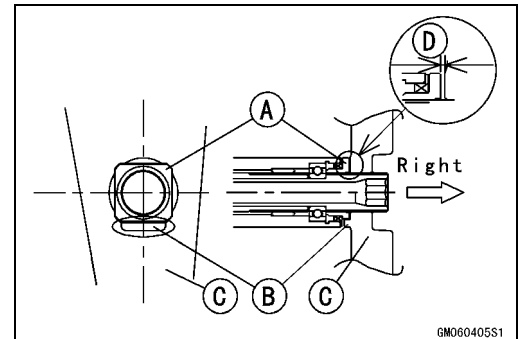

- Install the side stand bracket.

Torque - Side Stand Mounting Bracket Bolts: 49 N·m (5.0 kgf·m, 36 ft·lb)

- Install the removed parts (see appropriate chapters).

Swingarm Bearing Removal

- Remove:
 - Swingarm
 - Collars [A]
 - Grease Seals [B]
 - Sleeve [C]
 - Circlip (right side) [D]

Special Tool - Inside Circlip Pliers: 57001-143

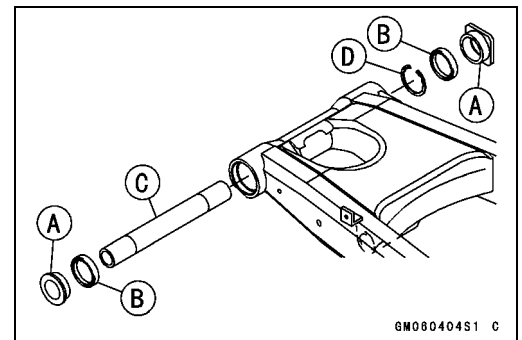

- Remove the ball bearing and needle bearings using the oil seal & bearing remover [A].

Special Tool - Oil Seal & Bearing Remover: 57001-1058

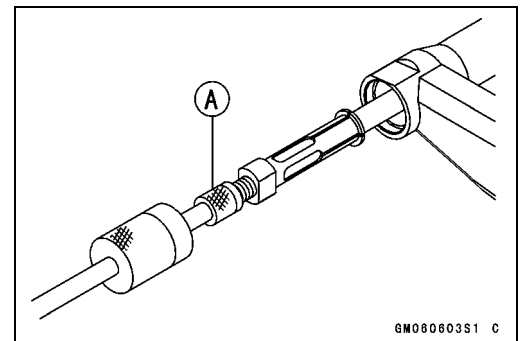

13-16 SUSPENSION

Swingarm

Swingarm Bearing Installation

- Apply plenty of grease to the ball bearing and needle bearings.
- Install the needle bearings so that the manufacturer's marks face out.
- Install the ball bearing so that the manufacturer's marks face out.

Special Tool - Bearing Driver Set: 57001-1129 [A]

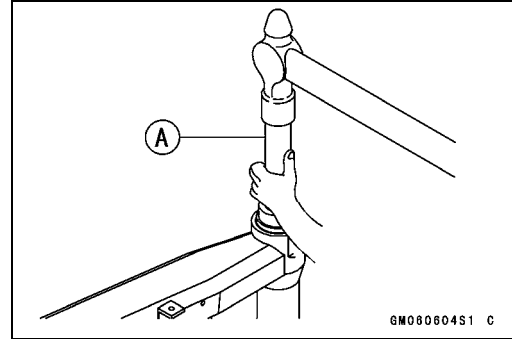

Swingarm Bearing, Sleeve Inspection

CAUTION

Do not remove the bearings for inspection. Removal may damage them.

- Inspect the needle bearings [A] and ball bearing [B] installed in the swingarm.
- The rollers and ball in a bearing normally wear very little, and wear is difficult to measure. Instead of measuring, visually inspect the bearing for abrasion, discoloration, or other damage.
- ★ If the needle bearing, ball bearing, and sleeve show any signs of abnormal wear, discoloration, or damage, replace them as a set.

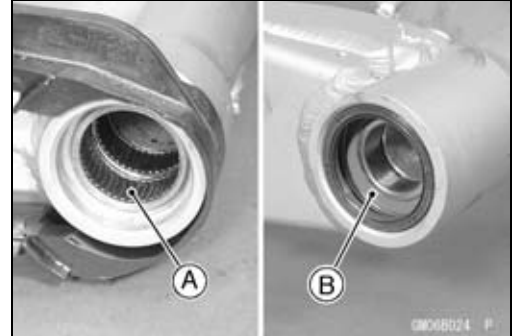

Swingarm Pivot Lubrication

- Refer to the Swingarm Pivot Lubrication in the Periodic Maintenance chapter.

Chain Slider Inspection

- Visually inspect the chain slider [A].
- ★ Replace the chain slider if it shows any signs of abnormal wear or damage.

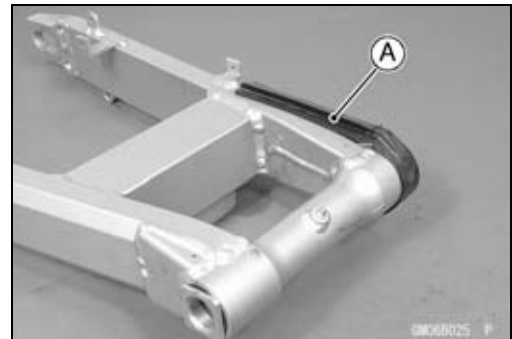

Tie-Rod, Rocker Arm

Tie-Rod Removal

- Remove the lower fairings (see Frame chapter).
- Remove the side stand mounting bracket (see Frame chapter).
- Raise the rear wheel off the ground with the jack.

Special Tool - Jack: 57001-1238

- Remove:
 - Upper Tie-Rod Bolts and Nut [A]
 - Lower Rear Shock Absorber Bolt and Nut [B]
- Remove:
 - Lower Tie-Rod Nut [A]
 - Rocker Arm nut [B]
- Remove the muffler body mounting bolt (see Engine Top End chapter).
- Remove the rocker arm bolt pushing down the muffler.
- Pull out the lower tie-rod bolt from the rocker arm.

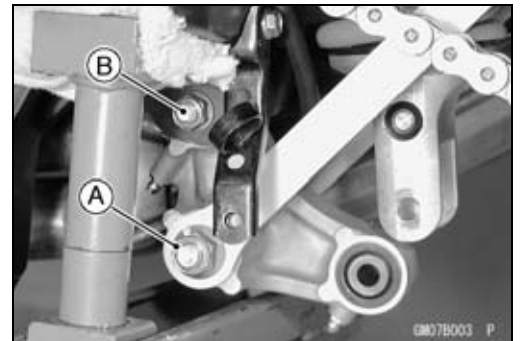
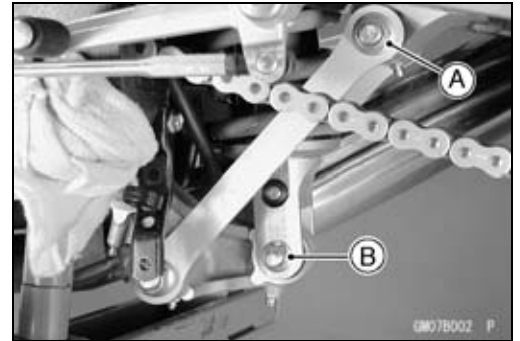

Tie-Rod Installation

- Apply grease to the inside of the needle bearings and oil seals.
- Install the tie-rods so that the marked side faces outer side.
- Tighten each bolts.

Torque - Rocker Arm Nut: 34 N·m (3.5 kgf·m, 25 ft·lb)

Tie-Rod Nuts: 59 N·m (6.0 kgf·m, 44 ft·lb)

Lower Rear Shock Absorber Nut: 34 N·m (3.5 kgf·m, 25 ft·lb)

Rocker Arm Removal

- Remove the lower fairings (see Frame chapter).
- Remove the side stand mounting bracket (see Frame chapter).
- Raise the rear wheel off the ground with the jack.

Special Tool - Jack: 57001-1238

- Remove:
 - Upper Tie-Rod Bolt and Nut
 - Lower Rear Shock Absorber Bolt and Nut
 - Muffler Body Mounting Bolt
 - Lower Tie-Rod Nut [A]
 - Rocker Arm Bolt and Nut [B]
 - Rocker Arm [C]
- Remove the rocker arm bolt pushing down the muffler.

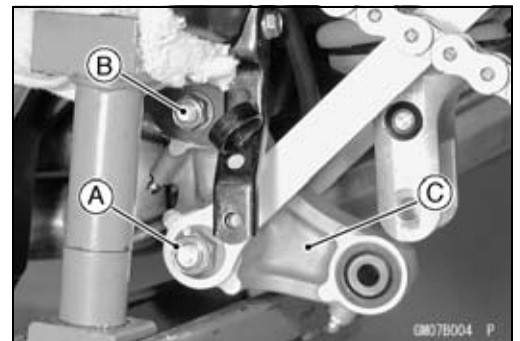

Rocker Arm Installation

- Apply grease to the inside of the needle bearings and oil seal lips, and add grease to the grease nipple.
- Tighten the rocker arm nut, tie-rod nut and shock absorber lower nut.

Torque - Rocker Arm Nut: 34 N·m (3.5 kgf·m, 25 ft·lb)

Tie-Rod Nuts: 59 N·m (6.0 kgf·m, 44 ft·lb)

Lower Rear Shock Absorber Nut: 34 N·m (3.5 kgf·m, 25 ft·lb)

13-18 SUSPENSION

Tie-Rod, Rocker Arm

Needle Bearing Inspection

★If there is any doubt as to the condition of either needle bearing, replace the bearing and sleeve as a set, and/or add grease to the grease nipple.

Tie-Rod, Rocker Arm Sleeve Inspection

★If there is visible damage, replace the sleeve and needle bearing as a set.

Uni-track Linkage Lubrication

● Refer to the Uni-track Linkage Lubricate in the Periodic Maintenance chapter.

Steering

Table of Contents

- Exploded View..... 14-2
- Specifications 14-3
- Steering 14-4
 - Steering Inspection 14-4
 - Steering Adjustment..... 14-4
- Steering Stem..... 14-5
 - Stem, Stem Bearing Removal..... 14-5
 - Stem, Stem Bearing Installation..... 14-6
 - Steering Bearing Lubrication and Inspection 14-9
 - Steering Stem Warp..... 14-9
- Handlebar 14-10
 - Handlebar Removal 14-10
 - Handlebar Installation 14-10

Specifications

Special Tools - Head Pipe Outer Race Press Shaft: 57001-1075
Steering Stem Nut Wrench: 57001-1100
Head Pipe Outer Race Remover: 57001-1107
Jack: 57001-1238
Steering Stem Bearing Driver: 57001-1344
Steering Stem Bearing Driver Adapter: 57001-1345
Head Pipe Outer Race Driver ϕ 55: 57001-1446
Head Pipe Outer Race Driver ϕ 47: 57001-1447

14-4 STEERING

Steering

Steering Inspection

- Refer to the Steering Inspection in the Periodic Maintenance chapter.

Steering Adjustment

- Refer to the Steering Inspection in the Periodic Maintenance chapter.

Steering Stem

Stem, Stem Bearing Removal

- Remove:
 - Brake Hose Joint Cover Screws [A]
 - Front Wheel (see Wheels/Tires chapter)
 - Front Fork (see Suspension chapter)
 - Steering Stem Head Nut and Washer
 - Steering Stem Head with Handlebars



- Remove the brake hose joint bolt [A].

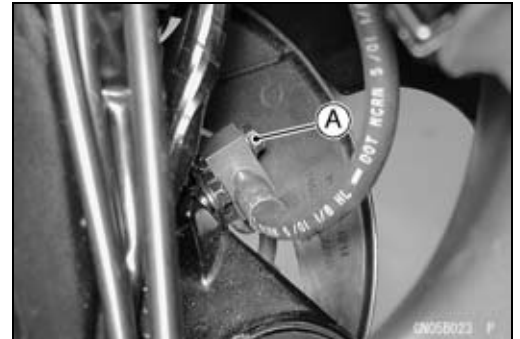

ZX1200-B1/B2

- Take off the lock washer [A] to remove the steering stem nut [B] and pull the steering stem [C] with the bearing and oil seal downward.

Special Tool - Steering Stem Nut Wrench: 57001-1100

- Remove the oil seal, bearing inner race and ball bearing assy from the upper head pipe.

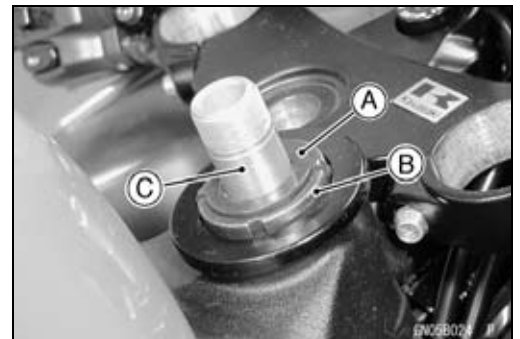

ZX1200-B3

- Bend the claw washer tabs [A].
- Remove the steering stem locknut [B].

Special Tool - Steering Stem Nut Wrench: 57001-1100

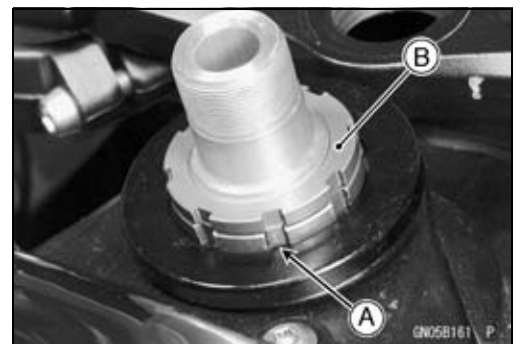

- Remove the claw washer [A].



14-6 STEERING

Steering Stem

- Pushing up the stem base, and remove the steering stem nut [A] with oil seal.

Special Tool - Steering Stem Nut Wrench [B]: 57001-1100

- Remove:
Steering Stem [C]
Upper Ball Bearing Inner Race

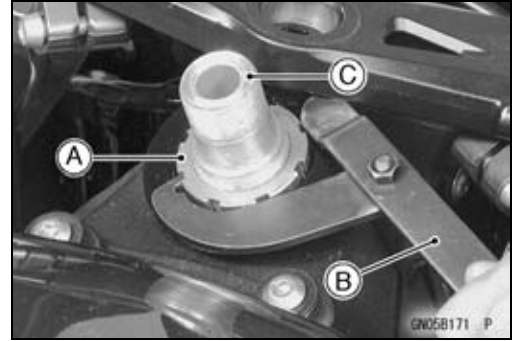

- Drive out the bearing outer races [B] from the head pipe.

Special Tool - Head Pipe Outer Race Remover: 57001-1107 [A]

NOTE

○ If either steering stem bearing is damaged, it is recommended that both the upper and lower bearings (including outer races) should be replaced with new ones.

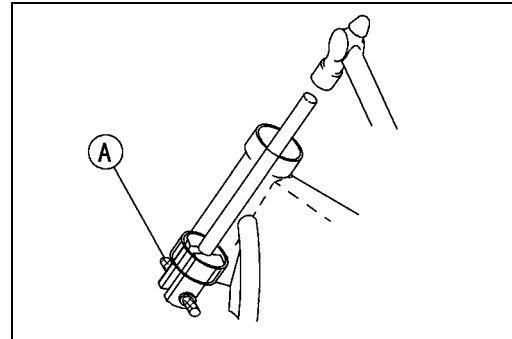

- Remove the lower inner race [A] (with its grease seal [B]) which is pressed onto the steering stem with a suitable commercially available bearing puller or chisel [C].

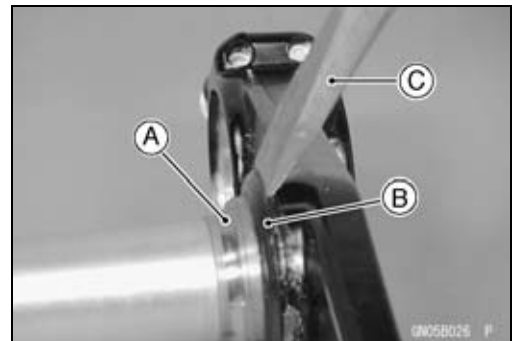

Stem, Stem Bearing Installation

- Replace the outer races, inner races and ball bearings with new ones.
- Apply grease to the outer races, and drive them into the head pipe at the same time.

Special Tools - Head Pipe Outer Race Press Shaft: 57001-1075 [A]

Head Pipe Outer Race Driver ϕ 55: 57001-1446

Head Pipe Outer Race Driver ϕ 47: 57001-1447 [B]

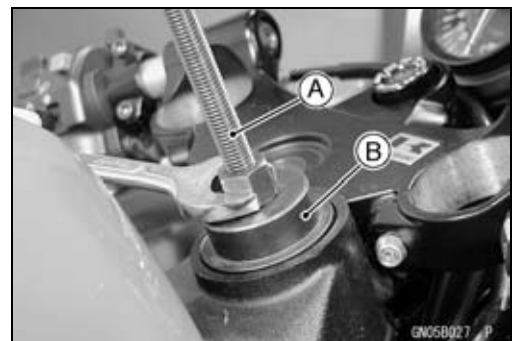

Steering Stem

- Install the oil seal [A] on the steering stem, and drive the lower ball bearing inner race [B] applied the grease on to the stem.

Special Tools - Steering Stem Bearing Driver: 57001-1344 [C]

Steering Stem Bearing Driver Adapter: 57001-1345 [D]

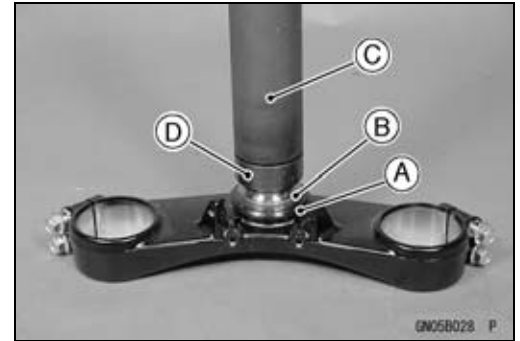

- Install the lower ball bearing [A] onto the stem.
- Apply grease to the lower and upper ball bearings [B] and outer races.

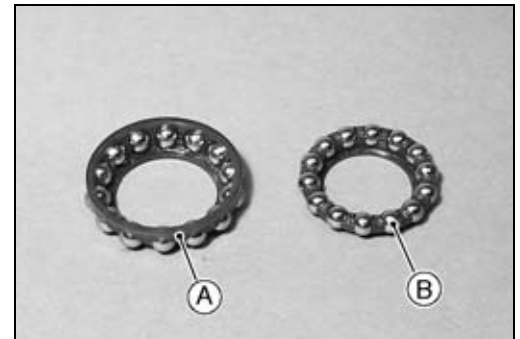

- Install the stem [A] through the head pipe and install the ball bearing [B] and inner race [C] on it.
- Install the oil seal [D] and steering stem nut.
 - Stem Nut (ZX1200-B1/B2) [E]
 - Stem Nut (ZX1200-B3) [F]

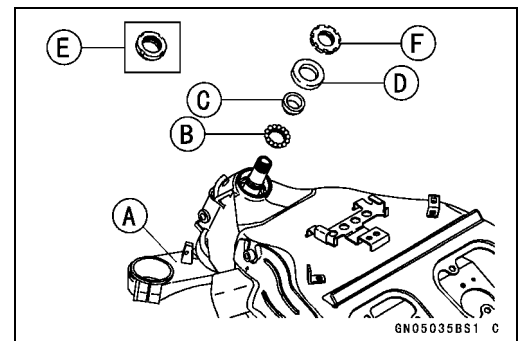

- Settle the inner races in place as follows:
 - Tighten the steering stem nut with 20 N·m (2.0 kgf·m, 15 ft·lb) of torque first, and loosen it a fraction of a turn until it turns lightly. Afterward tighten it again with specified torque using the stem nut wrench [A].
 - Check that there is no play and the steering stem turns smoothly without rattles. If not, the bearings on the inner races may be damaged.

Special Tool - Steering Stem Nut Wrench: 57001-1100

Torque - Steering Stem Nut: 20 N·m (2.0 kgf·m, 15 ft·lb)

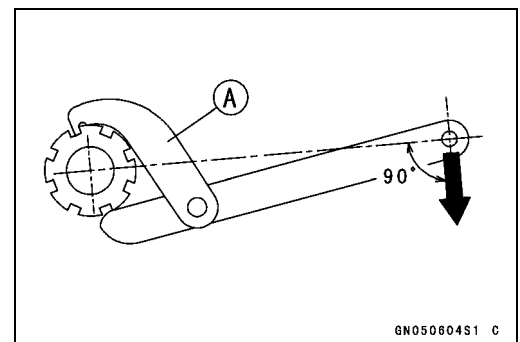

14-8 STEERING

Steering Stem

ZX1200-B1/B2

- Install the lock washer.
- Install the stem head.
- Install the washer, and tighten the stem head nut with specified torque.
- Install the front fork (see Suspension chapter).

NOTE

- Tighten the fork upper clamp bolts first, next the stem head nut, last the fork lower clamp bolts.
- Tighten the two clamp bolts alternately two times to ensure even tightening torque.

Torque - Steering Stem Head Nut: 54 N·m (5.5 kgf·m, 40 ft·lb)

Front Fork Clamp Bolts (Upper): 20 N·m (2.0 kgf·m, 15 ft·lb)

Front Fork Clamp Bolts (Lower): 20 N·m (2.0 kgf·m, 15 ft·lb)

⚠ WARNING

Do not impede the handlebar turning by routing the cables, harnesses and hoses improperly (see General Information chapter).

- Install the removed parts (see appropriate chapters).

ZX1200-B3

- Install the claw washer [A] so that its bent side [B] faces upward, and engage the bent claws with the grooves of stem locknut [C].
- Hand tighten the stem locknut until it touches the claw washer.
- Tighten the stem locknut clockwise until the claws are aligned with the grooves of stem nut [D], and bend the 2 claws downward [E].
- Install the stem head.
- Install the washer, and tighten the stem head nut with specified torque.
- Install the front fork (see Suspension chapter).

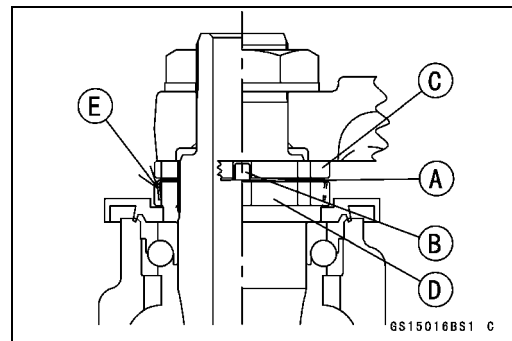

Steering Stem

NOTE

- Tighten the fork upper clamp bolts first, next the stem head nut, last the fork lower clamp bolts.
- Tighten the two clamp bolts alternately two times to ensure even tightening torque.

Torque - Steering Stem Head Nut: 78 N·m (8.0 kgf·m, 57 ft·lb)

Front Fork Clamp Bolts (Upper):

20 N·m (2.0 kgf·m, 15 ft·lb)

Front Fork Clamp Bolts (Lower):

20 N·m (2.0 kgf·m, 15 ft·lb)

⚠ WARNING

Do not impede the handlebar turning by routing the cables, harnesses and hoses improperly (see General Information chapter).

- Install the removed parts (see appropriate chapters).

Steering Bearing Lubrication and Inspection

- Refer to the Steering Stem Bearing Lubrication in the Periodic Maintenance chapter.

Steering Stem Warp

- Whenever the steering stem is removed, or if the steering cannot be adjusted for smooth action, check the steering stem for straightness [A].
- ★ If the steering stem shaft is bent, replace the steering stem.



14-10 STEERING

Handlebar

Handlebar Removal

- Remove:
 - Clutch Lever Assembly [A]
 - Left Handlebar Switch Housing [B]
 - Front Brake Master Cylinder [C]
 - Right Handlebar Switch Housing [D]
 - Throttle Case [E]

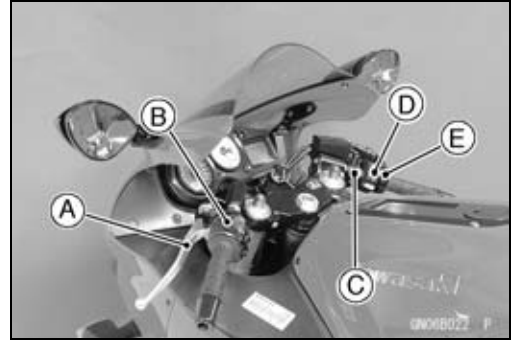

- Remove:
 - Weight Bolts [A]
 - Handlebar Weight [B]
 - Fitting [C]
 - Clip [D]

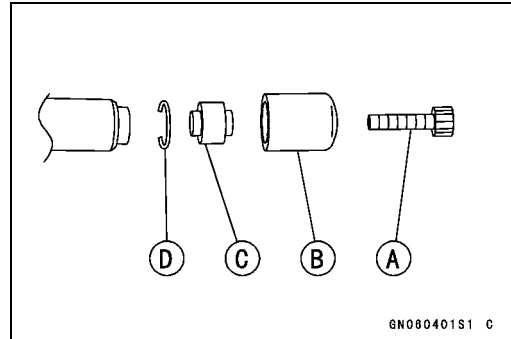

- Remove:
 - Throttle Grip
 - Handlebar Bolts [A]
- Pull out the handlebars [B].

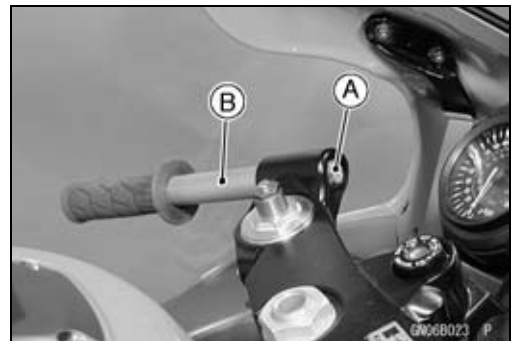

Handlebar Installation

- Apply a non-permanent locking agent to the threads of the handlebar bolts and weight bolts.

Torque - Handlebar Bolts: 34 N·m (3.5 kgf·m, 25 ft·lb)

- Install the brake master cylinder (see Brakes chapter).
- Install the clutch lever [A] so that the mating surface [B] of the left handlebar switch housing is aligned with the mating surface [C] of the clutch lever clamp.

Torque - Clutch Lever Clamp Bolts: 7.8 N·m (0.80 kgf·m, 69 in·lb)

Handlebar Switch Housing Screws: 3.5 N·m (0.36 kgf·m, 31 in·lb)

- Install the removed parts (see appropriate chapters).

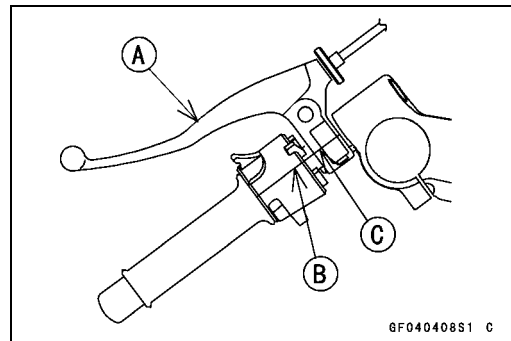

Frame

Table of Contents

Exploded View	15-2	Lower Inner Covers (Left and Right) Removal	15-10
Seats	15-5	Lower Inner Covers (Left and Right) Installation	15-11
Rear Seat Removal.....	15-5	Upper Fairing Removal	15-11
Rear Seat Installation.....	15-5	Upper Fairing Disassembly.....	15-12
Rear Seat Cover Removal	15-5	Upper Fairing Assembly.....	15-13
Rear Seat Cover Installation	15-6	Hot Wind Cover Installation	15-14
Front Seat Removal	15-6	Fenders	15-15
Front Seat Installation	15-6	Front Fender Removal	15-15
Seat Cover.....	15-7	Front Fender Installation	15-15
Seat Cover Removal.....	15-7	Rear Fender Rear Removal.....	15-15
Seat Cover Installation.....	15-7	Rear Fender Rear Installation.....	15-15
Fairings.....	15-8	Rear Fender Front Removal	15-16
Lower Fairings (Left and Right) Removal	15-8	Rear Fender Front Installation	15-16
Lower Fairings (Left and Right) Installation	15-8	Rear Frame	15-17
Lower Inner Fairing Removal.....	15-9	Rear Frame Removal.....	15-17
Lower Inner Fairing Installation....	15-9	Rear Frame Installation.....	15-17
Upper Inner Fairings (Left and Right) Removal	15-9	Frame Inspection	15-17
Upper Inner Fairings (Left and Right) Installation	15-9	Storage Box.....	15-18
Wind Shield Removal.....	15-10	Storage Box Removal	15-18
Wind Shield Installation.....	15-10	Storage Box Installation	15-18
Upper Inner Covers (Left and Right) Removal	15-10	Side Stand.....	15-19
Upper Inner Covers (Left and Right) Installation	15-10	Side Stand Removal	15-19
		Side Stand Installation	15-19

Exploded View

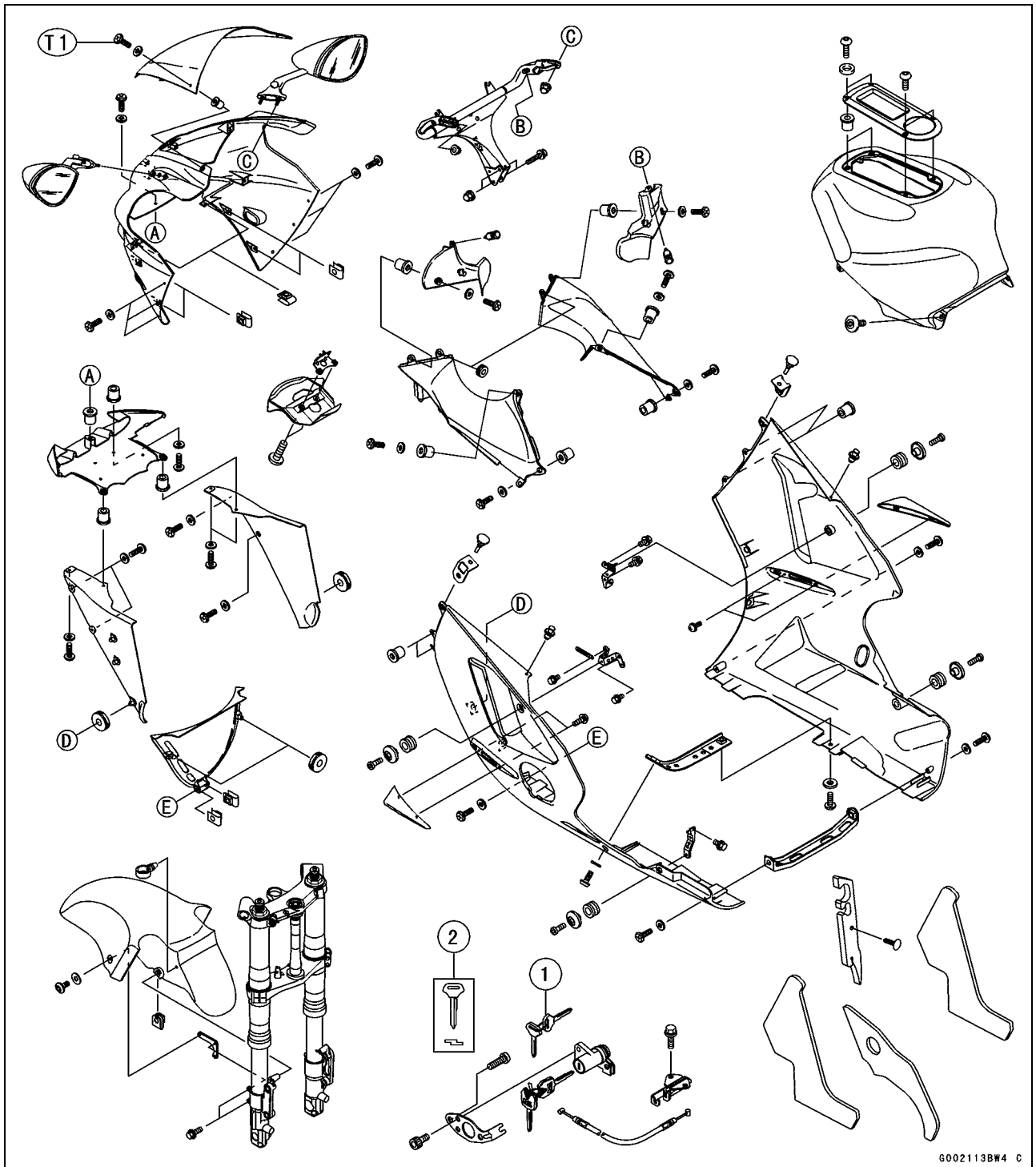

G002113BW4 C

- 1. Key (ZX1200-B1/B2)
- 2. Key Option (ZX1200-B1/B2)
- T1: 0.40 N·m (0.040 kgf·m, 3.5 in·lb)

15-4 FRAME

Exploded View

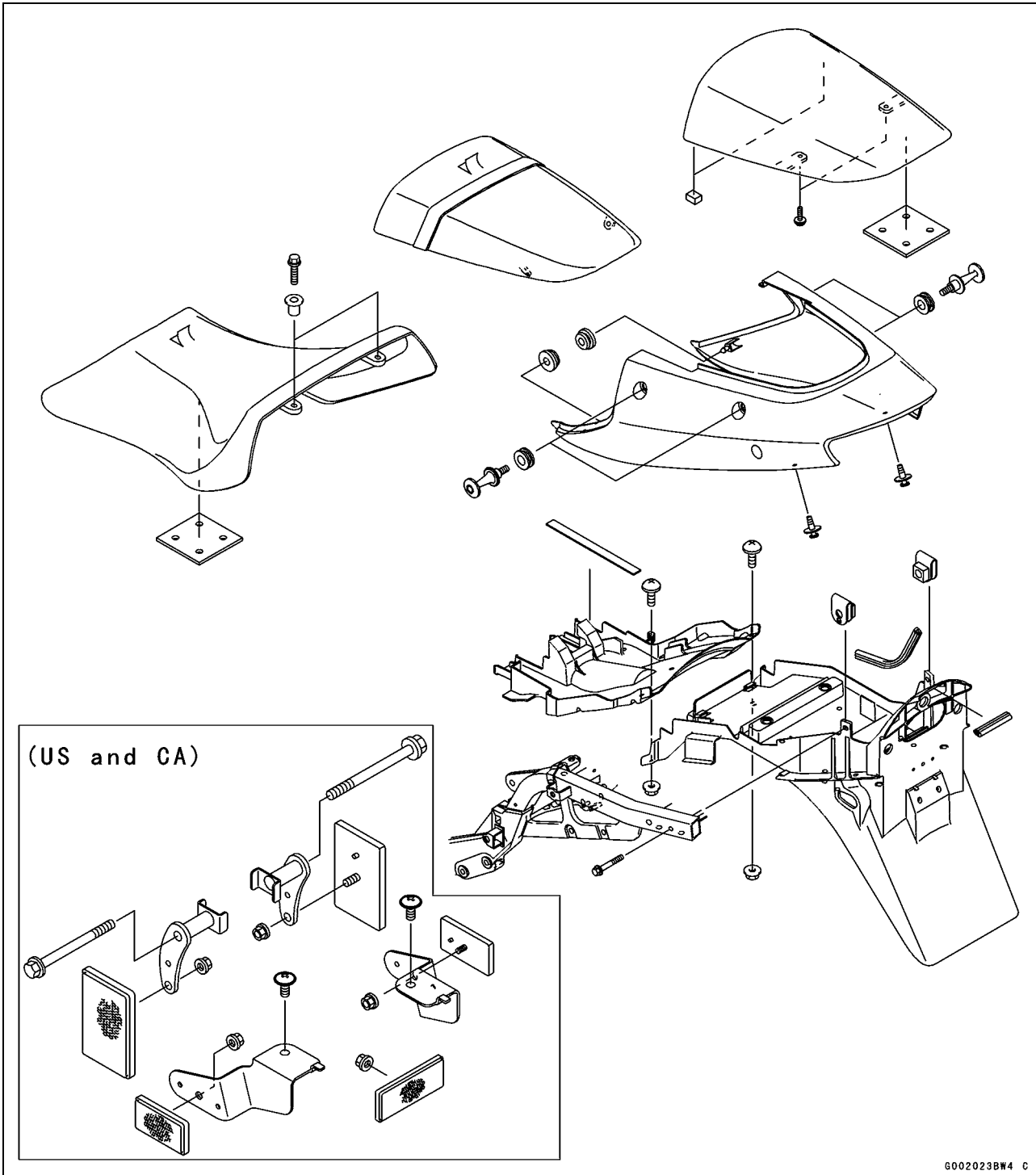

6002023BW4 C

CA: Canadian Model
US: U.S.A. Model

Seats

Rear Seat Removal

- Insert the ignition switch key into the seat lock [A], turning the key clockwise, pulling up on the rear of the seat with seat cover [B], and pulling the seat backward.

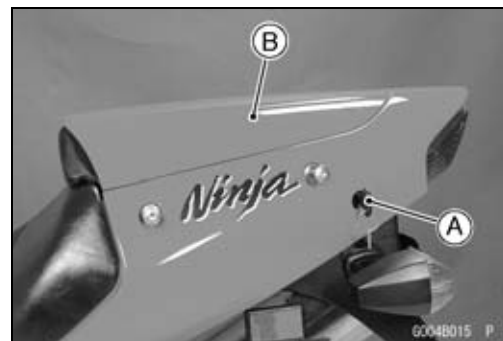

Rear Seat Installation

- Slip the rear seat hooks [A] into the hollow-cubic brackets [B] on the frame.
- Insert the seat projection [C] into the latch hole [D].
- Push down the rear part of the seat until the lock clicks.

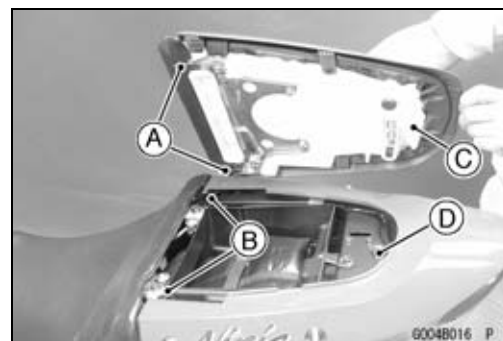

Rear Seat Cover Removal

- Remove:
Rear Seat
Screws [A]

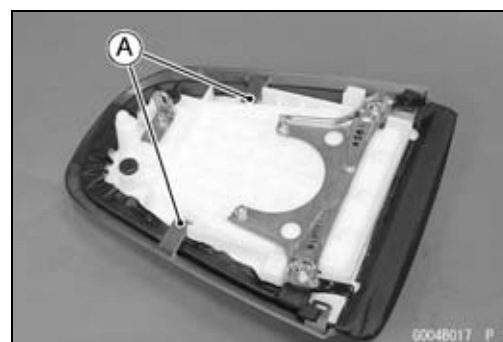

- Remove the front bracket portions [A] from the projection [B] of the seat.

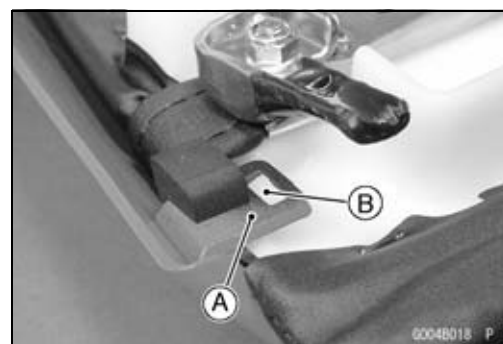

- Clear the bracket portions [A] from the seat band [B].
- Pull the seat cover [C] out.

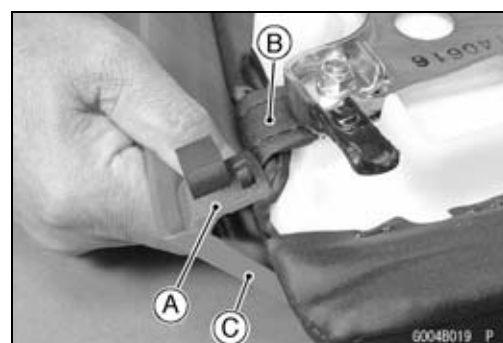

15-6 FRAME

Seats

Rear Seat Cover Installation

- Fit the two projections [A] of the rear seat front portion into the slots [B] in the front bracket of the seat cover.
- Tighten the two screws.

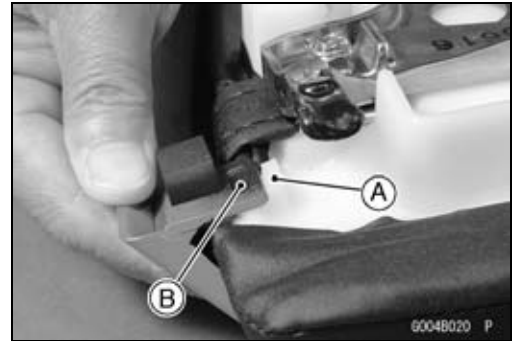

Front Seat Removal

- Remove:
 - Rear Seat (see Rear Seat Removal)
 - Mounting Bolts [A]
- Remove the front seat [B] by pulling it up on the rear and to the rear.

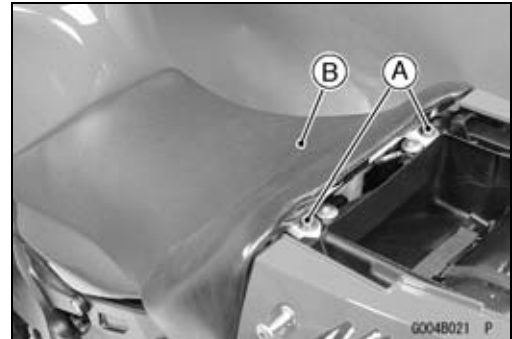

Front Seat Installation

- Slip in the front seat holes [A] to the projections [B] on the fuel tank.
- Tighten the bolts with collar.

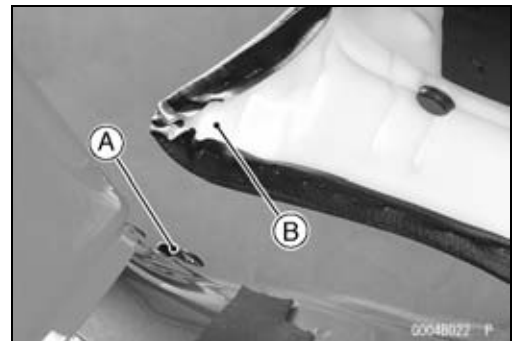

Seat Cover

Seat Cover Removal

- Remove:
 - Unscrew and pull out the rivet screws.
 - Seats
 - Rivet Screws [A] (Left and Right)
 - Hook Bolts [B]
 - Pull the front portions [C] of the seat cover outside, and then remove the seat cover backward.

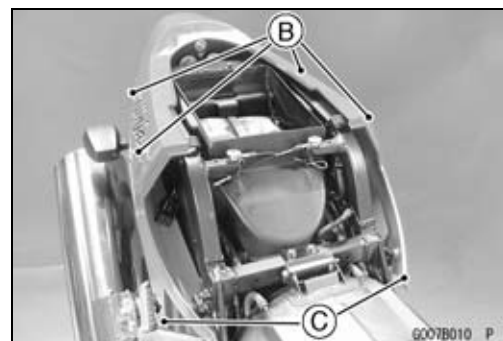

- Pull out the seat lock wire [C] from the bracket [B] to remove the seat lock wire end [A].

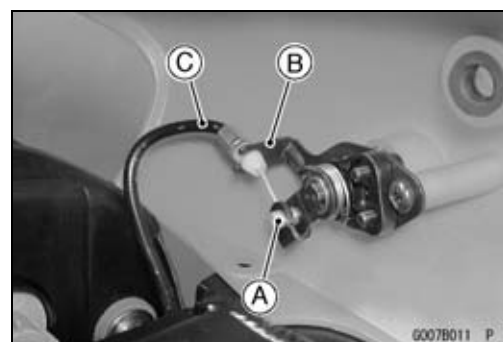

- Remove:
 - Screws [A]
 - Seat Lock [B]

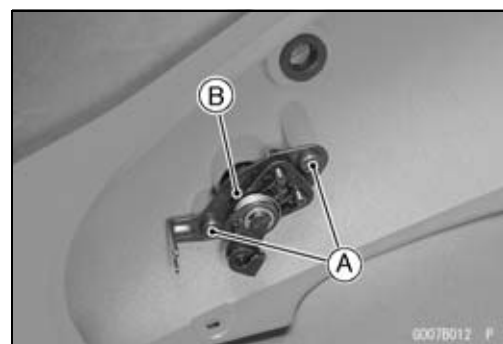

Seat Cover Installation

- Installation is reverse of removal.
- Put the projections [A] into the grommets [B] on the frame brackets.

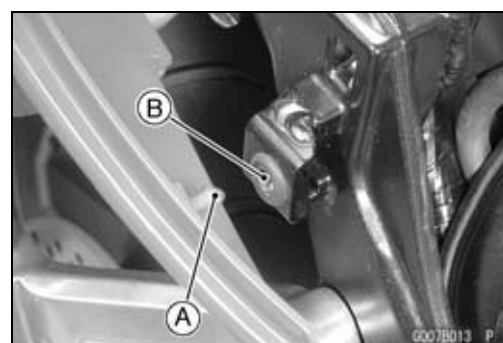

15-8 FRAME

Fairings

Lower Fairings (Left and Right) Removal

- Remove:
 - Screws [A]
 - Rivet Screws [B]
 - Allen Bolts [C]

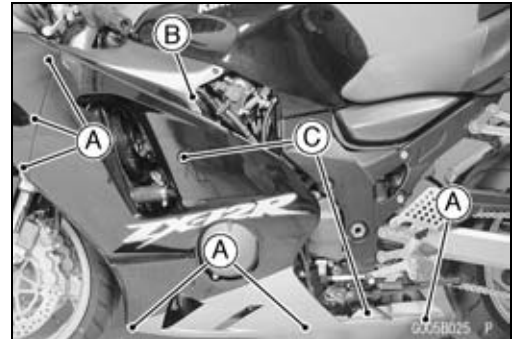
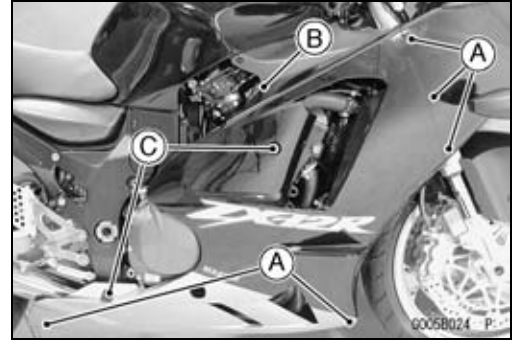

- Remove the lower fairings from the upper and lower inner fairings.

○ Pull the lower inner fairing [A] forward to clear its projections [B] from the grommets [C] on the lower fairings [D].

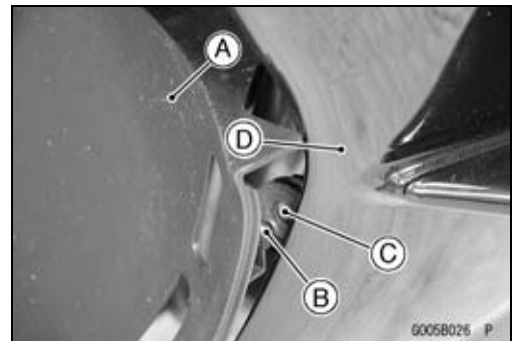

○ Pull out the lower fairings [A] to clear the its grommets [B] from the projections [C] of the upper inner fairings [D].

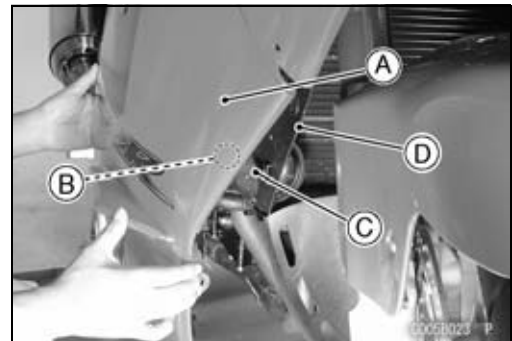

Lower Fairings (Left and Right) Installation

- Be sure to place in the hot wind cover (see Hot Wind Cover Installation).
- Fit the projection [A] on the upper inner fairings [B] into the grommets [C] on the lower fairings [D].
- Insert the projection of the lower inner fairing into the grommets on the lower fairings.

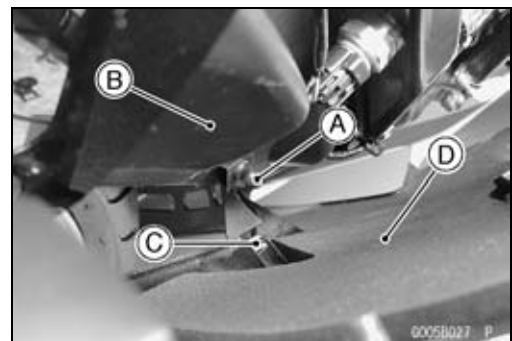

- First tighten the Allen bolts temporarily, and tighten all screws lightly.
- Tighten the Allen bolts and screws.

Fairings

Lower Inner Fairing Removal

- Remove:
 - Screws [A]

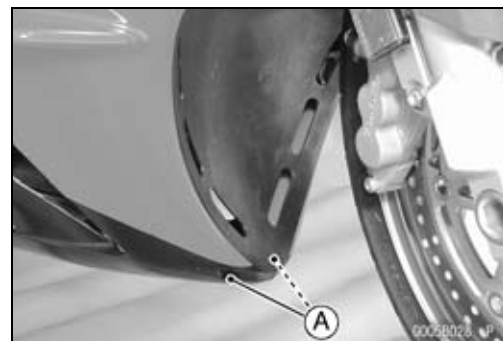

- Remove:
 - Lower Inner Fairing [A]
- Pull the upper projection of the lower inner fairing [A] forward to remove the its projections [B] from the grommets [C] on the lower fairings [D].

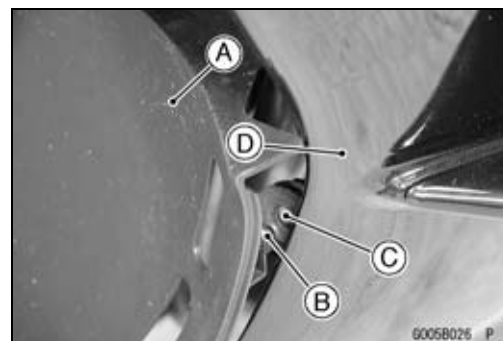

Lower Inner Fairing Installation

- Lower inner fairings installation is the reversed of removal.
- Push the upper portion of the lower inner fairing backward to insert the its projection into the grommets on the lower fairings.

Upper Inner Fairings (Left and Right) Removal

- Remove:
 - Screw [A]
 - Lower Inner Fairing (see Lower Inner Fairing Removal)
 - Horn Mounting Bolts

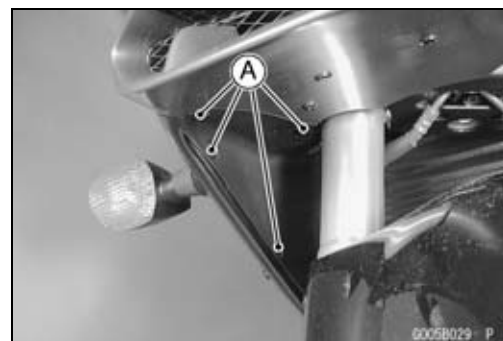

- Remove the upper inner fairings [A] from the lower fairings and ducts.
- Pull out the upper inner fairings inward to clear its projections [B] from the grommets [C] on the lower fairings and ducts.

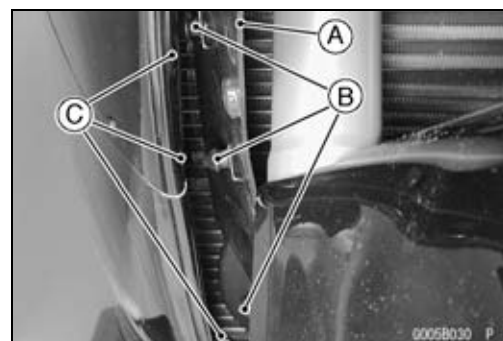

Upper Inner Fairings (Left and Right) Installation

- Fit the projections into the grommets on the lower fairings and ducts.
- Install the lower inner fairing and horn mounting bolts.

15-10 FRAME

Fairings

Wind Shield Removal

- Remove:
 - Pull off the wind shield upward after removing the screws.
 - Screws [A]
 - Wind Shield [B]

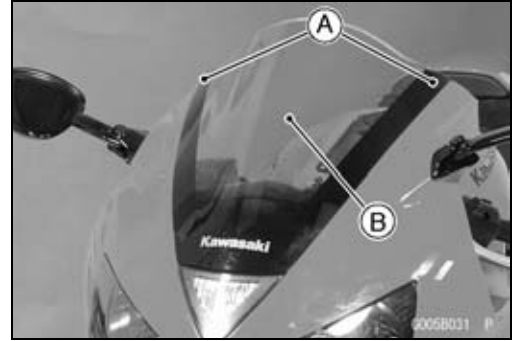

Wind Shield Installation

- Insert the tabs [A] of the shield in to the holes [B] of the upper fairing.
- Tighten the screws.
 - Torque - Wind Shield Mounting Screws: 0.40 N·m (0.040 kgf·m, 3.5 in·lb)**

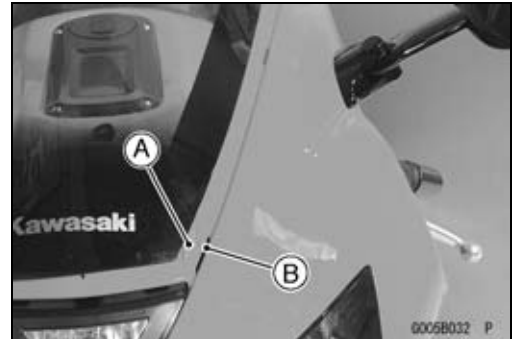

Upper Inner Covers (Left and Right) Removal

- Remove:
 - Screws [A]
 - Rivet Screws [B]

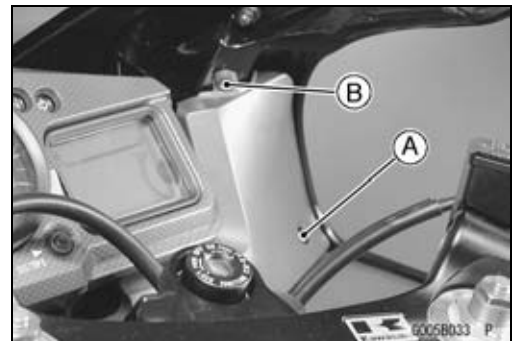

Upper Inner Covers (Left and Right) Installation

- Upper inner covers installation is the reversed of removal.
- Fit the projections [A] of upper inner covers [B] into the grommets [C] on the lower inner covers [D].

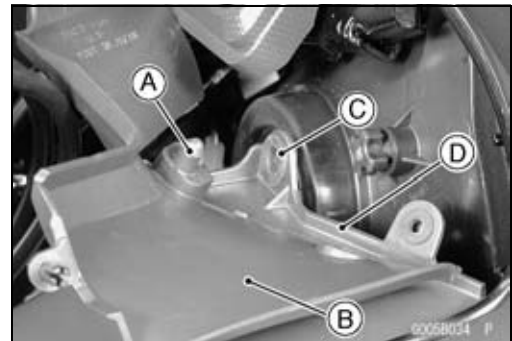

Lower Inner Covers (Left and Right) Removal

- Remove:
 - Fuel Tank Cover (see Fuel System (DFI) chapter)
 - Upper Inner Covers (see Upper Inner Covers Removal)
 - Rivet Screws [A]
 - Screws [B]
- Pull out the projections [C] of the inner covers [D] upward from each grommets of the ducts.

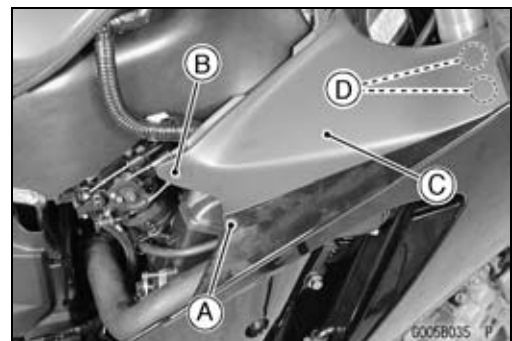

Fairings

Lower Inner Covers (Left and Right) Installation

- Lower inner covers installation is the reverse of removal.
- Insert the projections [A] of the lower inner covers into the holes [B] on the ducts.

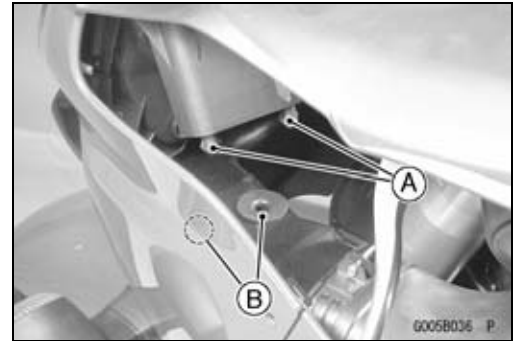

Upper Fairing Removal

- Remove:
 - Upper and Lower Inner Covers (see Upper and Lower Inner Covers Removal)
 - Wind Shield (see Wind Shield Removal)
- Remove the mounting screws [A] of left and right fairings.

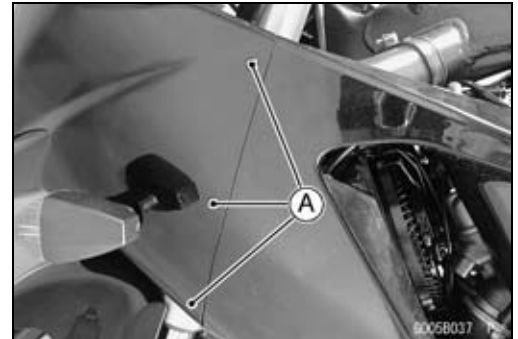

- Loosen the left and right air inlet duct clamp screws [A].

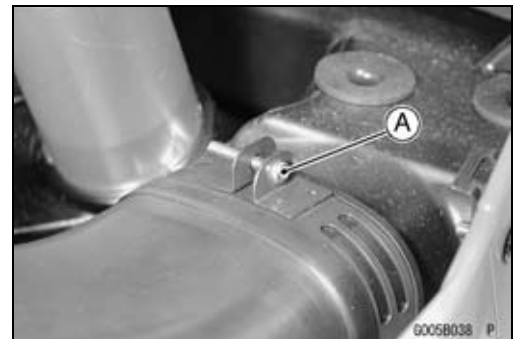

- Remove the nuts [A] and take off the left and right rear view mirrors.

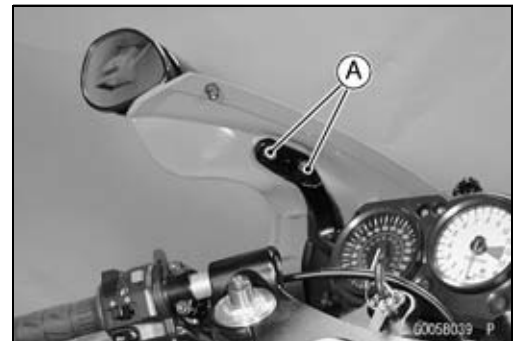

- Remove the projections [A] on the left and right upper inner fairings [B] from the grommets [C] on the left and right lower fairings [D] pulling out the lower portion inward of the upper inner fairings.

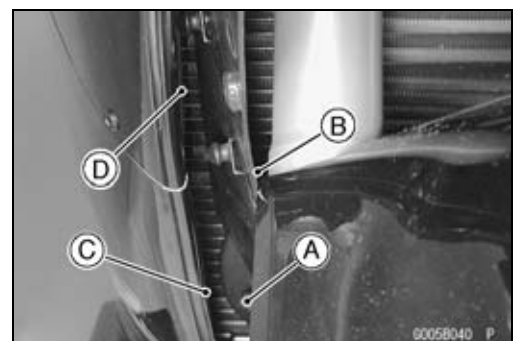

15-12 FRAME

Fairings

- Pull the upper fairing assembly forward and disconnect the headlight harness connector [A].

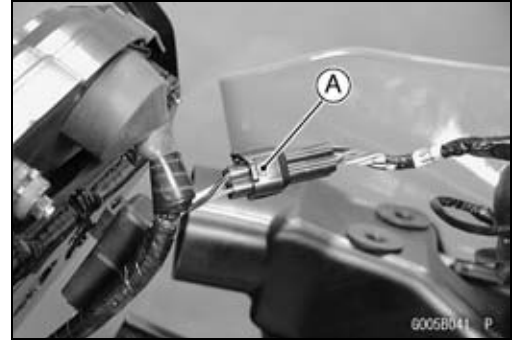

Upper Fairing Disassembly

- Remove the upper inner fairings [B] with loosening the screws [A].

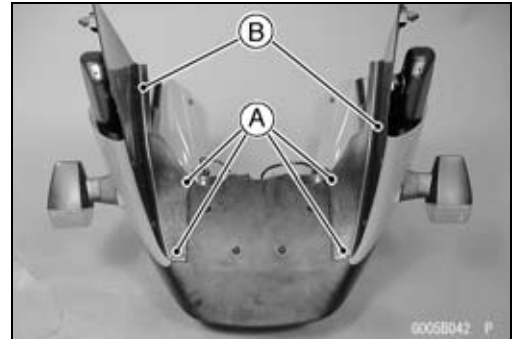

- Remove:
 - Front Turn Signal Connectors [A]
 - Headlight Connectors [B]
 - City Light Connector [C]
 - Headlight Harness Bracket [D]

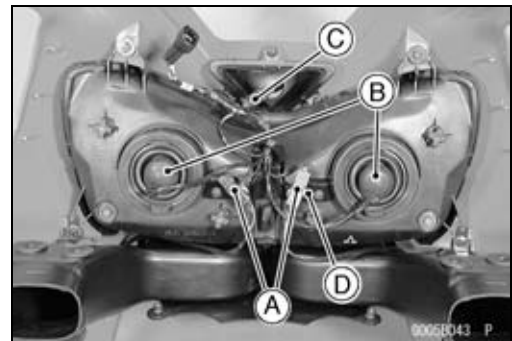

- Remove:
 - Headlight Mounting Bolts [A]
 - Headlight Mounting Screws [B]
 - Headlight Assembly [C]

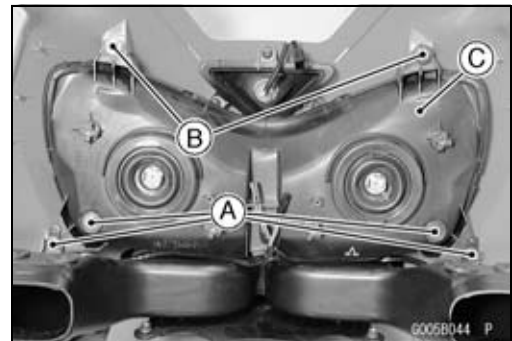

- Remove:
 - Screws [A]
 - City Light Assembly [B]

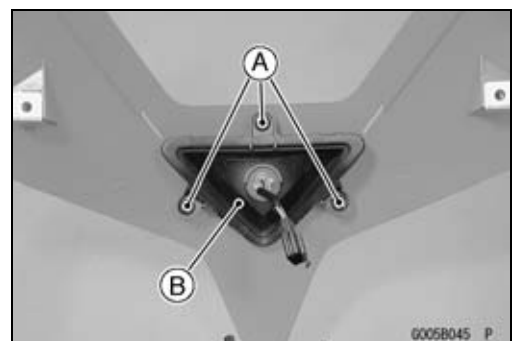

Fairings

- Remove the ducts [B] with the screws [A] taken off.

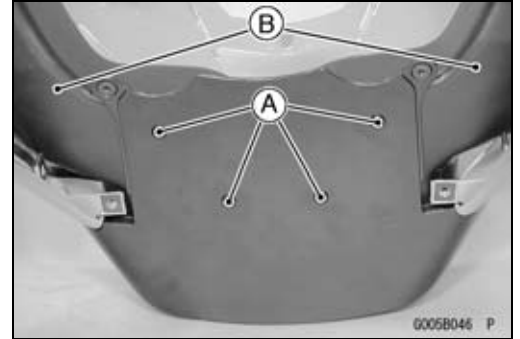

- Take off the screw [A] to remove the air inlet [B].

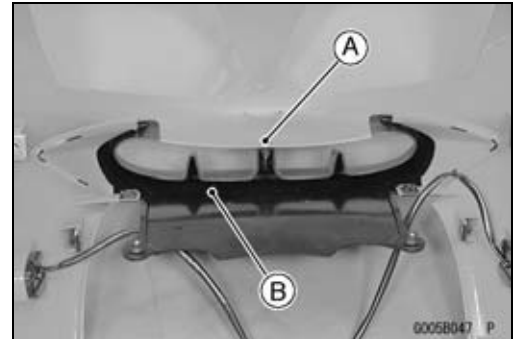

- Remove the screw [A] to take off the plate [B] and turn signal light.

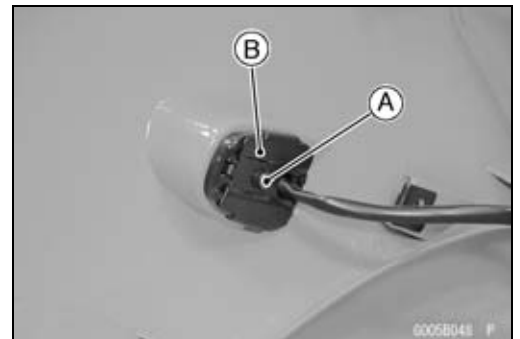

Upper Fairing Assembly

- Upper fairing assembly is the reversed of disassembly.
- Insert the projections [A] of the air inlet into the holes [B] of the upper fairing.

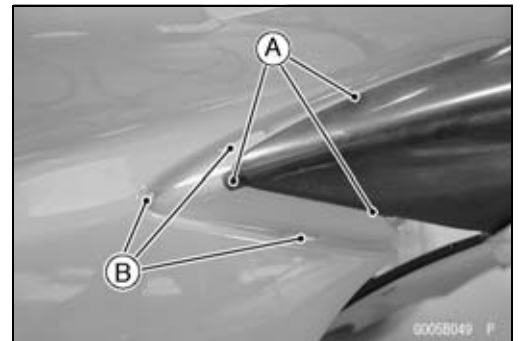

15-14 FRAME

Fairings

Hot Wind Cover Installation

- Install the hot wind cover [A] following the below.
 - Cooling Hose [B]
 - Clutch Cable [C]
 - Crankshaft Sensor Lead [J]
- Put in the lower part of the cover between the ribs [G] on the crankshaft sensor cover [H].
- Insert the pin [D] through the cover hole [E] to the bracket [F].

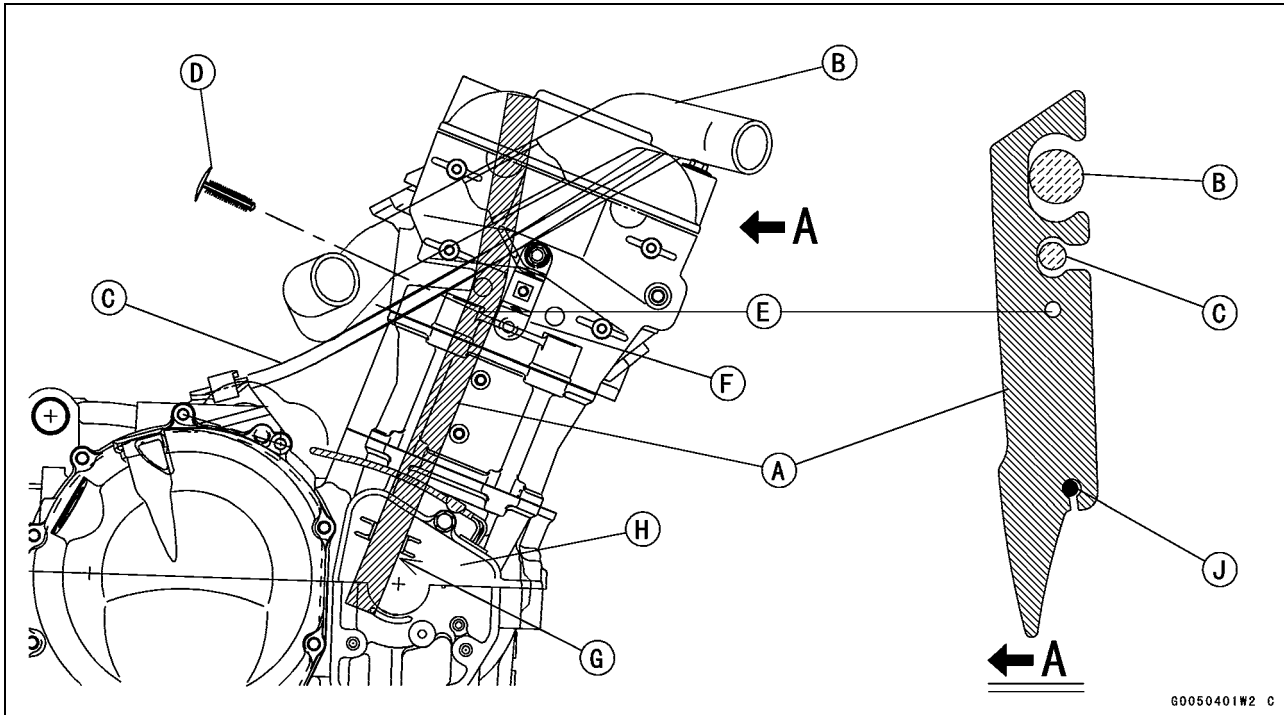

Fenders

Front Fender Removal

- Remove:
 - Brake Hose Clamps [A] (Left and Right)
 - Screws [B] (Front Part Screws with Washers)
 - Bolts [C]
 - Reflector [E] (for US and Canadian Models)
- Remove the front fender [D].

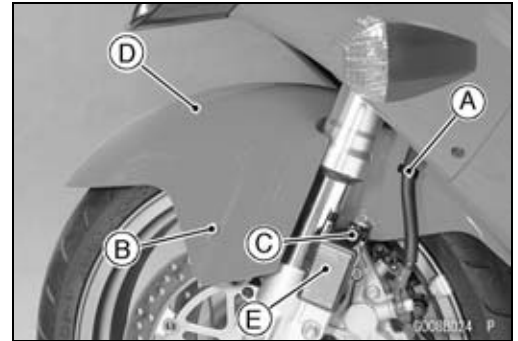

Front Fender Installation

- Install the front fender to the front fork.
- Tighten the screws and bolts.
- Install the brake hose clamps to the front fender holes.

Rear Fender Rear Removal

- Remove:
 - Rear Seat with cover (see Rear Seat Removal)
 - Front Seat (see Front Seat Removal)
 - Seat Cover (see Seat Cover Removal)
 - Storage Box (see Storage Box Removal)
- Set up the fuel tank (see Fuel System (DFI) chapter).
- Remove:
 - Nuts and Screws [A]

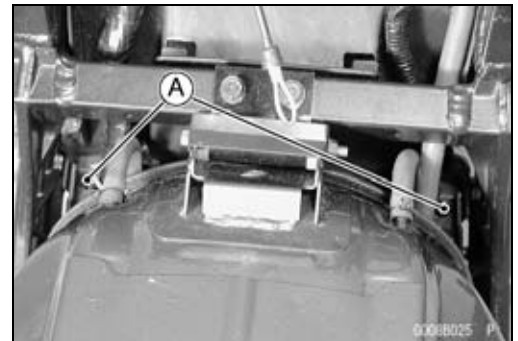

- Disconnect:
 - Rear Turn Signal Connectors [A] (Left and Right)
 - Tail/Brake Light Connector [B]
- Hang:
 - Canister (Californian Model Only)
 - ECU (see Fuel System (DFI) chapter)
- Remove:
 - Bolts [C]
- Pull backward the rear fender rear with the rear turn signal and reflector (for US and Canadian models).

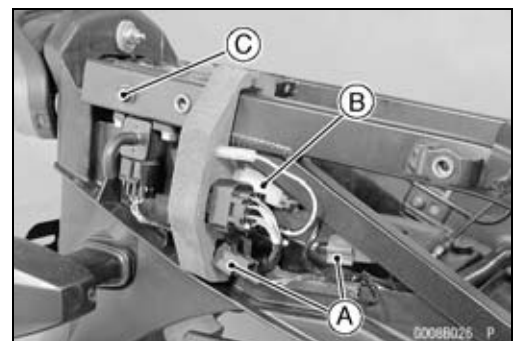

Rear Fender Rear Installation

- Install the front part of the rear fender rear under the rear fender front.

15-16 FRAME

Fenders

Rear Fender Front Removal

- Remove:
 - Rear Fender Rear (see Rear Fender Rear Removal)
 - Hose Clamps [A]
 - Separator [B]
- Remove the rear fender front.

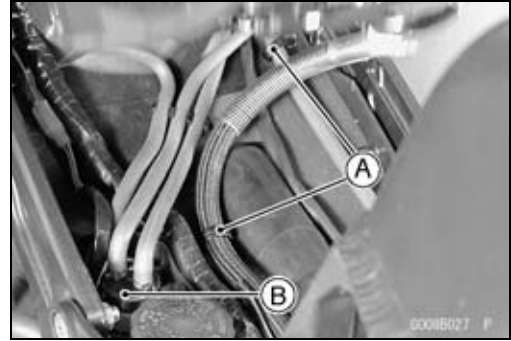

- Move the rear fender front backward until it stops, and then pull downward the right side of the rear fender front [A] to clear the brackets [B].



Rear Fender Front Installation

- Install the hose and harness clamps in accordance with Hose, Harness Routing section in General Information chapter.
- Insert both side grooves [A] of the rear fender front into the frame brackets [B].

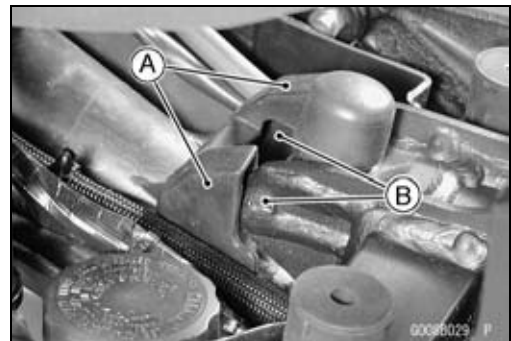

Rear Frame

Rear Frame Removal

- Remove:
 - Seats (see Front and Rear Seats Removal)
 - Rear Fender Front (see Rear Fender Front Removal)
 - ECU (Not Disconnect, see Fuel System (DFI) chapter)
- Disconnect:
 - Atmospheric Pressure Sensor Connector
 - Regulator/Rectifier Connectors
 - Muffler Mounting Bolt [A]
 - Fuel Tank Mount Bracket Bolts [B]
 - Rear Footpeg Holder Bolts [C]
 - Frame Bolts and Nuts [D]

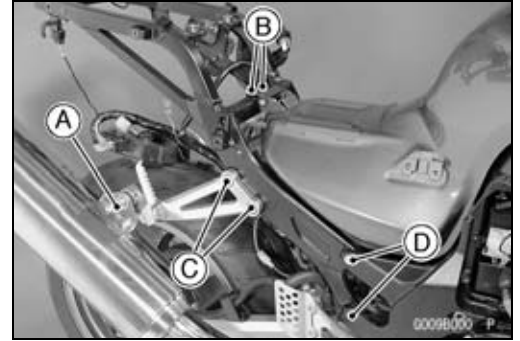

Rear Frame Installation

- Tighten the frame bolts and nuts,
 - Torque - Rear Frame Bolts and Nuts: 44 N·m (4.5 kgf·m, 32 ft·lb)
 - Rear Footpeg Holder Bolts: 34 N·m (3.5 kgf·m, 25 ft·lb)

Frame Inspection

- Visually inspect the frame for cracks, dents, bending, or warp.
- ★ If there is any damage to the frame, replace it.

⚠ WARNING

A repaired frame may fail in use, possibly causing an accident. If the frame is bent, dented, cracked, or warped, replace it.

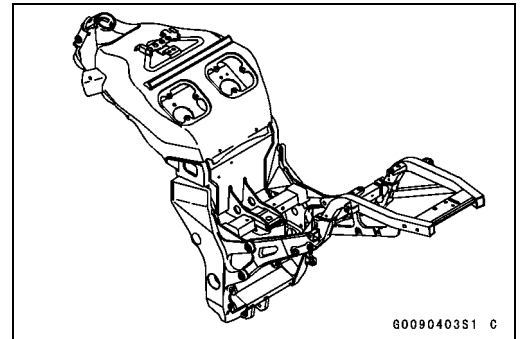

60090403S1 C

15-18 FRAME

Storage Box

Storage Box Removal

- Remove:
 - Seats (see this chapter)
 - Band [A]
 - Bolts [B]
 - Bolt [C]
- Pulling up the rear part of the box backward.

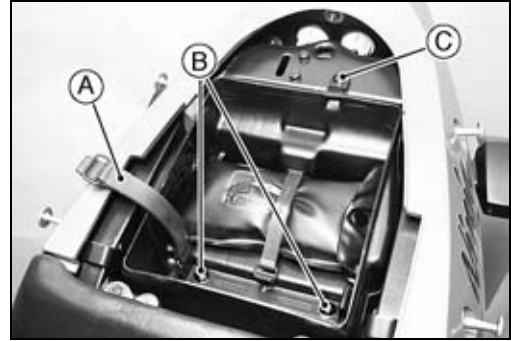

Storage Box Installation

- Insert the front part [A] of the box into the hook [B] of the rear fender rear.

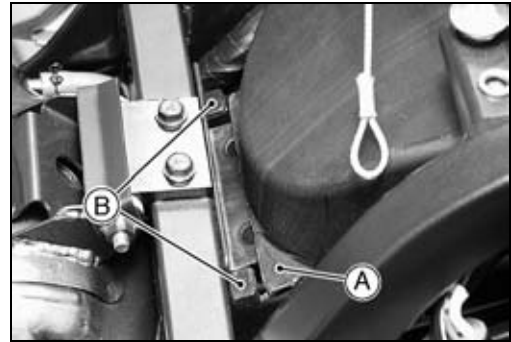

Side Stand

Side Stand Removal

- Raise the rear wheel off the ground with the stand.
- Disconnect the side stand switch lead connectors.
- Remove:
 - Side Stand Bolt [A]
 - Side Stand Bracket Bolts [B]
 - Spring [C]
 - Side Stand [D]
 - Side Stand Switch Bolt [E]

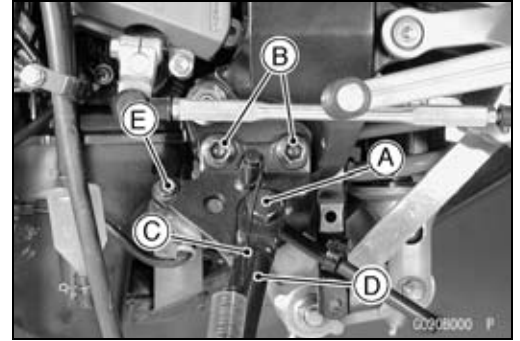

Side Stand Installation

- Apply grease to the sliding area [B] of the side stand [A].
- Tighten the bolt and lock them with the nut.
 - Torque - Side Stand Bolt: 44 N·m (4.5 kgf·m, 32 ft·lb)**
 - Side Stand Bracket Bolts: 49 N·m (5.0 kgf·m, 36 ft·lb)**
- Hook the spring
- Install the side stand switch.
- Apply a non-permanent locking agent to the thread of the switch bolt.

Torque - Side Stand Switch Bolt: 8.8 N·m (0.90 kgf·m, 78 in·lb)

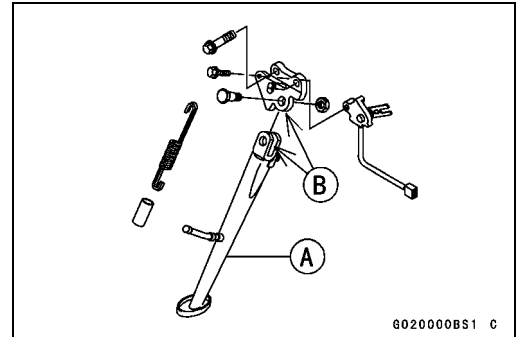

Electrical System

Table of Contents

Exploded View.....	16-3	Stick Coil (Ignition Coil together with Spark Plug Cap) Inspection	16-35
Specifications	16-8	Stick Coil Primary Peak Voltage Inspection.....	16-36
Parts Location.....	16-10	Spark Plug Removal	16-36
Precautions.....	16-11	Spark Plug Installation	16-37
Electrical Wiring.....	16-13	Spark Plug Cleaning and Inspection.....	16-37
Wiring Inspection	16-13	Spark Plug Gap Inspection	16-37
Battery	16-14	Interlock Operation Inspection	16-37
Battery Removal	16-14	IC Igniter Inspection	16-38
Battery Installation	16-15	Ignition System Inspection	16-39
Electrolyte Filling.....	16-16	Electric Starter System	16-42
Initial Charge.....	16-18	Starter Motor Removal.....	16-42
Precautions	16-18	Starter Motor Installation.....	16-42
Interchange.....	16-19	Starter Motor Disassembly.....	16-43
Charging Condition Inspection.....	16-19	Starter Motor Assembly	16-43
Refreshing Charge.....	16-19	Brush Inspection	16-44
Charging System	16-21	Commutator Cleaning and Inspection.....	16-44
Alternator Cover Removal.....	16-21	Armature Inspection.....	16-45
Alternator Cover Installation.....	16-21	Brush Lead Inspection	16-45
Stator Coil Removal	16-21	Brush Plate and Terminal Bolt Inspection.....	16-45
Stator Coil Installation	16-22	Starter Relay Inspection.....	16-45
Alternator Rotor Removal	16-23	Lighting System.....	16-49
Alternator Rotor Installation	16-23	Headlight Beam	
Alternator Inspection	16-24	Horizontal/Vertical Adjustment ..	16-49
Regulator/Rectifier Inspection.....	16-25	Headlight Bulbs (Left and Right) Replacement.....	16-50
Regulator/Rectifier Output Voltage Inspection.....	16-28	City Light Bulb Replacement.....	16-50
Ignition System	16-31	Tail/Brake Light Bulbs Replacement.....	16-51
Crankshaft Sensor Removal	16-31	Tail/Brake Light Lens Assembly Replacement.....	16-51
Crankshaft Sensor Installation	16-32	Headlight Relays (High/Low) Inspection.....	16-52
Crankshaft Sensor Inspection.....	16-32	Turn Signal Relay Inspection	16-54
Crankshaft Sensor Peak Voltage Inspection.....	16-32	Air Switching Valve (ZX1200-B3)	16-57
Camshaft Position Sensor Removal.....	16-33	Air Switching Valve Operation Test.....	16-57
Camshaft Position Sensor Installation	16-33	Air Switching Valve Unit Test	16-57
Camshaft Position Sensor Inspection.....	16-34	Radiator Fan System.....	16-58
Camshaft Position Sensor Peak Voltage Inspection.....	16-34	Fan System Circuit Inspection	16-58
Stick Coil (Ignition Coil together with Spark Plug Cap) Removal ..	16-35	Fan Motors Inspection	16-58
Stick Coil (Ignition Coil together with Spark Plug Cap) Installation	16-35	Fan Relay Removal	16-58

16-2 ELECTRICAL SYSTEM

Fan Relay Inspection	16-59	Junction Box	16-95
Meter	16-60	Junction Box Fuse Circuit Inspection.....	16-95
Meter Unit Removal	16-60	Starter Circuit/Headlight Relay Inspection.....	16-95
Meter Unit Disassembly	16-60	Diode Circuit Inspection	16-96
Bulbs Replacement.....	16-60	Fuse.....	16-98
Meter Unit Inspection	16-61	30 A Main Fuse Removal.....	16-98
Immobilizer System (Equipped Models) (ZX1200-B3)	16-70	30 A Headlight/Fan Fuse Removal	16-98
Operational Cautions	16-70	Junction Box Fuse Removal	16-98
Key Registration.....	16-70	15 A ECU Fuse Removal.....	16-99
Immobilizer System Parts Replacement.....	16-86	Fuse Installation.....	16-99
Immobilizer System Inspection	16-88	Fuse Inspection.....	16-99
Switches and Sensors	16-89	Wiring Diagram (U.S.A. and Canada)	16-100
Front Brake Light Switch Inspection.....	16-89	Wiring Diagram (Australia/ZX1200-B2: H, HU, HR models).....	16-102
Rear Brake Light Switch Check/Adjustment	16-89	Wiring Diagram (Malaysia)	16-104
Switch Inspection	16-89	Wiring Diagram (Other than U.S.A., Canada, Australia, and Malaysia)...	16-106
Radiator Fan Switch Inspection ...	16-90	Wiring Diagram (ZX1200-B3: U.S.A., and Canada).....	16-108
Water Temperature Sensor Inspection.....	16-91	Wiring Diagram (ZX1200-B3: Other than U.S.A., Canada, Hong Kong, Kuwait and Malaysia).....	16-110
Speed Sensor Removal	16-91	Wiring Diagram (ZX1200-B3: Hong Kong, Kuwait)	16-112
Speed Sensor Installation	16-92	Wiring Diagram (ZX1200-B3: Malaysia)	16-114
Speed Sensor Inspection.....	16-92		
Fuel Level Sensor Inspection.....	16-92		
Fuel Reserve Switch Inspection (1).....	16-93		
Fuel Reserve Switch Inspection (2).....	16-94		

Exploded View

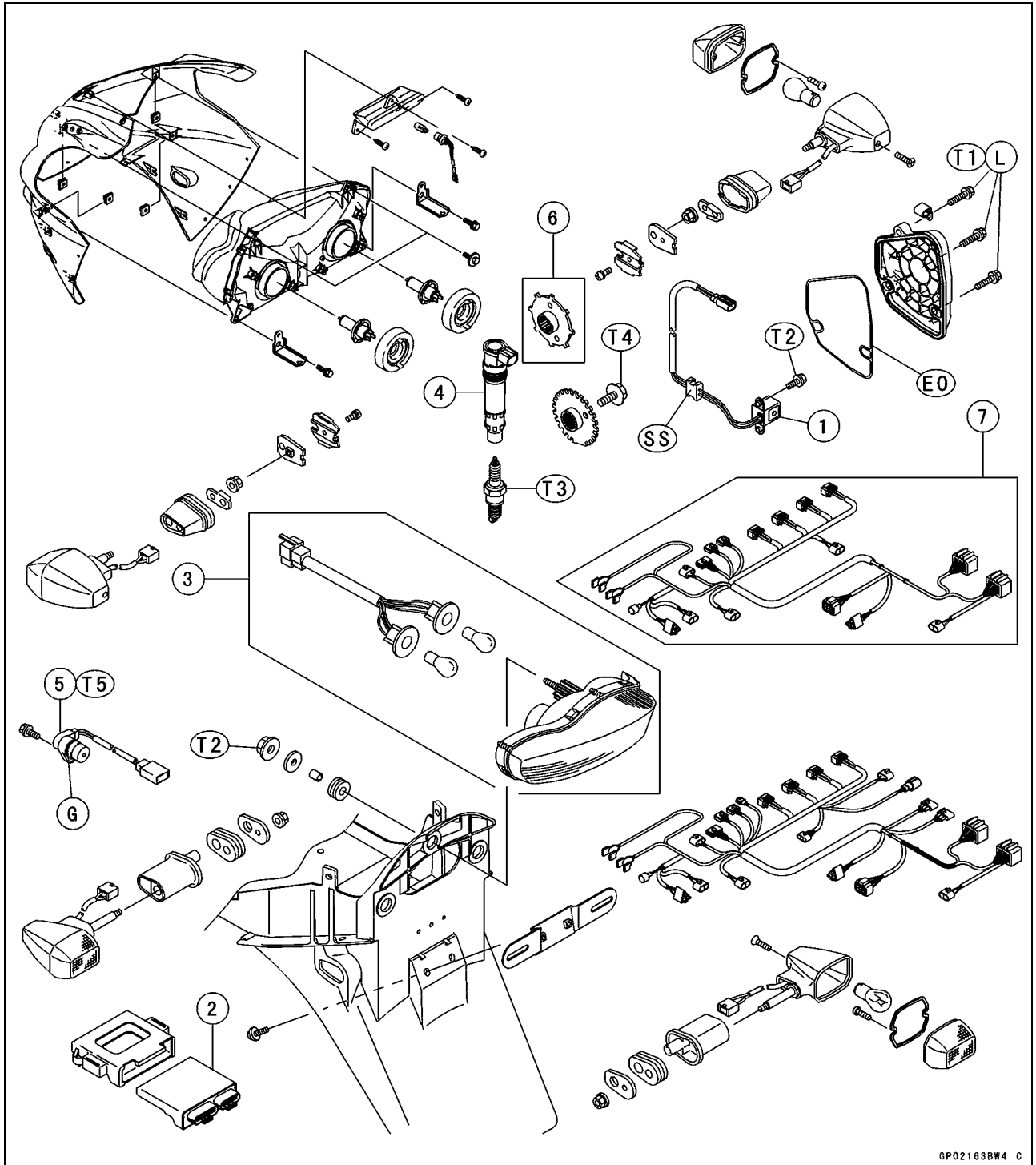

GP02163BW4 C

- 1. Crankshaft Sensor
- 2. ECU
- 3. Tail/Brake Lights
- 4. Stick Coils
- 5. Camshaft Position Sensor
- 6. Timing Rotor (ZX1200-B1/B2)
- 7. Harness (ZX1200-B1/B2)
- T1: 15 N·m (1.5 kgf·m, 11 ft·lb)

- T2: 6.0 N·m (0.60 kgf·m, 53 in·lb)
- T3: 13 N·m (1.3 kgf·m, 115 in·lb)
- T4: 39 N·m (4.0 kgf·m, 29 ft·lb)
- T5: 12 N·m (1.2 kgf·m, 106 in·lb)
- EO: Apply engine oil.
- G: Apply grease.
- L: Apply a non-permanent locking agent.
- SS: Apply silicone sealant.

16-4 ELECTRICAL SYSTEM

Exploded View

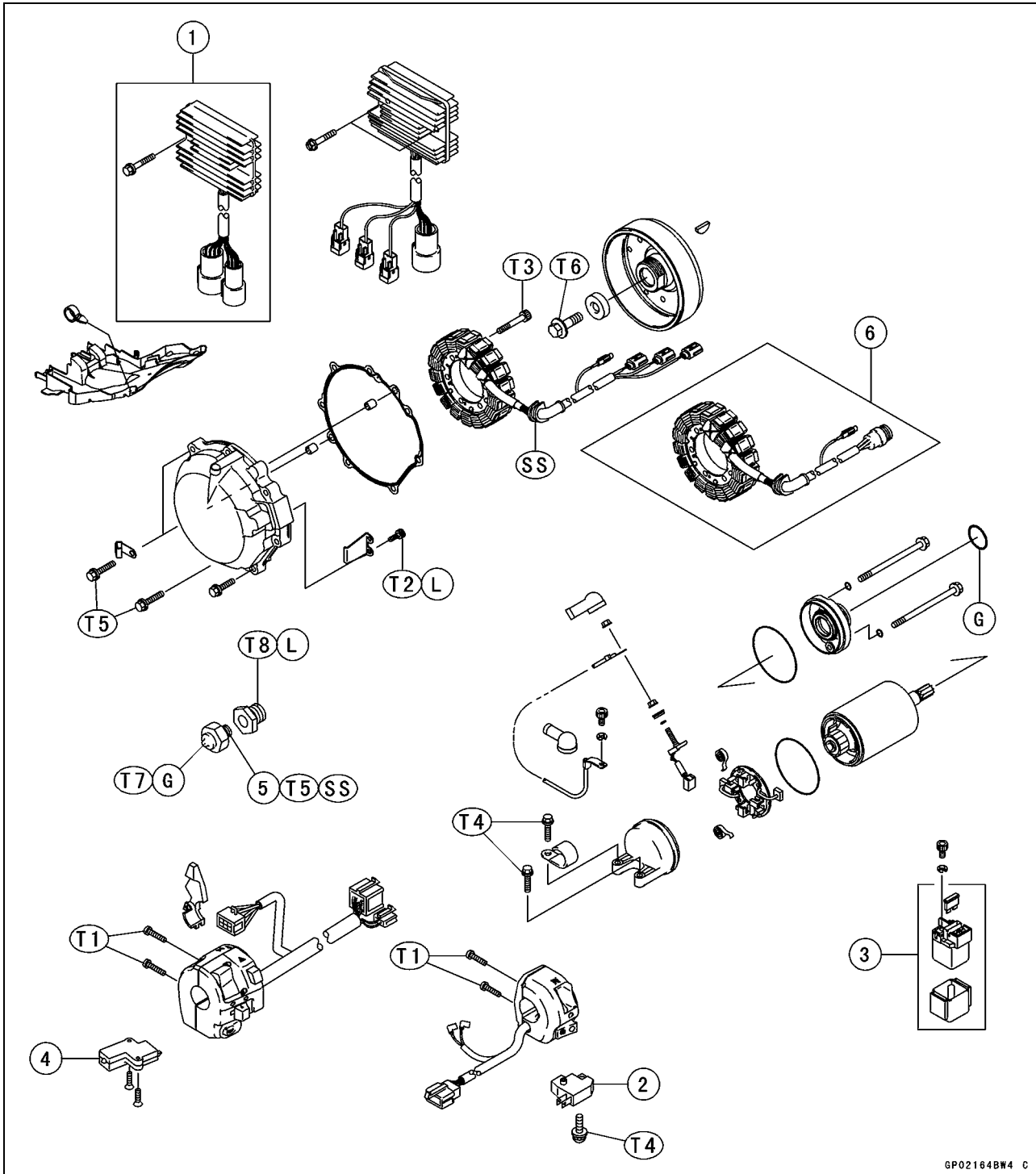

GP02164BW4 C

- 1. Regulator/rectifier (ZX1200-B1/B2)
- 2. Front Brake Light Switch
- 3. Starter Relay/Main Fuse
- 4. Starter Lockout Switch
- 5. Oil Pressure Switch
- 6. Stator (ZX1200-B1/B2)
- T1: 3.5 N·m (0.36 kgf·m, 31 in·lb)
- T2: 8.5 N·m (0.87 kgf·m, 75 in·lb)
- T3: 22 N·m (2.2 kgf·m, 16 ft·lb)

- T4: 12 N·m (1.2 kgf·m, 106 in·lb)
- T5: 15 N·m (1.5 kgf·m, 11 ft·lb)
- T6: 110 N·m (11 kgf·m, 81 ft·lb)
- T7: 1.5 N·m (0.15 kgf·m, 13 in·lb)
- T8: 20 N·m (2.0 kgf·m, 15 ft·lb)
- G: Apply grease.
- L: Apply a non-permanent locking agent.
- SS: Apply silicone sealant.

16-6 ELECTRICAL SYSTEM

Exploded View

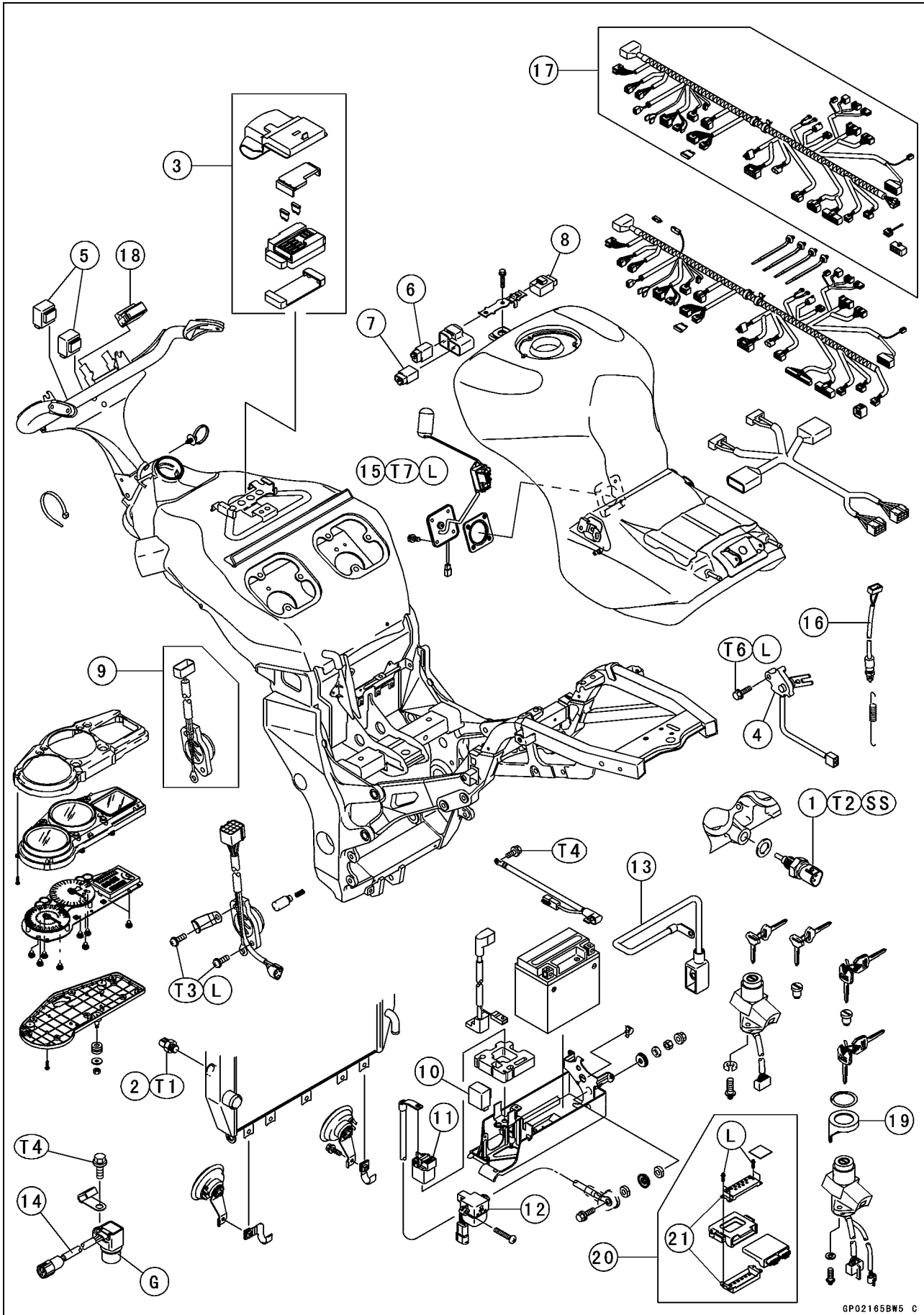

Exploded View

1. Water Temperature Sensor
 2. Radiator Fan Switch
 3. Junction Box
 4. Side Stand Switch
 5. Headlight Relays
 6. Fuel Pump Relay
 7. Fan Relay
 8. ECU Relay
 9. Gear Position Switch (ZX1200-B1/B2)
 10. Turn Signal Relay
 11. Starter Relay and Main Fuse
 12. Vehicle-down Sensor
 13. Jump Starting Cable
 14. Speed Sensor
 15. Fuel Level Sensor
 16. Rear Brake Light Switch
 17. Main Harness (ZX1200-B1/B2)
 18. Immobilizer Amplifier
 19. Immobilizer Antenna
 20. Immobilizer Models
 21. European Model only
- T1: 24 N·m (2.4 kgf·m, 17 ft·lb)
T2: 25 N·m (2.5 kgf·m, 18 ft·lb)
T3: 4.0 N·m (0.40 kgf·m, 35 in·lb)
T4: 10 N·m (1.0 kgf·m, 89 in·lb)
T5: 12 N·m (1.2 kgf·m, 106 in·lb)
T6: 8.8 N·m (0.90 kgf·m, 78 in·lb)
T7: 6.9 N·m (0.70 kgf·m, 61 in·lb)
- G: Apply grease.
L: Apply a non-permanent locking agent.
SS: Apply silicone sealant.

16-8 ELECTRICAL SYSTEM

Specifications

Item	Standard
Battery Type Capacity Voltage	Sealed battery 12 V 12 Ah 12.6 V or more
Charging System Type Alternator Output Voltage Stator Coil Resistance Charging Voltage (Regulator/rectifier Output Voltage)	Three-phase AC 85 ~ 120 V @4 000 r/min (rpm) 0.3 ~ 0.5 Ω @20°C (68°F) 14.2 ~ 15.2 V
Ignition System Crankshaft Sensor Resistance Crankshaft Sensor Peak Voltage Camshaft Position Sensor Resistance Camshaft Position Sensor Peak Voltage Interlock Operation Voltage Stick Coil: Primary Winding Resistance ZX1200-B1/B2 ZX1200-B3 Secondary Winding Resistance ZX1200-B1/B2 ZX1200-B3 Primary Peak Voltage ZX1200-B1/B2 ZX1200-B3 Spark Plug: Spark Plug Gap	423 ~ 517 Ω 3.6 V or more 400 ~ 460 Ω 0.2 V or more 4 V or more 0.85 ~ 1.15 Ω 1.04 ~ 1.56 Ω 9.2 ~ 13.8 k Ω 10.8 ~ 16.2 k Ω 80 V or more 88 V or more 0.7 ~ 0.9 mm (0.028 ~ 0.035 in.)
Electric Starter System Starter Motor: Brush Length Commutator Diameter	 12 mm (0.47 in.), Service limit 8.5 mm (0.33 in.) 28 mm (1.10 in.), Service limit 27 mm (1.06 in.)
Switch and Sensor Rear Brake Light Switch Timing Engine Oil Pressure Switch Connections Fan Switch Resistance: Rising Temperature Falling Temperature Water Temperature Sensor Resistance	ON after about 10 mm (0.39 in.) pedal travel When engine is stopped: ON When engine is running: OFF From OFF to ON @ 93 ~ 103°C (199 ~ 217°F) Fan stops with the temperature 3 ~ 8°C (38 ~ 46°F) lower than the operation temperature range. ON: Less than 0.5 Ω OFF: More than 10 M Ω in the text

Specifications

Item	Standard
Fuel Level Sensor Resistance: Full Position Empty Position	 8 ~ 10 Ω 122 ~ 126 Ω

Special Tools - Rotor Puller: 57001-1216

Flywheel Holder: 57001-1313

Flywheel and Pulley Holder: 57001-1343

Hand Tester: 57001-1394

Flywheel Puller Assembly: 57001-1405

Lead Wire – Voltage Regulator Adapter: 57001-1448

Lead Wire – Peak Voltage Adapter: 57001-1449

Needle Adapter Set: 57001-1457

Key Registration Unit: 57001-1582

Pulley Holder, Grip: 57001-1591

Rotor Holder: 57001-1592

Sealant - Kawasaki Bond (Silicone Sealant): 56019-120

16-10 ELECTRICAL SYSTEM

Parts Location

- Starter Lockout Switch [A]
- Camshaft Position Sensor [B]
- Fuel Pump Relay [C]
- Radiator Fan Relay [D]
- Inlet Air Pressure Sensor [E]
- Throttle Sensor [F]
- Starter Motor [G]
- Radiator Fan Switch [H]
- Alternator [I]
- Oil Pressure Switch [J]
- Speed Sensor [K]

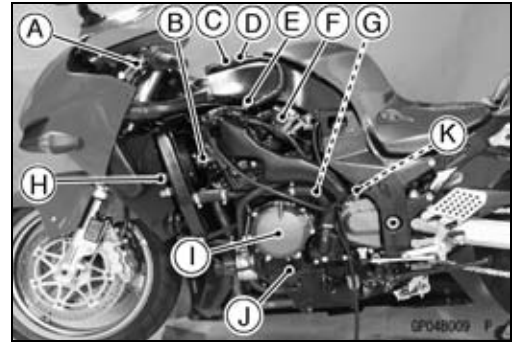

- Inlet Air Temperature Sensor [A]
- Battery [B]
- ECU (Electronic Control Unit) [C]
- Regulator/Rectifier [D]
- Gear Position Switch [E]
- Side Stand Switch [F]

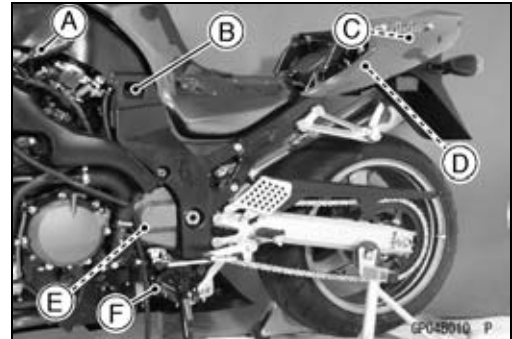

- Battery [A]
- Water Temperature Sensor [B]
- ECU Main Relay [C]
- ECU Fuse [D]
- Junction Box [E]
- Stick Coils (Ignition Coils) [F]
- Front Brake Light Switch [G]
- Headlight Relays (High and Low Beam) [H]
- Crankshaft Sensor [I]

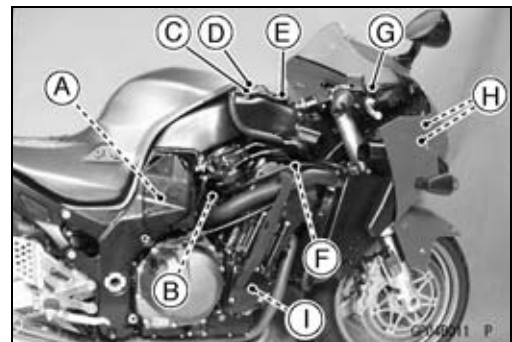

- Atmospheric Pressure Sensor [A]
- Self-diagnosis Indicator Terminal [B]
- Fuel Pump [C]
- Rear Brake Light Switch [D]

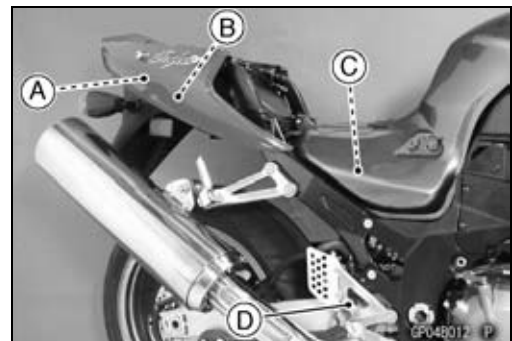

- Battery [A]
- Turn Signal Relay [B]
- Vehicle-down Sensor [C]
- Headlight/Fan Fuse [D]
- Main Fuse [E]
- Starter Relay [F]
- Jump Starting Cable [G]

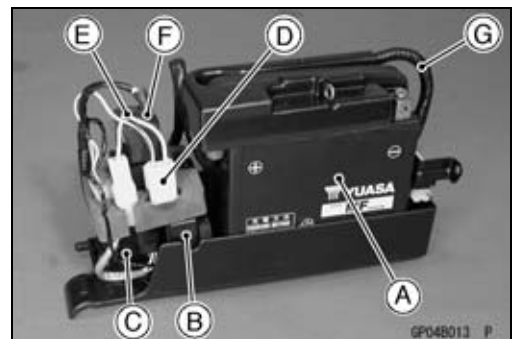

Precautions

There are a number of important precautions that should be followed servicing electrical systems.

- Do not reverse the battery cable connections. This will burn out the diodes on the electrical parts.
- Always check battery condition before condemning other parts of an electrical system. A fully charged battery is a must for conducting accurate electrical system tests.
- The electrical parts should never be struck sharply, as with a hammer, or allowed to fall on a hard surface. Such a shock to the parts can damage them.
- To prevent damage to electrical parts, do not disconnect the battery cables or any other electrical connections when the ignition switch is on, or while the engine is running.
- Because of the large amount of current, never keep the starter button pushed when the starter motor will not turn over, or the current may burn out the starter motor windings.
- Do not use a meter illumination bulb rated for other than voltage or wattage specified in the wiring diagram, as the meter or gauge panel could be warped by excessive heat radiated from the bulb.
- Take care not to short the leads that are directly connected to the battery positive (+) terminal to the chassis ground.
- Troubles may involve one or in some cases all items. Never replace a defective part without determining what CAUSED the failure. If the failure was caused by some other item or items, they must be repaired or replaced, or the new replacement will soon fail again.
- Make sure all connectors in the circuit are clean and tight, and examine leads for signs of burning, fraying, etc. Poor leads and bad connections will affect electrical system operation.
- Measure coil and winding resistance when the part is cold (at room temperature).

○ Color Codes:

BK: Black	G: Green	P: Pink
BL: Blue	GY: Gray	PU: Purple
BR: Brown	LB: Light blue	R: Red
CH: Chocolate	LG: Light green	W: White
DG: Dark green	O: Orange	Y: Yellow

○ Electrical Connectors

Female Connectors [A]

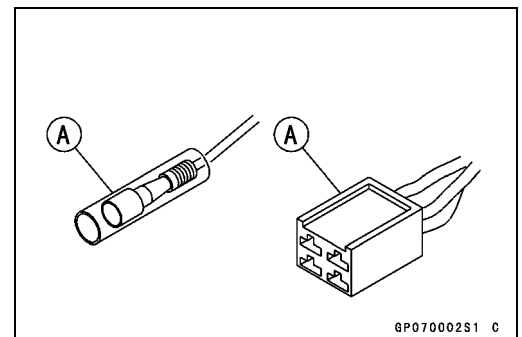

16-12 ELECTRICAL SYSTEM

Precautions

Male Connectors [B]

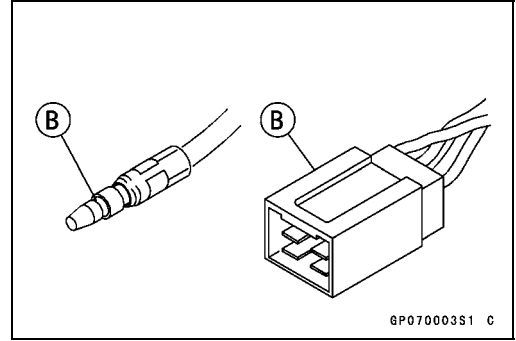

Electrical Wiring

Wiring Inspection

- Visually inspect the wiring for signs of burning, fraying, etc.
- ★ If any wiring is poor, replace the damaged wiring.
- Pull each connector [A] apart and inspect it for corrosion, dirt, and damage.
- ★ If the connector is corroded or dirty, clean it carefully. If it is damaged, replace it.
- Check the wiring for continuity.
- Use the wiring diagram to find the ends of the lead which is suspected of being a problem.
- Connect the hand tester between the ends of the leads.

Special Tool - Hand Tester: 57001-1394

- Set the tester to the $\times 1 \Omega$ range, and read the tester.
- ★ If the tester does not read 0Ω , the lead is defective. Replace the lead or the wiring harness [B] if necessary.

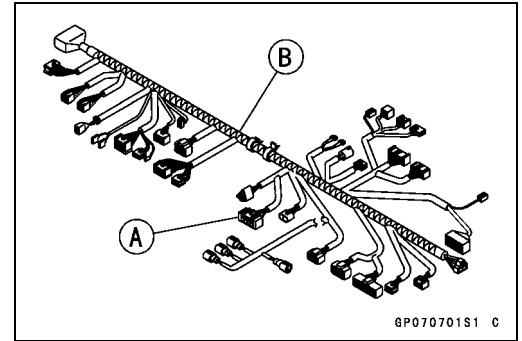

16-14 ELECTRICAL SYSTEM

Battery

Battery Removal

CAUTION

Do not disconnect the battery cables or any other electrical connections when the ignition switch is ON, as this could damage the ECU (Electronic Control Unit).
Never reverse the connections of the battery, this could damage the ECU.

- Turn off the ignition switch.
- Remove:
 - Seats (see Frame chapter)
 - Fuel Tank Cover (see Fuel System (DFI) chapter)
 - Battery Compartment Cover Bolts [A]
 - Battery Compartment Cover [B]
- Slightly pull out the battery tray [A].
- Slide out terminal cover [B] to disconnect the negative (-) cable [C] and release the leads and cable from the clamp [D] on the battery tray.
- Slide out covers [A] and [C] to disconnect the starter motor cable [B] and main harness connector [D].
- Disconnect the main negative harness connector [E].
- Remove the battery tray along with the battery from the battery compartment.
- Unhook the rubber band [B] and remove the battery cover [A].

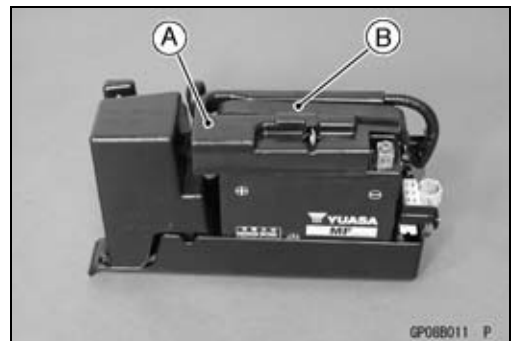
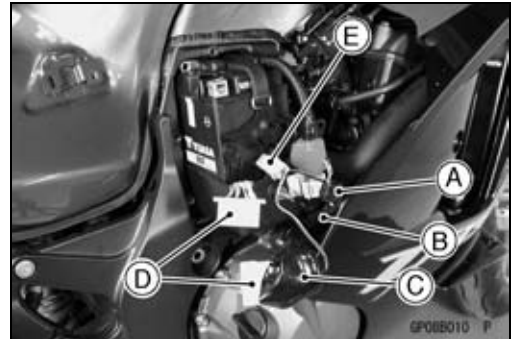
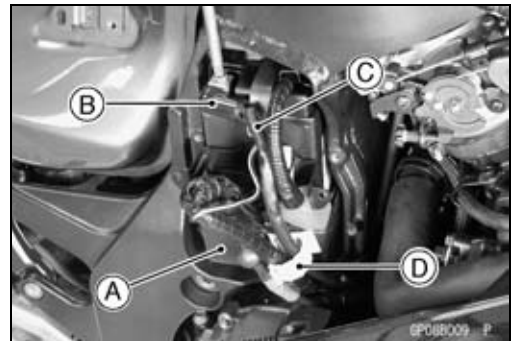
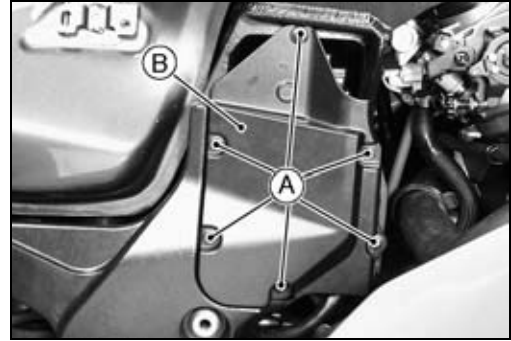

Battery

- Remove:
 - Positive (+) Cable [A]
 - Battery [B]

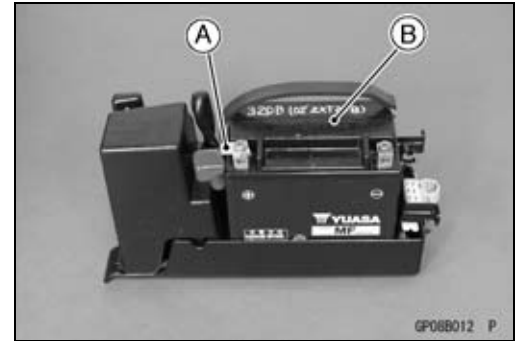

Battery Installation

- Place the battery in the tray.

NOTE

○Put the (+) terminal side of the battery on the (+) symbol [A] and the (-) terminal side on the (-) symbol [B].

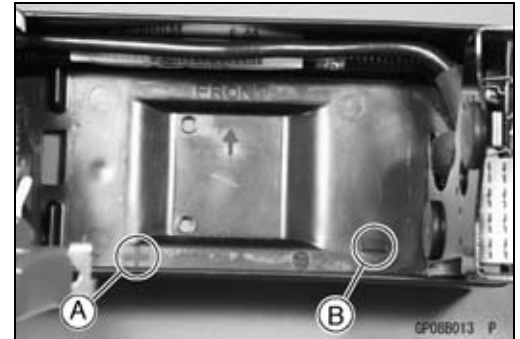

- Connect the capped cable [A] to the (+) terminal.
- Put light coat of grease on the (+) terminal to prevent corrosion.
- Cover the (+) terminal with its protective cap [B].
- Install:
 - Battery Cover
 - Rubber Band

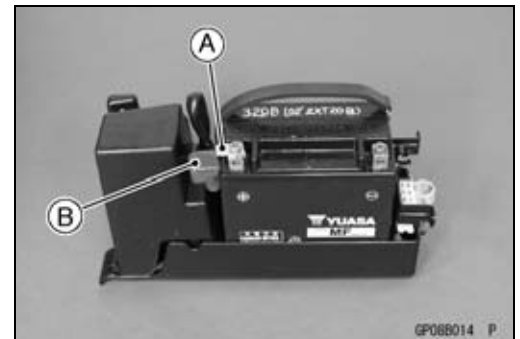

- Insert the battery tray along with the battery into the battery compartment.
- Connect the capped starter motor cable [A] to the terminal, tighten the nut and cover the cap.
- Cross the starter motor cable over the main harness.
- Connect the black cable [B] to the (-) terminal.
- Put light coat of grease on the (-) terminal to prevent corrosion and cover the cap.
- Connect the connectors [C] and [D], cover the cap to the connector [C].

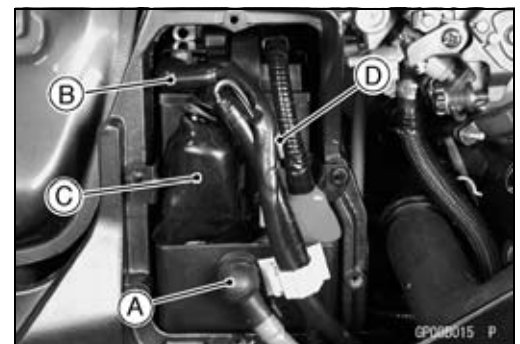

- Confirm that the projection [A] of the battery tray fits into the hole in the left side of the frame.
- Install:
 - Removed Parts



16-16 ELECTRICAL SYSTEM

Battery

Electrolyte Filling

- Make sure that the model name [A] of the electrolyte container matches the model name [B] of the battery. These names must be the same.

Battery Model Name for ZX1200-B1 ~ B3: YTX14-BS

CAUTION

Be sure to use the electrolyte container with the same model name as the battery since the electrolyte volume and specific gravity vary with the battery type. This is to prevent overfilling of the electrolyte, shorting the battery life, and deterioration of the battery performance.

- Check to see that there is no peeling, tears or holes in the seal sheet on the top of the battery.
- Place the battery on a level surface.
- Remove the seal sheet [A].

CAUTION

Do not remove the seal sheet sealing the filler ports [B] until just before use.

NOTE

○A battery whose seal sheet has any peeling, tears, or holes, requires a refreshing charge (initial charge).

- Take the electrolyte container out of the plastic bag.
- Detach the seal cap [A] from the container.

NOTE

○Do not discard the seal cap because it is used as the battery plugs later.

○Do not peel back or pierce the seals [B] on the container.

- Place the electrolyte container upside down aligning the six seals with the six battery filler ports.
- Push the container down strongly enough to break the seals. Now the electrolyte should start to flow into the battery.

NOTE

○Do not tilt the container as the electrolyte flow may be interrupted.

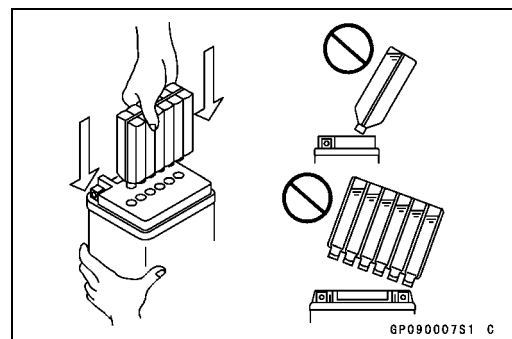
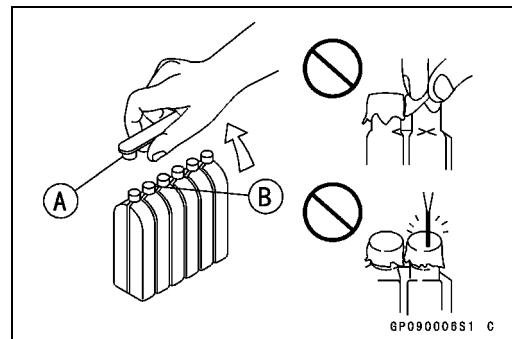
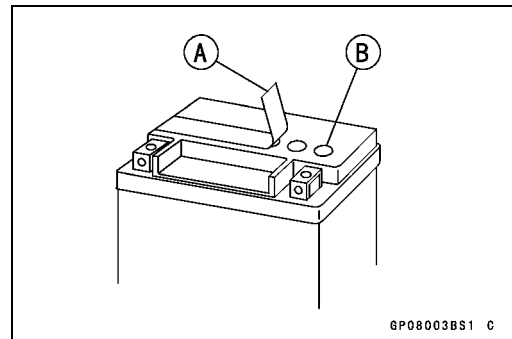
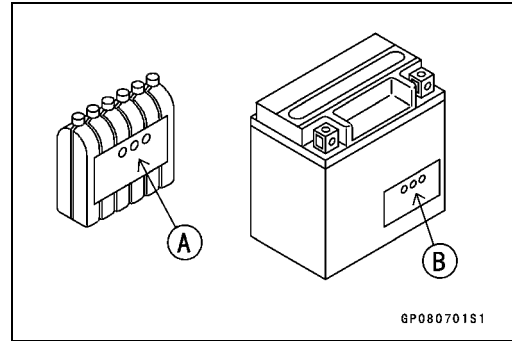

Battery

- Make sure air bubbles [A] are coming up from all six filler ports.
- Leave the container this way for 5 minutes or longer.

NOTE

- If no air bubbles are coming up from a filler port, tap [B] the bottom of the container two or three times. Never remove the container from the battery.

CAUTION

Fill the electrolyte into the battery until the container is completely emptied.

- Be certain that all the electrolyte has flowed out.
- Tap the bottom the same way as above if there is any electrolyte left in the container.
- Now pull the container gently out of the battery.
- Let the battery sit for **20** minutes. During this time, the electrolyte permeates the special separators and the gas generated by chemical reaction is released.
- Fit the seal cap [A] tightly into the filler ports until the seal cap is at the same level as the top of the battery.

NOTE

- Do not hammer. Press down evenly with both hands.

WARNING

Once you installed the seal cap after filling the battery, never remove it, nor add any water or electrolyte.

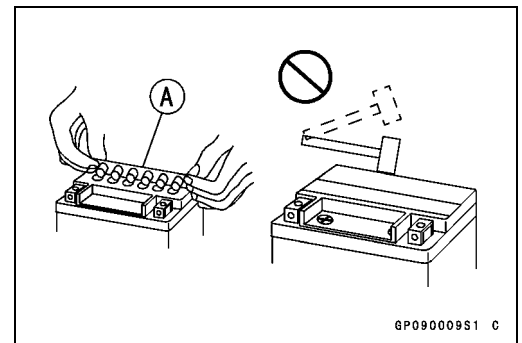
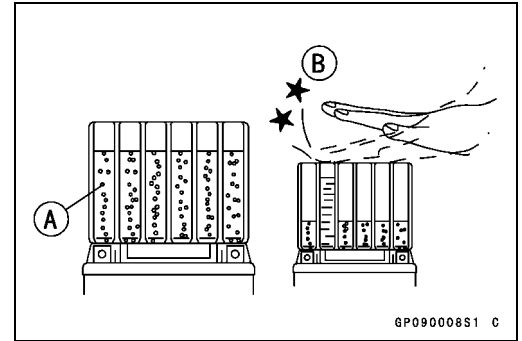

16-18 ELECTRICAL SYSTEM

Battery

Initial Charge

While a Sealed battery can be used after only filling with electrolyte, a battery may not be able to sufficiently move a starter motor to start an engine in the cases shown in the table below, where an initial charge is required before use. However, if a battery shows a terminal voltage of 12.6 V or more, using a digital volt meter, after 10 minutes of filling, no initial charge is necessary.

NOTE

○ To measure battery terminal voltage, use a digital voltmeter which can be read one decimal place voltage.

Condition requiring initial charge	Charging method
At low temperature (lower than 0°C)	1.4 A × 2 ~ 3 hours
Battery has been stored under high temperature and humidity.	1.4 A × 15 ~ 20 hours
Seal sheet has been removed, or broken – peeling, tear or hole.	
Battery two or more years old from date of manufacture. Battery manufacturing date is printed on battery top. Example) <u>12</u> <u>10</u> <u>01</u> <u>T1</u> Day Month Year Mfg. location	

Precautions

1) No need of topping-up

No topping-up is necessary in this battery until it ends its life under normal use. Forcibly prying off the seal cap to add water is very dangerous. Never do that.

2) Refreshing charge

If an engine will not start, a horn sounds weak, or lamps are dim, it indicates the battery has been discharged. Give refresh charge for 5 to 10 hours with charge current shown in the specification (see this chapter).

When a fast charge is inevitably required, do it following precisely the maximum charge current and time conditions indicated on the battery.

CAUTION

This battery is designed to sustain no unusual deterioration if refresh-charged according to the method specified above. However, the battery's performance may be reduced noticeably if charged under conditions other than given above. Never remove the seal cap during refresh charge.

If by chance an excessive amount of gas is generated due to overcharging, the relief valve releases the gas to keep the battery normal.

3) When you do not use the motorcycle for months:

Give a refresh charge before you store the motorcycle and store it with the negative cable removed. Give a refresh charge **once a month** during storage.

4) Battery life:

If the battery will not start the engine even after several refresh charges, the battery has exceeded its useful life. Replace it (Provided, however, the vehicle's starting system has no problem).

WARNING

Keep the battery away from sparks and open flames during charging, since the battery gives off an explosive gas mixture of hydrogen and oxygen. When using a battery charger, connect the battery to the charger before turning on the charger.

This procedure prevents sparks at the battery terminals which could ignite any battery gases.

No fire should be drawn near the battery, or no terminals should have the tightening loosened.

The electrolyte contains sulfuric acid. Be careful not to have it touch your skin or eyes. If touched, wash it off with liberal amount of water. Get medical attention if severe.

Battery

Interchange

The sealed battery can fully display its performance only when combined with a proper vehicle electric system. Therefore, replace the sealed battery only on a motorcycle which was originally equipped with the sealed battery.

Be careful, if the sealed battery is installed on a motorcycle which had an ordinary battery as original equipment, the sealed battery's life will be shortened.

Charging Condition Inspection

Battery charging condition can be checked by measuring battery terminal voltage.

- Remove the battery (see Battery Removal).
- Measure the battery terminal voltage.

NOTE

○ Measure with a digital voltmeter [A] which can be read one decimal place voltage.

★ If the reading is below the specified, refreshing charge is required.

Battery Terminal Voltage

Standard: 12.6 V or more

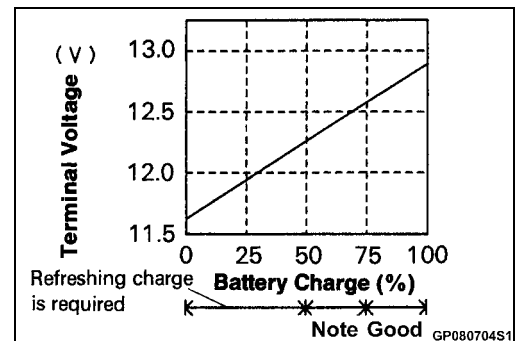
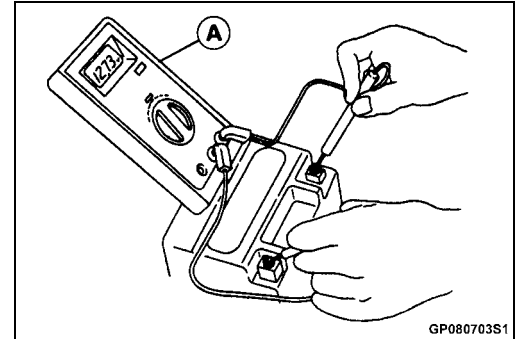

Refreshing Charge

- Remove the battery [A] (see Battery Removal).
- Refresh-charge by following method according to the battery terminal voltage.

⚠ WARNING

This battery is sealed type. Never remove seal cap [B] even at charging. Never add water. Charge with current and time as stated below.

Terminal Voltage: 11.5 ~ less than 12.6 V

Standard Charge: 1.4 A × 5 ~ 10 h (see following chart)

Quick Charge: 6.0 A × 1 h

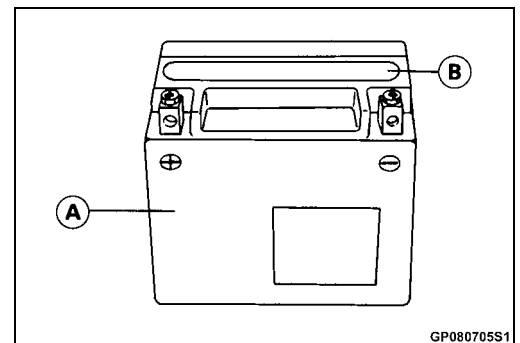

CAUTION

If possible, do not quick charge. If the quick charge is done due to unavoidable circumstances, do standard charge later on.

Terminal Voltage: less than 11.5 V

Charging Method: 1.4 A × 20 h

16-20 ELECTRICAL SYSTEM

Battery

NOTE

○ Increase the charging voltage to a maximum voltage of 25 V if the battery will not accept current initially. Charge for no more than 5 minutes at the increased voltage then check if the battery is drawing current. If the battery will accept current decrease the voltage and charge by the standard charging method described on the battery case. If the battery will not accept current after 5 minutes, replace the battery.

Battery [A]
 Battery Charger [B]
 Standard Value [C]
 Current starts to flow [D].

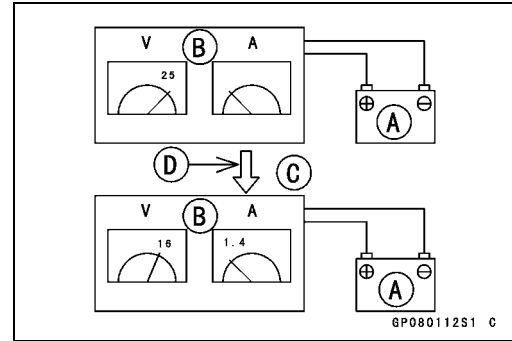

- Determine battery condition after refreshing charge.
- Determine the condition of the battery 30 minutes after completion of the charge by measuring the terminal voltage according to the table below.

Criteria	Judgement
12.6 V or more	Good
12.0 ~ less than 12.6 V	Charge insufficient → Recharge
less than 12.0 V	Unserviceable → Replace

Battery Terminal Voltage (V) [A]
 Charge Time (h) [B]

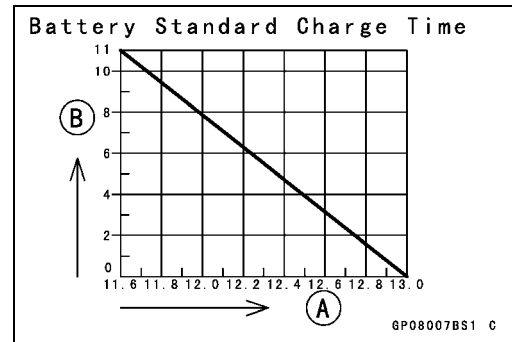

Charging System

Alternator Cover Removal

- Remove:
 - Left Lower Fairing (see Frame chapter)
- Place a suitable container under the alternator cover [A].
- Remove:
 - Alternator Cover Bolts [B]
 - Clamps [C]
 - Alternator Cover
- ★If necessary, remove the stator coil from the alternator cover (see Stator Coil Removal).

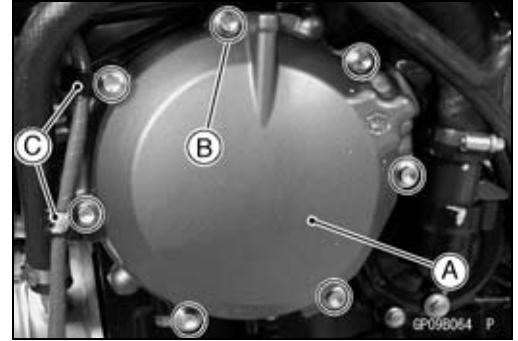

Alternator Cover Installation

- Apply silicone sealant to the alternator lead grommet and crankcase halves mating surface [A] on the front and rear sides of the cover mount.
- Sealant - Kawasaki Bond (Silicone Sealant): 56019-120**
- Check that knock pins [B] are in place on the crankcase.
- Install a new gasket, the alternator cover and clamps.
- Tighten the cover bolts.
- Torque - Alternator Cover Bolts: 15 N·m (1.5 kgf·m, 11 ft·lb)**

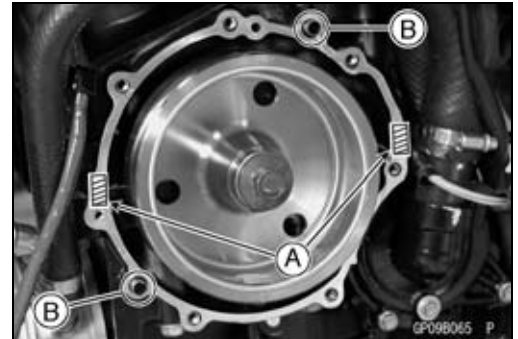

Stator Coil Removal ZX1200-B1/B2

- Remove:
 - Lower Fairing (see Frame chapter)
 - Lift up Fuel Tank (see Fuel System (DFI) chapter)
 - Reserve Tank with Bracket (see Cooling System chapter)
 - Alternator Lead Connectors [A] and [C]
 - Breather Hose Lower End [B]
- Remove the front end of the shift lever rod to loosen the rear lower engine mounting bolt.
- Loosen the upper and lower engine mounting bolts to move the collar [A] on the rear upper engine mounting bolt downward.
- Alternator Lead [B]

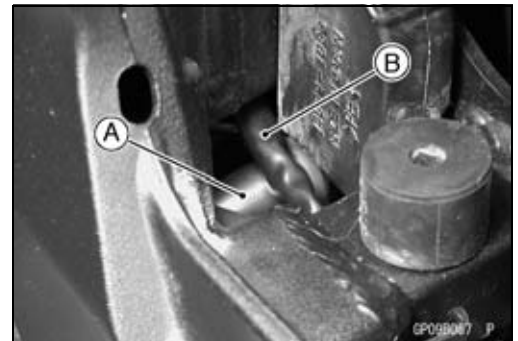
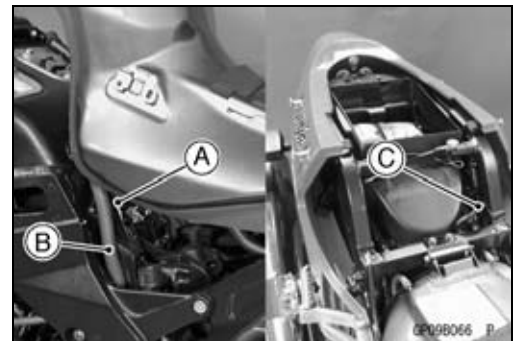

- Remove the alternator leads [A] from the clamps [B].

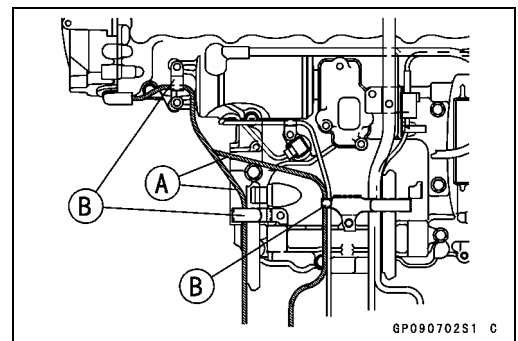

16-22 ELECTRICAL SYSTEM

Charging System

ZX1200-B3

- Remove:
 - Lower Fairing (see Frame chapter)
 - Lift up Fuel Tank (see Fuel System (DFI) chapter)
 - Reserve Tank with Bracket (see Cooling System chapter)
 - Alternator Lead Connectors [A]

- Remove the front end of the shift lever rod to loosen the rear lower engine mounting bolt.
- Loosen the upper and lower engine mounting bolts to move the collar [A] on the rear upper engine mounting bolt downward.
 - Alternator Lead [B]

- Remove:
 - Alternator Cover (see Alternator Cover Removal)
 - Holding Plate Bolts [A] and Plate
 - Alternator Lead Grommet [B]
 - Stator Coil Bolts [C]
 - Stator Coil [D]

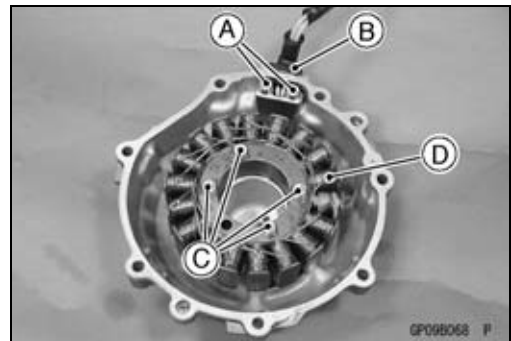
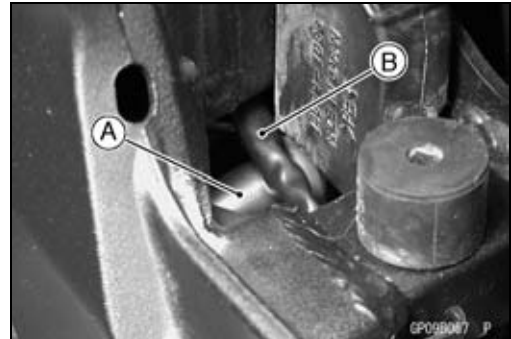
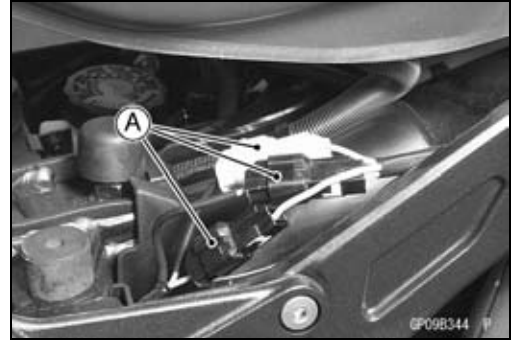

Stator Coil Installation

- Install the stator coil.
 - Torque - Stator Coil Bolts: 22 N·m (2.2 kgf·m, 16 ft·lb)**
- Apply silicone sealant to the circumference of the alternator lead grommet, and fit the grommet into the notch of the cover securely.
 - Sealant - Kawasaki Bond (Silicone Sealant): 56019-120**
- Secure the alternator lead with a holding plate, and apply a non-permanent locking agent to the threads of the plate bolts and tighten them.
 - Torque - Alternator Lead Holding Plate Bolts: 8.5 N·m (0.87 kgf·m, 75 in·lb)**
- Tighten the rear engine mounting bolts and adjusting collars.
 - Torque - Engine Mounting Bolts: 59 N·m (6.0 kgf·m, 44 ft·lb)**
 - Adjusting Collars: 25 N·m (2.5 kgf·m, 18 ft·lb)**
- Install:
 - Alternator Cover (see Alternator Cover Installation)
 - Removed Parts

Charging System

Alternator Rotor Removal

ZX1200-B1/B2

- Remove:
 - Alternator Cover (see Alternator Cover Removal)
- Wipe oil off the outer circumference of the rotor.
- Hold the alternator rotor steady with the flywheel holder [A], and remove the rotor bolt [B].

Special Tool - Flywheel Holder: 57001-1313

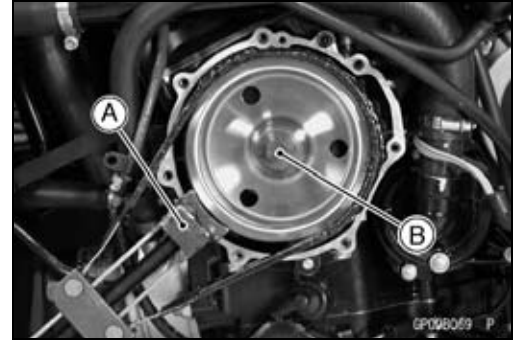

ZX1200-B3

- Remove:
 - Alternator Cover (see Alternator Cover Removal)
- Wipe oil off the outer circumference of the rotor.
- Hold the alternator rotor steady with the rotor holder [A], and remove the rotor bolt [B].

Special Tools - Pulley Holder, Grip [C]: 57001-1591

Rotor Holder: 57001-1592

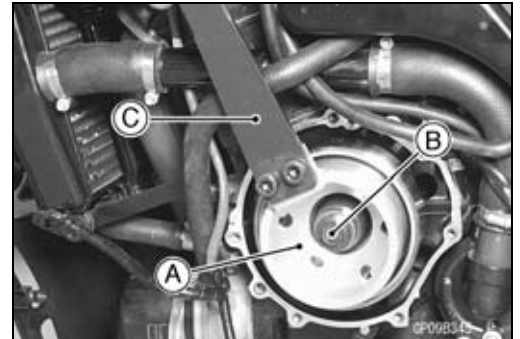

- Remove the alternator rotor [B] from the crankshaft with the rotor puller [A].

Special Tool - Rotor Puller: 57001-1216



Alternator Rotor Installation

- Using a cleaning fluid, clean off any oil or dirt on the following portions and dry them with a clean cloth.
 - Crankshaft Tapered Portion [A]
 - Alternator Rotor Tapered Portion [B]
- Fit the woodruff key [C] securely in the slot in the crankshaft before installing the alternator rotor.
- Align the groove [D] of the rotor with the woodruff key.

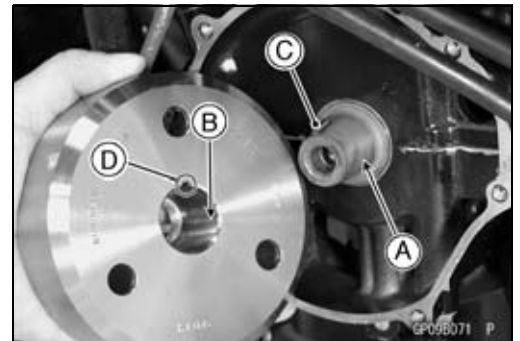

16-24 ELECTRICAL SYSTEM

Charging System

NOTE

- *Confirm the alternator rotor fit or not to the crankshaft before tightening it with specified torque.*
- Install the rotor and tighten it with 70 N·m (7.0 kgf·m, 52 ft·lb) of torque.
- Remove the rotor bolt.
- Check the drawing torque with the part (bolt) of the flywheel puller.

Special Tool - Flywheel Puller Assembly: 57001-1405

- ★ If the rotor is not pulled out with 20 N·m (2.0 kgf·m, 15 ft·lb) of drawing torque, it is installed correctly.
- ★ If the rotor is pulled out with under 20 N·m (2.0 kgf·m, 15 ft·lb) of drawing torque, clean off any oil dirt or flaw of the crankshaft and rotor tapered portion, and dry them with a clean cloth. Then, confirm that it is not pulled out with above torque.
- Tighten the alternator rotor bolt while holding the alternator rotor steady with the flywheel holder.

Special Tool - Flywheel Holder: 57001-1313

Torque - Alternator Rotor Bolt: 110 N·m (11 kgf·m, 81 ft·lb)

- Install the alternator cover (see Alternator Cover Installation).

Alternator Inspection

There are three types of alternator failures: short, open (lead burned out), or loss in rotor magnetism. A short or open in one of the stator coil leads will result in either a low output, or no output at all. A loss in rotor magnetism, which may be caused by dropping or hitting the alternator, by leaving it near an electromagnetic field, or just by aging, will result in low output.

- To check the alternator output voltage, do the following procedures.
- Turn off the ignition switch.
- Remove the seat cover (see Frame chapter).

Charging System

- Disconnect the alternator lead connectors [A].
- Connect the hand tester [B] as shown in the table 1.

Special Tool - Hand Tester: 57001-1394

- Start the engine.
- Run it at the rpm given in the table 1.
- Note the voltage readings (total 3 measurements).

Table 1 Alternator Output Voltage

Tester Range	Connections		Reading @4 000 rpm
	Tester (+) to	Tester (-) to	
250 V AC	One Yellow Lead	Another Yellow Lead	85 ~ 120 V

★ If the output voltage shows the value in the table, the alternator operates properly and the regulator/rectifier is damaged. A much lower reading than that given in the table indicates that the alternator is defective.

- Check the stator coil resistance as follows.
- Stop the engine.
- Connect the hand tester as shown in the table 2.
- Note the readings (total 3 measurement).

Table 2 Stator Coil Resistance

Tester Range	Connections		Reading
	Tester (+) to	Tester (-) to	
$\times 1 \Omega$	One Yellow Lead	Another Yellow Lead	0.3 ~ 0.5 Ω @20°C (68°F)

★ If there is more resistance than shown in the table, or no hand tester reading (infinity) for any two leads, the stator has an open lead and must be replaced. Much less than this resistance means the stator is shorted, and must be replaced.

- Using the highest resistance range of the hand tester, measure the resistance between each of the Yellow leads and chassis ground.

★ Any hand tester reading less than infinity (∞) indicates a short, necessitating stator replacement.

★ If the stator coils have normal resistance, but the voltage check showed the alternator to be defective; then the rotor magnets have probably weakened, and the rotor must be replaced.

Regulator/Rectifier Inspection

ZX1200-B1/B2

- Remove:
 - Seat Cover (see Frame chapter)
 - Connectors [A] (disconnect)
 - Bolts [B]
 - Regulator/Rectifier [C]

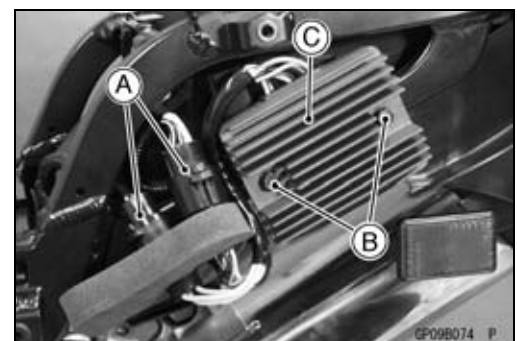
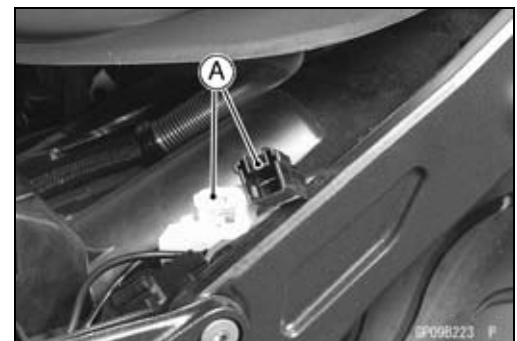
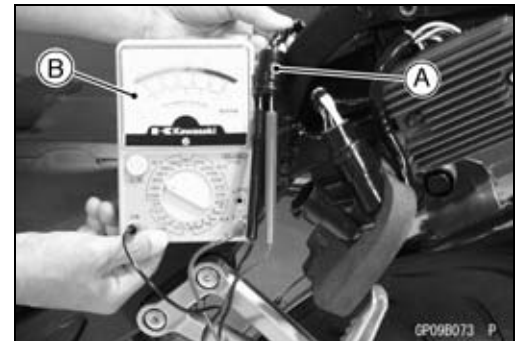

16-26 ELECTRICAL SYSTEM

Charging System

ZX1200-B3

- Remove:
 - Seat Cover (see Frame chapter)
 - Connector [A] (disconnect)

- Remove:
 - Lift up Fuel Tank (see Fuel System (DFI) chapter)
 - Connectors [A] (disconnect)

- Remove:
 - Bolts [A]
 - Regulator/rectifier [B]

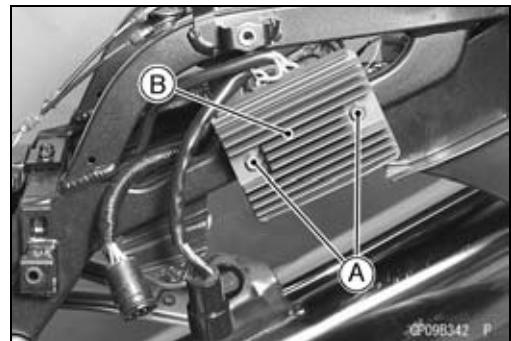
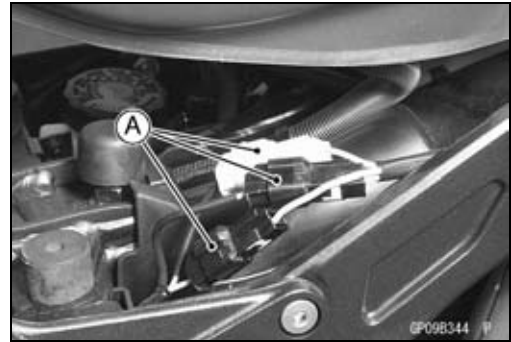

Rectifier Circuit Check

- Check conductivity of the following pair of terminals.

Rectifier Circuit Inspection

Tester connection	W/R1-Y1, W/R1-Y2, W/R1-Y3
	W/R2-Y1, W/R2-Y2, W/R2-Y3
	BK1-Y1, BK1-Y2, BK1-Y3
	BK2-Y1, BK2-Y2, BK2-Y3

★The resistance should be low in one direction and more than ten times as much in the other direction. If any two leads are low or high in both directions, the rectifier is defective and must be replaced.

NOTE

○The actual meter reading varies with the meter used and the individual rectifier, but, generally speaking the lower reading should be from zero to one half the scale.

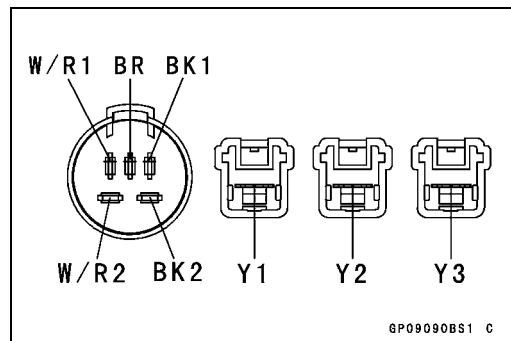
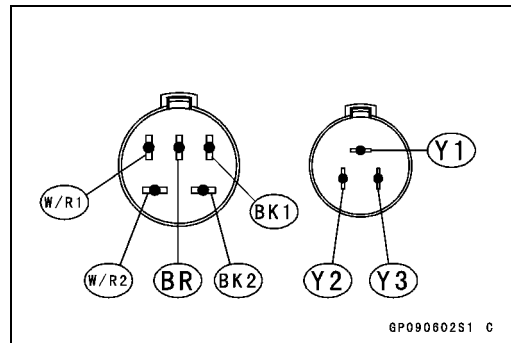

Charging System

Regulator Circuit Check

To test the regulator out of circuit, use three 12 V batteries and a test light (12 V 3 ~ 6 W bulb in a socket with leads).

CAUTION

The test light works as an indicator and also a current limiter to protect the regulator/rectifier from excessive current. Do not use an ammeter instead of a test light.

- Check to be sure the rectifier circuit is normal before continuing.

Regulator Circuit Test: 1st Step

- Connect the test light and the 12 V battery to the regulator/rectifier as shown.
- Check Y1, Y2, and Y3 terminal respectively.
- ★ If the test light turns on, the regulator/rectifier is defective. Replace it.
- ★ If the test light does not turn on, continue the test.

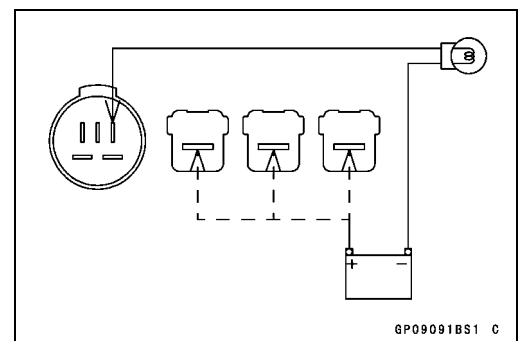
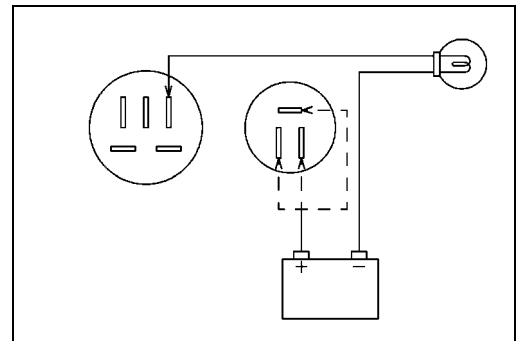

Regulator Circuit Test: 2nd Step

- Connect the test light and the 12 V battery in the same manner as specified in the "Regulator Circuit Test-1st Step".
- Apply 12 V to the BR (voltage monitoring) terminal.
- Check Y1, Y2, and Y3 terminal respectively.
- ★ If the test light turns on, the regulator/rectifier is defective. Replace it.
- ★ If the test light does not turn on, continue the test.

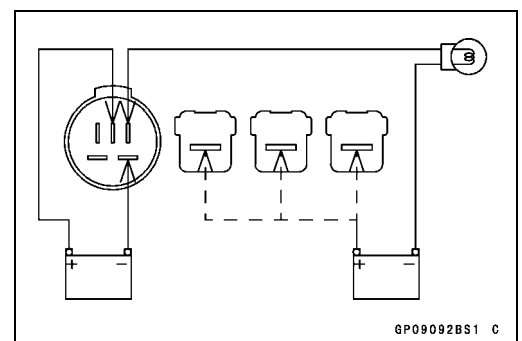
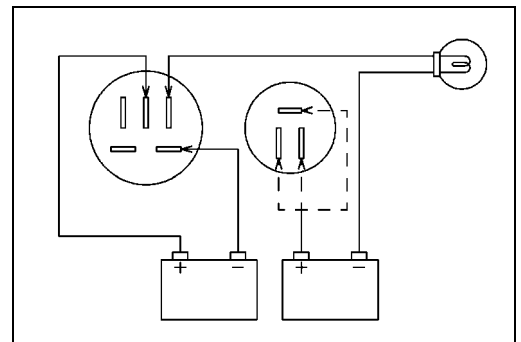

16-28 ELECTRICAL SYSTEM

Charging System

Regulator Circuit Test: 3rd Step

- Connect the test light and the 12 V battery in the same manner as specified in the "Regulator Circuit Test-1st Step".
- Momentarily apply 24 V to the BR terminal by adding a 12 V battery.
- Check Y1, Y2, and Y3 terminals respectively.

CAUTION

Do not apply more than 24 V to the regulator/rectifier and do not leave the 24 V applied for more than a few seconds, or the unit will be damaged.

- ★ If the test light did not light when the 24 V was applied momentarily to the BR terminal, the regulator/rectifier is defective. Replace it.
- ★ If the regulator/rectifier passes all of the tests described, it may still be defective. If the charging system still does not work properly after checking all of the components and the battery, test the regulator/rectifier by replacing it with a known good unit.

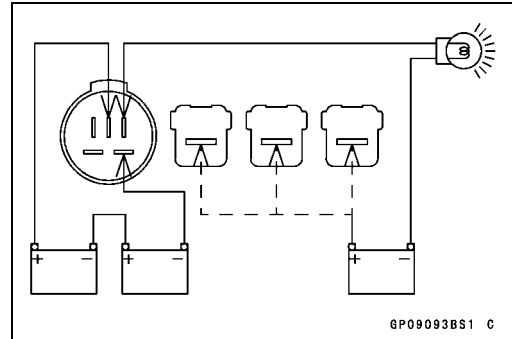
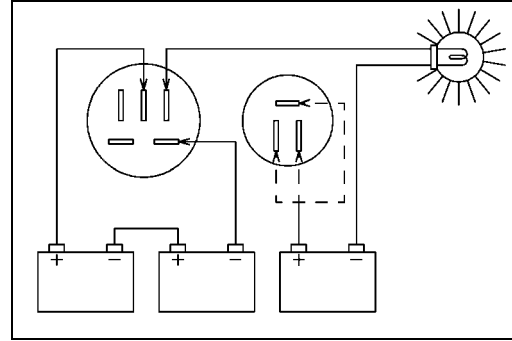

Regulator/Rectifier Output Voltage Inspection ZX1200-B1/B2

- Check the battery condition (see Battery section).
- Remove the seat cover (see Frame chapter).
- Warm up the engine to obtain actual alternator operating conditions.
- Turn off the ignition switch, and connect the lead wire -voltage regulator adapter [A] between the regulator/rectifier lead 5 pins connectors [B] as shown in the figure.
- Connect the hand tester to the connector [C] of the adapter as shown in the table.
- Start the engine, and note the voltage readings at various engine speeds with the headlight turned on and then turned off. (To turn off the headlight of U.S.A., Canadian, Australian and Malaysian models, disconnect the headlight connector in the upper fairing.) The readings should show nearly battery voltage when the engine speed is low, and as the engine speed rises, the readings should also rise. But they must be kept under the specified voltage.

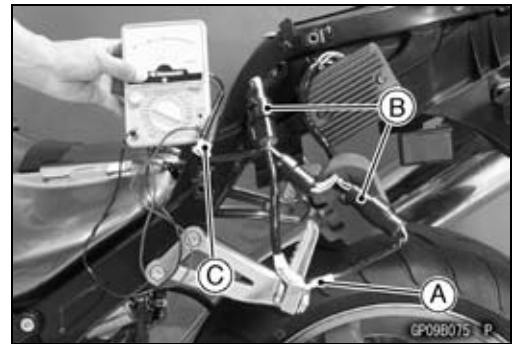

Regulator/Rectifier Output Voltage

Tester Range	Connections		Reading
	Tester (+) to	Tester (-) to	
25 V DC	White/Red	Black	14.2 ~15.2 V

Special Tools - Hand Tester: 57001-1394

**Lead Wire - Voltage Regulator Adapter:
57001-1448**

Charging System

ZX1200-B3

- Check the battery condition (see Battery section).
- Remove the seat cover (see Frame chapter).
- Warm up the engine to obtain actual alternator operating conditions.
- Check that the ignition switch is turned off, and connect the hand tester as shown in the table.

Special Tool - Hand Tester: 57001-1394

- Start the engine, and note the voltage readings at various engine speeds with the headlight turned on and then turned off. (To turn off the headlight of U.S.A., Canadian, Australian and Malaysian models, disconnect the headlight connector in the upper fairing.) The readings should show nearly battery voltage when the engine speed is low, and, as the engine speed rises, the readings should also rise. But they must be kept under the specified voltage.

Regulator/Rectifier Output Voltage

Tester Range	Connections		Reading
	Tester (+) to	Tester (-) to	
25 V DC	Battery (+)	Battery (-)	14.2 ~ 15.2 V

- Turn off the ignition switch to stop the engine, and disconnect the hand tester.
- ★ If the regulator/rectifier output voltage is kept between the values given in the table, the charging system is considered to be working normally.
- ★ If the output voltage is much higher than the values specified in the table, the regulator/rectifier is defective or the regulator/rectifier leads are loose or open.
- ★ If the battery voltage does not rise as the engine speed increases, then the regulator/rectifier is defective or the alternator output is insufficient for the loads. Check the alternator and regulator/rectifier to determine which part is defective.

16-30 ELECTRICAL SYSTEM

Charging System

Charging System Circuit

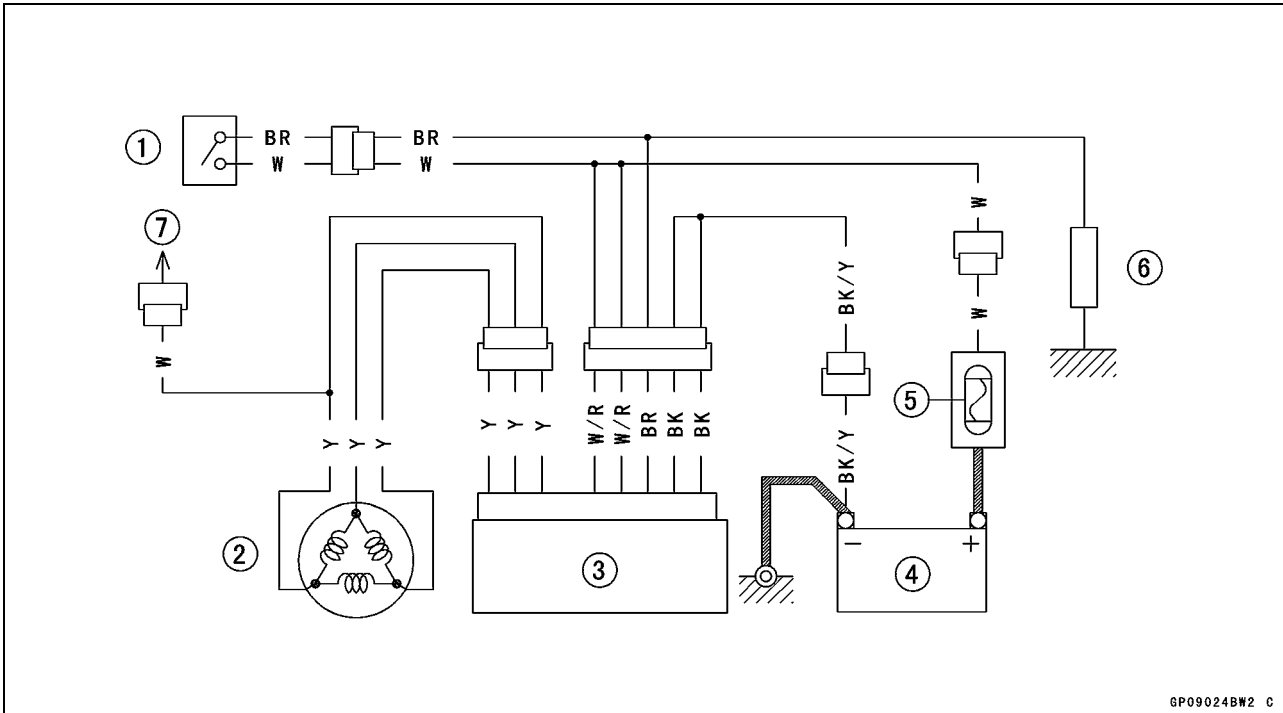

GP09024BW2 C

1. Ignition Switch
2. Alternator
3. Regulator/Rectifier
4. Battery
5. Main Fuse 30 A
6. Load
7. Headlight Relay in Junction Box (US, CA, AU, and MY models)

Ignition System

⚠ WARNING

The ignition system produces extremely high voltage. Do not touch the spark plugs or stick coils while the engine is running, or you could receive a severe electrical shock.

CAUTION

Do not disconnect the battery cables or any other electrical connections when the ignition switch is on, or while the engine is running. This is to prevent ECU (Electronic Control Unit) damage.

Do not install the battery backwards. The negative side is grounded. This is to prevent damage to the diodes and ECU.

Crankshaft Sensor Removal

- Remove:
 - Left Lower Fairing (see Frame chapter)
 - Crankshaft Sensor Lead Connector [A]
 - Hot Wind Cover (see Frame chapter)
- Pull the connector forward.

- Remove:
 - Crankshaft Sensor Cover Bolts [A] with Clamp [B]
 - Crankshaft Sensor Cover [C]

- Remove:
 - Crankshaft Sensor Bolts [A]
 - Crankshaft Sensor [B]

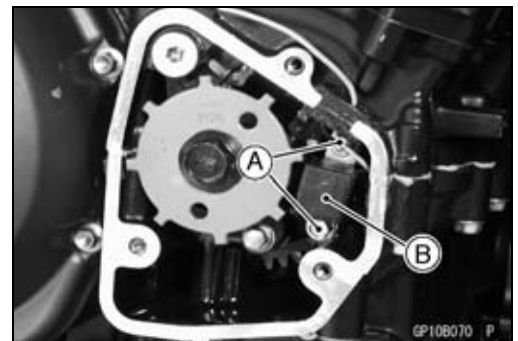
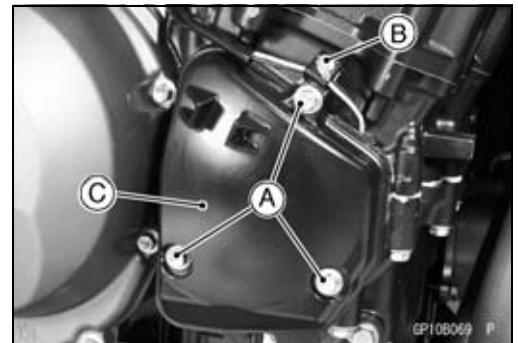
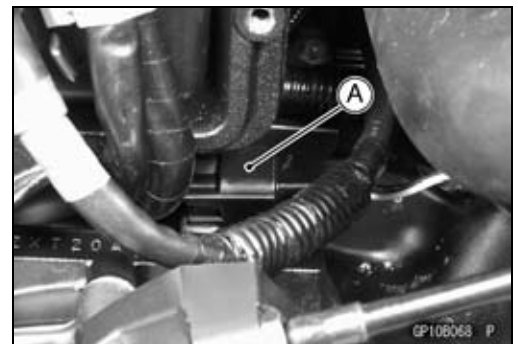

16-32 ELECTRICAL SYSTEM

Ignition System

Crankshaft Sensor Installation

- Route the crankshaft sensor lead correctly (see Cable, Wire, and Hose Routing in General Information chapter).
- Install the crankshaft sensor and tighten the crankshaft sensor bolts.

Torque - Crankshaft Sensor Bolts: 6.0 N·m (0.60 kgf·m, 53 in·lb)

- Apply silicone sealant [A] to the crankshaft sensor lead grommet and crankcase halves mating surface on the front and rear sides of the crankshaft sensor cover mount.

Sealant - Kawasaki Bond (Silicone Sealant): 56019-120

- Apply a non-permanent locking agent to the threads of the crankshaft sensor cover bolts and tighten them.

Torque - Crankshaft Sensor Cover Bolts: 15 N·m (1.5 kgf·m, 11 ft·lb)

- Install the other removed parts.



Crankshaft Sensor Inspection

- Remove:
 - Lower Fairing (see Frame chapter)
 - Crankshaft Sensor Lead Connector [A]
- Set the hand tester [B] to the $\times 10 \Omega$ range and connect it to the yellow and black leads in the connector.

Special Tool - Hand Tester: 57001-1394

- ★ If there is more resistance than the specified value, the sensor coil has an open lead and must be replaced. Much less than this resistance means the sensor coil is shorted, and must be replaced.

Crankshaft Sensor Resistance: 423 ~ 517 Ω

- Using the highest resistance range of the tester, measure the resistance between the crankshaft sensor leads and chassis ground.
- ★ Any tester reading less than infinity (∞) indicates a short, necessitating replacement of the crankshaft sensor assembly.

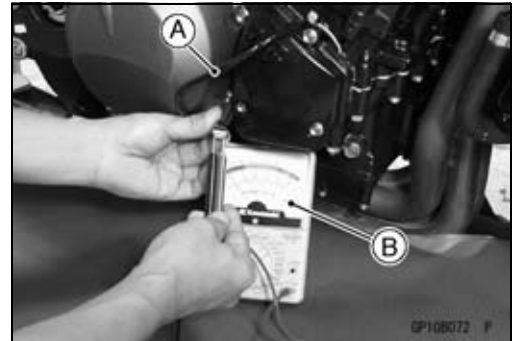

Crankshaft Sensor Peak Voltage Inspection

- Remove:
 - Lower Fairing (see Frame chapter)
 - Crankshaft Sensor Lead Connector [A]
- Set the hand tester [B] to the 10 V DC range.
- Connect the peak voltage adapter [C] to the hand tester and crankshaft sensor leads in the connector.

Special Tool - Hand Tester: 57001-1394

Recommended Tool - Peak Voltage Adapter
Type: KEK-54-9-B
Brand: KOWA SEIKI

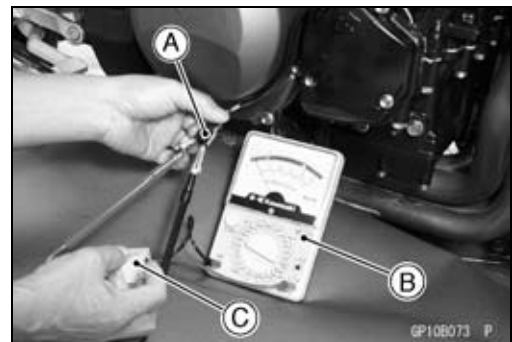

Connections

Crankshaft Sensor Lead	Adapter	Hand Tester
Yellow	← Red →	(+)
Black	← Black →	(-)

Ignition System

- Turn the ignition switch and engine stop switch on.
- Pushing the starter button, turn the engine 4 ~ 5 seconds with the transmission gear in neutral to measure the crankshaft sensor peak voltage.
- Repeat the measurement 5 or more times.

Crankshaft Sensor Peak Voltage

Standard: 3.6 V or more

- ★ If the peak voltage is lower than the standard, inspect the crankshaft sensor.

Camshaft Position Sensor Removal

- Remove:
 - Left Lower Inner Cover (see Frame chapter)
 - Air Inlet Duct [B] (see Fuel System (DFI) chapter)
 - Camshaft Position Sensor Lead Connector [A] (disconnect)
 - Left Side Rivet Screw [D] of Baffle Plate [C]
 - Baffle Plate [E]
 - Clamp [F] (flatten)
- Lift the left side of the baffle plate and take out the camshaft position sensor lead connector.
- Remove:
 - Camshaft Position Sensor Bolt [A]
 - Camshaft Position Sensor [B]

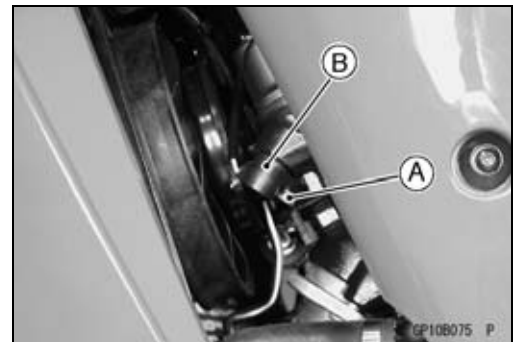
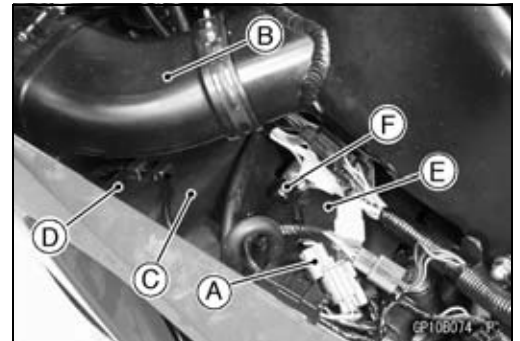

Camshaft Position Sensor Installation

- Apply grease or engine oil to the O-ring on the camshaft position sensor.
- Tighten:
 - Torque - Camshaft Position Sensor Bolt: 12 N·m (1.2 kgf·m, 106 in·lb)**

16-34 ELECTRICAL SYSTEM

Ignition System

Camshaft Position Sensor Inspection

- Remove:
 - Left Lower Inner Cover (see Frame chapter)
 - Camshaft Position Sensor Lead Connector [A] (disconnect)
- Set the hand tester to the $\times 10 \Omega$ range and connect it to the yellow and black leads in the connector.

Special Tool - Hand Tester: 57001-1394

- ★ If there is more resistance than the specified value, the sensor coil has an open lead and must be replaced. Much less than this resistance means the sensor coil is shorted, and must be replaced.

Camshaft Position Sensor Resistance: 400 ~ 460 Ω

- Using the highest resistance range of the tester, measure the resistance between the camshaft position sensor leads and chassis ground.
- ★ Any tester reading less than infinity (∞) indicates a short, necessitating replacement of the camshaft position sensor.

Camshaft Position Sensor Peak Voltage Inspection

- Remove:
 - Left Lower Inner Cover (see Frame chapter)
 - Camshaft Position Sensor Lead Connector [A]
- Set the hand tester [B] to the 10 V DC range.
- Connect the peak voltage adapter [C] to the hand tester and camshaft position sensor leads in the connector.

Special Tool - Hand Tester: 57001-1394

Recommended Tool - Peak Voltage Adapter
Type: KEK-54-9-B
Brand: KOWA SEIKI

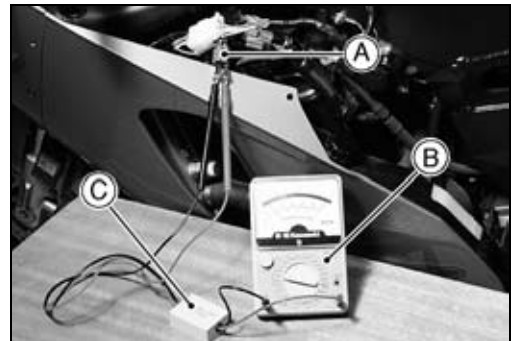
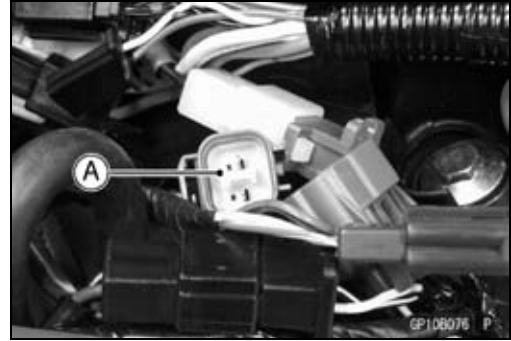

Connections

Camshaft Position Sensor Lead		Adapter		Hand Tester
Black	←	Red	→	(+)
Yellow	←	Black	→	(-)

- Turn the ignition switch and engine stop switch on.
- Pushing the starter button, turn the engine 4 ~ 5 seconds with the transmission gear in neutral to measure the camshaft position sensor peak voltage.
- Repeat the measurement 5 or more times.

Camshaft Position Sensor Peak Voltage

Standard: 0.2 V or more

- ★ If the peak voltage is lower than the standard, inspect the camshaft position sensor.

Ignition System

Stick Coil (Ignition Coil together with Spark Plug Cap) Removal

- Remove:
 - Inner Lower Covers (see Frame chapter)
 - Baffle Plate
- Disconnect the stick coil connectors [B].
- Pull the stick coils [A] off the spark plugs.

CAUTION

Do not pry the connector part of the coil while removing the coil.

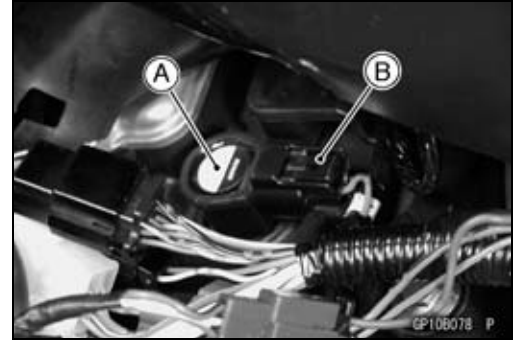

Stick Coil (Ignition Coil together with Spark Plug Cap) Installation

- Install the coil with following steps.
 - Connect the connector.
 - Insert the coil as shown being careful of the coil head direction.
 - Be sure the stick coils are installed securely by pulling up it lightly.

CAUTION

Do not tap the coil head while installing the coil.

Stick Coil (Ignition Coil together with Spark Plug Cap) Inspection

- Remove the stick coils (see Stick Coil Removal).
- Measure the primary winding resistance [A] as follows.
 - Connect the hand tester between the coil terminals.
 - Set the tester to the $\times 1 \Omega$ range, and read the tester.
- Measure the secondary winding resistance [B] as follows.
 - Connect the tester between the plug terminal and (-) coil terminal.
 - Set the tester to the $\times 1 \text{ k}\Omega$ range and read the tester.

Stick Coil Winding Resistance

Primary Windings:

ZX1200-B1/B2	0.85 ~ 1.15 Ω
ZX1200-B3	1.04 ~ 1.56 Ω

Secondary Windings:

ZX1200-B1/B2	9.2 ~ 13.8 $\text{k}\Omega$
ZX1200-B3	10.8 ~ 16.2 $\text{k}\Omega$

★If the tester does not read as specified, replace the coil.

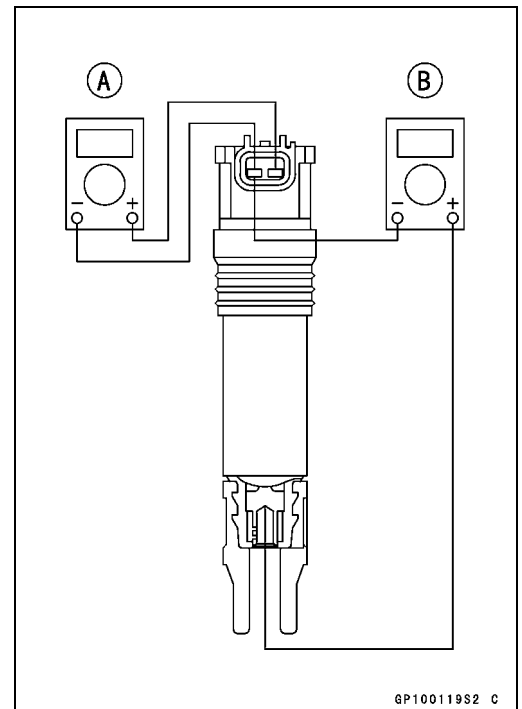

GP100119S2 C

16-36 ELECTRICAL SYSTEM

Ignition System

Stick Coil Primary Peak Voltage Inspection

NOTE

○ Be sure the battery is fully charged.

- Remove the stick coils (see Stick Coil Removal), but do not remove the spark plugs.
- Measure the primary peak voltage as follows.
- Disconnect the stick coil connector, and connect the lead wire-peak voltage adapter [A] between the stick coil connector and stick coil.
- Connect a commercially peak voltage adapter [B] between the lead wire-peak voltage adapter and the hand tester [C] which is set to the 250 V DC range.
- Install the new spark plug [D] into each stick coil [E], and ground them onto the engine.
 - ECU [F]
 - Battery [G]

Recommended Tool - Peak Voltage Adapter

Type: KEK-54-9-B

Brand: KOWA SEIKI

Special Tools - Hand Tester: 57001-1394

Lead Wire-Peak Voltage Adapter: 57001-1449

Primary Lead Connection

Adapter (R, +) to lead wire-peak voltage adapter (W)

Adapter (BK, -) to lead wire-peak voltage adapter (R)

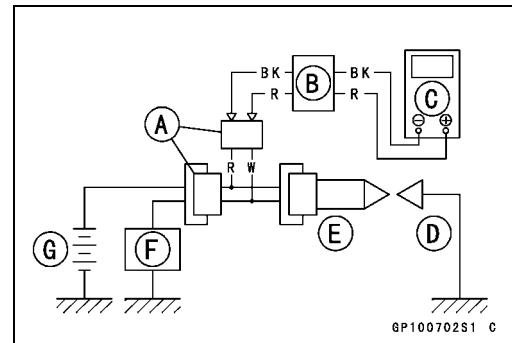
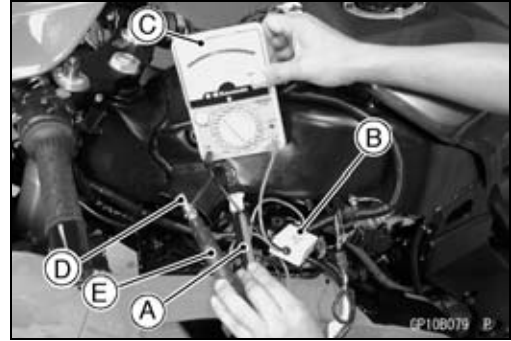

⚠ WARNING

To avoid extremely high voltage shocks, do not touch the spark plugs or tester connections.

- Turn the ignition switch and the engine stop switch ON.
- Pushing the starter button, turn the engine 4 ~ 5 seconds with the transmission in neutral to measure the primary peak voltage.
- Repeat the measurements 5 times for one stick coil.

Stick Coil Primary Peak Voltage

Standard:

ZX1200-B1/B2: 80 V or more

ZX1200-B3: 88 V or more

- Repeat the test for the other stick coil.
- ★ If the reading is less than the specified value, check the following.
 - Stick Coils (see Stick Coil Inspection)
 - Crankshaft Sensor (see Crankshaft Sensor Inspection)
- ★ If the stick coils and crankshaft sensor are normal, check the ECU (see Fuel System (DFI) chapter).

Spark Plug Removal

- Remove:
 - Stick Coils (see Stick Coil Removal)
- Remove the spark plugs with the 16 mm plug wrench.
 - Owner's Tool - Spark Plug Wrench, 16 mm: 92110-1132

Ignition System

Spark Plug Installation

- Insert the spark plug vertically into the plug hole with the plug [A] installed in the plug wrench [B].

Owner's Tool - Spark Plug Wrench, 16 mm: 92110-1132

- Tighten the plugs.
- Torque - Spark Plugs: 13 N·m (1.3 kgf·m, 115 in·lb)**
- Fit the stick coils securely.

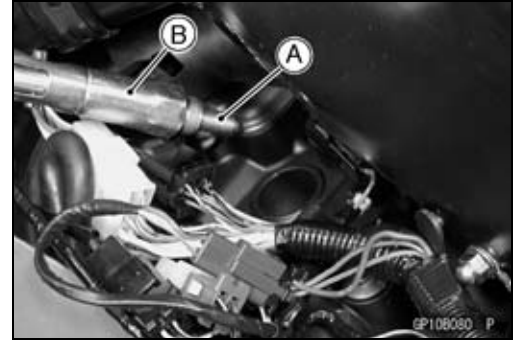

Spark Plug Cleaning and Inspection

- Refer to the Spark Plug Cleaning/Inspection in the Periodic Maintenance chapter.

Spark Plug Gap Inspection

- Refer to the Spark Plug Cleaning/Inspection in the Periodic Maintenance chapter.

Interlock Operation Inspection

- Remove:
 - Fuel Tank Cover (see Fuel System (DFI) chapter)
- Do not disconnect the connectors.

1st Check

- Measure the terminal voltage of the G/BK lead in the junction box connector [A] in accordance with the following procedure.
- Set the tester [B] to the 10 V DC range, connect it to the G/BK lead and frame ground [C].



Connection

Tester (+) Terminal → G/BK Lead Terminal

Tester (-) Terminal → Frame Ground

Condition

Transmission Gear → 1st Position

Clutch Lever → Release

Side Stand → Down

- Turn the ignition switch on.
- Read the voltage.

Interlock Operation Voltage

Standard: 4 V or more

- ★ If the voltage is lower than the standard, inspect the side stand switch, starter lockout switch, gear position switch and junction box. And their parts are normality, replace the ECU.
- ★ If the voltage is standard, push the starter button to check as follows.
- If the starter motor does not turn, the ECU is good, and check the starter system circuit.
- If the starter motor turned, ECU is defective. Replace the ECU.

16-38 ELECTRICAL SYSTEM

Ignition System

2nd Check

Raise the rear wheel off the ground with a stand.

- Inspect the engine for its secure stop after the following operations are completed.
- Run the engine to the following conditions.

Condition

Transmission Gear → 1st Position

Clutch Lever → Pull in

Side Stand → Up or Down

- Gradually release the clutch lever, then the engine will stop.
- Run the engine to the following conditions.

Condition

Transmission Gear → 1st Position

Clutch Lever → Release

Side Stand → Up

- Set the side stand on the ground, then the engine will stop.
- ★ If whichever may not be stopped, inspect the gear position switch, starter lockout switch, side stand switch and junction box.
- ★ If their parts are normality, replace the ECU.

IC Igniter Inspection

○ The IC igniter is built in the ECU [A].

- Refer to the Interlock Operation Inspection, Ignition System Troubleshooting chart and Fuel System (DFI) chapter for ECU Inspection.

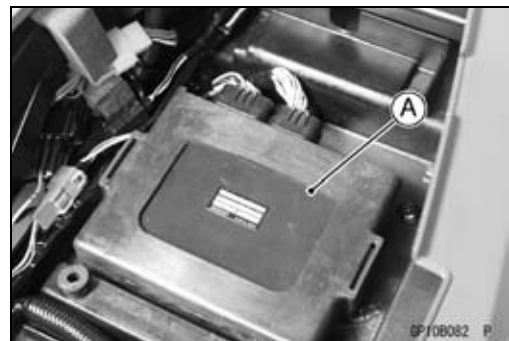

Ignition System

Ignition System Inspection

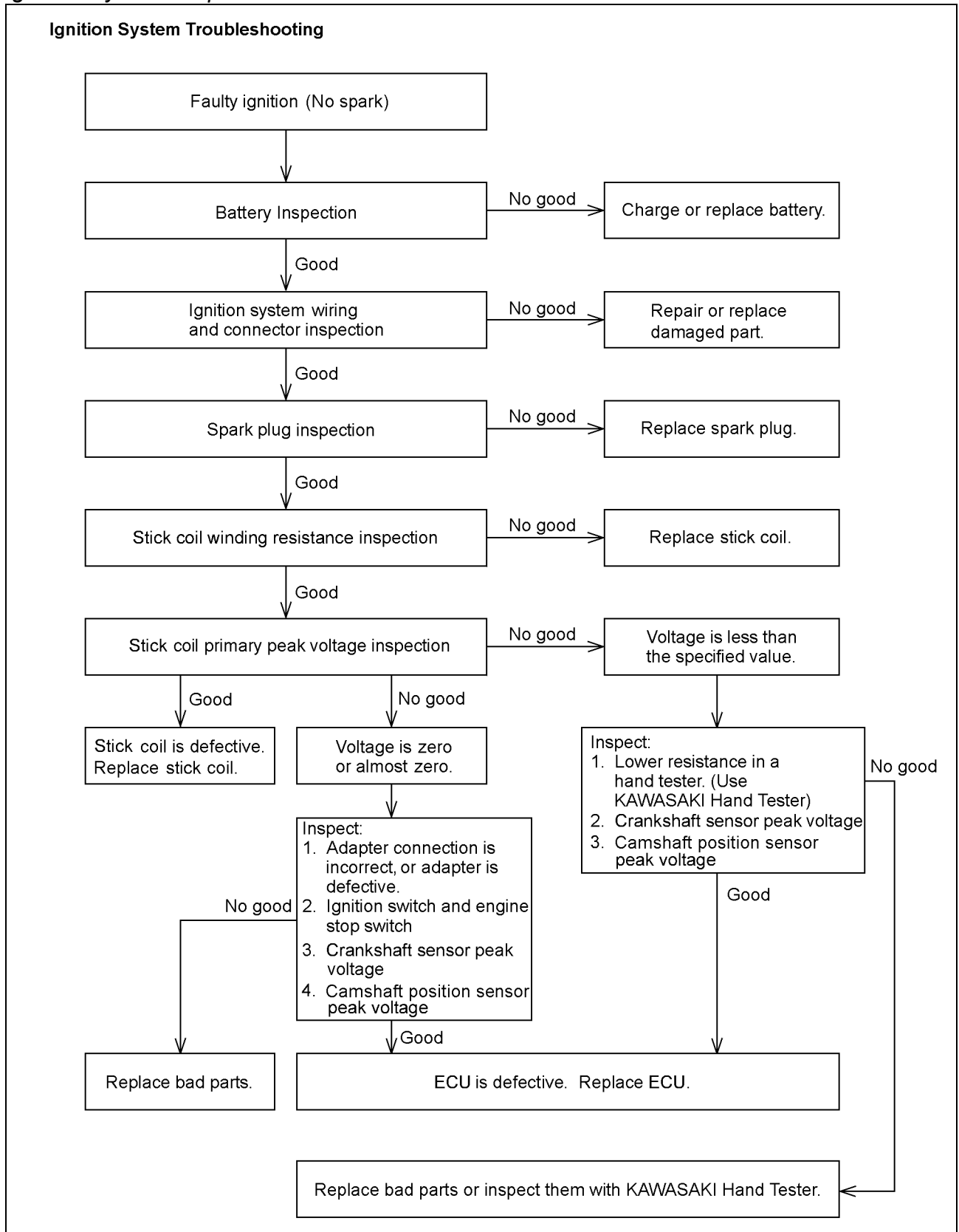

16-40 ELECTRICAL SYSTEM

Ignition System

Ignition System Circuit ZX1200-B1/B2

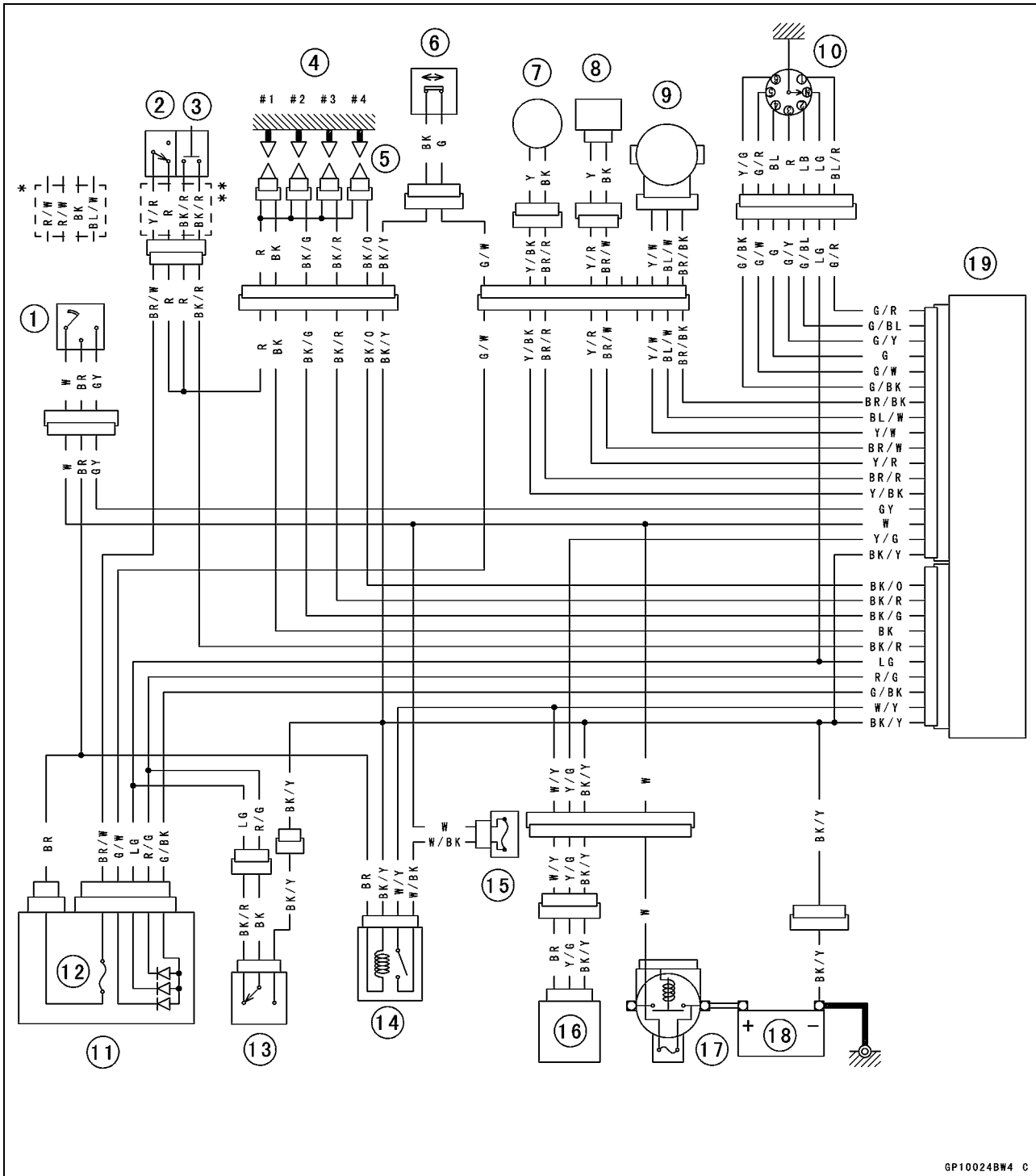

GP10024BW4 C

- | | |
|---|--|
| <ol style="list-style-type: none"> 1. Ignition Switch 2. Engine Stop Switch 3. Starter Button 4. Spark Plugs 5. Stick Coils 6. Side Stand Switch 7. Crankshaft Sensor 8. Camshaft Position Sensor 9. Throttle Sensor 10. Gear Position Switch 11. Junction Box 12. Ignition Fuse 10 A | <ol style="list-style-type: none"> 13. Starter Lockout Switch 14. ECU Main Relay 15. ECU Fuse 15 A 16. Vehicle-down Sensor 17. Main Fuse 30 A 18. Battery 19. ECU (Electronic Control Unit) <p>*: U.S.A., Canadian, Australian and Malaysian Models
 **: Other than U.S.A., Canadian, Australian and Malaysian Models</p> |
|---|--|

Ignition System

ZX1200-B3

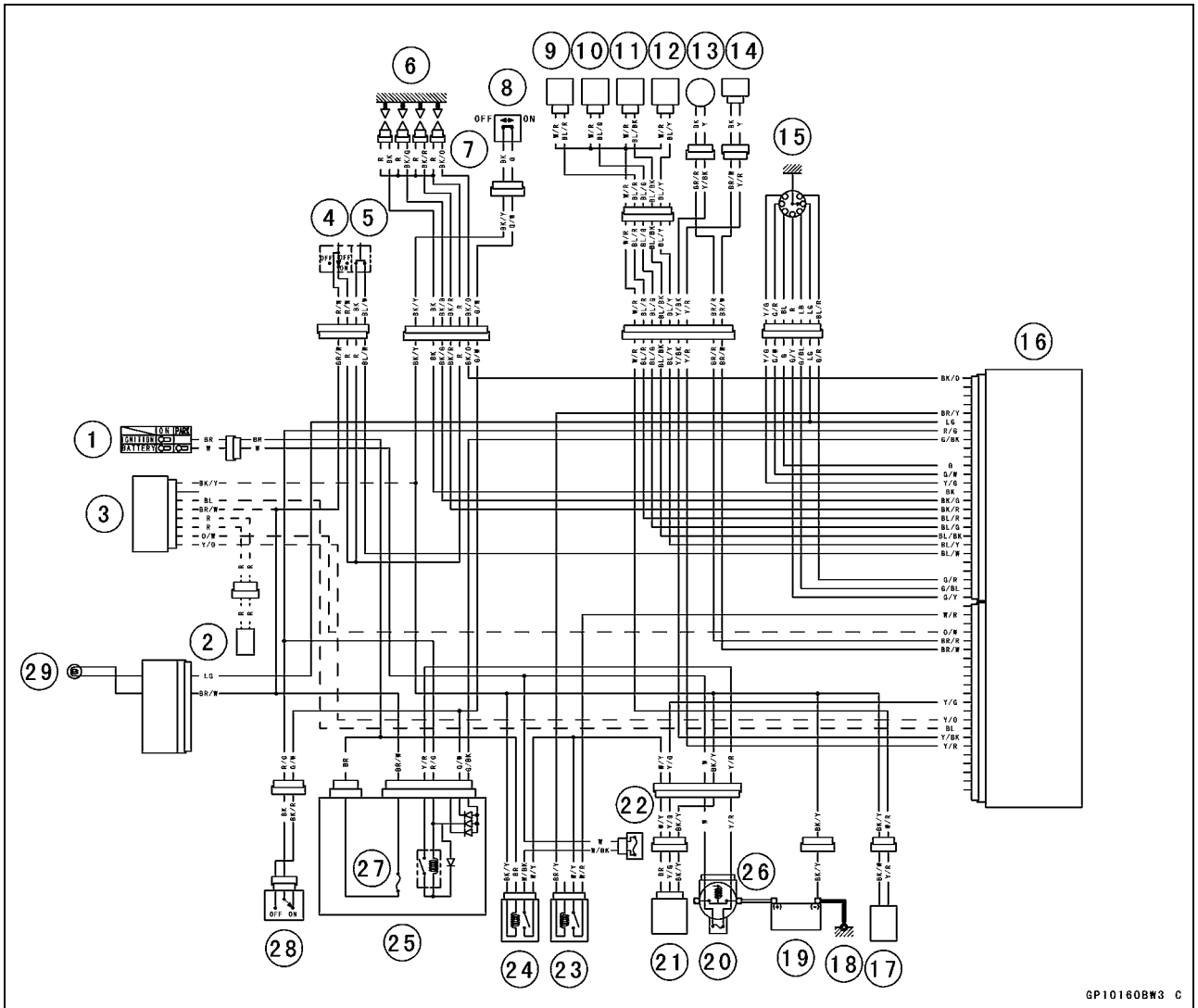

GP10160BW3 C

- | | |
|--|--|
| <ol style="list-style-type: none"> 1. Ignition Switch 2. Immobilizer Antenna 3. Immobilizer Amplifier 4. Engine Stop Switch 5. Starter Button 6. Spark Plugs 7. Stick Coils 8. Side Stand Switch 9. Fuel Injector #1 10. Fuel Injector #2 11. Fuel Injector #3 12. Fuel Injector #4 13. Crankshaft Sensor 14. Camshaft Position Sensor 15. Gear Position Switch | <ol style="list-style-type: none"> 16. ECU (Electric Control Unit) 17. Fuel Pump 18. Engine Ground 19. Battery 20. Main Fuse 30 A 21. Vehicle-down Sensor 22. ECU Fuse 15 A 23. Fuel Pump Relay 24. ECU Main Relay 25. Junction Box 26. Starter Relay 27. Ignition Fuse 10 A 28. Starter Lockout Switch 29. Meter Assembly |
|--|--|

16-42 ELECTRICAL SYSTEM

Electric Starter System

Starter Motor Removal

- Remove:
 - Battery Compartment Cover (see Battery Removal)
 - Terminal Nut [A]
 - Starter Motor Cable [B]

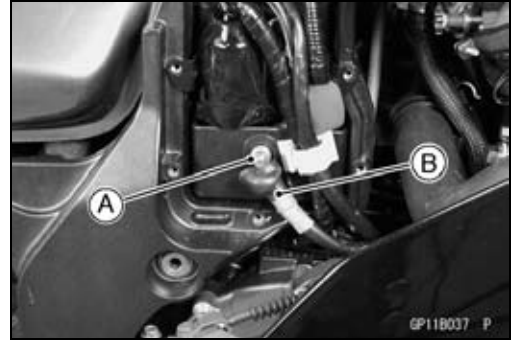

- Remove:
 - Lower Fairing (see Frame chapter)
 - Coolant Reserve Tank
 - Starter Motor Mounting Bolts [A]

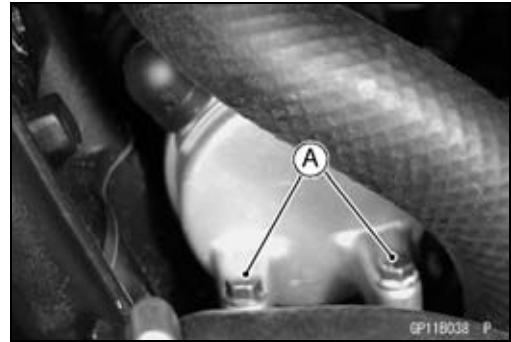

- Pull out the starter motor [A].
- Remove:
 - Terminal Nut [B]
 - Starter Motor Cable [C]

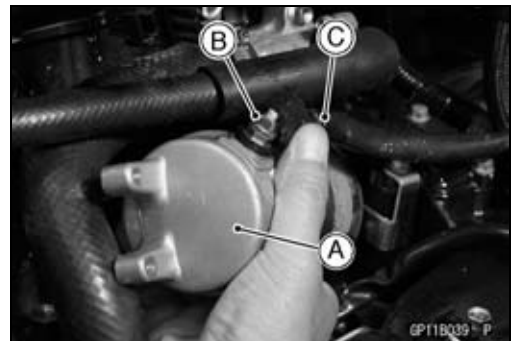

Starter Motor Installation

CAUTION

Do not tap the starter motor shaft or body. Tapping the shaft or body could damage the motor.

- When installing the starter motor, clean the starter motor legs [A] and crankcase [B] where the starter motor is grounded.
- Apply small amount of engine oil or grease to the O-ring [A].
- Install the starter motor and tighten the mounting bolts.
Torque - Starter Motor Mounting Bolts: 12 N·m (1.2 kgf·m, 106 in·lb)

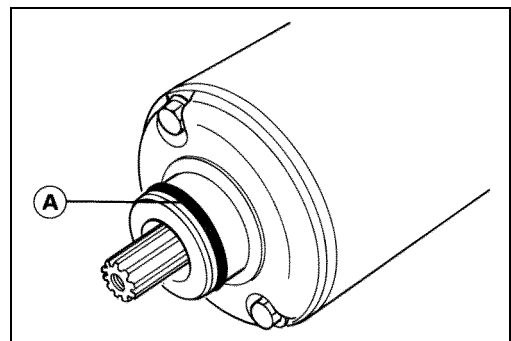
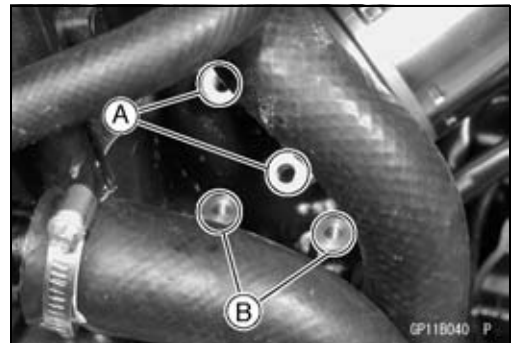

Electric Starter System

Starter Motor Disassembly

- Take off the starter motor through bolts [A] and remove both end covers [B] and pull the armature out of the yoke [C].

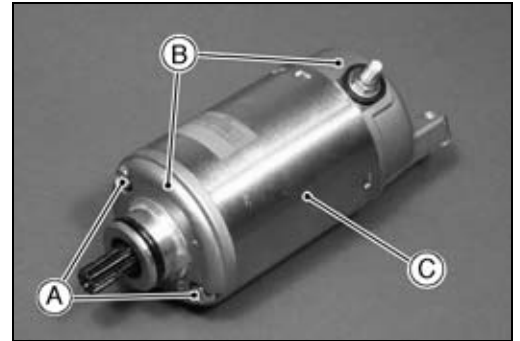

- The brush plate [A] and brushes come off with the left-hand end cover [B].



- Remove the terminal locknut [A] and terminal bolt [B], and then remove the brush with the brush plate [C] from the left-hand end cover.

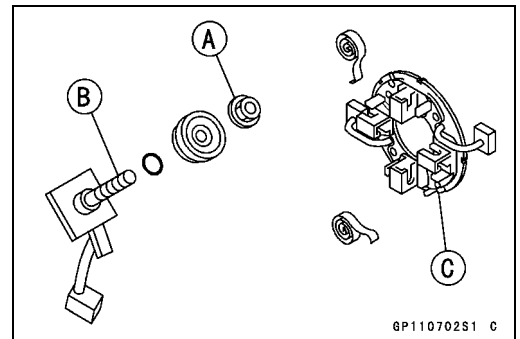

Starter Motor Assembly

- Install the brush plate and brushes [A], and then put the armature [B] among the brushes.

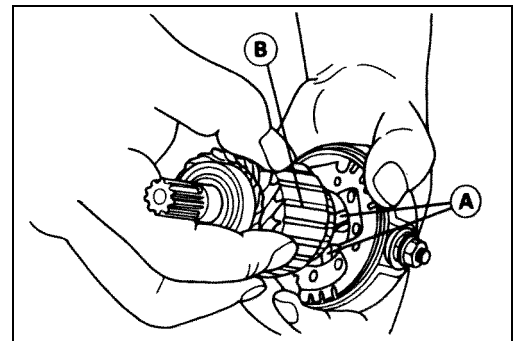

- Install the O-rings [A] as shown.

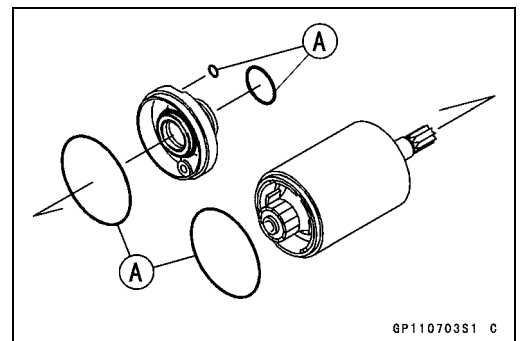

16-44 ELECTRICAL SYSTEM

Electric Starter System

- Align the notch [A] in the brush plate with the end cover notch [B] and the mark [C] on the yoke.

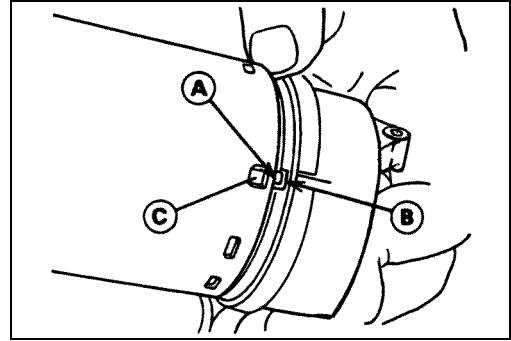

- Align the line [A] marked on the yoke with the through bolt hole [B].

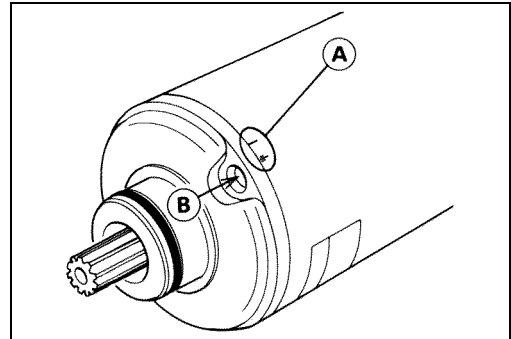

Brush Inspection

- Measure the length [A] of each brush [B].
- ★ If any is worn down to the service limit, replace the carbon brush holder assembly [C] and the terminal bolt assembly [D].

Starter Motor Brush Length

Standard: 12 mm (0.47 in.)

Service Limit: 8.5 mm (0.33 in.)

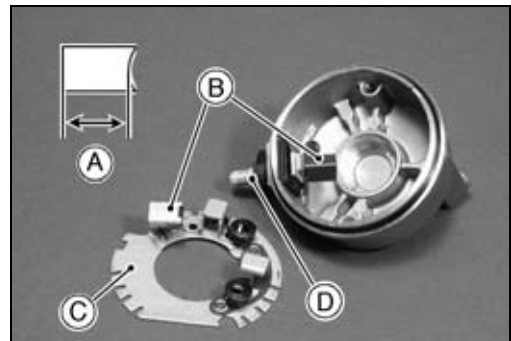

Commutator Cleaning and Inspection

- Smooth the commutator surface [A] if necessary with fine emery cloth [B], and clean out the grooves.

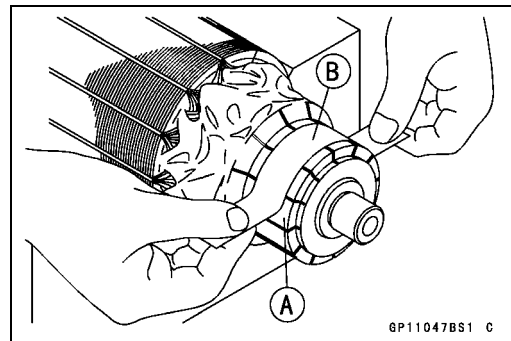

- Measure the diameter [A] of the commutator [B].
- ★ If the commutator diameter is less than the service limit, replace the starter motor with a new one.

Commutator Diameter

Standard: 28 mm (1.10 in.)

Service Limit: 27 mm (1.06 in.)

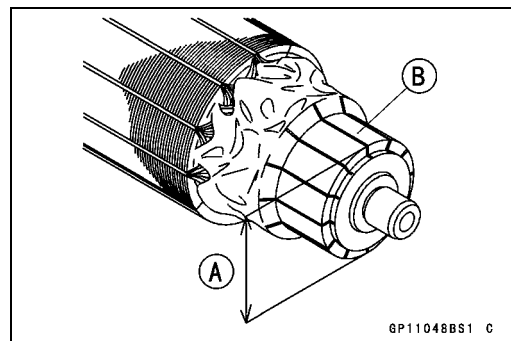

Electric Starter System

Armature Inspection

- Using the $\times 1 \Omega$ hand tester range, measure the resistance between any two commutator segments [A].
- ★ If there is a high resistance or no reading (∞) between any two segments, a winding is open and the starter motor must be replaced.
- Using the highest hand tester range, measure the resistance between the segments and the shaft [B].
- ★ If there is any reading at all, the armature has a short and the starter motor must be replaced.

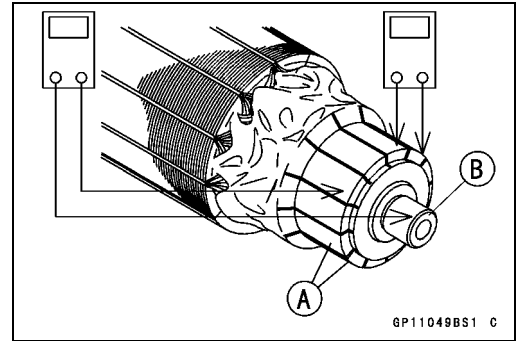

NOTE

○ Even if the foregoing checks show the armature to be good, it may be defective in some manner not readily detectable with the hand tester. If all other starter motor and starter motor circuit components check good, but the starter motor still does not turn over or only turns over weakly, replace the starter motor with a new one.

Brush Lead Inspection

- Using the $\times 1 \Omega$ hand tester range, measure the resistance as shown.
 - Terminal Bolt and Positive Brush [A]
 - Brush Plate and Negative Brush [B]
- ★ If there is not close to zero ohms, the brush lead has an open. Replace the terminal bolt assembly and/or the brush holder assembly.

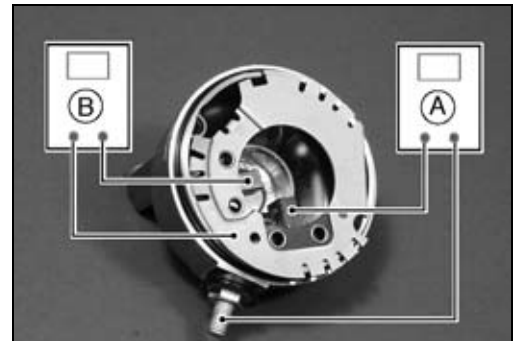

Brush Plate and Terminal Bolt Inspection

- Using the highest hand tester range, measure the resistance as shown.
 - Terminal Bolt and Brush Plate [A]
 - Terminal Bolt and Left-hand End Cover [B]
- ★ If there is any reading, the brush holder assembly and/or terminal bolt assembly have a short. Replace the brush holder assembly and the terminal bolt assembly.

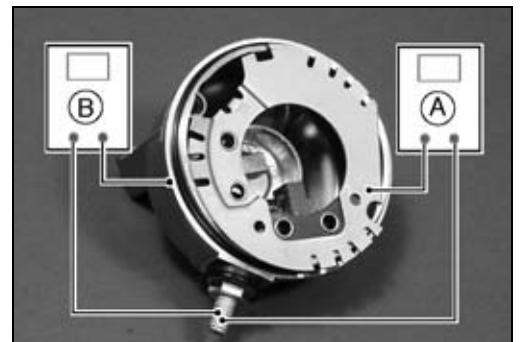

Starter Relay Inspection

- Remove:
 - Battery Tray (see Battery Removal)
 - Screw [A]
 - Cover [B]

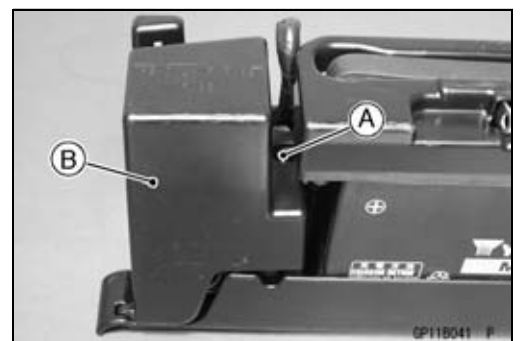

16-46 ELECTRICAL SYSTEM

Electric Starter System

- Remove:
 - Starter Cable [A]
 - Battery Cable [B] (disconnect)
 - Connector [C]
 - Starter Relay [D]

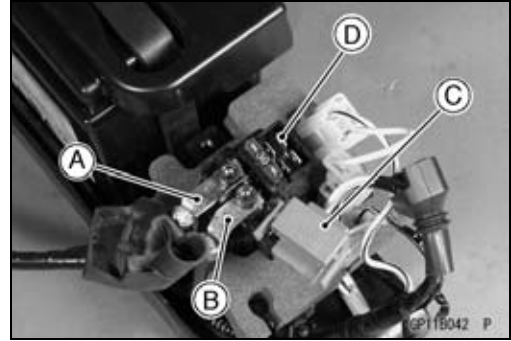

- Connect the hand tester [A] and 12 V battery [B] to the starter relay [C] as shown.
- ★ If the relay does not work as specified, the relay is defective. Replace the relay.

Testing Relay

Tester Range: × 1 Ω range

Criteria: When battery is connected → 0 Ω

When battery is disconnected → ∞ Ω

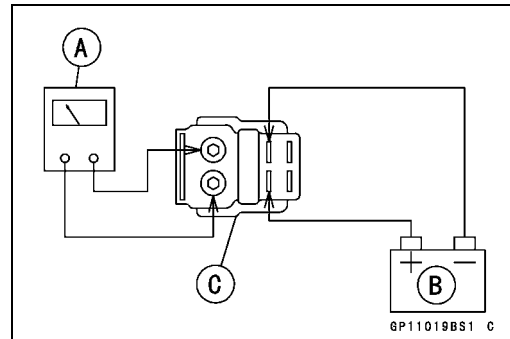

16-48 ELECTRICAL SYSTEM

Electric Starter System

ZX1200-B3

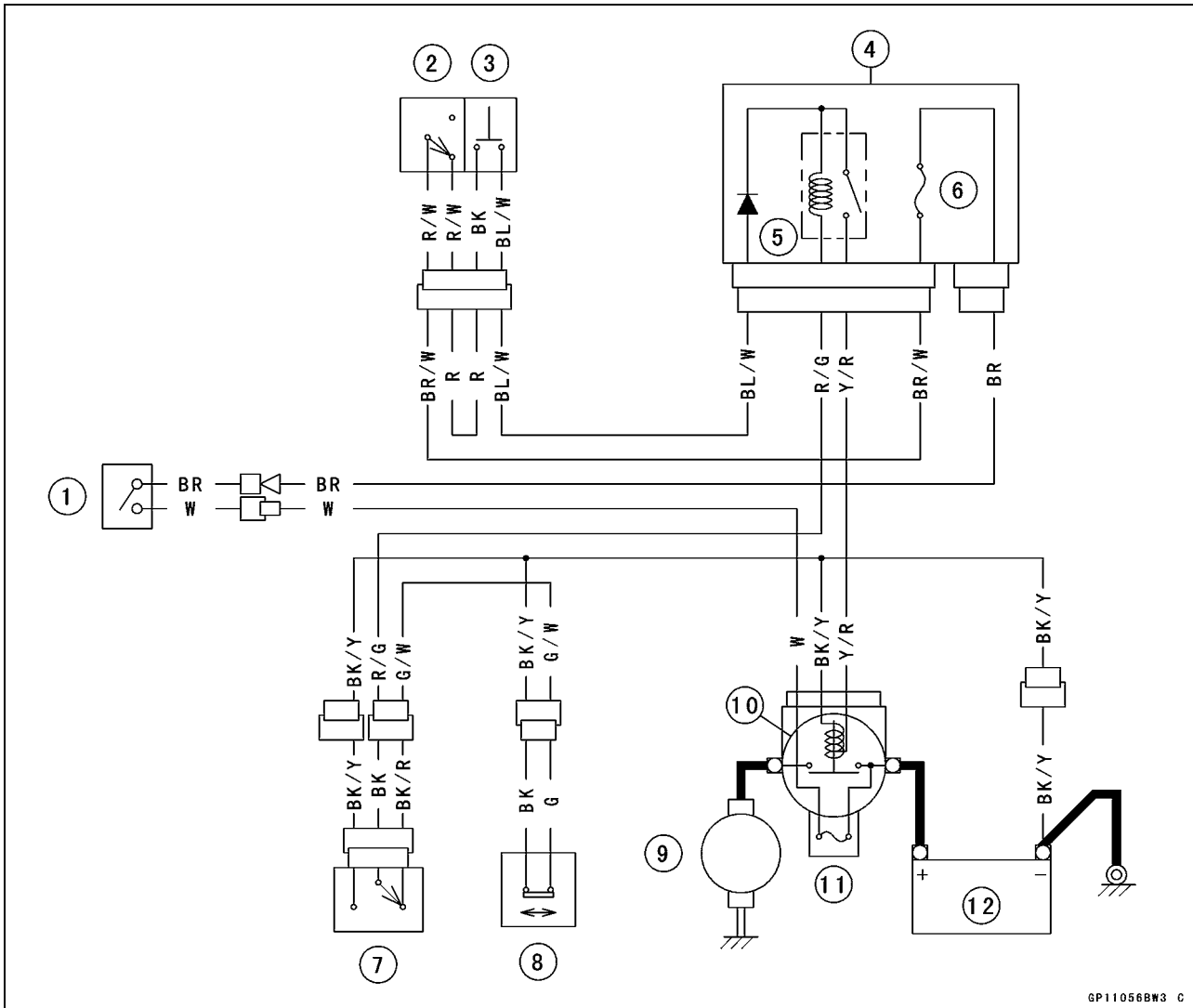

GP11056BW3 C

1. Ignition Switch
2. Engine Stop Switch
3. Starter Button
4. Junction Box
5. Starter Circuit Relay
6. Ignition Fuse 10 A
7. Starter Lockout Switch
8. Side Stand Switch
9. Starter Motor
10. Starter Relay
11. Main Fuse 30 A
12. Battery

Lighting System

The U.S.A., Canadian, Australian, and Malaysian models adopt the daylight system and have a headlight relay in the junction box. In these models, the headlight does not go on when the ignition switch and the engine stop switch are first turned on. The headlight comes on after the starter button is released and stays on until the ignition switch is turned off. The headlight will go out momentarily whenever the starter button is pressed and come back on when the button is released.

Headlight Beam Horizontal/Vertical Adjustment

- Remove the left and right lower inner covers [A] (see Frame chapter).



- Turn the left and right horizontal adjusters [A] on the headlight in or out until the beam points straight ahead.
- Turn the left and right vertical adjusters [B] on the headlight in or out to adjust the headlight vertically.

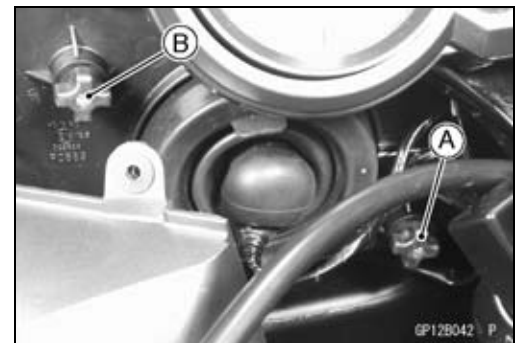

NOTE

- On high beam, the brightest points should be slightly below horizontal with the motorcycle on its wheels and the rider seated. Adjust the headlight(s) to the proper angle according to local regulations.
- For US model, the proper angle is 0.4 degrees below horizontal. This is 50 mm (2 in.) drop at 7.6 m (25 ft) measured from the center of the headlights with the motorcycle on its wheels and the rider seated.

50 mm (2 in.) [A]

Center of Brightest Spot [B]

7.6 m (25 ft) [C]

Height of Headlight Center [D]

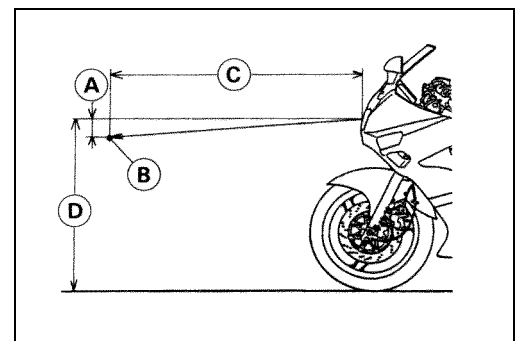

16-50 ELECTRICAL SYSTEM

Lighting System

Headlight Bulbs (Left and Right) Replacement

- Remove:
 - Left and Right Lower Inner Covers
 - Headlight Connectors
 - Headlight Bulb Dust Covers
 - Hooks [A]
 - Headlight Bulbs [B]

CAUTION

When handling the quartz-halogen bulb, never touch the glass portion with bare hands. Always use a clean cloth. Oil contamination from hands or dirty rags can reduce bulb life or cause the bulb to explode.

- Replace the headlight bulbs.
- Fit the dust cover [A] with the Top mark [B] upward onto the bulb [C] firmly as shown.
- After installation, adjust the headlight aim (see Headlight Beam Adjustment).

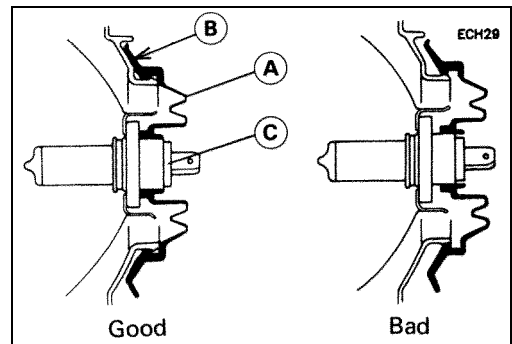
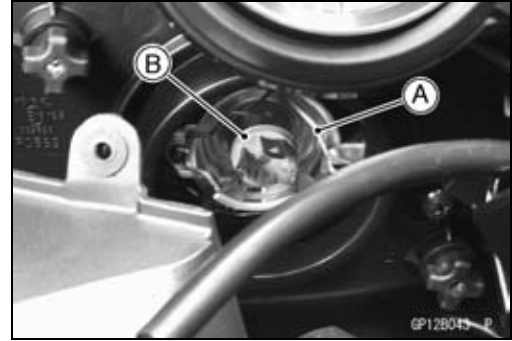

City Light Bulb Replacement

- Remove:
 - Wind Shield (see Frame chapter)
- Turn the socket [A] counterclockwise, and remove the socket and bulb.



- Pull the bulb [A] out of the socket.

CAUTION

Do not turn the bulb. Pull the bulb out to prevent damage to the bulb. Do not use bulb rated for greater wattage than the specified value.

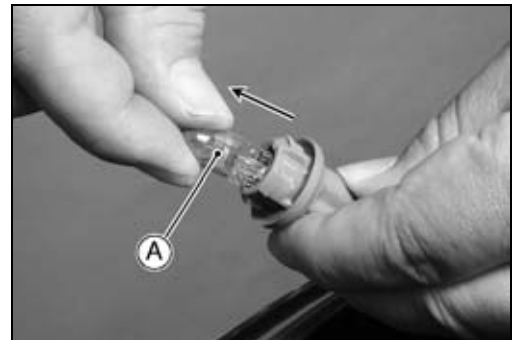

Lighting System

Tail/Brake Light Bulbs Replacement

- Remove:
 - Rear Seat (see Frame chapter)
 - Seat Cover (see Frame chapter)
- Turn the left and right sockets [A] counterclockwise, and remove the sockets and bulbs.

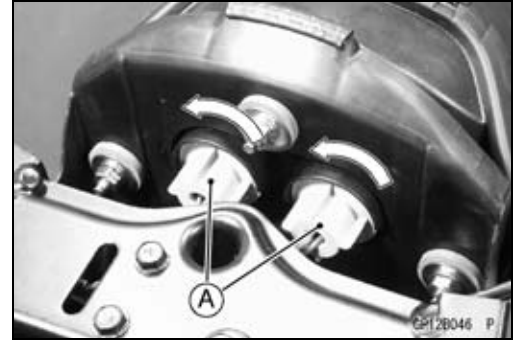

- Push and turn the bulb [A] counterclockwise and remove it.



- Insert a new bulb [A] by aligning its upper pin [B] with the upper groove [C] in the socket, and turn the bulb clockwise.

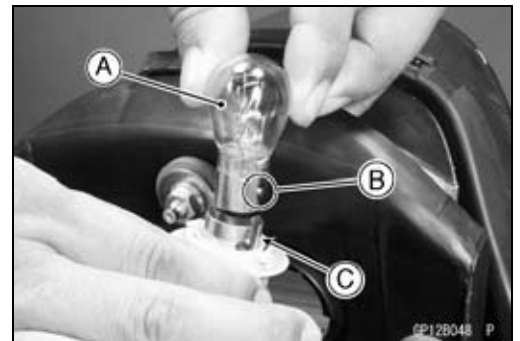

- Insert the socket by aligning its projection [A] with the upper groove [B], and turn it clockwise.

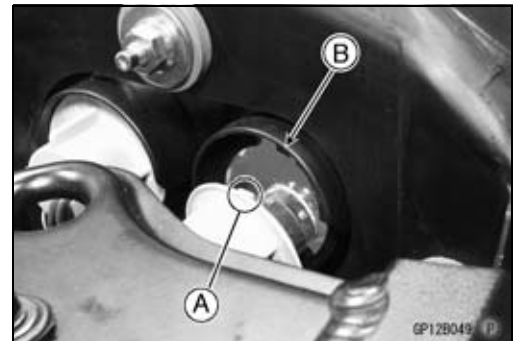

Tail/Brake Light Lens Assembly Replacement

- Remove:
 - Seat Cover (see Frame chapter)
 - Left and Right Socket [C]
 - Mounting Bolts [B]
 - Lens Assembly [A]
- Install:
 - Tighten the mounting bolts.
 - Torque - Tail/Brake Light Lens Bolts: 6.0 N·m (0.60 kgf·m, 53 in·lb)**

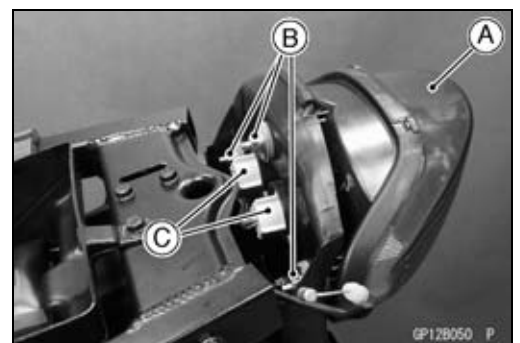

- Removed Parts

16-52 ELECTRICAL SYSTEM

Lighting System

Headlight Relay (High/Low) Inspection

- Remove:
 - Wind Shield (see Frame chapter)
 - Headlight Relay (High Beam) [A]

- Remove:
 - Headlight Relay (Low Beam) [A]
 - Right Upper and Lower Inner Covers (see Frame chapter)

- Connect the hand tester [A] and 12 V battery [B] to the headlight relay [C] as shown.
- ★ If the relay does not work as specified, the relay is defective. Replace the relay.

Testing Relay

Tester Range: $\times 1 \Omega$ range

Criteria: When battery is connected $\rightarrow 0 \Omega$
When battery is disconnected $\rightarrow \infty \Omega$

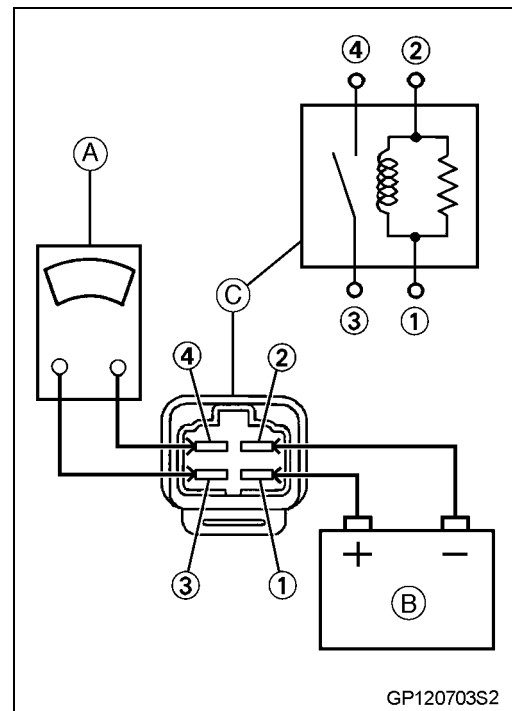
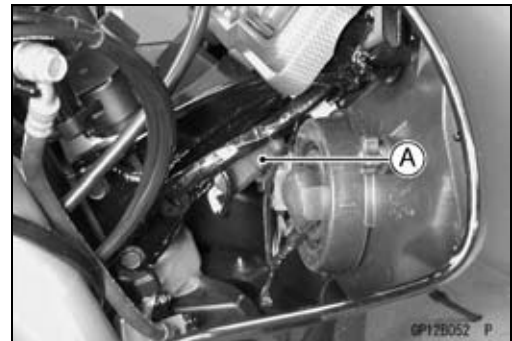
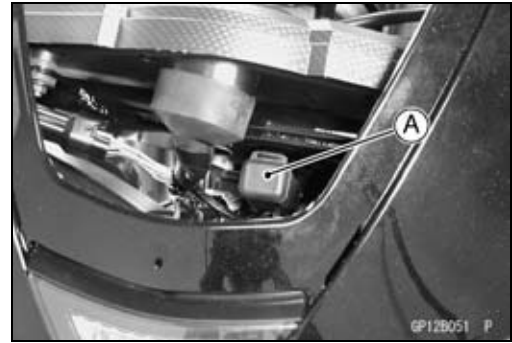

Lighting System

Headlight/Tail Light Circuit
ZX1200-B1/B2

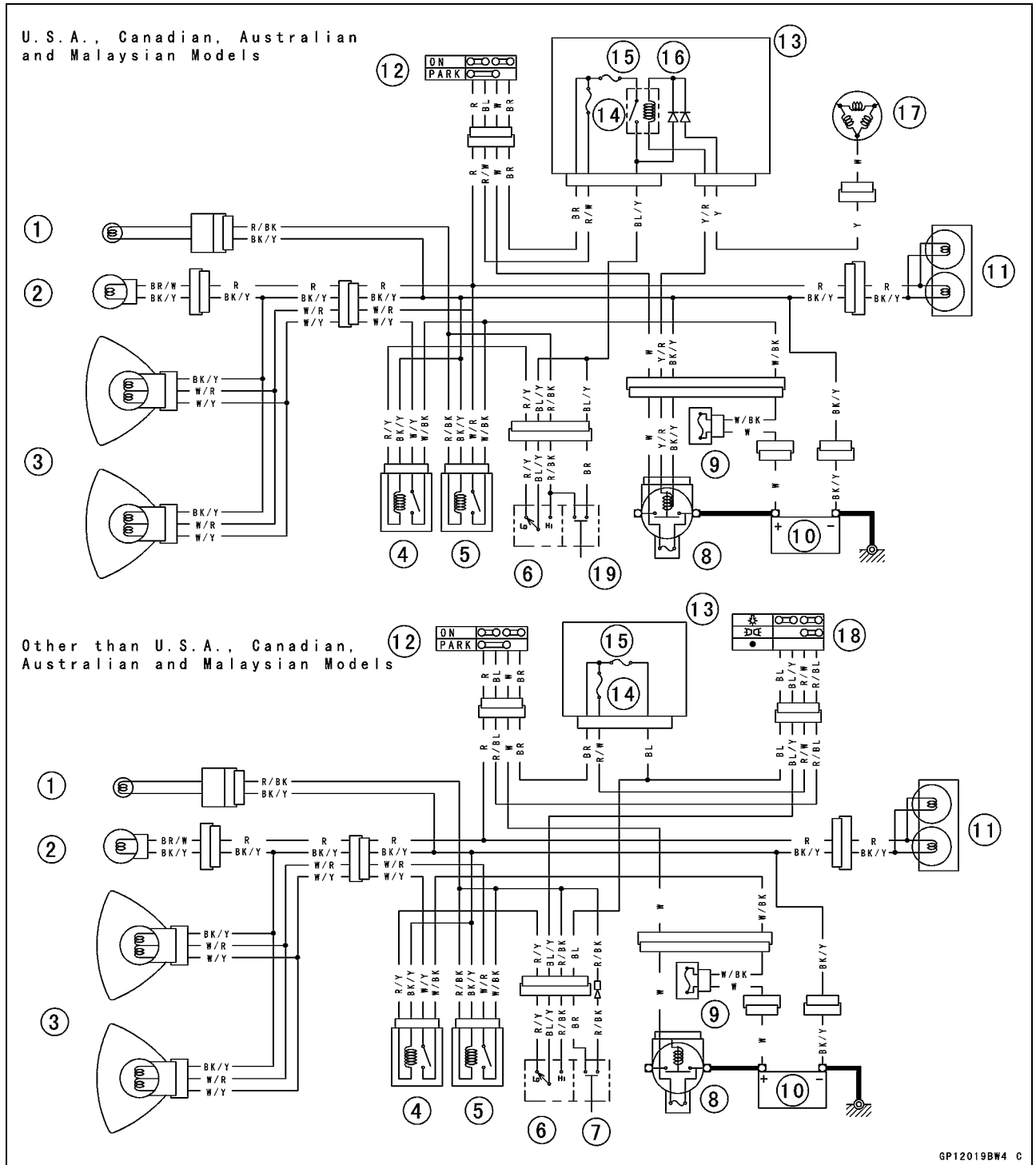

GP12019BW4 C

- | | |
|--------------------------------|-----------------------------------|
| 1. High Beam Indicator Light | 11. Tail Lights |
| 2. City Light | 12. Ignition Switch |
| 3. Headlights | 13. Junction Box |
| 4. Headlight Relay (Low Beam) | 14. Tail Light Fuse 10 A |
| 5. Headlight Relay (High Beam) | 15. Headlight Fuse 10 A |
| 6. Dimmer Switch | 16. Headlight Circuit Relay |
| 7. Passing Button | 17. Alternator |
| 8. Main Fuse 30 A | 18. Headlight Switch |
| 9. Headlight/Fan Fuse 30 A | 19. Passing Button |
| 10. Battery | (Australian and Malaysian Models) |

16-54 ELECTRICAL SYSTEM

Lighting System

ZX1200-B3

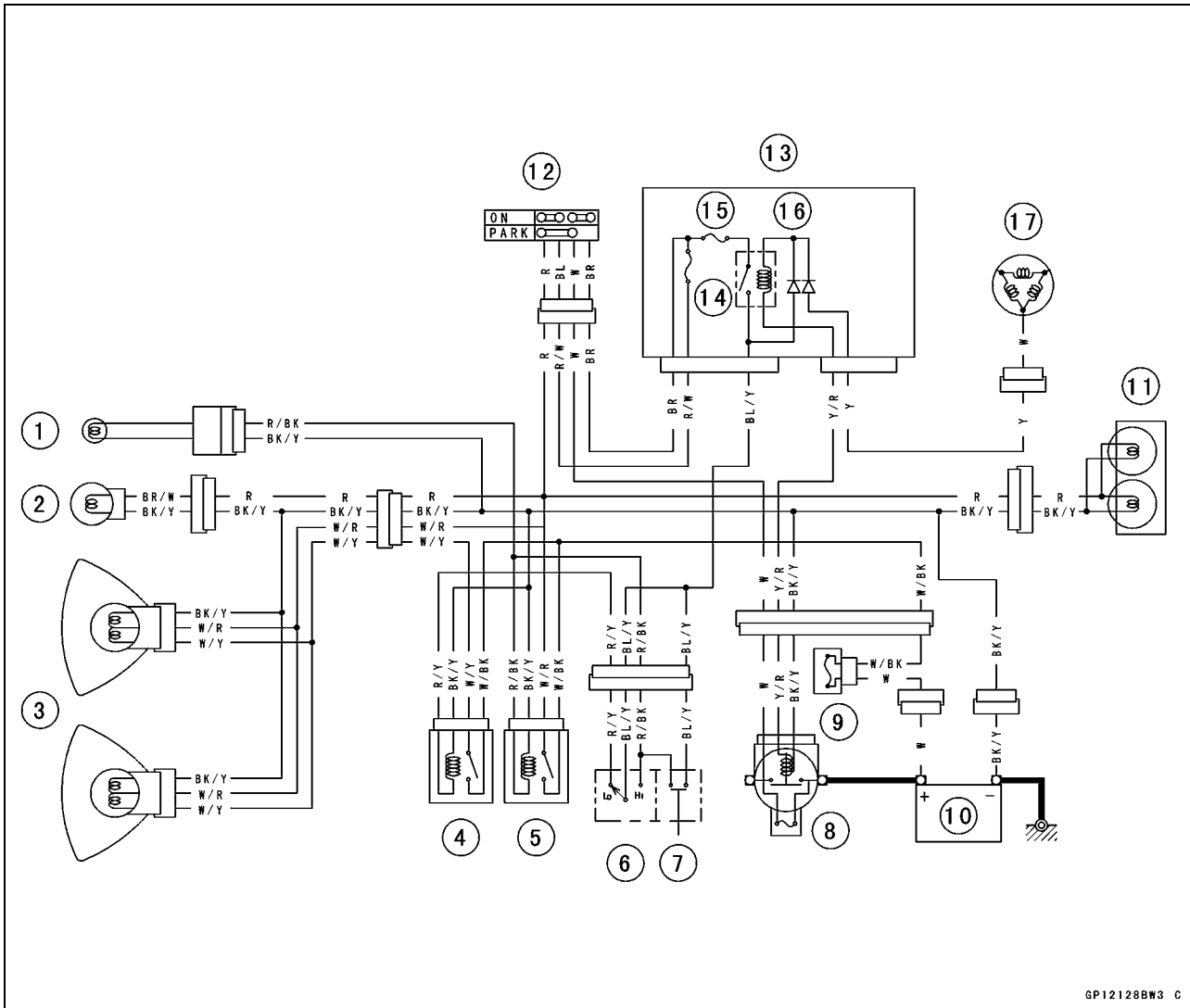

GP12128BW3 C

1. High Beam Indicator Light
2. City Light
3. Headlights
4. Headlight Relay (Low Beam)
5. Headlight Relay (High Beam)
6. Dimmer Switch
7. Passing Button
8. Main Fuse 30 A
9. Headlight/Fan Fuse 30 A

10. Battery
11. Tail Lights
12. Ignition Switch
13. Junction Box
14. Tail Light Fuse 10 A
15. Headlight Fuse 10 A
16. Headlight Circuit Relay
17. Alternator

Turn Signal Relay Inspection

- Remove:
 - Battery Tray (see Battery Removal)
 - Screw [A]
 - Cover [B]

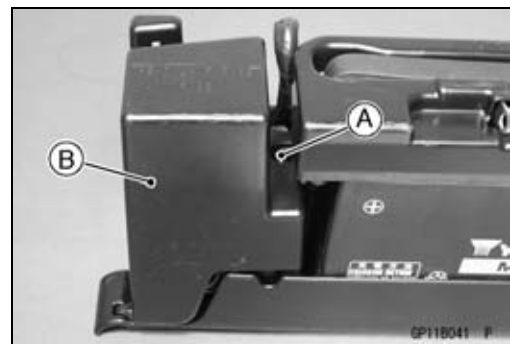

GP118041 P

Lighting System

- Remove:
Turn Signal Relay [A]



- Connect one 12 V battery and turn signal lights as indicated in the figure, and count how many times the lights flash for one minute.

Turn Signal Relay [A]
Turn Signal Lights [B]
12 V Battery [C]

- ★ If the lights do not flash as specified, replace the turn signal relay.

Testing Turn Signal Relay

Load		Flashing times (c/m*)
The Number of Turn Signal Lights	Wattage (W)	
1	21 or 23	140 – 250
2	42 or 46	75 – 95

*: Cycle(s) per minute

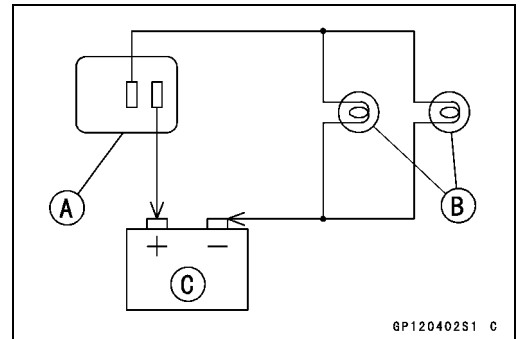

16-56 ELECTRICAL SYSTEM

Lighting System

Turn Signal Light Circuit

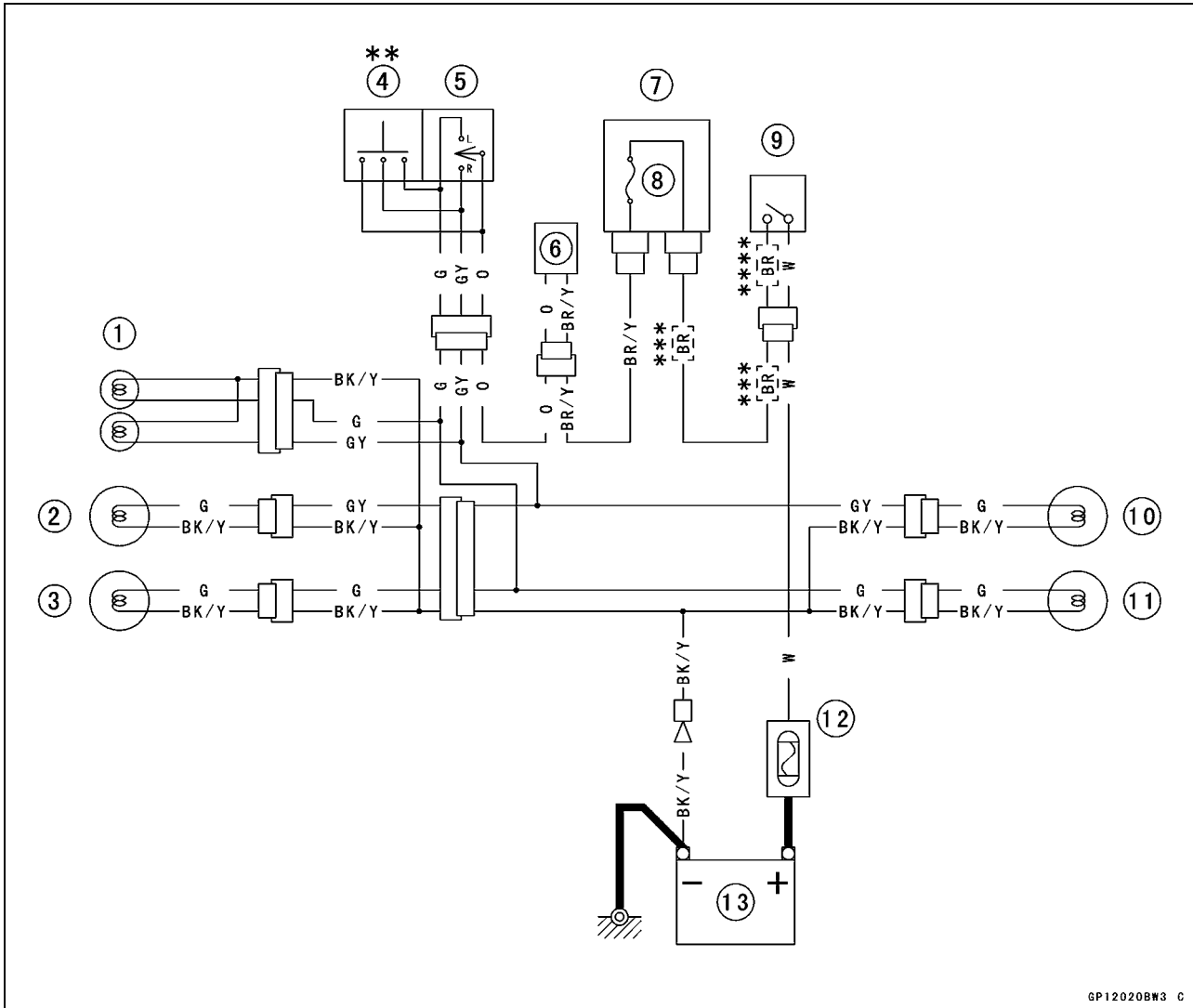

1. Turn Signal Indicator Lights (Right and Left)
 2. Front Right Turn Signal Light
 3. Front Left Turn Signal Light
 4. Hazard Button
 5. Turn Signal Switch
 6. Turn Signal Relay
 7. Junction Box
 8. Turn Signal Relay Fuse 10 A
 9. Ignition Switch
 10. Rear Right Turn Signal Light
 11. Rear Left Turn Signal Light
 12. Main Fuse 30 A
 13. Battery
- ** : US, CA and MY models are equipped [4].
*** : US, CA and MY models lead is O/G.
**** : US, CA and MY models lead is W/G.
US: U.S.A. Model
CA: Canadian Model
MY: Malaysian Model

Air Switching Valve (ZX1200-B3)

Air Switching Valve Operation Test

- Pull the air switching valve hose out of the air cleaner base.
- Start the engine and run it at idle speed.
- Plug [A] the air switching valve hose [B] end with your finger and feel vacuum pulsing in the hose.
- ★ If there is no vacuum pulsation, check the hose line for leak. If there is no leak, check the air switching valve (see Air Switching Valve Unit Test).
- Apply a soap and water solution or rubber lubricant to the end of the air switching valve hose and install the hose on the fitting.

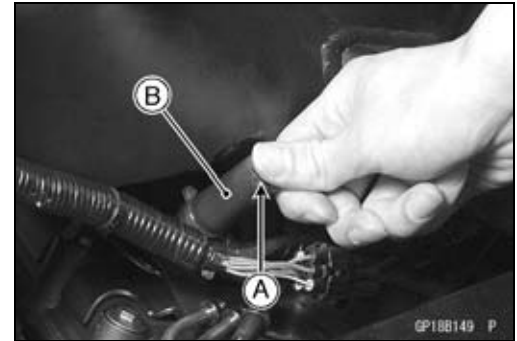

Air Switching Valve Unit Test

- Remove the air switching valve (see Engine Top End chapter).
- Set the hand tester [A] to the $\times \Omega$ range and wire it to the air switching valve terminals as shown.

Special Tool - Hand Tester: 57001-1394

Air Switching Valve Resistance

Standard: 18 ~ 22 Ω at 20°C (68°F)

- ★ If the resistance reading is except the specified value, replace it with a new one.
- Connect the 12 V battery [A] to the air switching valve terminals as shown.

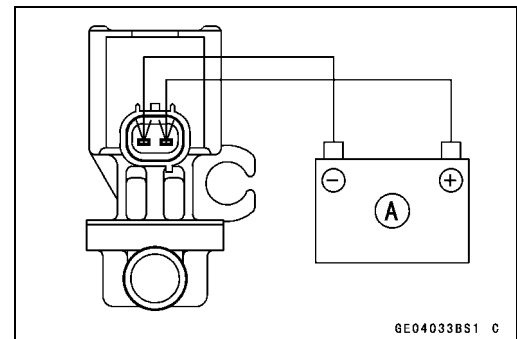
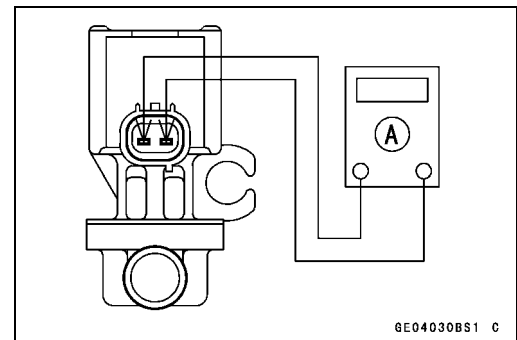

- Blow the air to the inlet air duct [A], and make sure does not flow the blown air from the outlet air ducts [B].

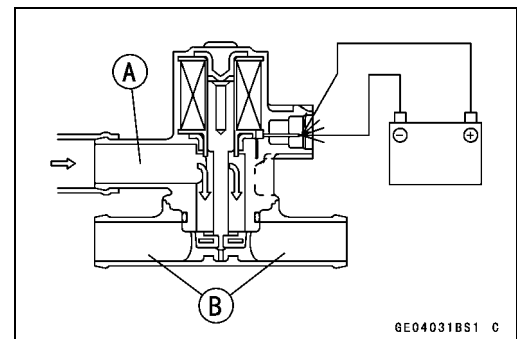

- Disconnect the 12 V battery.
- Blow the air to the inlet air duct [A] again, and make sure flow the blown air from the outlet air ducts [B].
- ★ If the air switching valve dose not operate as described, replace it with a new one.

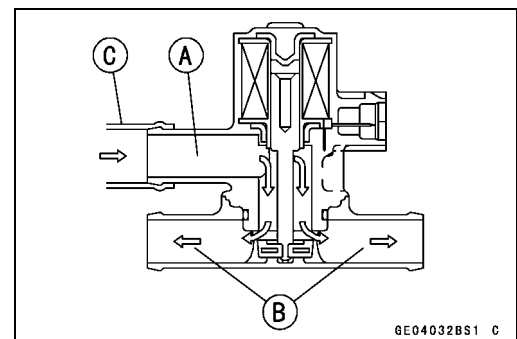

NOTE

- To check air flow through the air switching valve, just blow through the air cleaner hose [C].

16-58 ELECTRICAL SYSTEM

Radiator Fan System

Fan System Circuit Inspection

- Remove the left lower fairing (see Frame chapter).
- Disconnect the connector [A] from the radiator fan switch.
- Using an auxiliary lead, connect it to the terminals in the connector.
- ★ If the fan rotates, inspect the fan switch.
- ★ If the fan does not rotate, inspect the following.
 - Leads and Connectors
 - Main Fuse and Fan Fuses
 - Fan Motors
 - Fan Relay



Fan Motors Inspection

- Remove the left lower inner cover (see Frame chapter).
- Disconnect the 2-pin connectors [A] in the fan motor leads.
- Using two auxiliary leads, supply battery [B] power to the fan motor one by one.
- ★ If the fan does not rotate, the fan motor is defective and must be replaced.

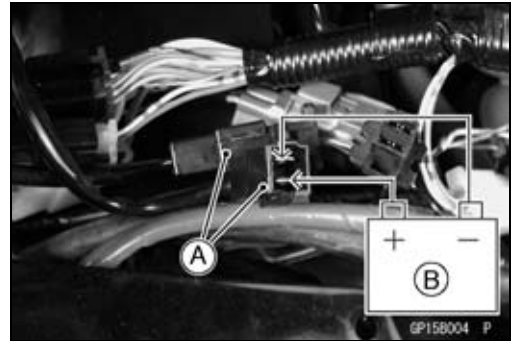

Fan Relay Removal

CAUTION

Never drop the relay, especially on a hard surface. Such a shock to the relay can damage it.

- Remove:
 - Fuel Tank Cover (see Fuel Tank Removal in the Fuel System (DFI) chapter)
 - Bracket Bolt [A]
- Remove the fan relay [B] with disconnecting the connectors.

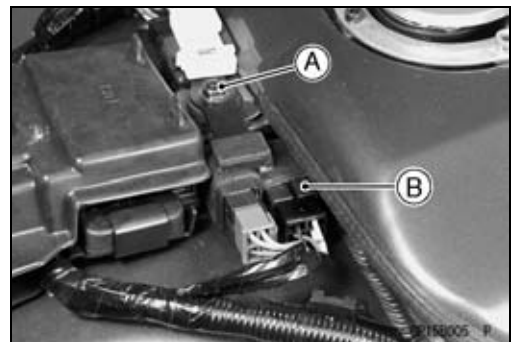

Radiator Fan System

Fan Relay Inspection

- Remove the fan relay (see Fan Relay Removal).
- Connect the hand tester [A] and one 12 V battery [B] to the relay connector [C] as shown.

Special Tool - Hand Tester: 57001-1394

Relay Coil Terminals [1] and [2]

Relay Switch Terminals [3] and [4]

Testing Relay

Tester range: 1 Ω range

Criteria: When battery is connected → 0 Ω

When battery is disconnected → ∞ Ω

★If the relay does not work as specified, replace the relay.

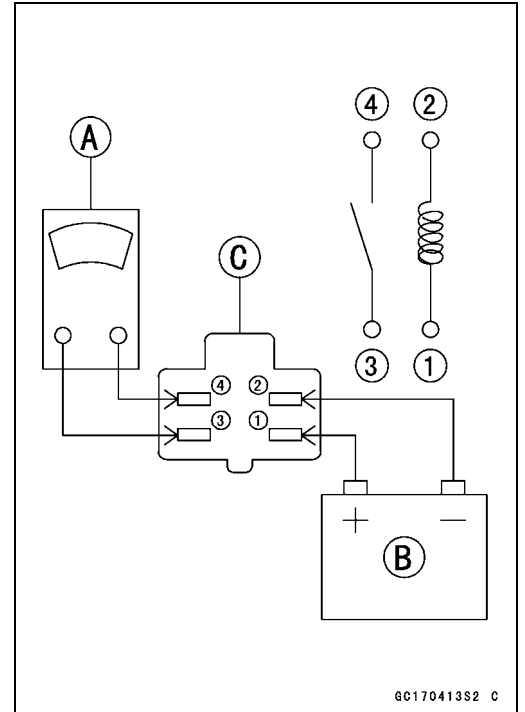

GC170413S2 C

Radiator Fan Circuit

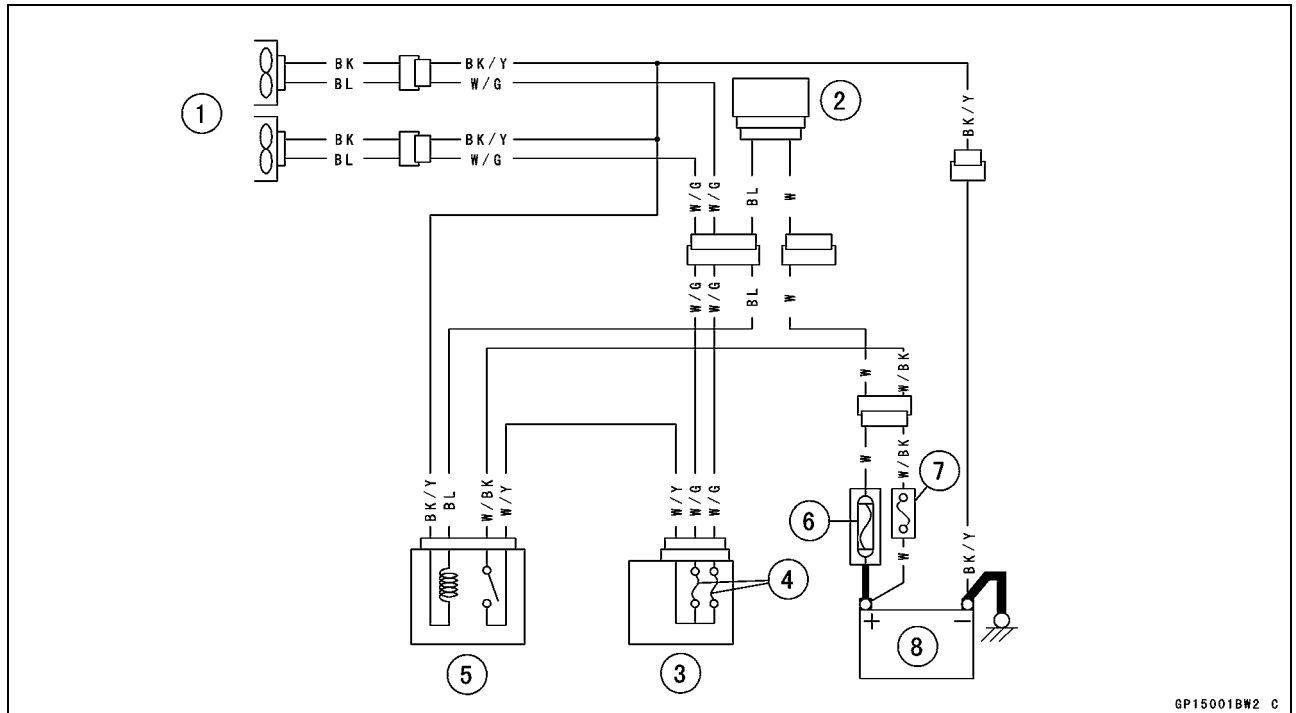

GP15001BW2 C

1. Radiator Fans

2. Radiator Fan Switch

3. Junction Box

4. Fan Fuses 15 A

5. Fan Relay

6. Main Fuse 30 A

7. Fan Fuse 30A

8. Battery

16-60 ELECTRICAL SYSTEM

Meter

Meter Unit Removal

- Remove:
 - Wind Shield (see Frame chapter)
- Slide the dust cover [A] and remove the wiring connector [B].
- Remove:
 - Mounting Nuts [C]
 - Meter Unit [D]

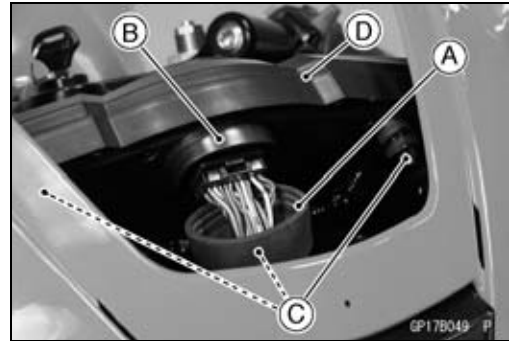

CAUTION

Do not drop the meter unit.

Meter Unit Disassembly

- Remove:
 - Meter Unit (see Meters Unit Removal)
 - Screws [A]
 - Meter Cover [B]
-
- Separate the meter assembly [A] and meter covers [B].

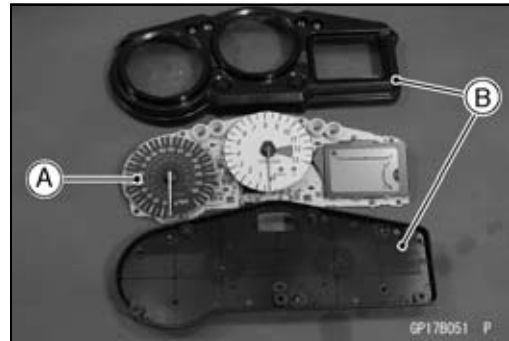
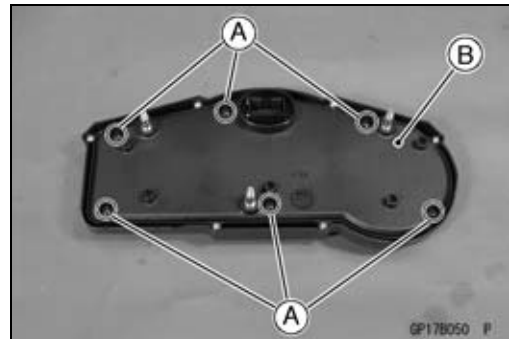

- Remove the screws [A] to separate the inner and outer cover of the upper cover.

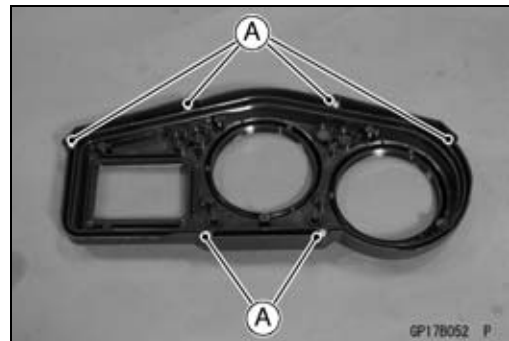

Bulbs Replacement

- Remove:
 - Lower Meter Cover (see Meter Unit Disassembly)
- Turn out the sockets [A] counterclockwise to pull the bulbs out the sockets.

CAUTION

Do not turn the bulb. Pull the bulb out to prevent damage to the bulb. Do not use bulb rated for greater wattage than the specified value.

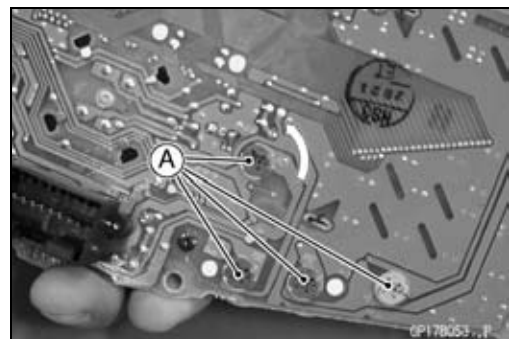

Meter

Meter Unit Inspection

- Remove:
Meter Unit [A] (see Meter Unit Removal)

CAUTION

Do not drop the meter unit.

- [1] Tachometer Pulse
- [2] Fuel Level Sensor
- [3] Oil Pressure Warning Indicator Light (LED) Ground
- [4] Left Turn Signal Indicator Light (+)
- [5] Right Turn Signal Indicator Light (-)
- [6] High Beam Indicator Light (+)
- [7] Neutral Indicator Light (-)
- [8] Turn Signal, High Beam Indicator and Meter Lights (-)
- [9] Speed Sensor Pulse
- [10] Water Temperature Sensor
- [11] Fuel Reserve Switch
- [12] Battery (-)
- [13] Speed Sensor Supply Voltage
- [14] Ignition
- [15] Battery (+)
- [16] Meter Lights (+)
- [20] FI Indicator Light (LED) Ground

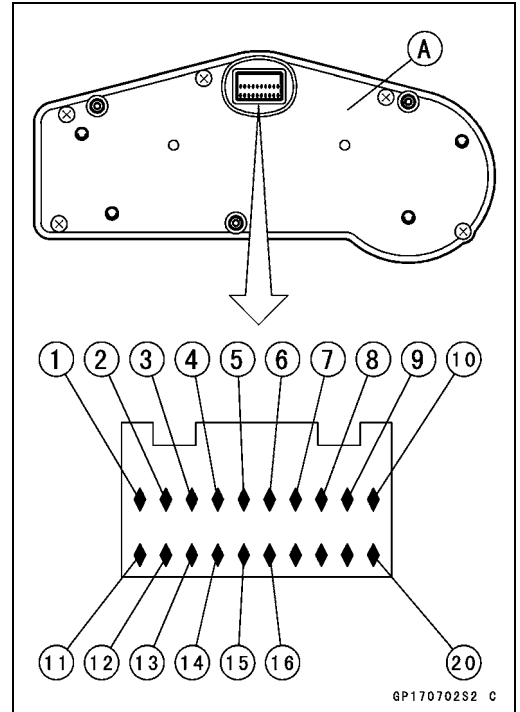

CAUTION

Do not short terminals [12] to [13] and [13] to [9].

Check 1: Liquid Crystal Display (LCD) Segments Check/Speedometer and Tachometer Primary Operation Check

- Using the auxiliary leads, connect a 12 V battery to the meter unit connector as follows.
- Connect the battery positive terminal to terminal [15].
- Connect the battery negative terminal to terminal [12].
- The speedometer and tachometer needles momentarily point to their last readings.
- ★If the meters do not work, replace the meter assembly.
- Connect terminal [15] to terminal [14].
- The speedometer and tachometer needles momentarily point to their last readings.
- All the LCD segments appear for three seconds.
- ★If the meters and/or segments do not work, replace the meter assembly.
- Disconnect the terminal [14].
- All the LCD segments disappear.
- ★If the segments do not disappear, replace the meter assembly.

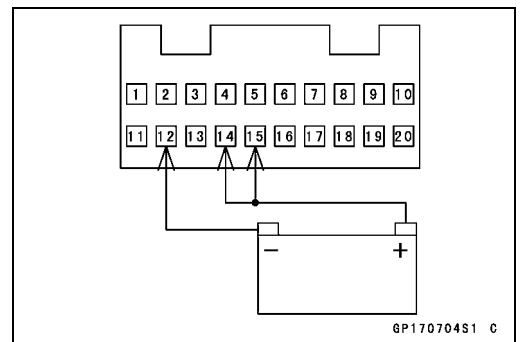
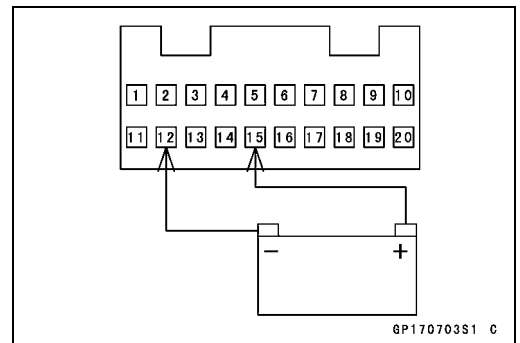

16-62 ELECTRICAL SYSTEM

Meter

Check 2: CLOCK/TRIP A and ODO/TRIP B Button Operation Check

- Connect the leads in the same circuit as for the Check 1.
- Check that when the CLOCK/TRIP A button [A] is pushed within two seconds, the display [B] cycles through the two modes.

CLOCK → TRIP A → CLOCK

★ If this display function does not work, replace the meter assembly.

- Cycle the display to the CLOCK mode [A].
- Check that when the CLOCK/TRIP A button [B] is pushed for more than two seconds, the display changes to the clock set mode.
- Check that when the clock set mode, it is possible to adjust the hours and minutes.

★ If this display function does not work and adjust, replace the meter assembly.

- Cycle the display to the TRIP A mode [A].
 - Check that when the CLOCK/TRIP A button [B] is pushed for more than two seconds, the display turns to 0.0.
- ★ If this display function does not indicate 0.0, replace the meter assembly.

- Check that when the ODO/TRIP B button [A] is pushed within two seconds, the display [B] cycles through the two modes.

ODO → TRIP B → ODO

★ If this display function does not work, replace the meter assembly.

- Cycle the display to the TRIP B mode [A].
 - Check that when the ODO/TRIP B button [B] is pushed for more than two seconds, the display turns to 0.
- ★ If this display function does not indicate 0, replace the meter assembly.

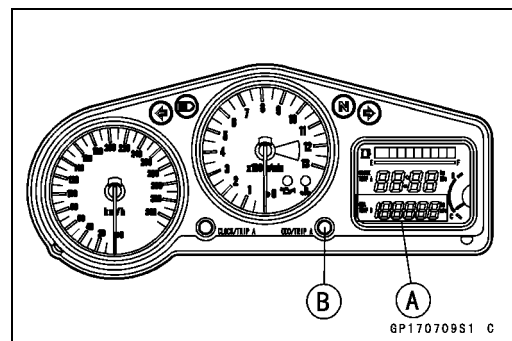
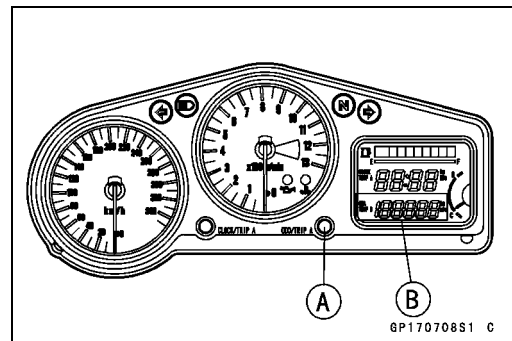
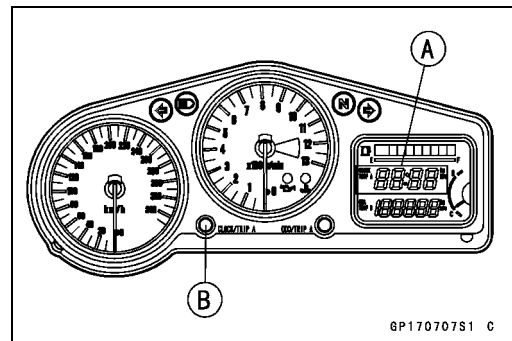
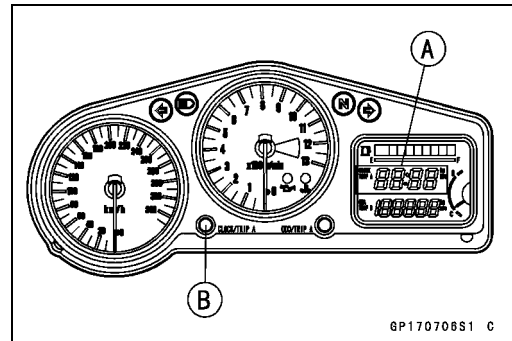
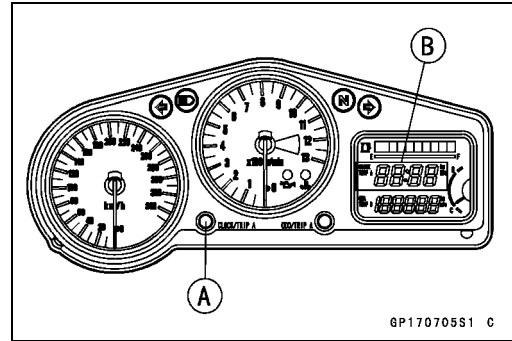

Meter

Check 3: Speedometer Check

- Connect the leads in the same circuit as for the Check 1.
- The speed equivalent to the input frequency is indicated in the oscillator [A], if the square wave is input into terminal [9].
- Indicates approximately 60 mph if the input frequency is approximately 1 083 Hz.
- Indicates approximately 60 km/h if the input frequency is approximately 677 Hz.
- ★ If this meter function does not work, replace the meter assembly.

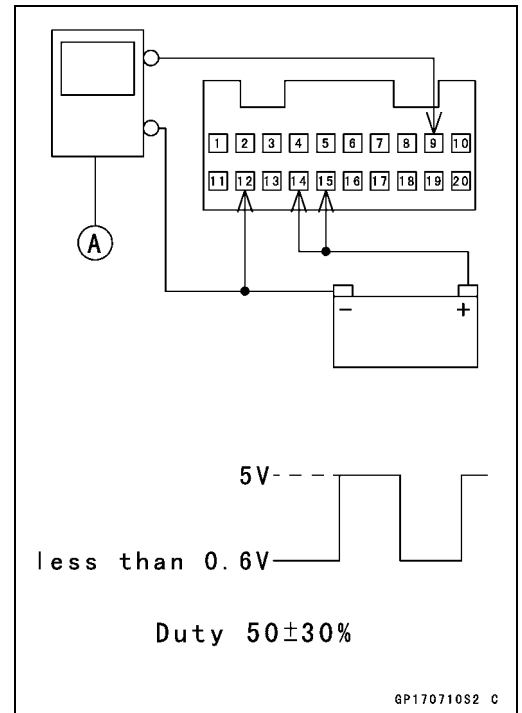

Check 4: Speed Sensor Supply Voltage Check

- Connect the leads in the same circuit as for the Check 1.
- Set the hand tester [A] to the DC 25 V range and connect it to terminals [13] and [12].
- Hand Tester (+) to Terminal 13
- Hand Tester (-) to Terminal 12

CAUTION

Do not short terminals 13 to 12.

- ★ If the voltage is not more than 7 V, replace the meter assembly.

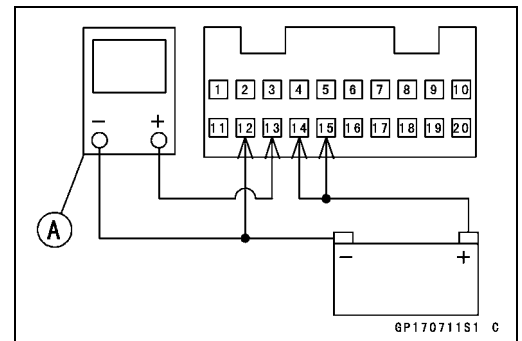

Check 5: ODO Meter Check

- Connect the leads in the same circuit as for the Check 3.
- Cycle the display to the ODO mode [A].
- Raise the input frequency of the oscillator to quickly see the result of this inspection.
- ★ If the value indicated by the odometer does not increase, replace the meter assembly.

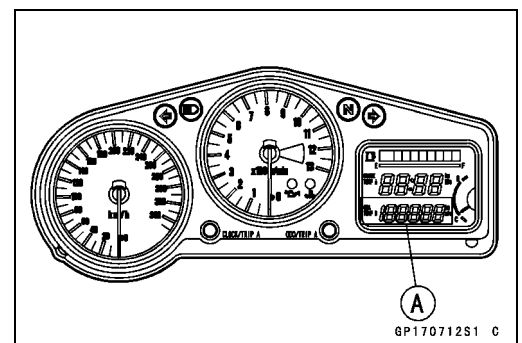

16-64 ELECTRICAL SYSTEM

Meter

Check 6: TRIP A/TRIP B Meter Check

- Connect the leads in the same circuit as for the Check 3.
- Cycle the display to the TRIP A [A] or TRIP B [B] mode.
- Raise the input frequency of the oscillator to quickly see the result of this inspection.
- ★ If the value indicated by the trip meter A or B does not increase, replace the meter assembly.

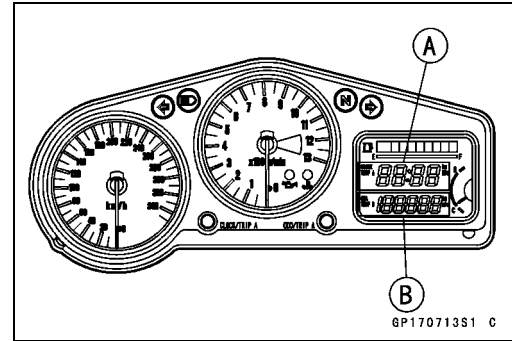

Check 7: Tachometer Check

- Connect the leads in the same circuit as for the Check 1.
- The engine speed (rpm) equivalent to the input frequency is indicated in the oscillator [A], if the square wave is input into terminal [1].
- Indicates approximately 3 000 rpm if the input frequency is approximately 100 Hz.
- ★ If this meter function does not work, replace the meter assembly.

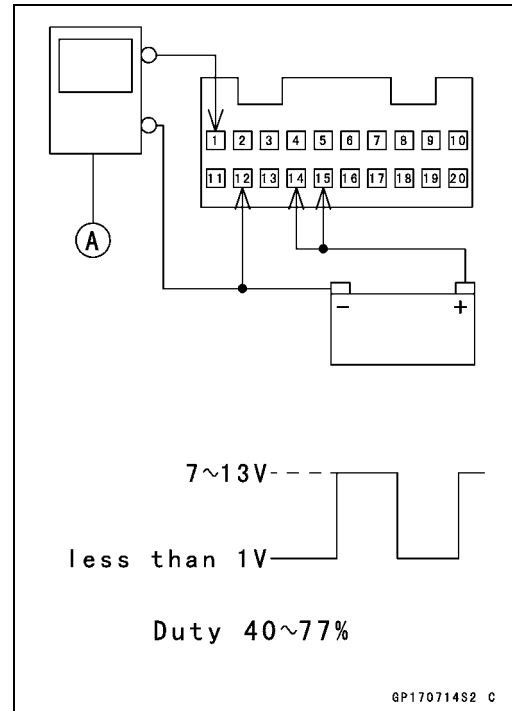

Meter

Check 8: Coolant Temperature Gauge Inspection

- Connect the leads in the same circuit as for the Check 1.
- Connect a variable rheostat [A] to terminal [10] and [12] as shown.
- Check that the position of segment [B] matches the resistance value of the variable rheostat.

B1 Model

Resistance (Ω)	Position of Segment	Coolant Temperature (Reference)
16 500	1st	less than 30°C (86°F)
11 000	2nd	30°C (86°F) ~ 50°C (122°F)
6 200	3rd	50°C (122°F) ~ 60°C (140°F)
3 800	4th	60°C (140°F) ~ 80°C (176°F)
1 800	5th	80°C (176°F) ~ 100°C (212°F)
1 100	6th	100°C (212°F) ~ 110°C (230°F)
850	7th	110°C (230°F) ~ 115°C (239°F)
740	8th	115°C (239°F) ~ 120°C (248°F)
660	9 (All, Flash)	120°C (248°F) or more

B2/B3 Model

Resistance (Ω)	Position of Segment	Coolant Temperature (Reference)
14 200	1st	less than 34°C (93°F)
10 200	2nd	34°C (93°F) ~ 53°C (127°F)
5 200	3rd	53°C (127°F) ~ 64°C (147°F)
3 100	4th	64°C (147°F) ~ 84°C (183°F)
1 600	5th	84°C (183°F) ~ 105°C (221°F)
900	6th	105°C (221°F) ~ 115°C (239°F)
740	7th	115°C (239°F) ~ 120°C (248°F)
650	8th	120°C (248°F) ~ 125°C (257°F)
600	All, Flash	125°C (257°F) or more

Resistance values are standard and they have tolerance.
 ★If this display function does not work, replace the meter assembly.

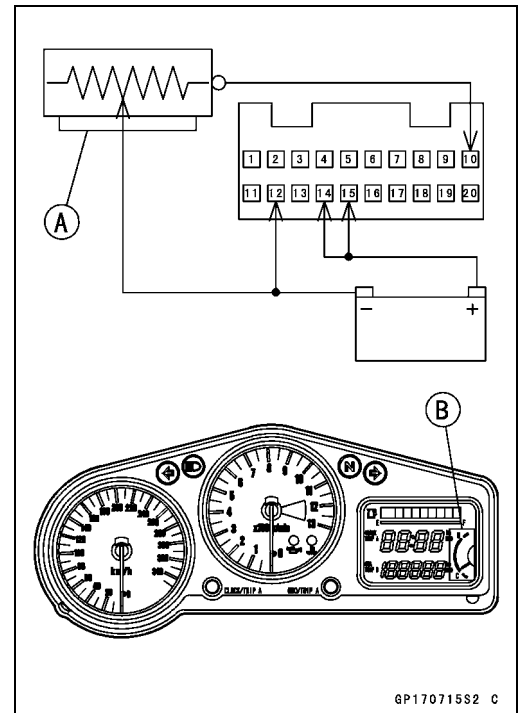

GP170715S2 C

16-66 ELECTRICAL SYSTEM

Meter

Check 9: Fuel Gauge Inspection

- Connect the leads in the same circuit as for the Check 1.
- Connect a variable rheostat [A] to terminal [2] and [12] as shown.
- Check that the number of segment [B] matches the resistance value of the variable rheostat.

Resistance (Ω)	Number of Segments	Fuel Amount (Reference) (L)
10	8	20
30	7	18
40	6	16
65	5	13
75	4	11
90	3	9
100	2	7
120	1	5

Resistance values are standard and they have tolerance.

★ If this display function does not work, replace the meter assembly.

- Connect an other variable rheostat [C] to terminal [11] and [12].
- Set the hand tester [D] to the DC 10 V range and connect it to terminals of the variable rheostat as shown.
- When the 1 segment [E] appears, adjust the variable rheostat [C] so that the terminal voltage is less than 5.7 V.
- Then the segment should flush.
- ★ If this display function does not flush, replace the meter assembly.

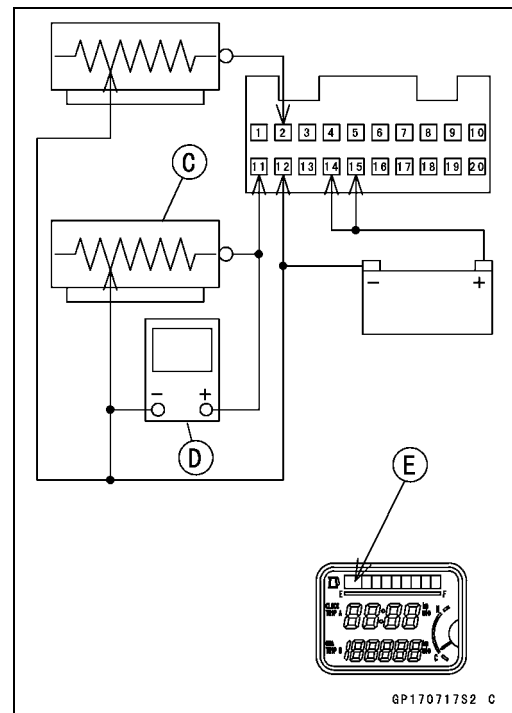
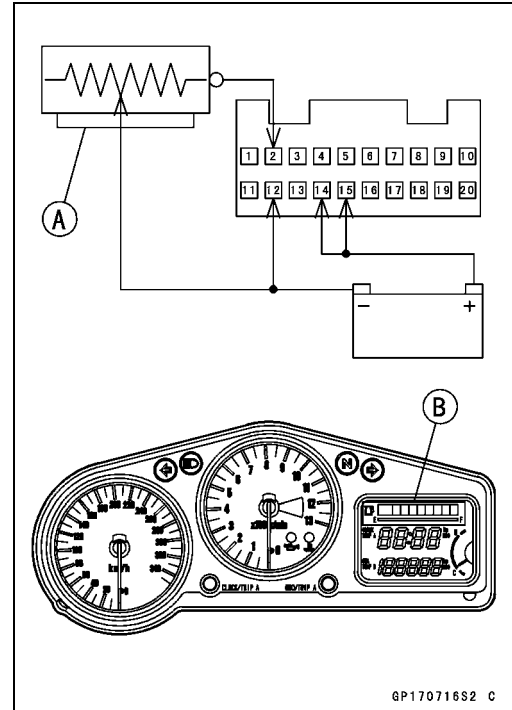

Meter**Check 10: LED Light Inspection**

- Using the auxiliary leads, connect a 12 V battery to the meter unit connector as follows.

Oil Pressure Warning Indicator Light (LED) [A]:

Battery Positive (+) Terminal to Terminal [14]

Battery Negative (-) Terminal to Terminal [3]

FI Indicator Light (LED) [B]:

Battery Positive (+) Terminal to Terminal [14]

Battery Negative (-) Terminal to Terminal [20]

- ★ If each LED light does not go on, replace the meter assembly.

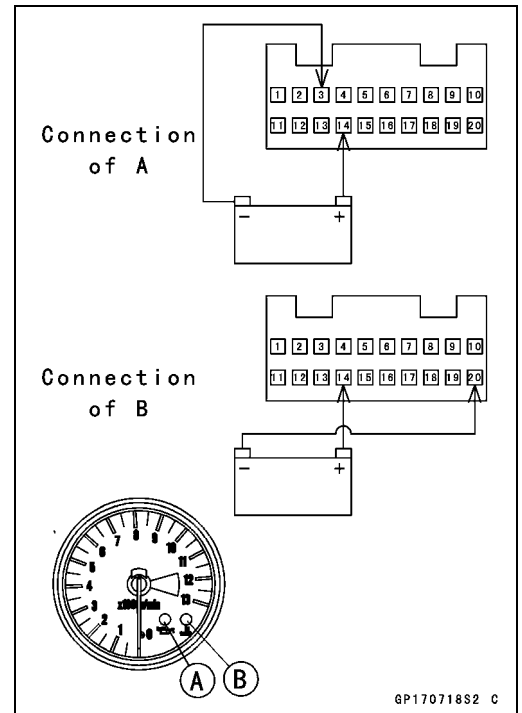

16-68 ELECTRICAL SYSTEM

Meter

Meter Circuit ZX1200-B1/B2

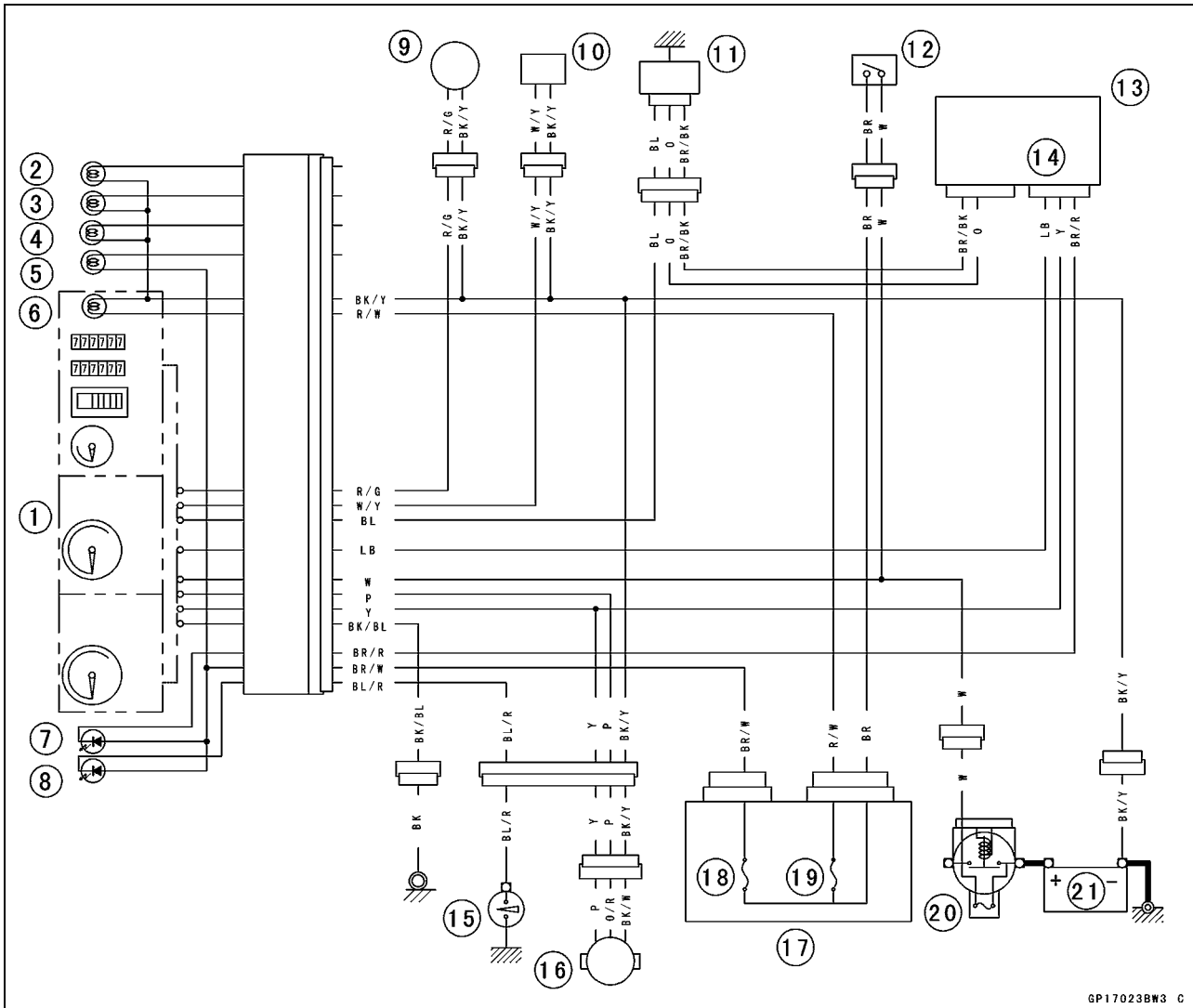

GP17023BW3 C

1. Meter Unit
2. High Beam Indicator Light 12 V 1.1 W
3. Left Turn Signal Indicator Light 12 V 1.1 W
4. Right Turn Signal Indicator Light 12 V 1.1 W
5. Neutral Indicator Light 12 V 1.1 W
6. Meter Lights 12 V 1.1 W × 3, 12 V 0.7 W × 2
7. FI Indicator Light (LED)
8. Oil Pressure Warning Indicator Light (LED)
9. Fuel Reserve Switch
10. Fuel Level Sensor
11. Water Temperature Sensor
12. Ignition Switch
13. ECU
14. Tachometer Signal
15. Oil Pressure Switch
16. Speed Sensor
17. Junction Box
18. Ignition Fuse 10 A
19. Tail Light Fuse 10 A
20. Main Fuse 30 A
21. Battery

Meter

ZX1200-B3

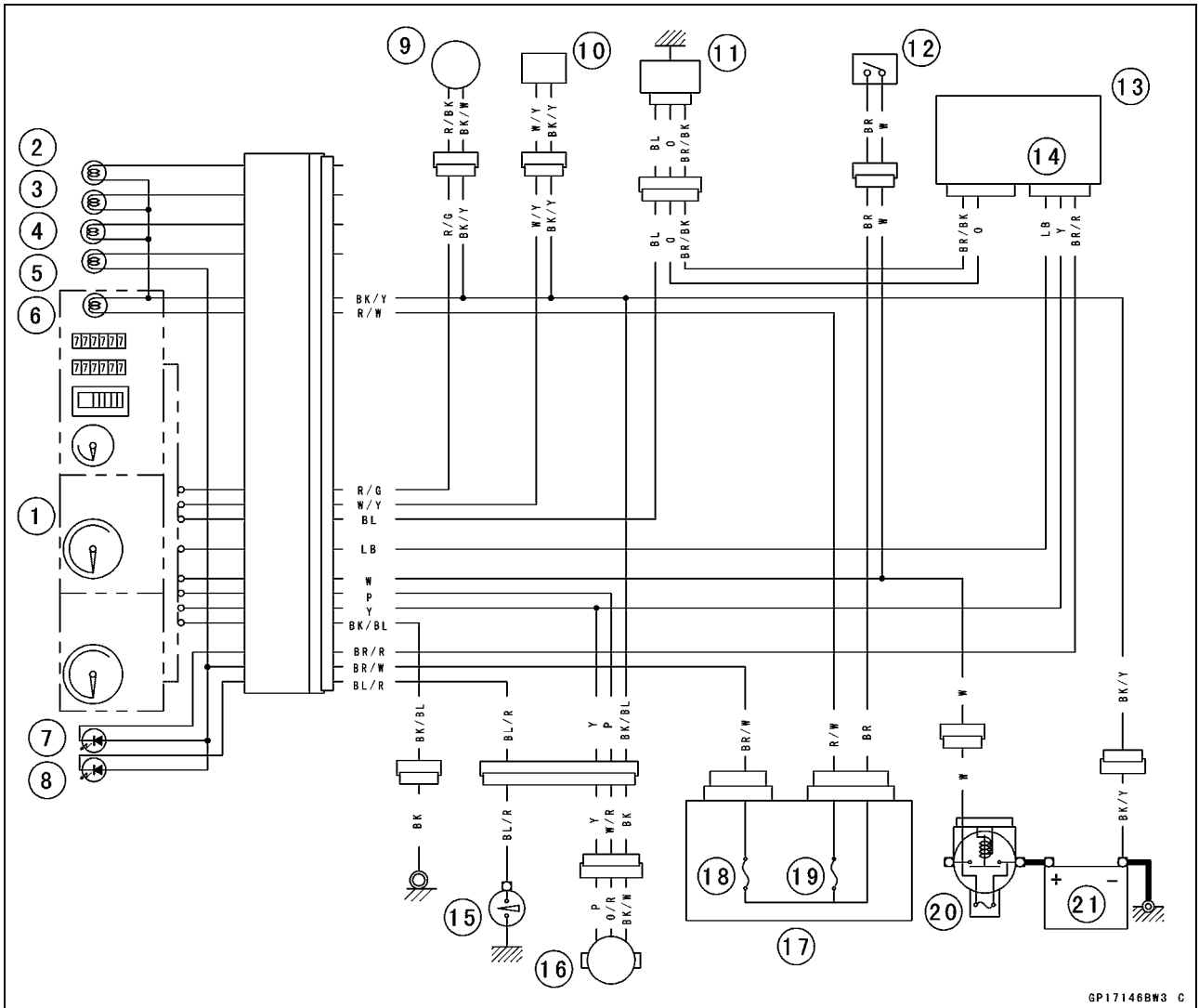

GP17146BW3 C

1. Meter Unit
2. High Beam Indicator Light 12 V 1.1 W
3. Left Turn Signal Indicator Light 12 V 1.1 W
4. Right Turn Signal Indicator Light 12 V 1.1 W
5. Neutral Indicator Light 12 V 1.1 W
6. Meter Lights 12 V 1.1 W × 3, 12 V 0.7 W × 2
7. FI Indicator Light (LED)
8. Oil Pressure Warning Indicator Light (LED)
9. Fuel Reserve Switch
10. Fuel Level Sensor
11. Water Temperature Sensor
12. Ignition Switch
13. ECU
14. Tachometer Signal
15. Oil Pressure Switch
16. Speed Sensor
17. Junction Box
18. Ignition Fuse 10 A
19. Tail Light Fuse 10 A
20. Main Fuse 30 A
21. Battery

16-70 ELECTRICAL SYSTEM

Immobilizer System (Equipped Models) (ZX1200-B3)

This motorcycle is equipped with an immobilizer system to protect the motorcycle from theft. This system provides a theft proof device by means of matching a code between the inbuilt key transponder and ECU (Electronic Control Unit). If the code does not match, ignition system, injectors and sub-throttle valve actuator will not operate and the engine will not start.

Abstract

- Do not keep more than one immobilizer key of any system on a key ring. Jamming of the key code signal may occur and the operation of the system may be affected.
- The FI indicator light illuminates for two seconds and then extinguishes when the ignition is first switched on. This shows the system is operating correctly.
- If the FI indicator light illuminates when the ignition switch is turned to the ON position and stays illuminated this shows a fault in the DFI system.
- If the FI indicator light flashes when the ignition switch is turned to the ON position this shows the immobilizer system has a fault. Refer to service code to identify the faulty component.
- The FI indicator light will flash for a period of 24 hours once the ignition switch has been switched off and the key removed. This flashing can be set to on or off as desired by holding the Mode and Reset buttons down for two seconds within twenty seconds of switching the ignition off.
- If all coded keys (master key and user keys) are lost the ECU and ignition switch will have to be replaced.
- The immobilizer system can not function until the master key code is registered in the ECU.
- A total of six keys can be registered in the ECU at any one time (one master key and five user keys).
- If the master key is lost it is not possible to register new user keys.

Operational Cautions

1. Do not put two keys of any immobilizer system on the same key ring.
2. Do not submerge any key in water.
3. Do not expose any key to excessively high temperature.
4. Do not place any key close to magnet.
5. Do not place a heavy item on any key.
6. Do not grind any key or alter its shape.
7. Do not disassemble the plastic part of any key.
8. Do not drop the key and/or apply any shocks to the key.
9. When a user key is lost, the user should go to his dealer to invalidate the lost key registration in the electronic control unit (ECU).
10. When the master key is lost, the user should go to his dealer and have a new ECU installed and register a new master key and user keys.

NOTE

○ No.9 and 10 are strongly recommended to the customer to ensure security of the motorcycle.

Key Registration

Case 1: When the user key has been lost or additional spare user key is required.

- Prepare a new spare user key.
- Cut the key in accordance with the shape of the current user key.
- Remove:
 - Rear Seat with Cover (see Frame chapter)
- Disconnect the immobilizer/Kawasaki self-diagnosis system connector [A].

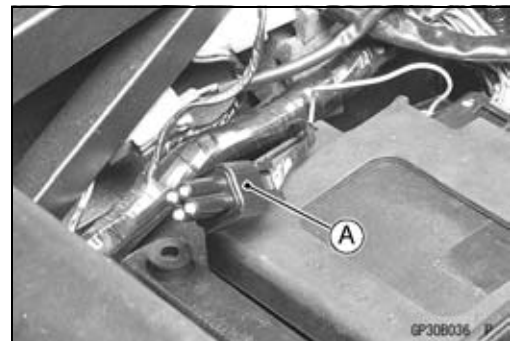

Immobilizer System (Equipped Models) (ZX1200-B3)

- Connect the key registration unit [A].
Special Tool - Key Registration Unit: 57001-1582

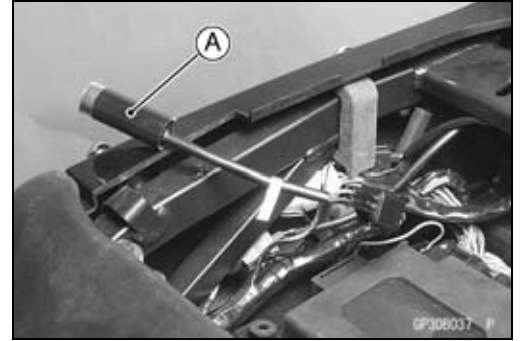

- Insert the master key to the ignition switch and turn it ON.
Verified

- The FI indicator light [A] blinks to display the registration mode (go to the next step).

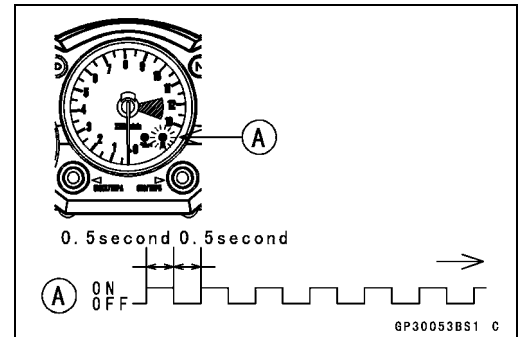

Not Verified

- The FI indicator light [A] blinks to display the collation error (refer to the following failure illustrations).
Immobilizer Amplifier Failure

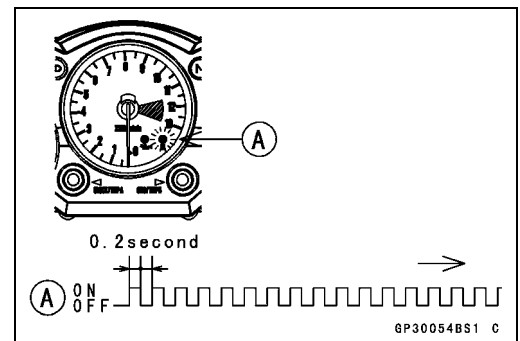

Master Key Collation Error

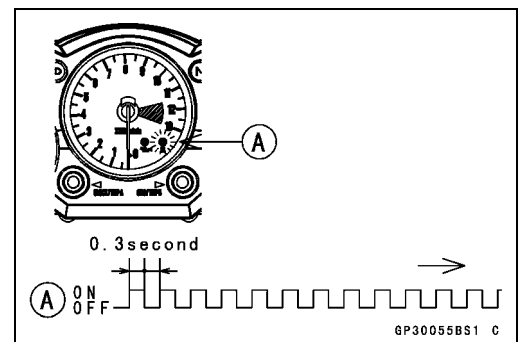

- Turn the master key OFF and remove the master key.
○ The FI indicator light [A] blinks continuously to display that the ECU is in the registration mode for 15 seconds.

NOTE

- Insert next key and turn ON within 15 seconds after previous key is turned off and removed otherwise registration mode will be ended and the FI indicator light stops flashing.
- To return to the registration mode start the master key verification procedure. This applies to all user key registration.

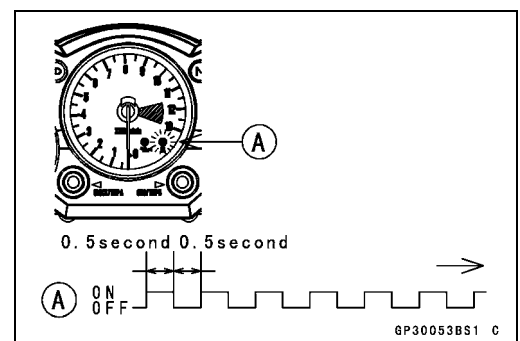

16-72 ELECTRICAL SYSTEM

Immobilizer System (Equipped Models) (ZX1200-B3)

- Insert the user key 1 to the ignition switch and turn it ON.

NOTE

○ Keep the other user key away from the immobilizer antenna.

- If there is any problem in the registration, the FI indicator light [A] blinks to display the collation error.
Immobilizer Amplifier Failure

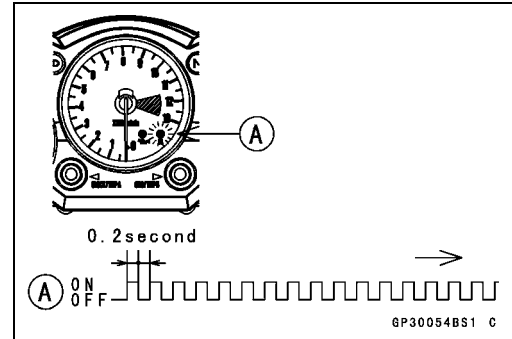

When Registered User Key is Inserted.

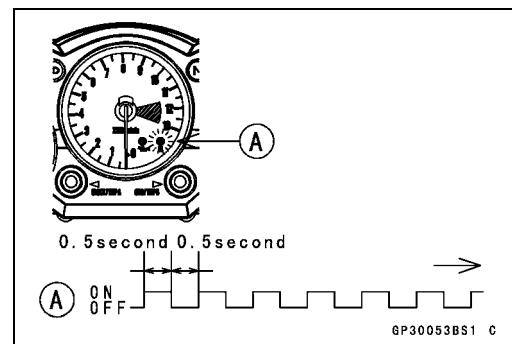

User Key Collation Error

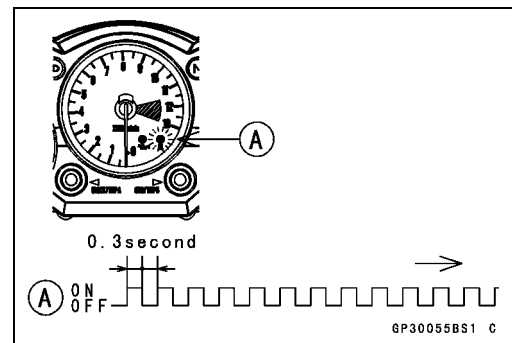

- The user key 1 is successfully registered in the ECU.
- The FI indicator light [A] blinks 2 times and stops for 1 second and then repeats this cycle.

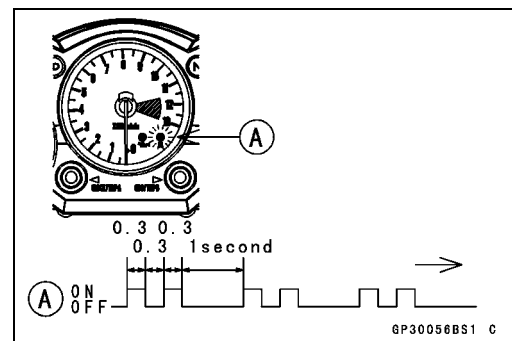

Immobilizer System (Equipped Models) (ZX1200-B3)

- Turn the user key 1 OFF and remove off the user key 1.
- The FI indicator light [A] blinks to display the registration mode.

NOTE

- Turn off the ignition switch and wait for the period of 15 seconds or more. The registration mode automatically finishes and the FI indicator light will switch off.
- This procedure registered the master key and one user key.
- Continue with the procedure to register the second and later keys before the 15 seconds period has elapsed.

- Insert the user key 2 to the ignition switch and turn it ON.

- If there is any problem in the registration, the FI indicator light [A] blinks to display the collation error.
Immobilizer Amplifier Failure

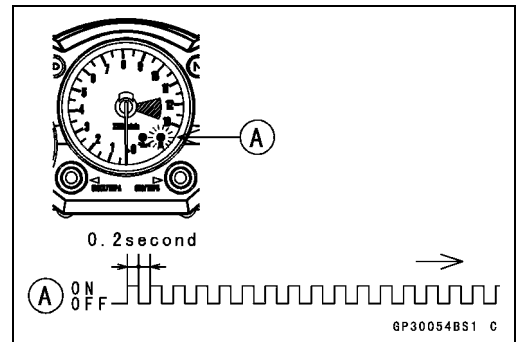
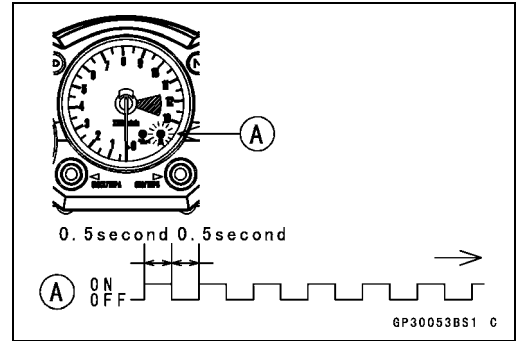

When Registered User Key is Inserted.

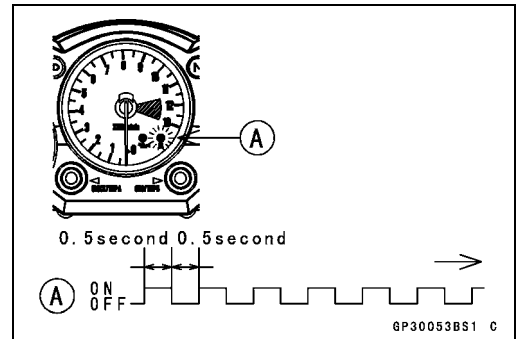

User Key Collation Error

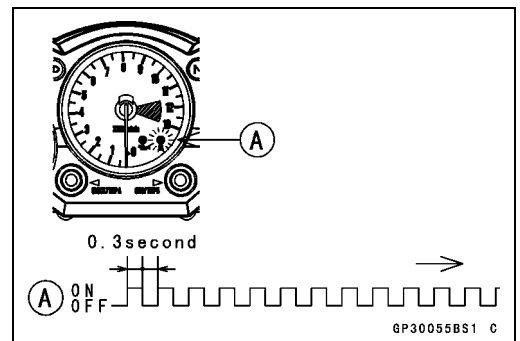

16-74 ELECTRICAL SYSTEM

Immobilizer System (Equipped Models) (ZX1200-B3)

- The user key 2 is registered in the ECU.
- The FI indicator light [A] blinks 3 times and stops for 1 second and then repeats this cycle.
- This procedure has registered the master key and 2 user keys.
- Continue with the procedure to register an additional 3 user keys.

NOTE

○ The ECU can store up the six key codes (master key × 1 and user key × 5).

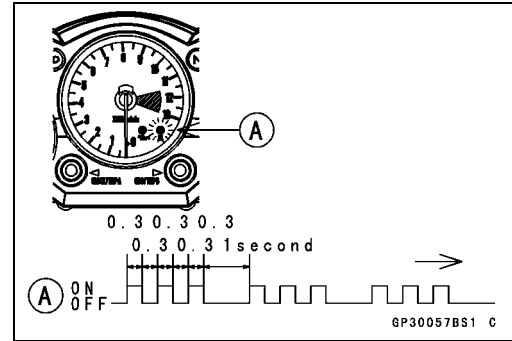

User Key Indicator Flashes

	FI Indicator Light Blinks	FI Indicator Light Stop	Remarks
User Key 3	4 times	1 seconds	Repeat
User Key 4	5 times	1 seconds	Repeat
User Key 5	6 times	1 seconds	Repeat

- Turn OFF the ignition switch and wait for period of more than 15 seconds.
- The registration mode automatically ends.
- FI indicator light goes off [A].

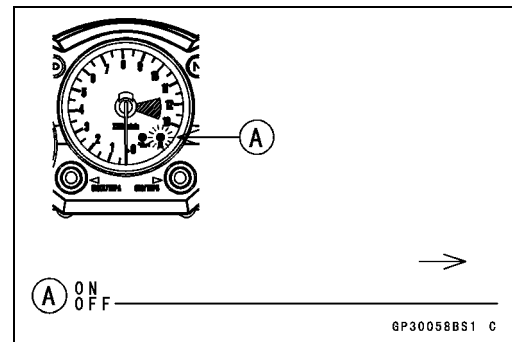

- Remove the key registration unit and connect the immobilizer Kawasaki self-diagnostic system connector.

NOTE

○ Turn the ignition switch ON with the registered user key.
 ○ Check that the engine can be started using all registered user keys.

Immobilizer System (Equipped Models) (ZX1200-B3)

Spare User Key Registration Flow Chart

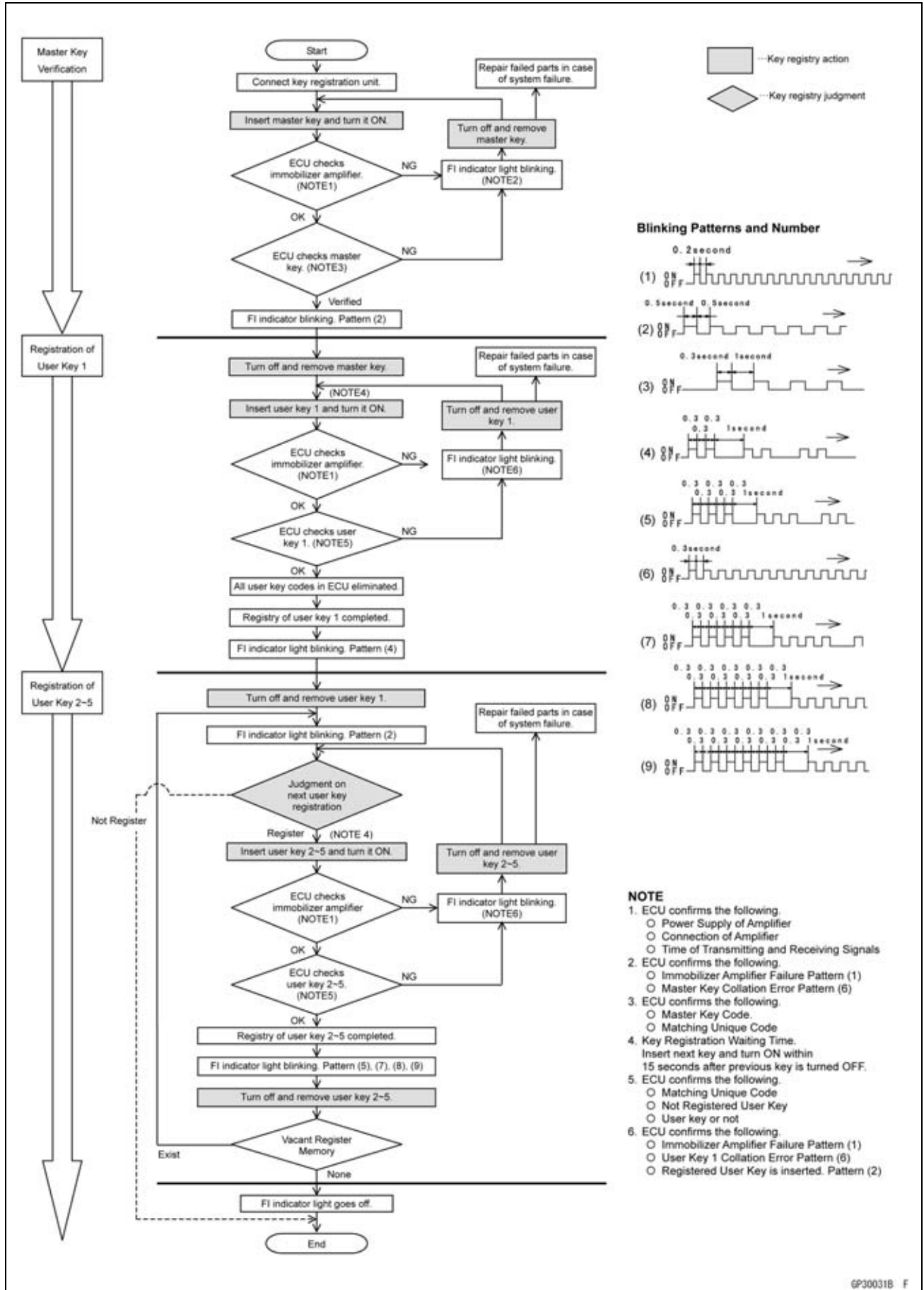

16-76 ELECTRICAL SYSTEM

Immobilizer System (Equipped Models) (ZX1200-B3)

Case 2: When the ignition switch is faulty and to be replaced.

- Prepare a new ignition switch [A] and two new user keys [B].
- These parts are available as a set. Prepare the current master key [C].

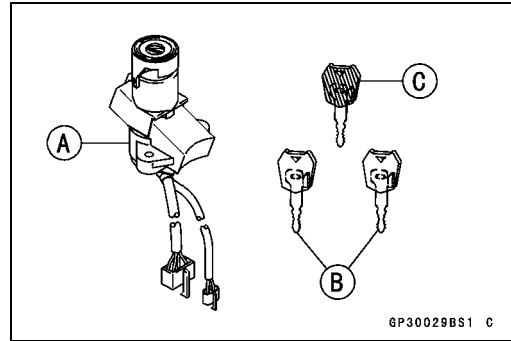

- Remove:
 - Ignition Switch and Immobilizer Antenna (see Immobilizer System Parts Replacement)
 - Rear Seat with Cover (see Frame chapter)
 - Disconnect the immobilizer/Kawasaki self-diagnostic system connector.
 - Connect the key registration unit [A].
- Special Tool - Key Registration Unit: 57001-1582**

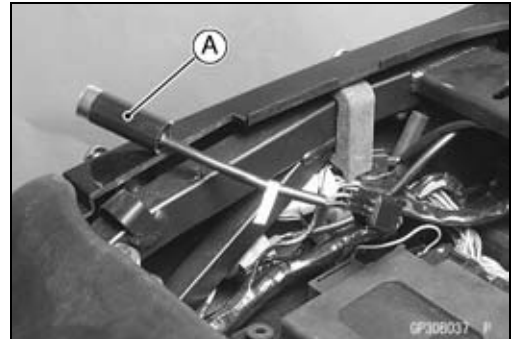

- Connect:
 - New Ignition Switch Lead Connector [A]
 - Immobilizer Antenna Lead Connector [B]

NOTE

○ Keep the antenna more than 15 cm from the ignition switch.

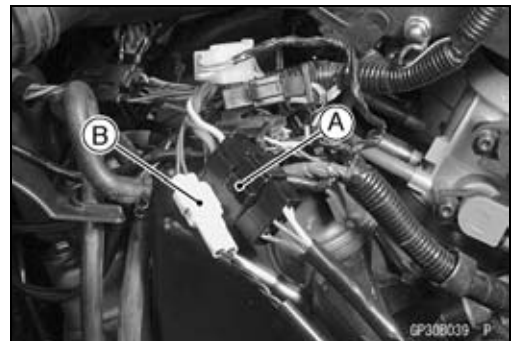

- Put the current master key [A] at the antenna [B]. Insert the new user key 1 [C] to the new ignition switch [D] and turn it ON.

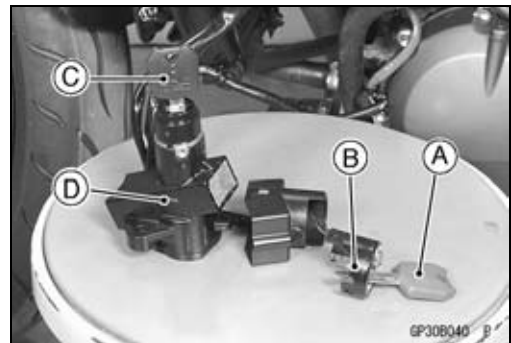

Verified

- The FI indicator light [A] blinks to display the ECU is in the registration mode (go to the next step).

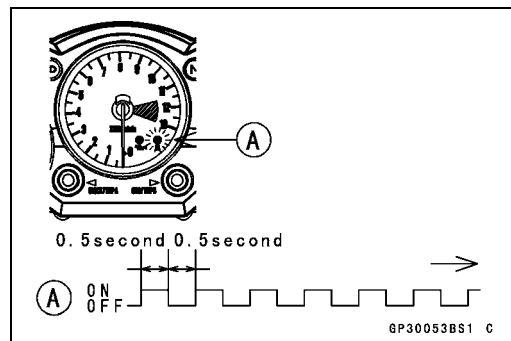

Immobilizer System (Equipped Models) (ZX1200-B3)

Not Verified

- The FI indicator light [A] blinks to display the collation error.

Immobilizer Amplifier Failure

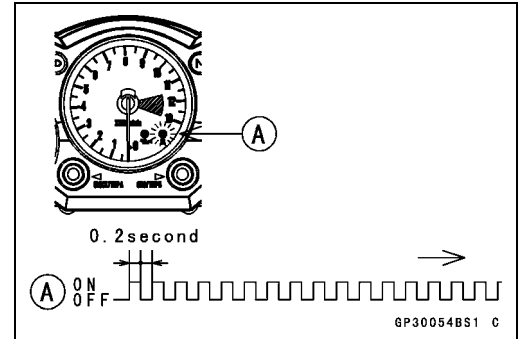

Master Key Collation Error

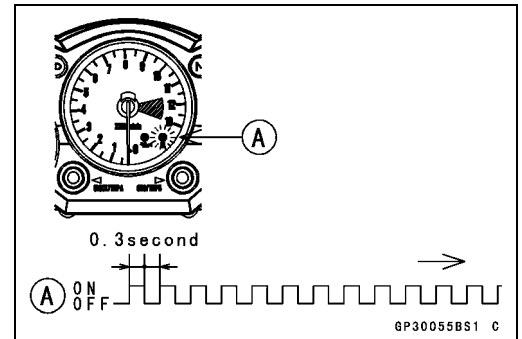

- Turn off and remove the new user key 1.
- Temporarily place the antenna [A] on the new ignition switch [B].
- Insert the user key 1 [C] again into the new ignition switch and turn it ON.

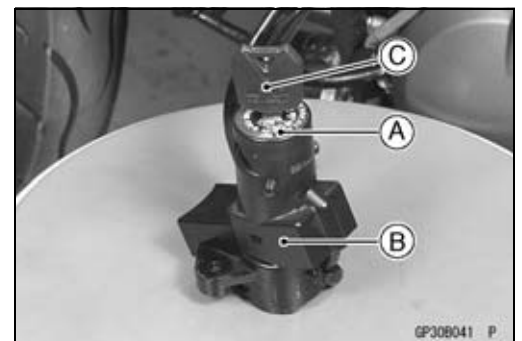

NOTE

- Place the antenna on the ignition switch, insert the next key and turn ON within 15 seconds after previous key is turned off and removed otherwise registration mode will be ended and the FI indicator light stops flashing.
 - To return to the registration mode start the master key verification procedure. This applies to all user key registration.
 - Keep other user keys away from the immobilizer antenna.
- If there is any problem in the registration, the FI indicator light [A] blinks to display the collation error.
- Immobilizer Amplifier Failure

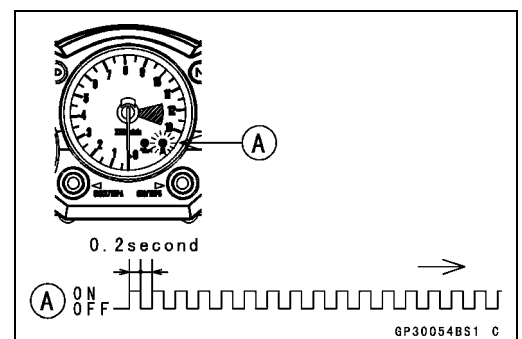

16-78 ELECTRICAL SYSTEM

Immobilizer System (Equipped Models) (ZX1200-B3)

When Registered User Key is Inserted.

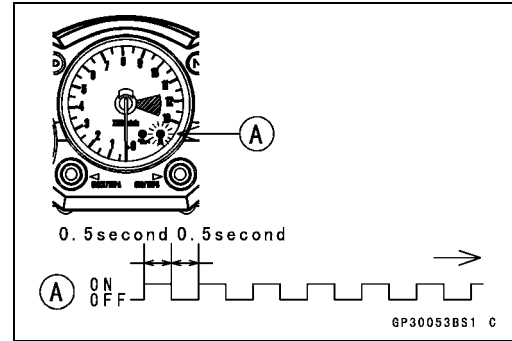

User Key Collation Error

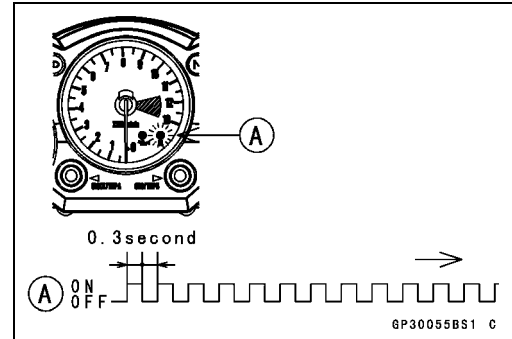

- The user key 1 is successfully registered in the ECU.
- The FI indicator light [A] blinks 2 times and stops for 1 second and then repeats this cycle to indicate successful registering of user key 1.

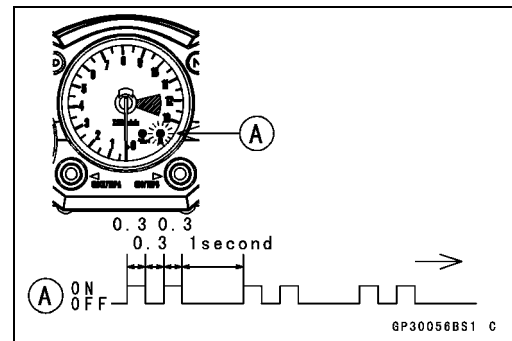

- Turn off and remove user key 1.
- The FI indicator light [A] blinks to display the registration mode.

NOTE

- Turn off the ignition switch and wait for the period more than 15 seconds. The registration mode automatically ends and FI indicator light goes off.
 - This procedure has , registered the master key and one user key.
 - Continue the procedure to program the second and later keys.
- Insert the user key 2 to the ignition switch and turn it ON.

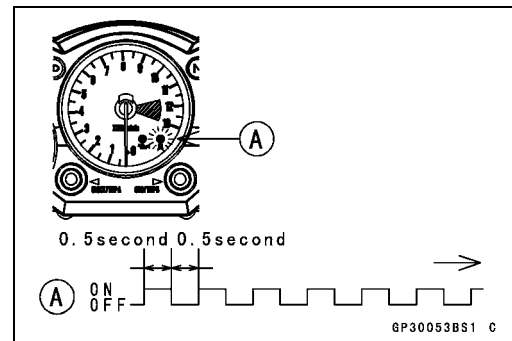

Immobilizer System (Equipped Models) (ZX1200-B3)

○If there is any problem in the registration, the FI indicator light [A] blinks to display the collation error.
Immobilizer Amplifier Failure

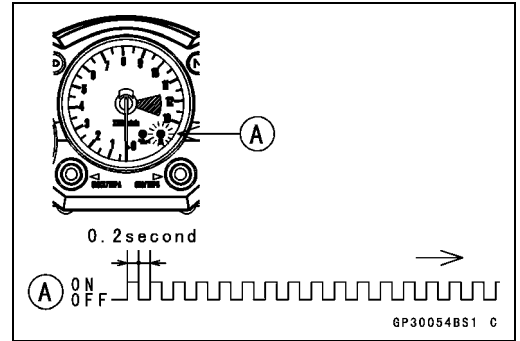

When Registered User Key is Inserted.

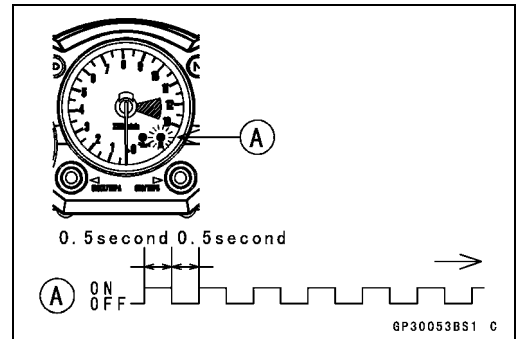

User Key Collation Error

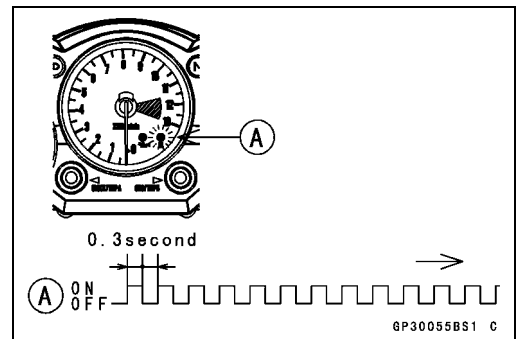

- The user key 2 is successfully registered in the ECU.
- The FI indicator light [A] blinks 3 times and stops for 1 second and then repeat this cycle to indicate successful programming of user key 2.
- Turn OFF the ignition switch and wait for period more than 15 seconds.
- The registration mode automatically ends.

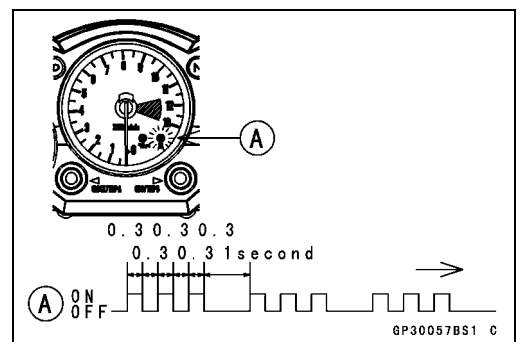

- FI indicator light goes off [A].

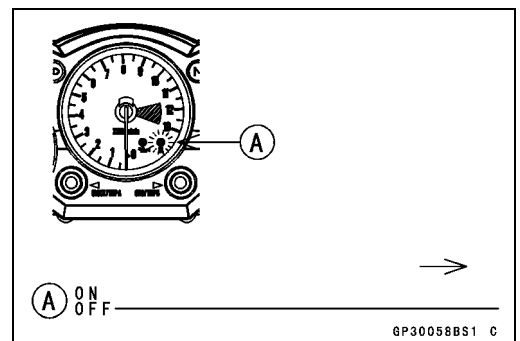

16-80 ELECTRICAL SYSTEM

Immobilizer System (Equipped Models) (ZX1200-B3)

- Remove the key registration unit and connect the immobilizer/Kawasaki self-diagnostic system connector.

NOTE

- Turn the ignition switch ON with the registered user key.
- Check that the engine can be started using all registered user keys.

- Install the new ignition switch and antenna.

Case 3: When the electric control unit (ECU) is faulty and has to be replaced.

- Prepare a new ECU [A], current master key [B] and current user keys [C].

NOTE

- The key registration unit is not required.

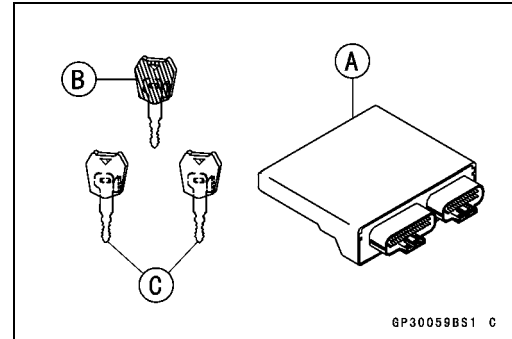

- Replace:
ECU [A] (see Immobilizer System Parts Replacement)



- Insert the current master key into the ignition switch and turn it ON.

- If there is any problem in the registration, the FI indicator light [A] blinks to display the collation error.
Immobilizer Amplifier Failure

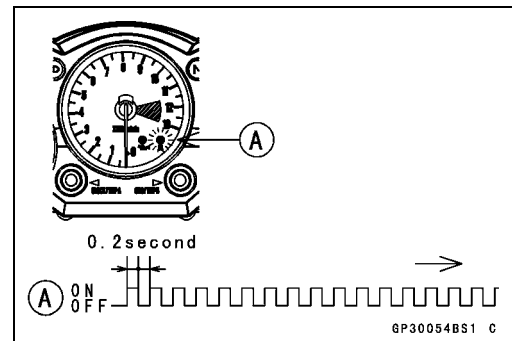

Master Key Collation Error

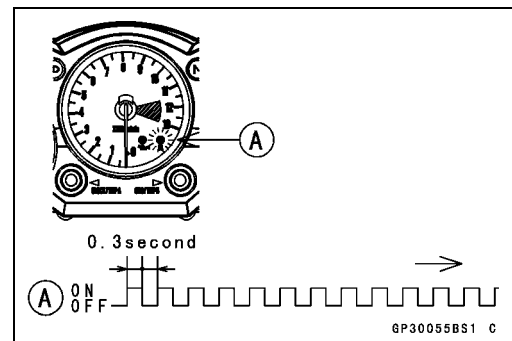

Immobilizer System (Equipped Models) (ZX1200-B3)

- The master key is registered in the ECU.
- The FI indicator light [A] blinks 1 time and stops for 1 second and the repeats this cycle to indicate successful registration of the master key.

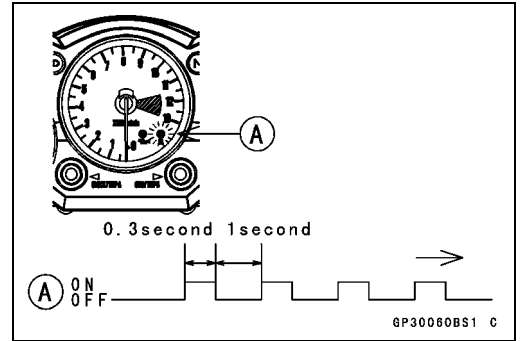

- Turn of the master key and remove it.
- The FI indicator light [A] blinks to display the registration mode.

NOTE

- Insert next key and turn ON within 15 seconds after previous key is turned off and removed otherwise registration mode will be ended and the FI indicator light goes off.
- To return to the registration mode start the master key verification procedure. This applies to all user key registration.

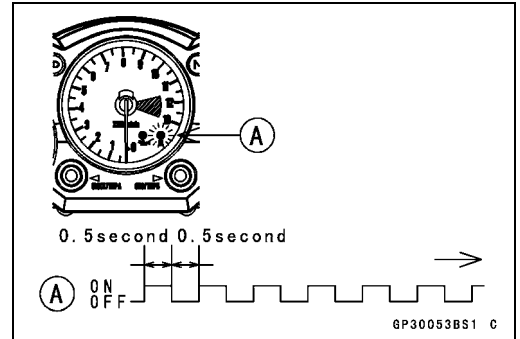

- Insert the user key 1 to the ignition switch and turn it ON.

NOTE

- Keep the other user keys away from the immobilizer antenna.
- If there is any problem in the registration, the FI indicator light [A] blinks to display the collation error. Immobilizer Amplifier Failure

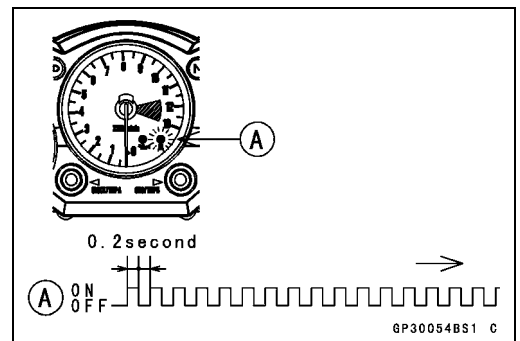

When Registered User Key is Inserted.

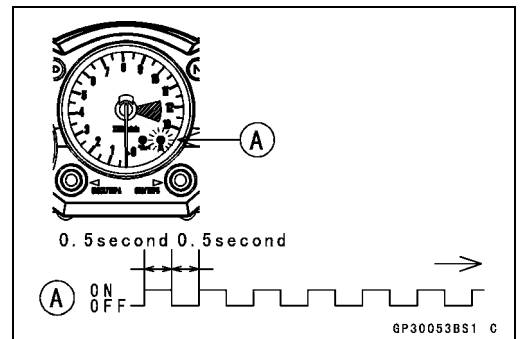

16-82 ELECTRICAL SYSTEM

Immobilizer System (Equipped Models) (ZX1200-B3)

User Key Collation Error

- The user key 1 is registered in the ECU.
- The FI indicator light [A] blinks 2 times and stops for 1 second and then repeats this cycle to indicate successful registration of user key.

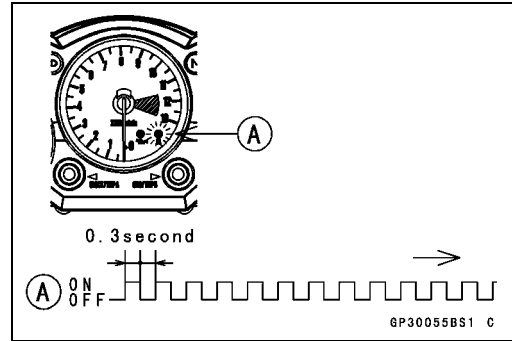

- Turn off and remove the user key 1.
- The FI indicator light [A] blinks to display the registration mode codes.

NOTE

- Insert next key and turn ON within 15 seconds after previous key is turned off and removed otherwise registration mode will be ended and the FI indicator light goes off.
 - To return to the registration mode start the master key verification procedure. This applies to all user key registration.
- Insert the user key 2 to the ignition switch and turn it ON.
 - If there is any problem in the registration, the FI indicator light [A] blinks to display the collation error code.
Immobilizer Amplifier Failure

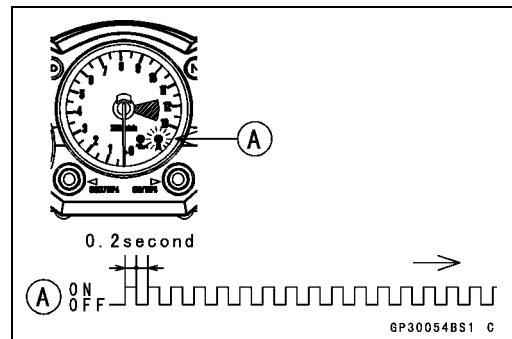
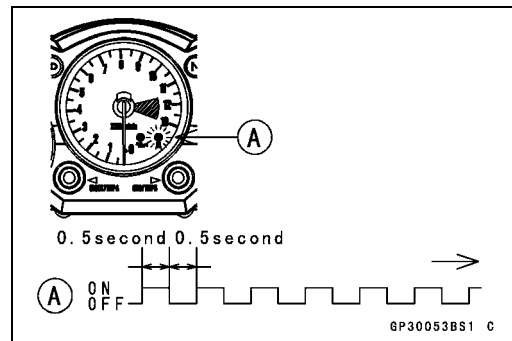
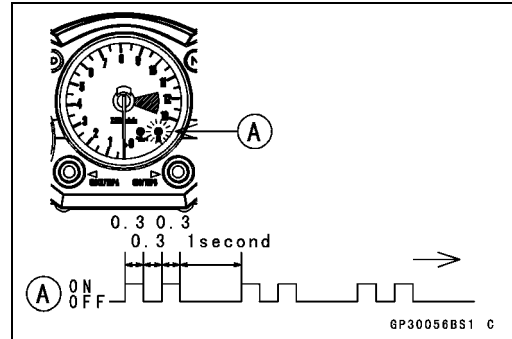

Immobilizer System (Equipped Models) (ZX1200-B3)

When Registered User Key is Inserted.

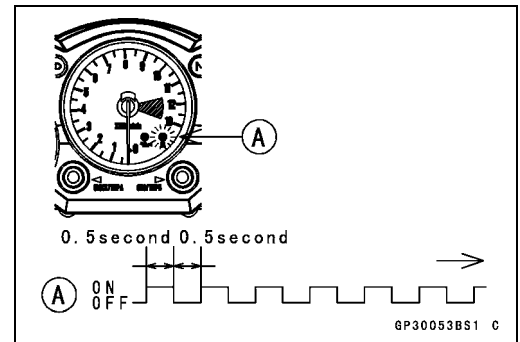

User Key Collation Error

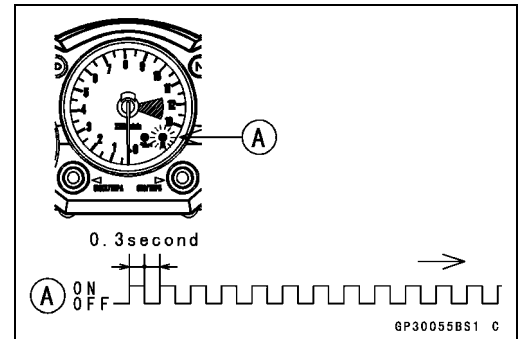

- The user key 2 is registered in the ECU.
- The FI indicator light [A] blinks 3 times and stops for 1 second and then repeats this cycle to indicate successful registration of user key 2.
- Turn OFF the ignition switch and wait for period more than 15 seconds.
- The registration mode automatically ends.

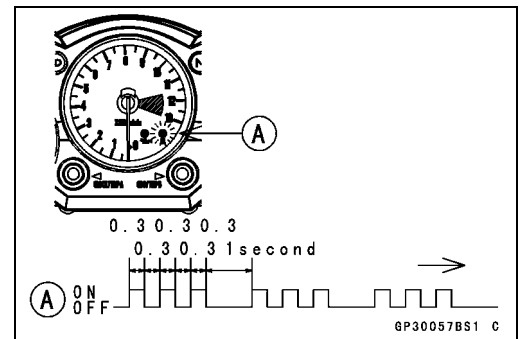

- FI indicator light goes off [A].

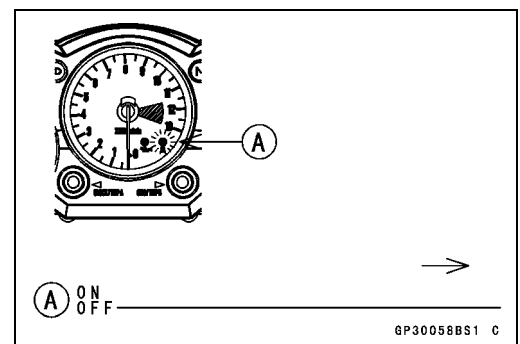

NOTE

- Turn the ignition switch ON with the registered user key.
- Check that the engine can be started using all registered user keys.

Case 4: When master key is faulty or lost.

The master key replacement is considered very rare case. However if it is required, the following is necessary.

NOTE

- The ECU must be replaced with a new one because the master key code that is registered in the current ECU can not be rewritten.

16-84 ELECTRICAL SYSTEM

Immobilizer System (Equipped Models) (ZX1200-B3)

- Prepare a new ECU [A], new master key [B] and current user keys [C].

NOTE

- *The key registration unit is not required.*
- *The key registration process is same as the electric control unit replacement.*

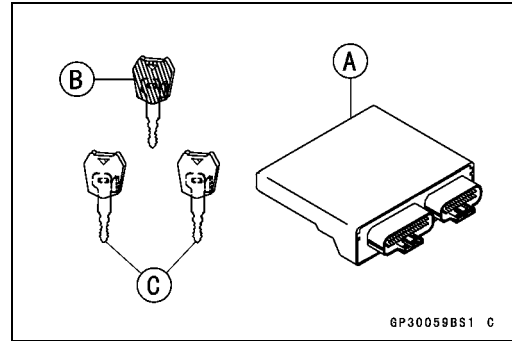

Case 5: When replacing the antenna.

- Prepare a new antenna.
- Refer to the Immobilizer System Parts Replacement.

NOTE

- *No key registration is required.*

Immobilizer System (Equipped Models) (ZX1200-B3)

All Keys Initial Registration Flow Chart

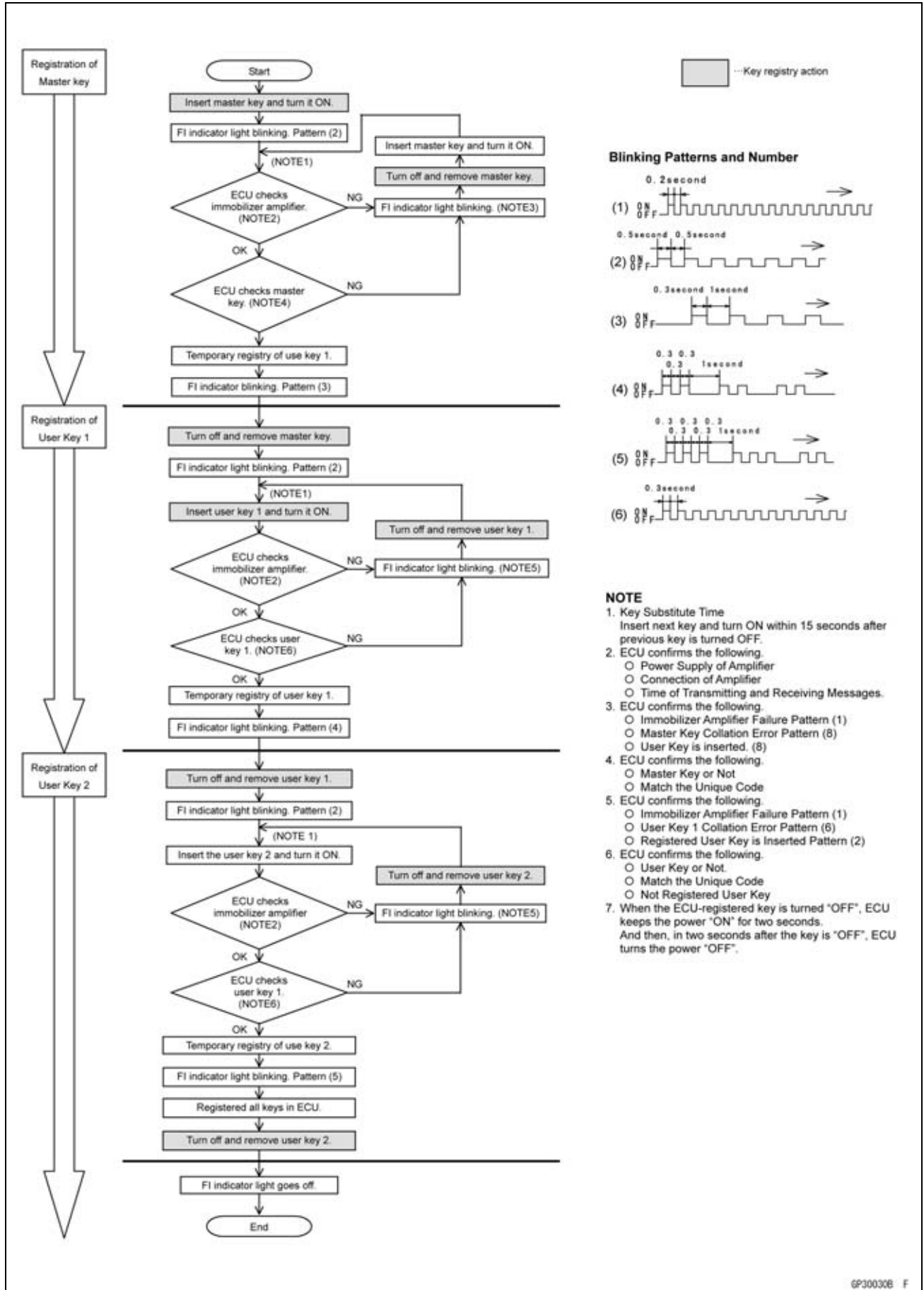

16-86 ELECTRICAL SYSTEM

Immobilizer System (Equipped Models) (ZX1200-B3)

Immobilizer System Parts Replacement

Immobilizer Antenna

- Remove:
 - Left Lower Inner Cover (see Frame chapter)
- Disconnect the lead connectors [A].

- Remove:
 - Steering Stem Head (see Steering chapter)
 - Handlebar (see Steering chapter)
- Using a small chisel [A] or punch, turn out the Torx bolts.

- Cut the band [A].
- Remove the screw [B].
- Remove the antenna [C] with the cover [D].
- Pull the lower parts [E] of the cover outside to clear the projection [F] of the ignition switch.

- Tighten a new Torx bolt [A] until the bolt head [B] is broken [C].
- Run the leads correctly (see General Information chapter).

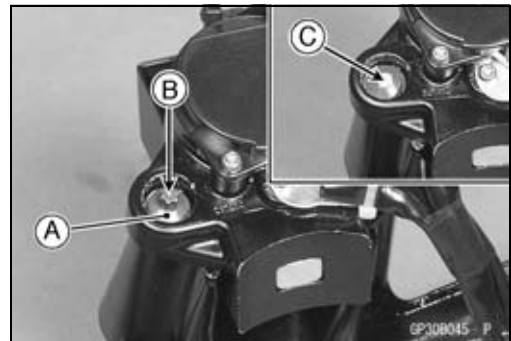
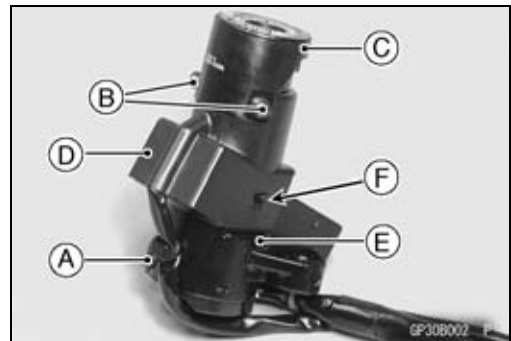

Immobilizer Amplifier Replacement

- Remove:
 - Upper Fairing (see Frame chapter)
- Disconnect the connector [A].
- Remove the amplifier [B] from the bracket [C].

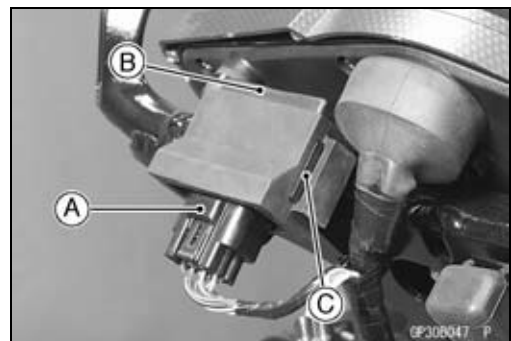

Immobilizer System (Equipped Models) (ZX1200-B3)

ECU (Electric Control Unit) Replacement (for European Model)

- Remove:
Rear Seat with Cover (see Frame chapter)
- Remove the screws [A] and upper guard bracket [B].

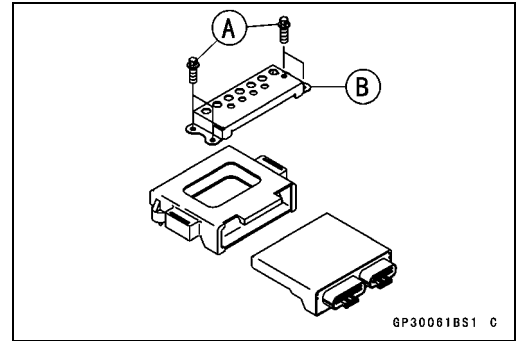

- Remove:
ECU [A]
- Disconnect the connectors [B] and remove the under guard bracket.

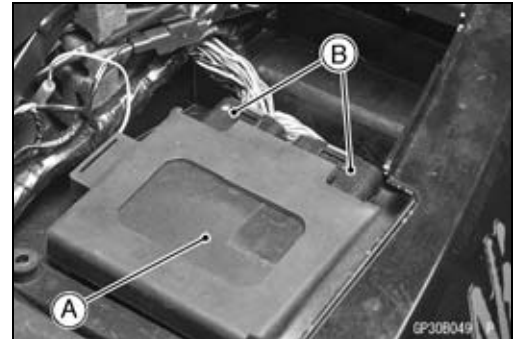

- Set the connectors [A] to the under guard bracket.
- Install the under guard bracket to the ECU.
- Connect the connectors.

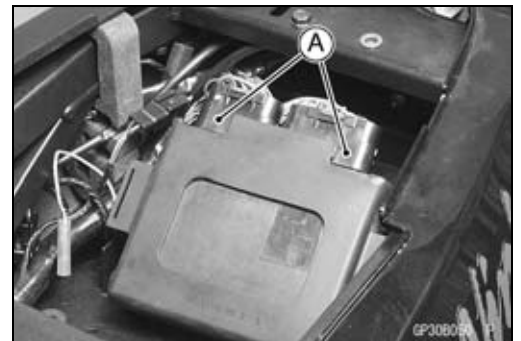

- Install:
Upper Guard Bracket [A]

CAUTION

Do not pinch the leads.

- Apply a non-permanent locking agent to the threads and tighten the screws [B].

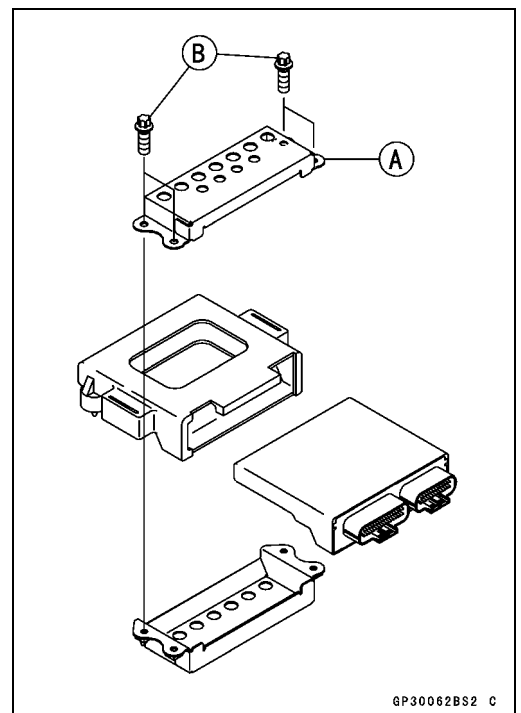

16-88 ELECTRICAL SYSTEM

Immobilizer System (Equipped Models) (ZX1200-B3)

Immobilizer Relational Parts Replacement Chart

		Failed or Lost Part					
		Master Key (Red)	User Key (Black)	Ignition Switch	Antenna	Amplifier	ECU
*	Master Key (Red)	●					
	User Key (Black)		●	○			
	Ignition Switch			●			
	Antenna				●		
	Amplifier					●	
	ECU						●

*	Replacement Part
●	Main Replacement Part
○	Additional Replacement Part

Immobilizer System Inspection

- Refer to the Immobilizer Amplifier and Blank Key Detection section in the Fuel System (DFI) chapter.

Immobilizer System Circuit

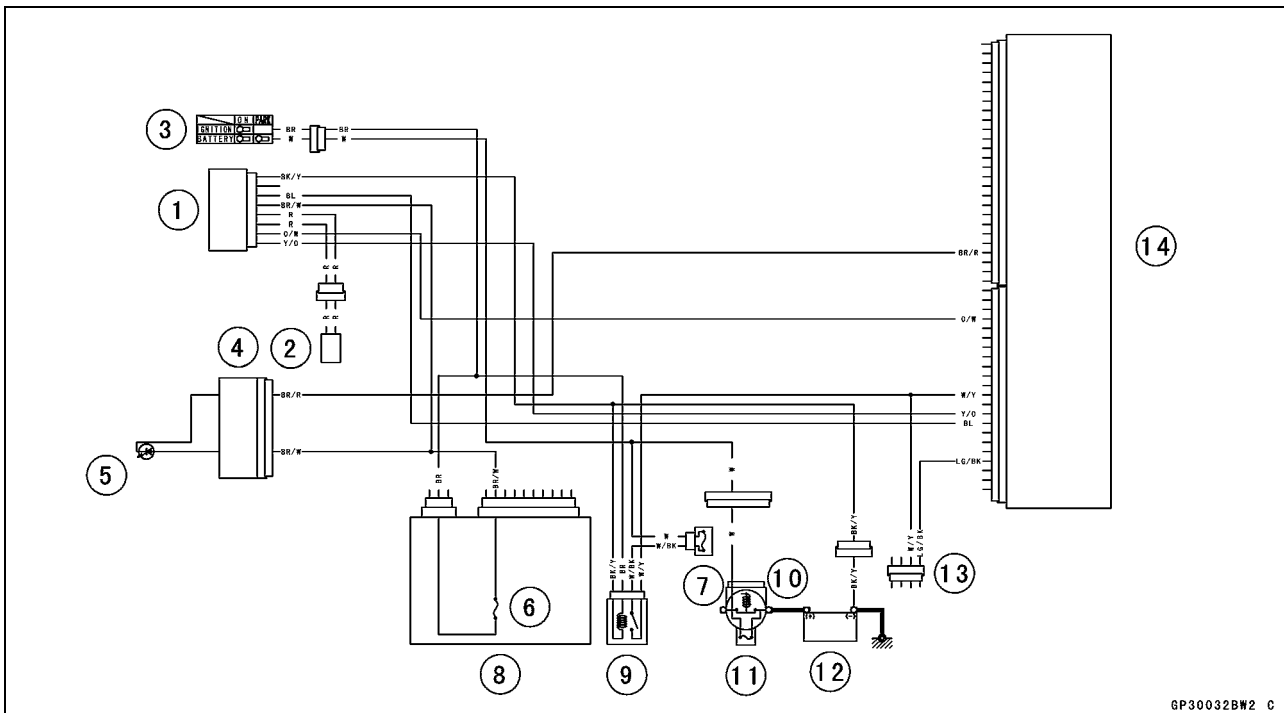

GP30032BW2 C

- | | | |
|--------------------------|------------------------|--|
| 1. Immobilizer Amplifier | 7. ECU Fuse 15 A | 13. Immobilizer/Kawasaki Diagnostic System Connector |
| 2. Immobilizer Antenna | 8. Junction Box | 14. Electronic Control Unit (ECU) |
| 3. Ignition Switch | 9. ECU Main Relay | |
| 4. Meter Unit | 10. Starter Relay | |
| 5. FI Indicator Light | 11. Main Fuse 30 A | |
| 6. Ignition Fuse 10 A | 12. Battery 12 V 12 Ah | |

Switches and Sensors

Front Brake Light Switch Inspection

- Refer to the Front Brake Light Switch Inspection in the Periodic Maintenance chapter.

Rear Brake Light Switch Check/Adjustment

- Refer to the Rear Brake Light Switch Inspection/Adjustment in the Periodic Maintenance chapter.

Switch Inspection

- Using a hand tester, check to see that only the connections shown in the table have continuity (about zero ohms).
- For the switch housing and the ignition switch, refer to the tables in the Wiring Diagram.
- ★ If the switch has an open or short, repair it or replace it with a new one.

Special Tool - Hand Tester: 57001-1394

Rear Brake Light Switch Connections

	BR	BL
When brake pedal is pushed down		
When brake pedal is released		

Side Stand Switch Connections

	G	BK
When side stand is up		
When side stand is down		

Gear Position Switch Connections

	Color	
When transmission is in 1st	BL/R	
When transmission is in neutral	LG	
When transmission is in 2nd	LB	
When transmission is in 3rd	R	
When transmission is in 4th	BL	
When transmission is in 5th	G/R	
When transmission is in 6th	Y/G	

Engine Oil Pressure Switch Connections*

	SW. Terminal	
When engine is stopped		
When engine is running		

*: Engine lubrication system is in good condition

16-90 ELECTRICAL SYSTEM

Switches and Sensors

Radiator Fan Switch Inspection

- Remove the fan switch (see Cooling System chapter).
- Suspend the switch [A] in a container of coolant so that the temperature-sensing projection [C] and threaded portion [C] are submerged.
- Suspend an accurate thermometer [B] in the coolant.

NOTE

○ The switch and thermometer must not touch the container sides or bottom.

- Place the container over a source of heat and gradually raise the temperature of the coolant while stirring the coolant gently.
 - Using the hand tester, measure the internal resistance of the switch across the terminals at the temperatures shown in the table.
- ★ If the hand tester does not show the specified values, replace the switch.

Fan Switch Resistance

Rising temperature:

From OFF to ON at 93 ~ 103°C (199 ~ 217°F)

Falling temperature:

Fan stops with the temperature 3 ~ 8°C (38 ~ 46°F) lower than the operation temperature range.

ON: Less than 0.5 Ω

OFF: More than 10 MΩ

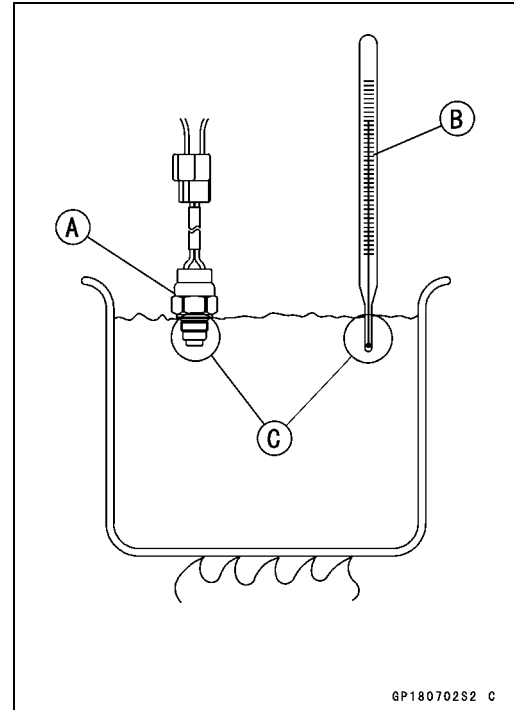

Switches and Sensors

Water Temperature Sensor Inspection

- Remove the water temperature sensor (see Fuel System (DFI) chapter).
- Suspend the sensor [A] in a container of coolant so that the temperature-sensing projection [E] and threaded portion [E] are submerged.
- Suspend an accurate thermometer [B] in the coolant.

NOTE

- The sensor and thermometer must not touch the container side or bottom.
- Place the container over a source of heat and gradually raise the temperature of the coolant while stirring the coolant gently.
- Using the hand tester, measure the internal resistance of the sensor.
- The sensor sends electric signals to the ECU (Electronic Control Unit) and coolant temperature gauge in the meter unit.
- Measure the resistance across the terminals and the body (for the gauge) at the temperatures shown in the table.
- ★ If the hand tester does not show the specified values, replace the sensor.

Water Temperature Sensor

Resistance for ECU [C]	
Temperature	Resistance (kΩ) (Terminal [1] - [3])
20°C (68°F)	2.45 \pm 0.14 -0.13
80°C (176°F)	0.318 \pm 0.008
110°C (230°F)	0.1417 \pm 0.0018

Resistance for Water Temperature Gauge [D]	
Temperature	Resistance (kΩ) (Terminal [2] - Body)
50°C (122°F)	7.115 \pm 0.285
80°C (176°F)	2.37 \pm 0.237
120°C (248°F)	0.69 \pm 0.41

Speed Sensor Removal

- Remove:
 - Lower Fairing (see Frame chapter)
 - Engine Sprocket Cover (see Final Drive chapter)
 - Speed Sensor Lead Connector [A]
 - Clamp [B]

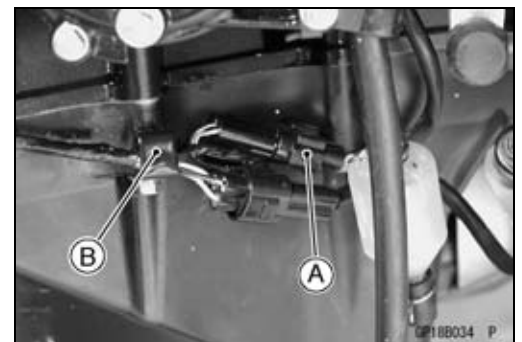
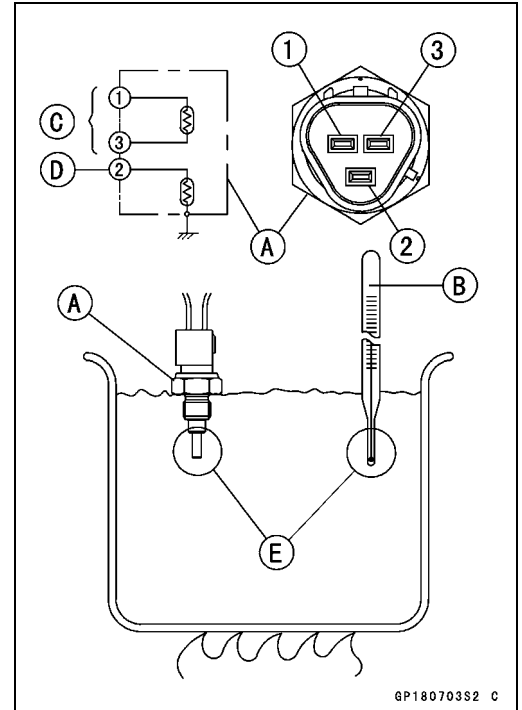

16-92 ELECTRICAL SYSTEM

Switches and Sensors

- Remove:
 - Speed Sensor Mounting Bolt [A]
 - Speed Sensor [B]

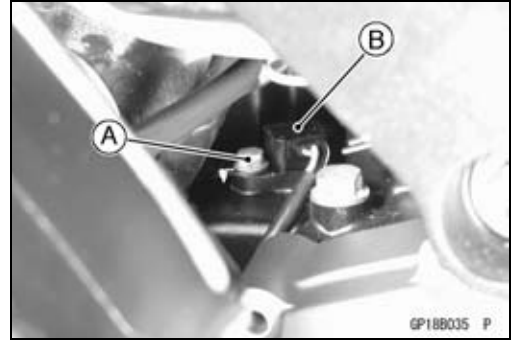

Speed Sensor Installation

- Apply grease or engine oil to the O-ring [A] on the speed sensor.
- Tighten:
 - Torque - Speed Sensor Mounting Bolt: 10 N·m (1.0 kgf·m, 89 in·lb)**



Speed Sensor Inspection

- Remove:
 - Speed Sensor (see Speed Sensor Removal)
- Connect the speed sensor connector [A] with a battery [B], 10 kΩ resistor [C] and hand tester [D] as shown.
- Set the tester to the DC 25 V range.
- Special Tool - Hand Tester: 57001-1394**

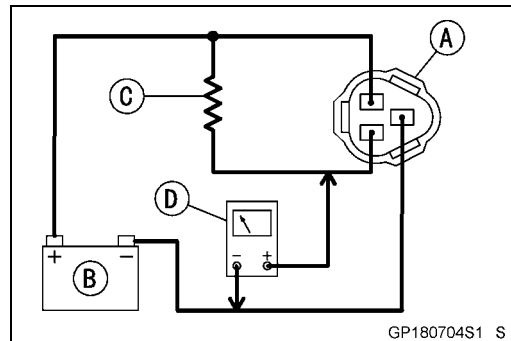

- Trace [A] the speed sensor surface with the screw driver.
- Then the tester indicator should flick [B].
- ★ If the tester indicator does not flick, replace the speed sensor.

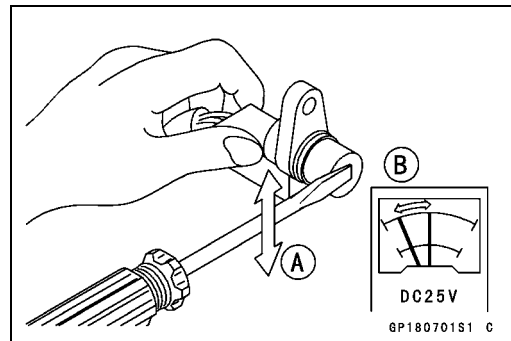

Fuel Level Sensor Inspection

- Remove:
 - Fuel Tank (see Fuel System (DFI) chapter)
 - Fuel Level Sensor Lead Connector [A]
- Push the stopper [B] upward [C] and pull out the connector.

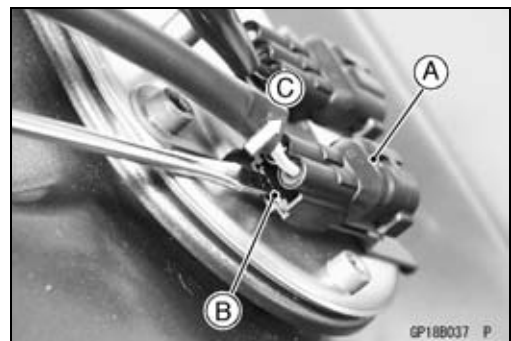

Switches and Sensors

- Remove:
 - Bolts [A]
 - Fuel Level Sensor [B]

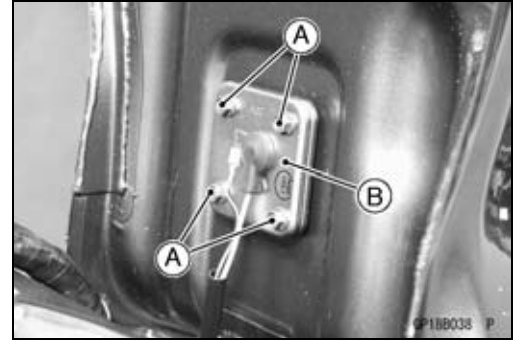

- Check that the float moves up and down smoothly without binding. It should go down under its own weight.
- ★ If the float does not move smoothly, replace the sensor.
 - Float in Full Position [A]
 - Float in Empty Position [B]
 - Float Arm Stoppers [C]
- Using the hand tester, measure the resistance across the terminals in the fuel level sensor lead connector [D].

Special Tool - Hand Tester: 57001-1394

- ★ If the tester readings are not as specified, or do not change smoothly according as the float moves up and down, replace the sensor.

Fuel Level Sensor Resistance

Standard: **Full position: 8 ~ 10 Ω**
 Empty position: 122 ~ 126 Ω

- Apply a non-permanent locking agent to the threads of the level sensor mounting bolts and tighten it.
- Torque - Fuel Level Sensor Bolts: 6.9 N·m (0.70 kgf·m, 61 in·lb)**

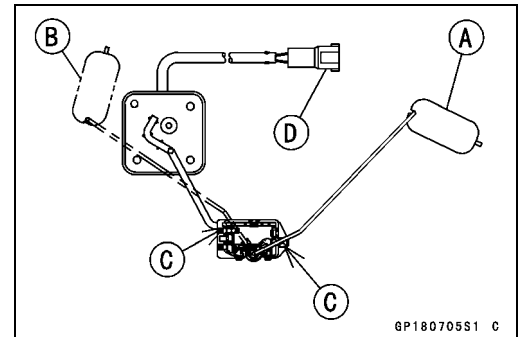

Fuel Reserve Switch Inspection (1)

- Fill the fuel tank with fuel.
- Close the fuel tank cap surely.
- Remove the fuel tank (see Fuel System (DFI) chapter).
- Connect the test light [A] (12 V 3.4 W bulb a socket with leads) and the 12 V battery [B] to the fuel pump connector [C].

Connections:

Battery (+) → 12 V 3.4 W Bulb (one side)
 12 V 3.4 W Bulb (other side) → R/BK Lead Terminal
 Battery (-) → BK/W Lead Terminal

Special Tool - Needle Adapter Set: 57001-1457

- ★ If the test light turn on, the reverse switch is defective. Replace the fuel pump.

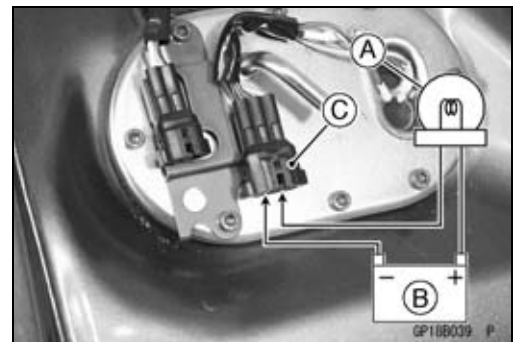

16-94 ELECTRICAL SYSTEM

Switches and Sensors

Fuel Reserve Switch Inspection (2)

- Remove:
 - Fuel Pump (see Fuel System (DFI) chapter)
- Connect the test light (12 V 3.4 W bulb in a socket with leads) and the 12 V battery to the fuel pump connector as shown.
 - 12 V Battery [A]
 - Test Light [B]
 - Fuel Pump Connector [C]
 - Fuel Reserve Switch [D]

★ If the test light doesn't light, replace the fuel pump.

NOTE

○ It may take a long time to turn on the test light in case that the fuel reserve switch is inspected just after the fuel pump is removed. Leave the fuel reserve switch with leads for inspection connected for one (1) minute.

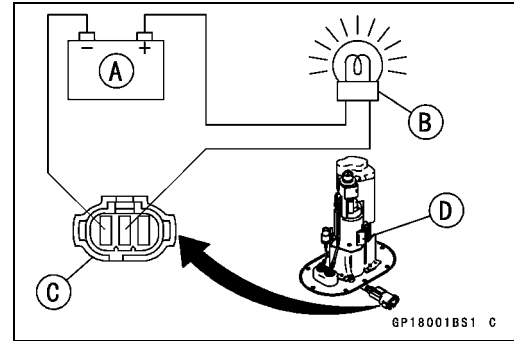

Junction Box

The junction box [A] has fuses [B], relays, and diodes. The relays and diodes can not be removed.

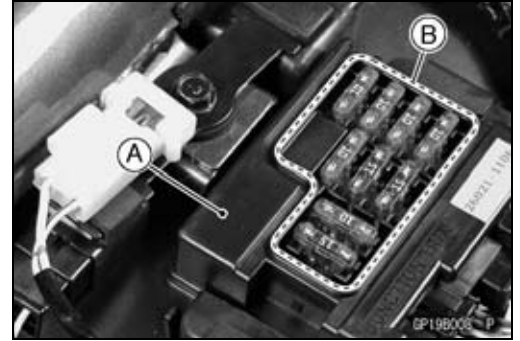

Junction Box Fuse Circuit Inspection

- Remove:
 - Fuel Tank Cover (see Fuel System (DFI) chapter)
 - Rubber Cover
 - Connectors
 - Junction Box
- Make sure all connector terminals are clean and tight, and none of them have been bent.
- ★ Clean the dirty terminals, and straighten slightly-bent terminals.
- Check conductivity of the numbered terminals with the hand tester.
- ★ If the tester does not read as specified, replace the junction box.

Fuse Circuit Inspection

Tester Connection	Tester Reading (Ω)
1 - 1A	0
1 - 2	0
3A - 4	0
6 - 5	0
6 - 10	0
6 - 7	0
6 - 17	0

Tester Connection	Tester Reading (Ω)
1A - 8	∞
2 - 8	∞
3A - 8	∞
6 - 2	∞
6 - 3A	∞
17 - 3A	∞

Starter Circuit/Headlight Relay Inspection

- Remove the junction box.
- Check conductivity of the following numbered terminals by connecting the hand tester and one 12 V battery to the junction box as shown.
- ★ If the tester does not read as specified, replace the junction box.

16-96 ELECTRICAL SYSTEM

Junction Box

Relay Circuit Inspection (with the battery disconnected)

	Tester Connection	Tester Reading (Ω)		Tester Connection	Tester Reading (Ω)
Head-light Relay	*7 - 8	∞	Starter Circuit Relay	9 - 11	∞
	*7 - 13	∞		12 - 13	∞
	(+) (-) *13 - 9	Not ∞ **		(+) (-) 13 - 11	∞
		(+) (-) 12 - 11		Not ∞ **	

*: U.S.A, Canadian, Australian, and Malaysian Models only

** : The actual reading varies with the hand tester used.

(+): Apply tester positive lead.

(-): Apply tester negative lead.

Relay Circuit Inspection (with the battery connected)

	Battery Connection (+) (-)	Tester Connection	Tester Reading (Ω)
Headlight Relay	*9 - 13	*7 - 8	0
Starter Circuit Relay	11 - 12	(+) (-) 13 - 11	Not ∞ **

*: U.S.A., Canadian, Australian, and Malaysian Models only

** : The actual reading varies with the hand tester used.

(+): Apply tester positive lead.

(-): Apply tester negative lead.

Diode Circuit Inspection

- Remove the junction box.
- Check conductivity of the following pairs of terminals.

Diode Circuit Inspection

Tester Connection	*13-8, *13-9, 12-11, 12-14, 15-14, 16-14
-------------------	---

*: U.S.A., Canadian, Australian, and Malaysian Models only

- ★ The resistance should be low in one direction and more than ten times as much in the other direction. If any diode shows low or high in both directions, the diode is defective and the junction box must be replaced.

NOTE

○ The actual meter reading varies with the meter used and the individual diodes, but, generally speaking, the lower reading should be from zero to one half the scale.

Junction Box

Junction Box Internal Circuit (U.S.A., Canadian, Australian, and Malaysian/ZX1200-B2/B3 Models)

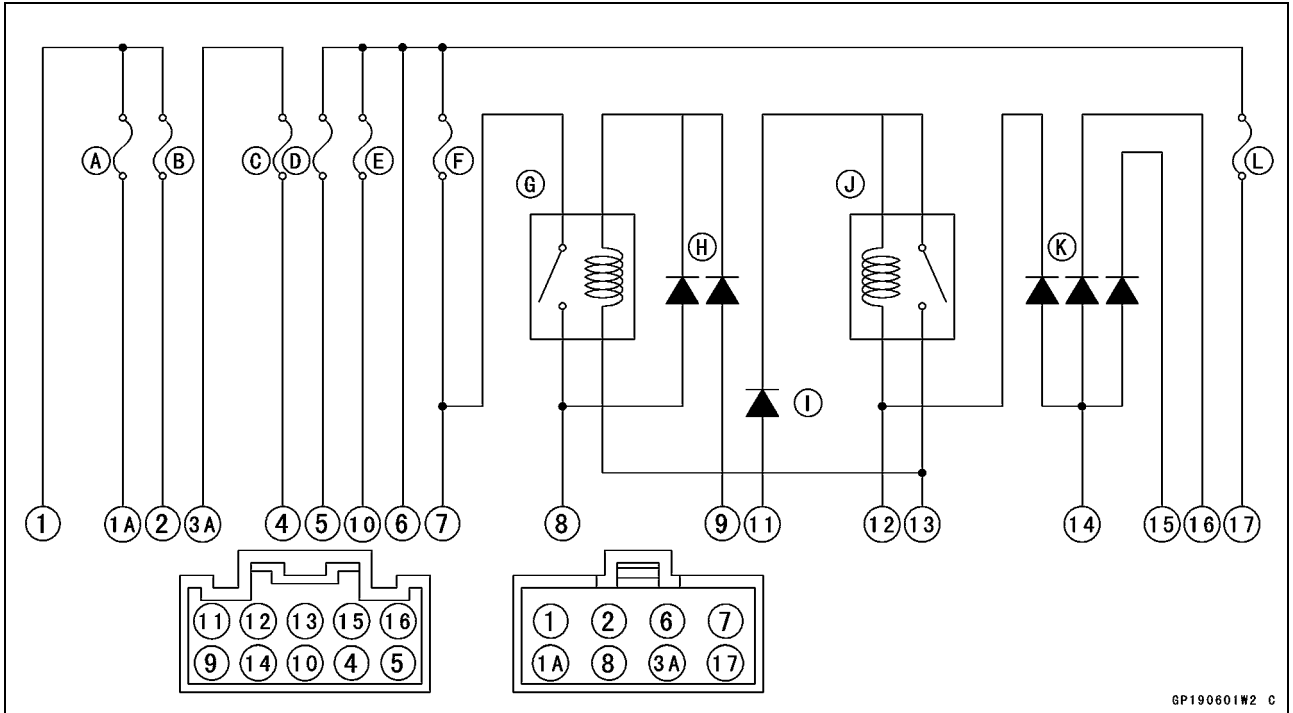

GP190601W2 C

Junction Box Internal Circuit (Other than U.S.A., Canadian, Australian, and Malaysian Models)

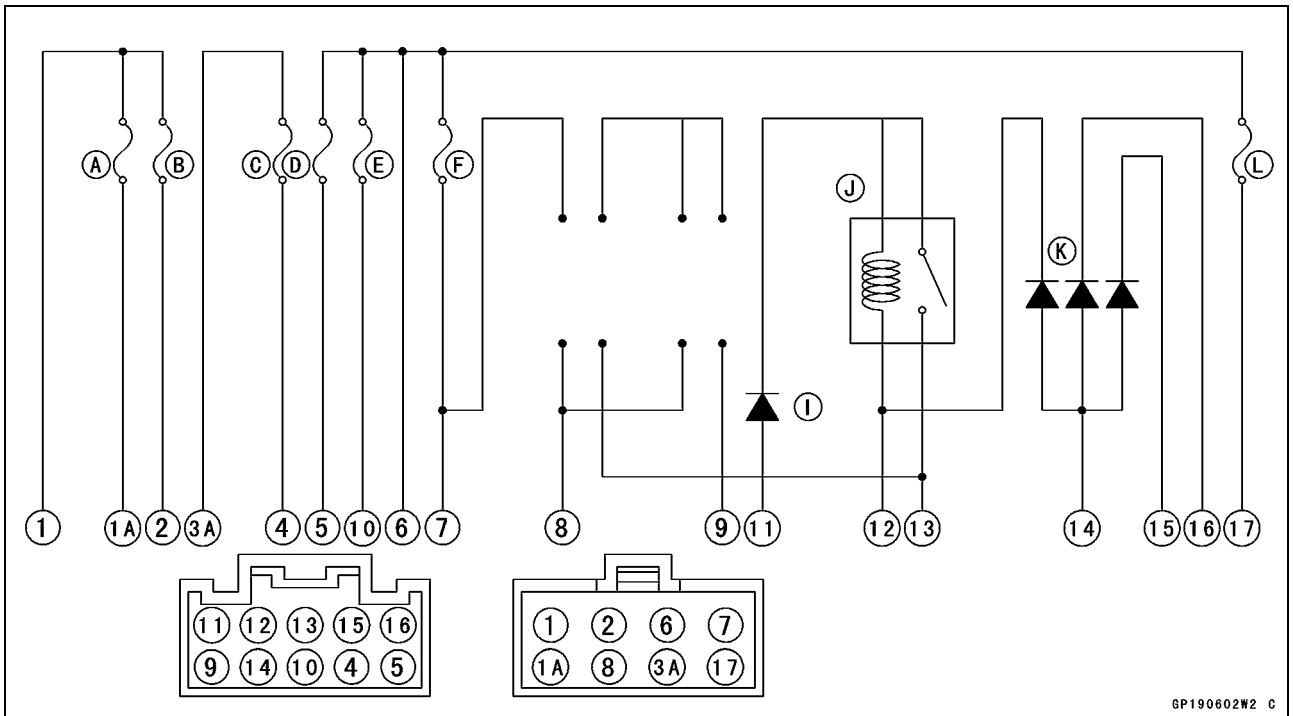

GP190602W2 C

- A. Fan Fuse 15 A
- B. Fan Fuse 15 A
- C. Turn Signal Relay Fuse 10 A
- D. Horn Fuse 10 A
- E. Ignition Fuse 10 A
- F. Headlight Fuse 10 A

- G. Headlight Relay
- H. Headlight Diodes
- I. Starter Diode
- J. Starter Circuit Relay
- K. Interlock Diodes
- L. Tail Light Fuse 10 A

16-98 ELECTRICAL SYSTEM

Fuse

30 A Main Fuse Removal

- Remove:
 - Battery Tray (see Battery Removal)
 - Screw [A]
 - Cover [B]
- Disconnect the Connector [A].
- Pull out the 30 A main fuse [B] from the starter relay with a needle nose pliers.

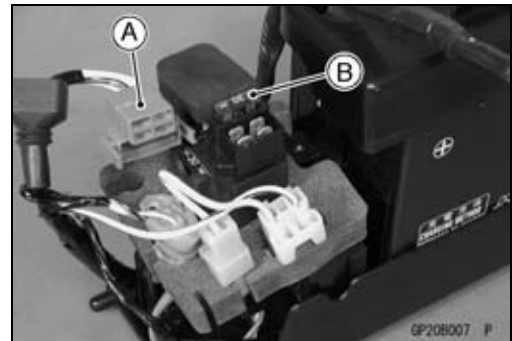
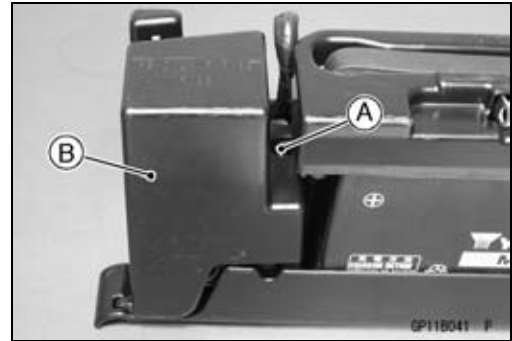

30 A Headlight/Fan Fuse Removal

- Remove:
 - Battery Tray (see Battery Removal)
 - Screw (see Main Fuse Removal)
 - Cover (see Main Fuse Removal)
- Remove:
 - 30 A Headlight/Fan Fuse [A]



Junction Box Fuse Removal

- Remove:
 - Fuel Tank Cover Plate (see Fuel System (DFI) chapter)
 - Rubber Cover
- Unlock the hook to lift up the lid [A].
- Pull the fuses [B] straight out of the junction box with a needle nose pliers.

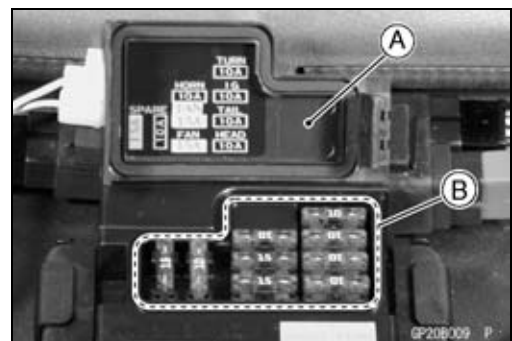

Fuse

15 A ECU Fuse Removal

- Remove:
 - Fuel Tank Cover Plate (see Fuel System (DFI) chapter)
 - 15 A ECU Fuse [A]



Fuse Installation

- ★ If a fuse fails during operation, inspect the electrical system to determine the cause, and then replace it with a new fuse of proper amperage.
- Install the junction box fuses on the original position as specified on the lid.

Fuse Inspection

- Remove the fuse.
- Inspect the fuse element.
- ★ If it is blown out, replace the fuse. Before replacing a blown fuse, always check the amperage in the affected circuit. If the amperage is equal to or greater than the fuse rating, check the wiring and related components for a short circuit.
 - Housing [A]
 - Fuse Element [B]
 - Terminals [C]
 - Blown Element [D]

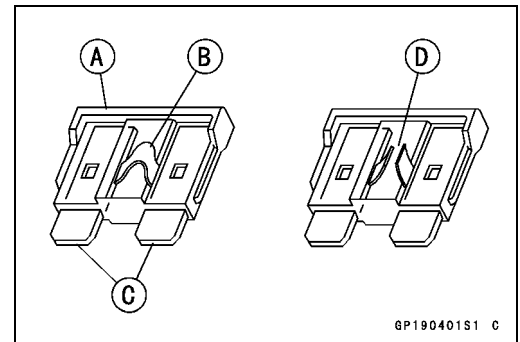

NOTE

- A mass current flows to the battery according to the state of the battery which needs refreshing charge when the engine is turned causing main fuse blown out.

CAUTION

When replacing a fuse, be sure the new fuse matches the specified fuse rating for that circuit. Installation of a fuse with a higher rating may cause damage to wiring and components.

16-100 ELECTRICAL SYSTEM

Wiring Diagram (U.S.A. and Canada)

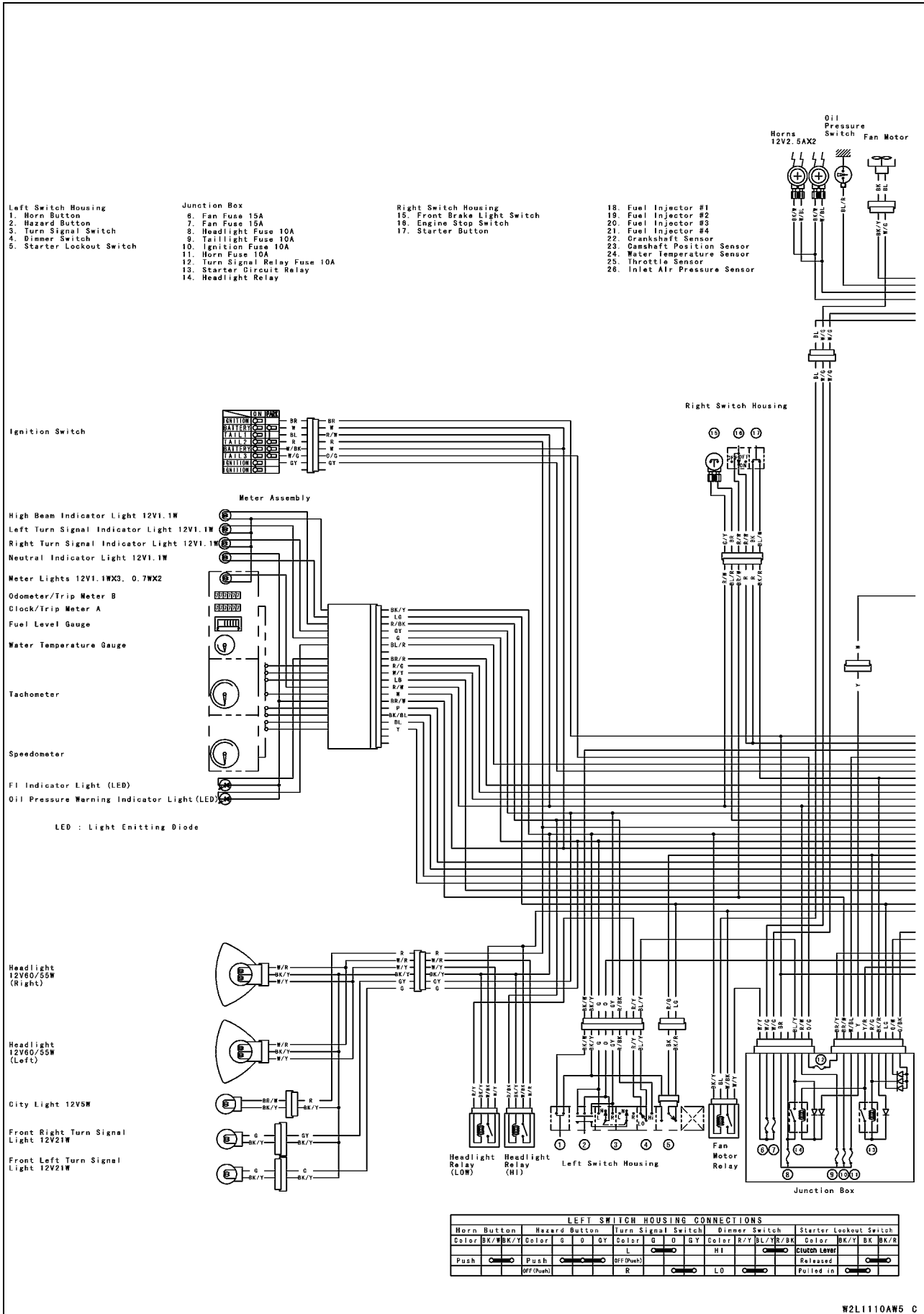

LEFT SWITCH HOUSING CONNECTIONS										
Horn Button	Hazard Button	Turn Signal Switch	Dimmer Switch	Starter Lockout Switch						
Color BK/W/BK/Y	Color G O GY	Color G O GY	Color R/Y BL/Y/R/BK	Color BK/Y BK/BK/R						
Push	Push	OFF (Push)	Released	Clutch Lever						
	OFF (Push)	R	L O	Pulled in						

Wiring Diagram (U.S.A. and Canada)

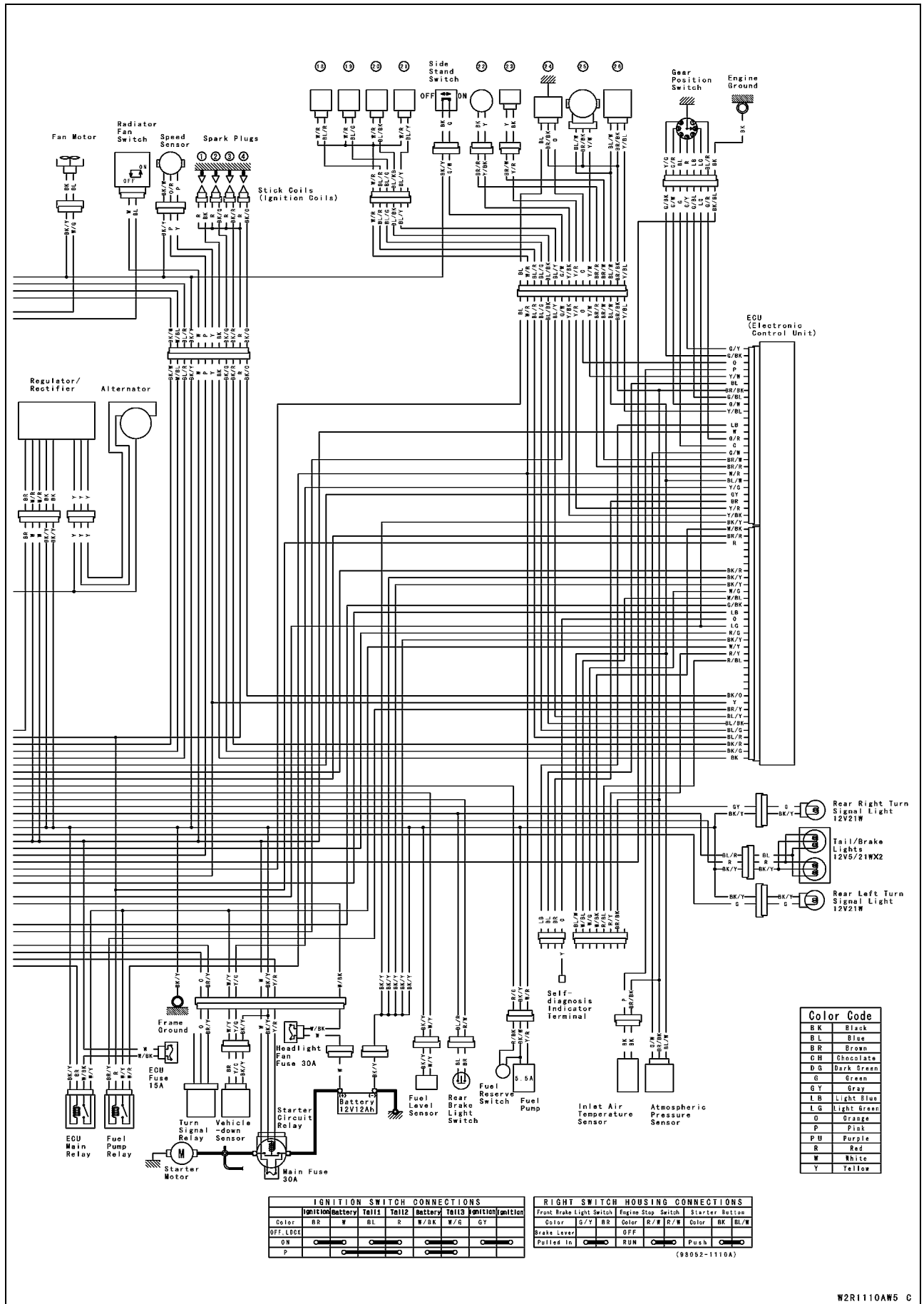

16-102 ELECTRICAL SYSTEM

Wiring Diagram (Australia/ZX1200-B2: H, HU, HR models)

H: with Honeycomb Catalytic Converter
 Hu: with Honeycomb Catalytic Converter (US model)
 HR: with Honeycomb Catalytic Converter (Restricted model)

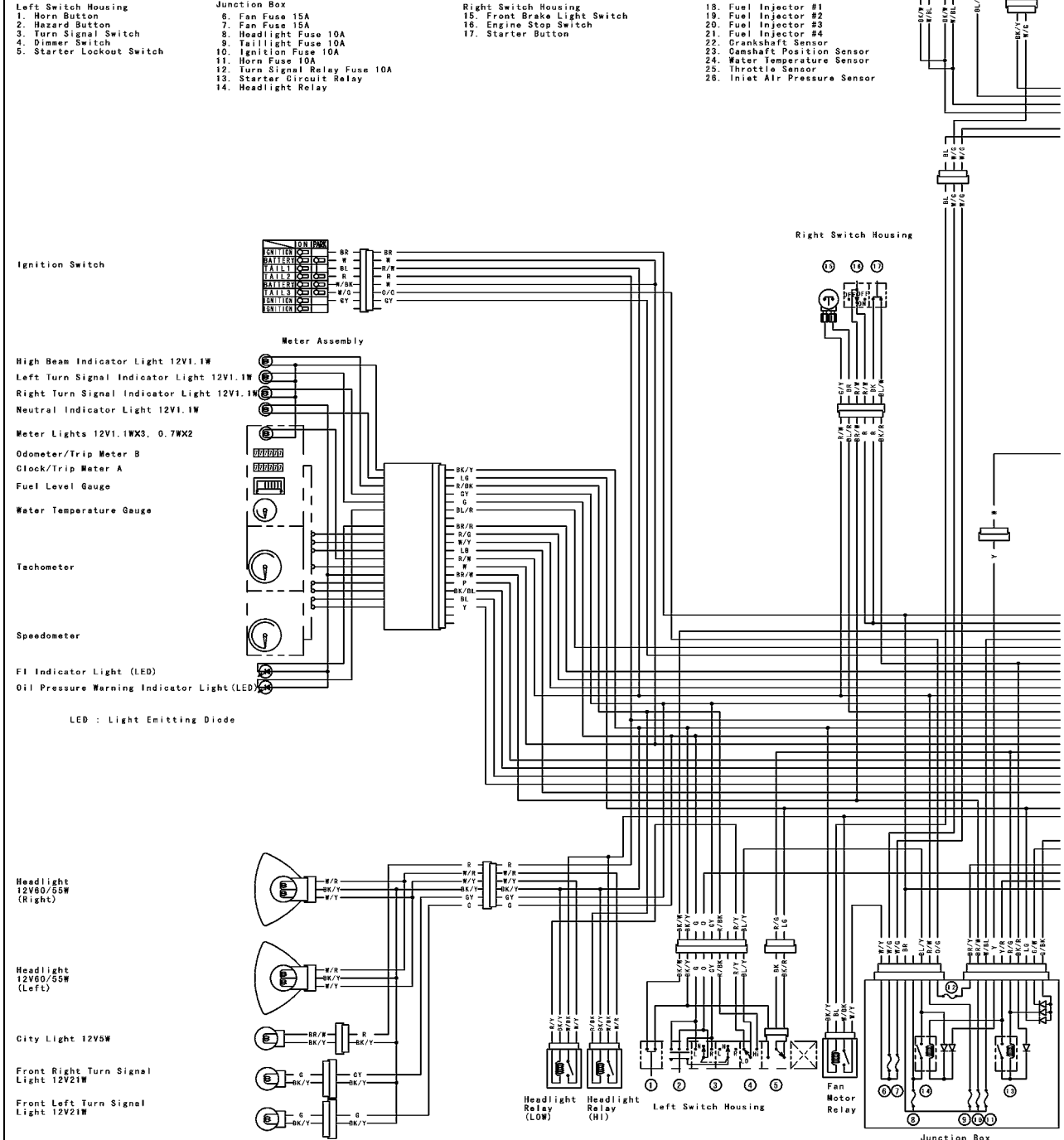

LEFT SWITCH HOUSING CONNECTIONS									
Horn Button	Hazard Button	Turn Signal Switch	Dimmer Switch	Starter Lockout Switch					
Color BK/W BK/Y	Color G O GY	Color G O GY	Color R/Y BL/YR/BK	Color BK/Y BK BK/R					
Push	Push	OFF (Push)	L	Clutch Lever					
	OFF (Push)	R	LO	Released					
				Pulled in					

Wiring Diagram (Australia/ZX1200-B2: H, HU, HR models)

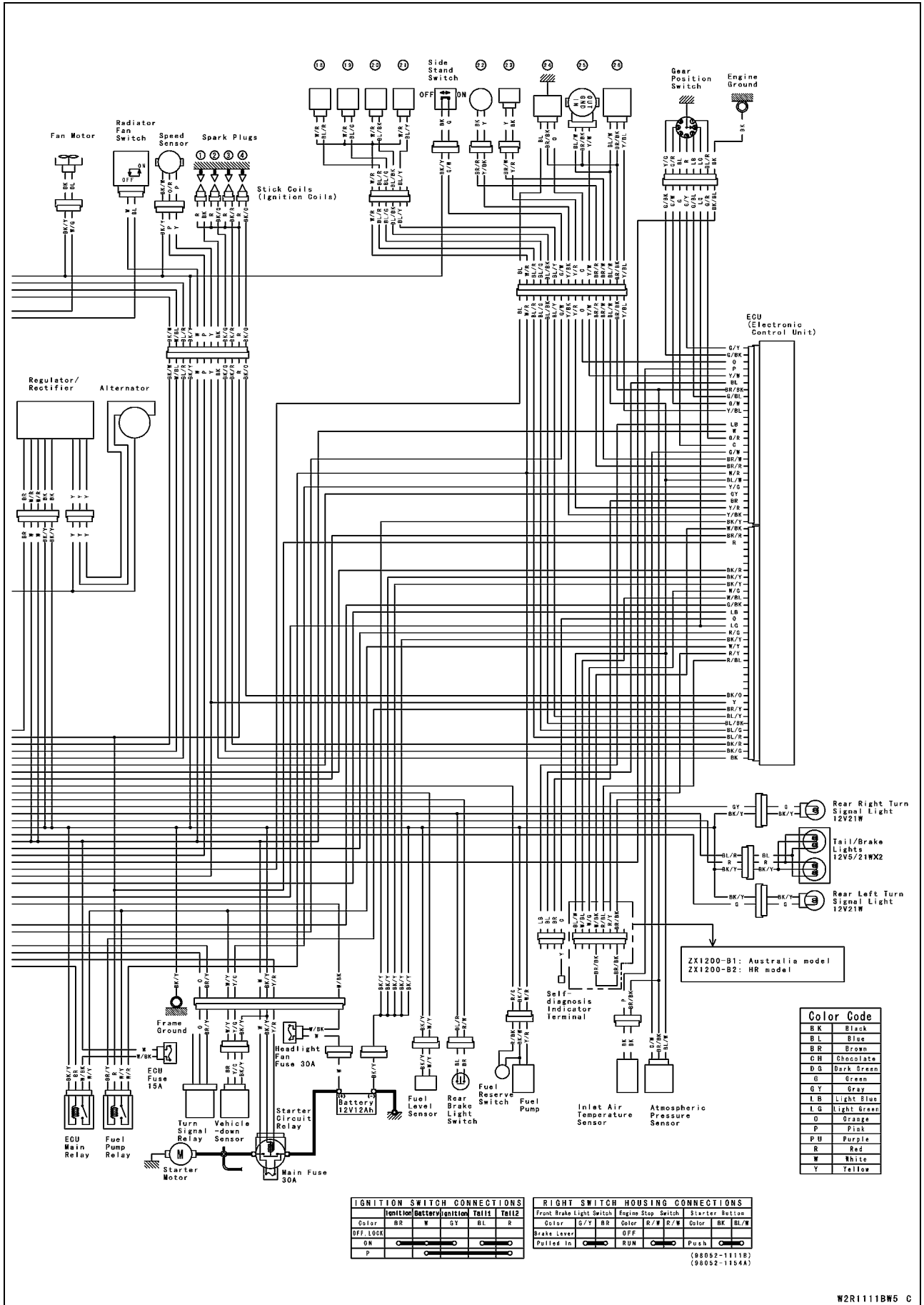

16-104 ELECTRICAL SYSTEM

Wiring Diagram (Malaysia)

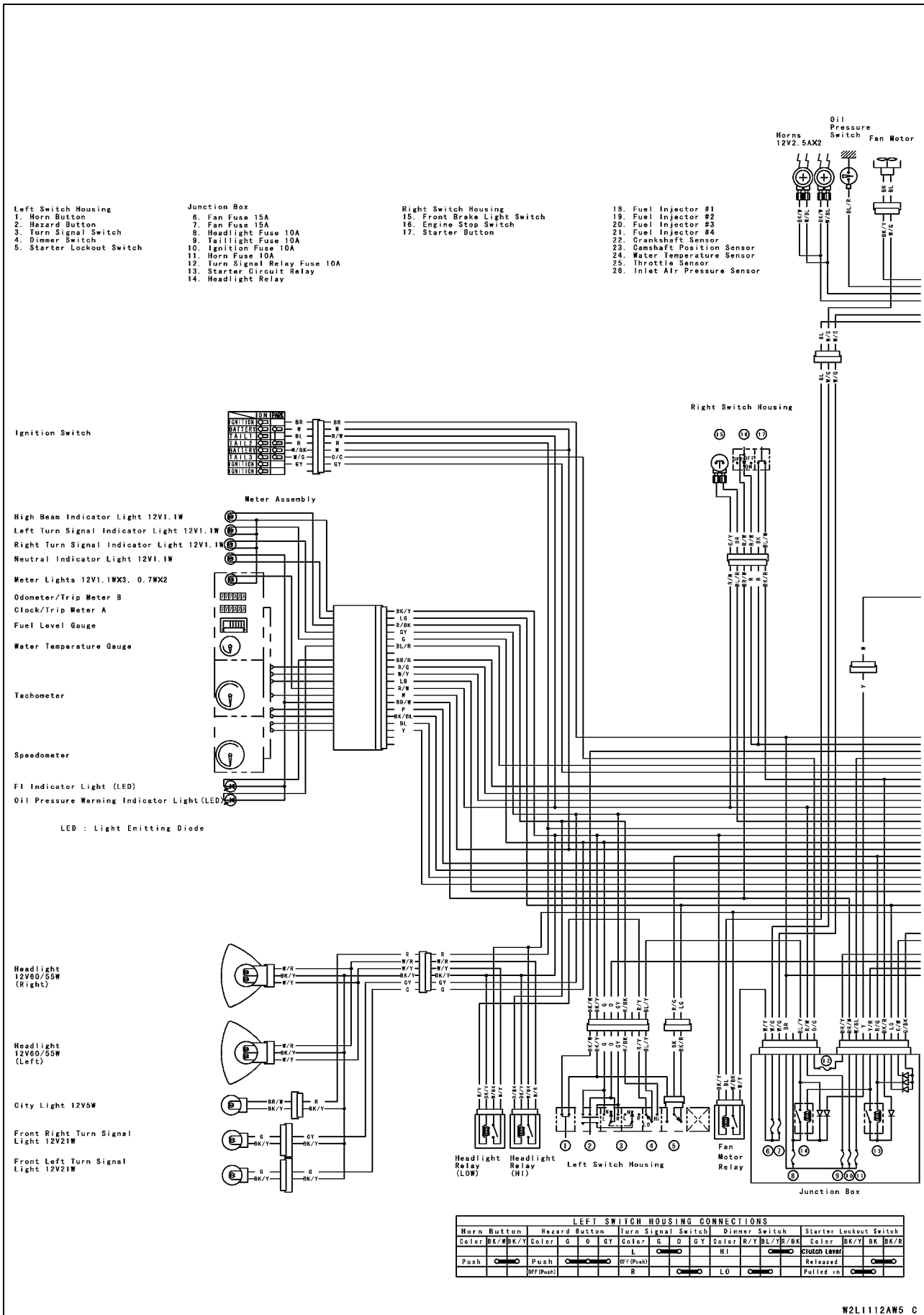

Wiring Diagram (Malaysia)

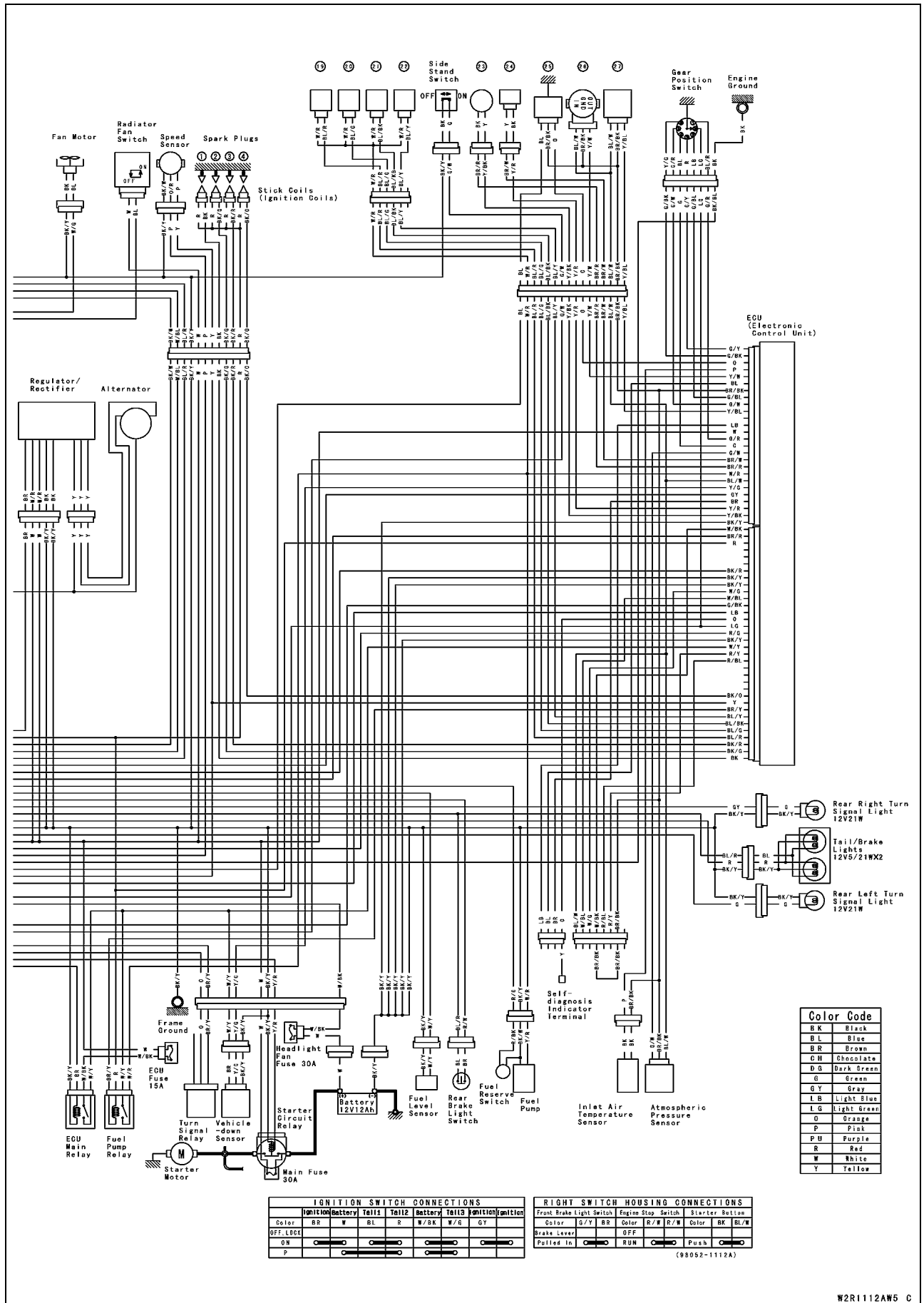

16-106 ELECTRICAL SYSTEM

Wiring Diagram (Other than U.S.A., Canada, Australia, and Malaysia)

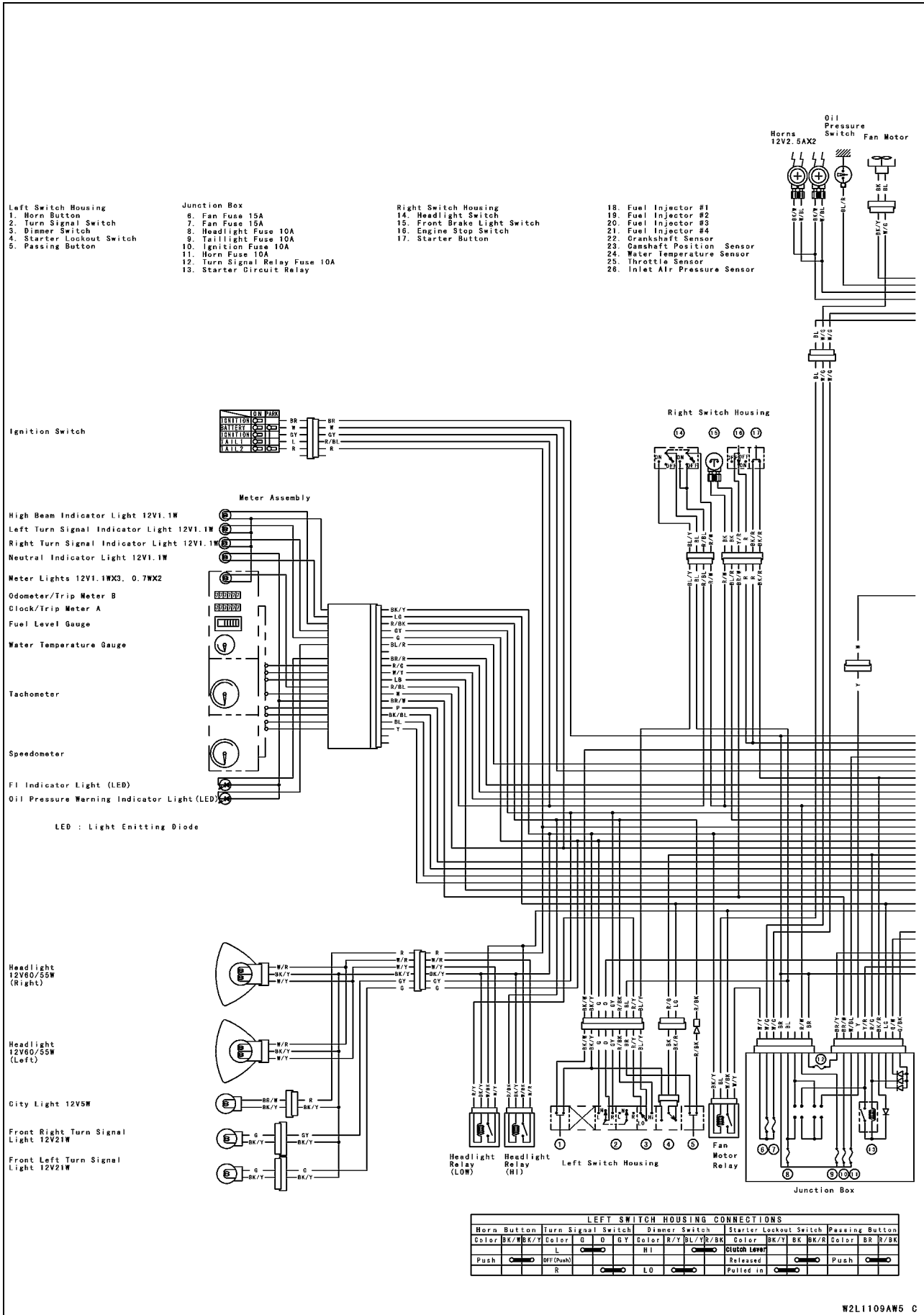

Wiring Diagram (Other than U.S.A., Canada, Australia, and Malaysia)

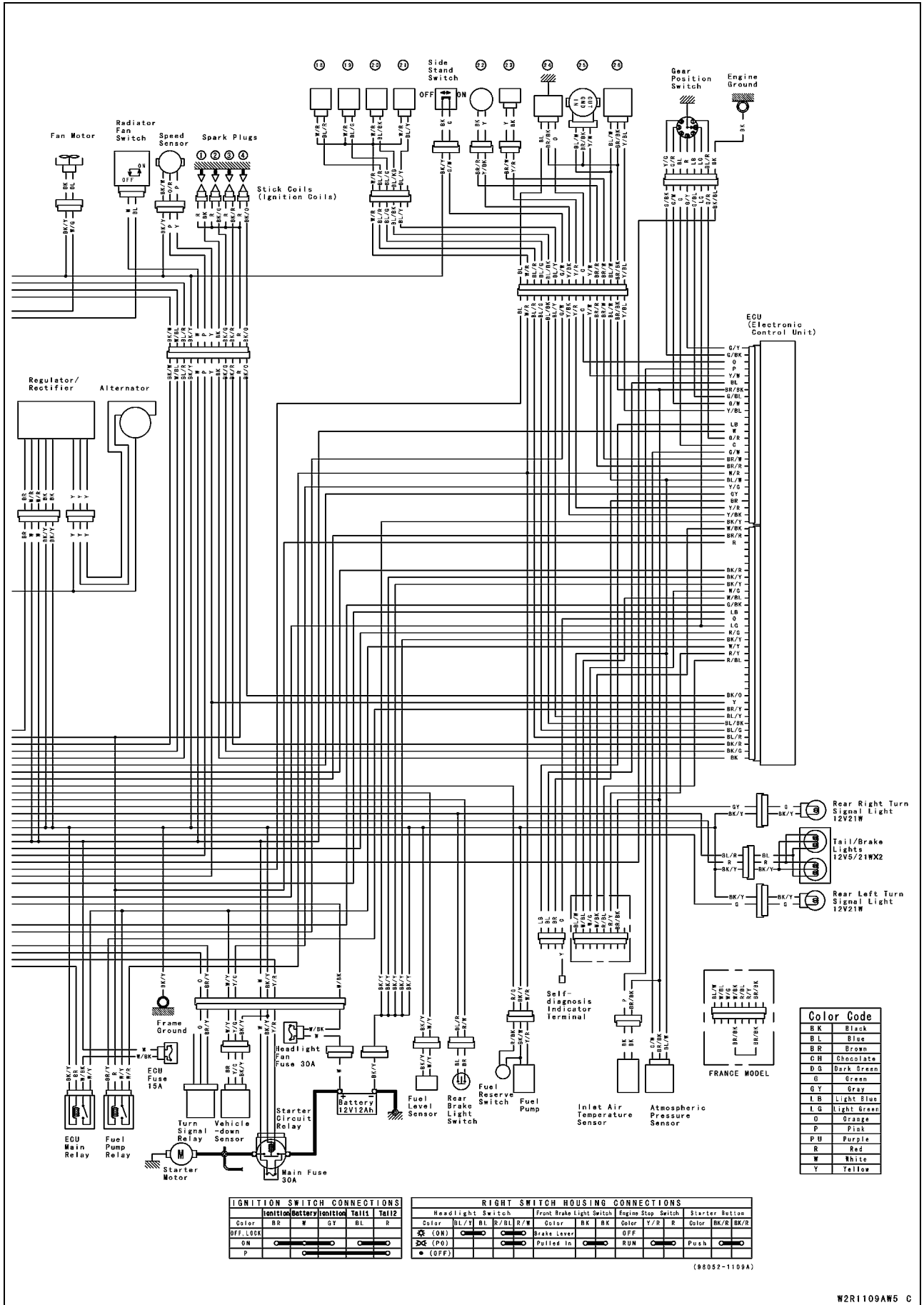

16-108 ELECTRICAL SYSTEM

Wiring Diagram (ZX1200-B3: U.S.A., and Canada)

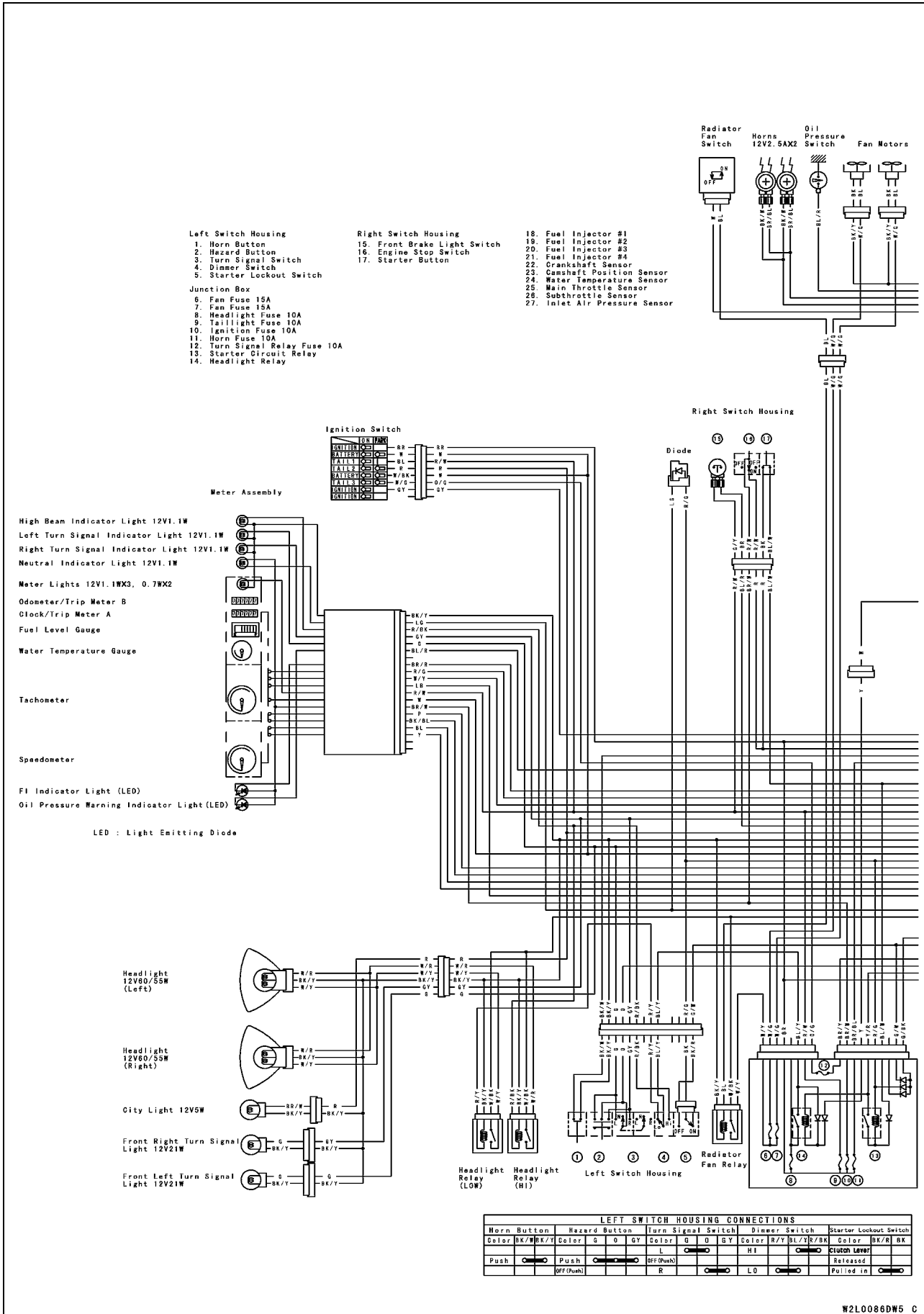

Wiring Diagram (ZX1200-B3: U.S.A., and Canada)

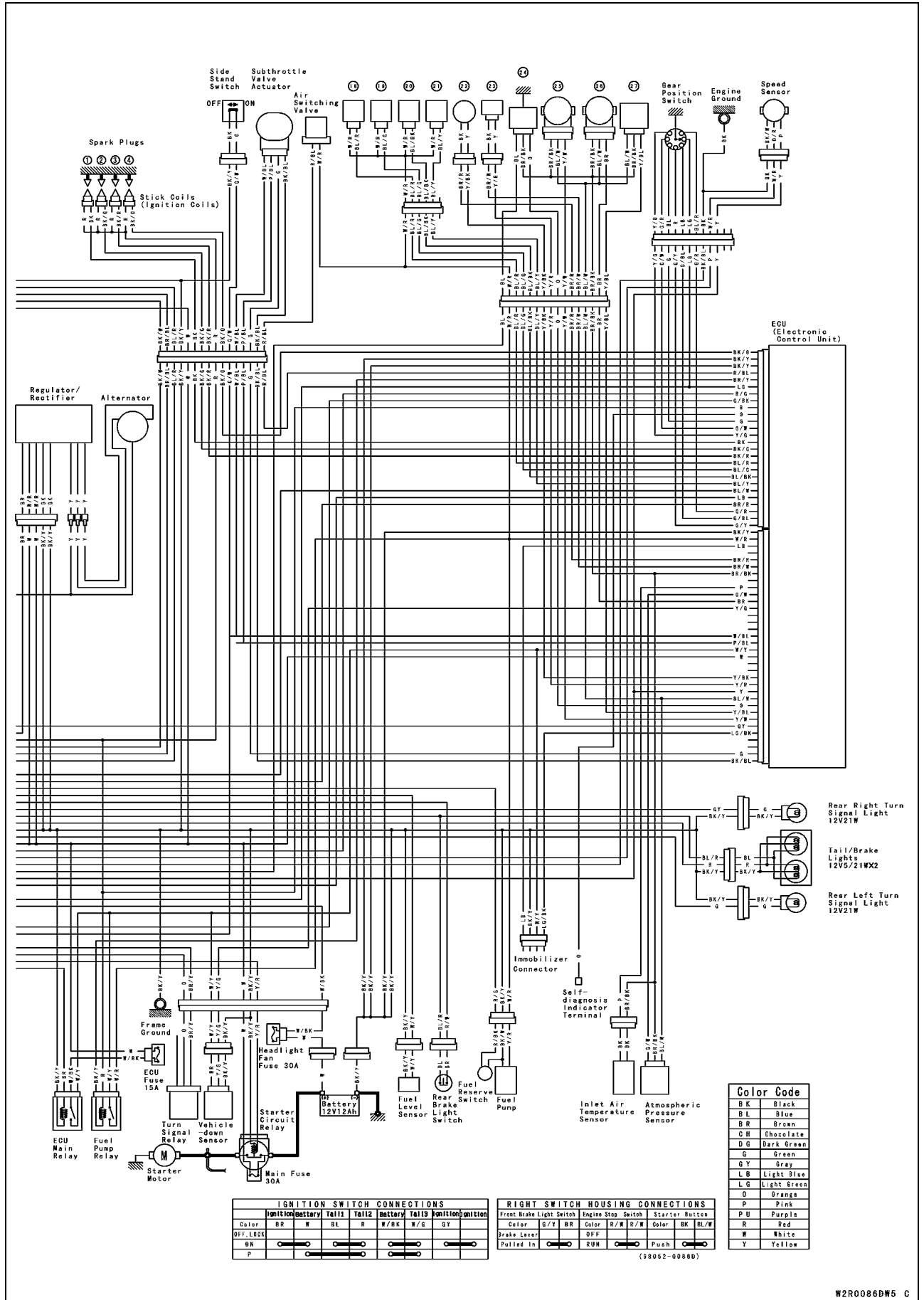

IGNITION SWITCH CONNECTIONS					
Color	Ignition	Battery	Tail1	Tail2	Ignition
OFF, LOCK	BR	W	BL	R	W/BK
ON	BR	W	BL	R	W/G
P	BR	W	BL	R	GY

RIGHT SWITCH HOUSING CONNECTIONS			
Color	Front Brake Light Switch	Engine Stop Switch	Starter Button
Color	G/Y	BR	R/W
Brake Lever	OFF	RUN	Color
Pulled In	OFF	RUN	BK
			BL/W

Color Code	
BK	Black
BL	Blue
BR	Brown
CH	Chocolate
DG	Dark Green
G	Green
GY	Gray
LB	Light Blue
LG	Light Green
O	Orange
P	Pink
P/U	Purple
R	Red
W	White
Y	Yellow

(98052-0088D)

Wiring Diagram (ZX1200-B3: Other than U.S.A., Canada, Hong Kong, Kuwait and Malaysia)

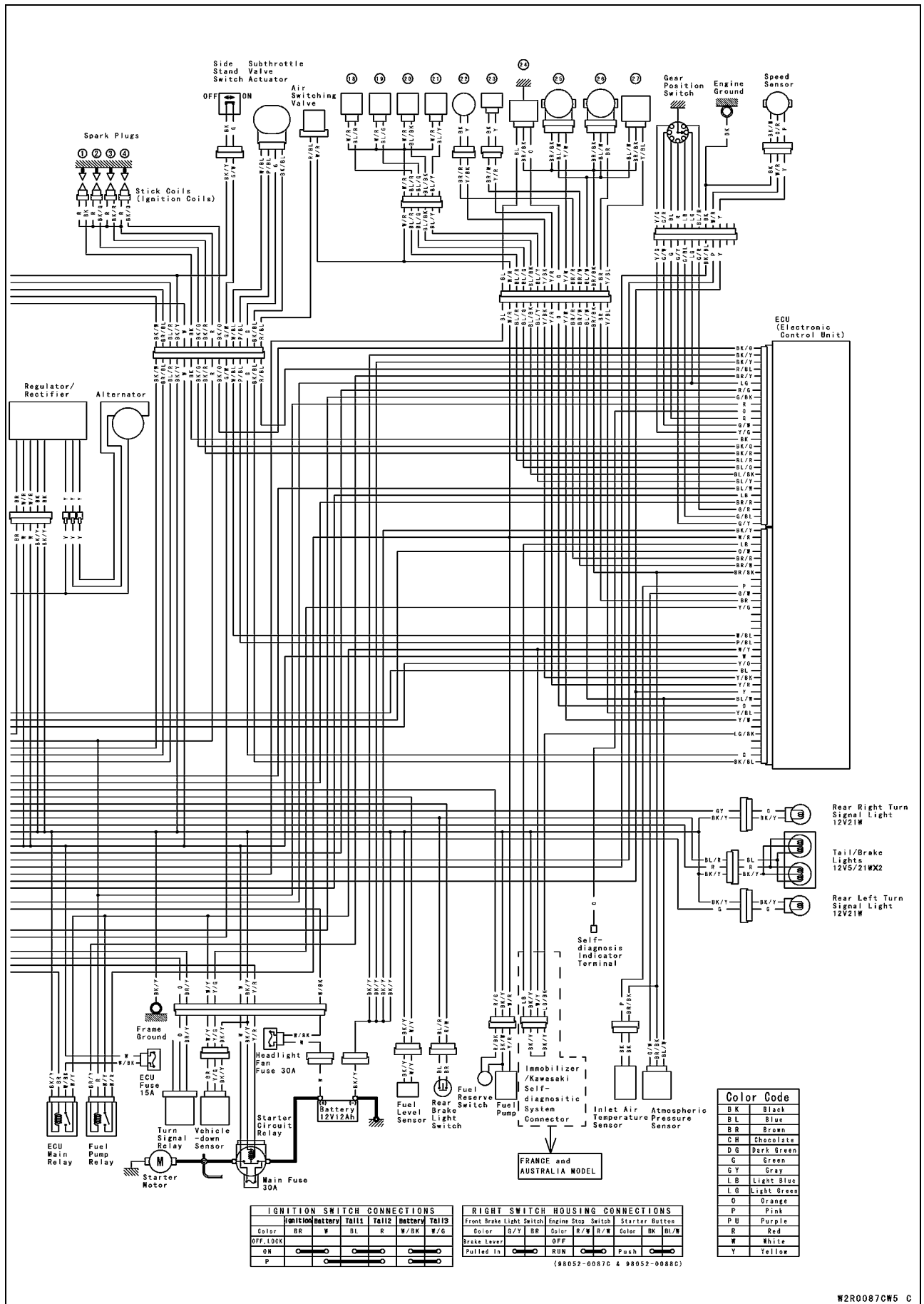

16-112 ELECTRICAL SYSTEM

Wiring Diagram (ZX1200-B3: Hong Kong, Kuwait)

- Left Switch Housing**
- Horn Button
 - Turn Signal Switch
 - Dimmer Switch
 - Starter Lockout Switch
 - Passing Button

- Junction Box**
- Fan Fuse 15A
 - Fan Fuse 15A
 - Headlight Fuse 10A
 - Taillight Fuse 10A
 - Ignition Fuse 10A
 - Horn Fuse 10A
 - Turn Signal Relay Fuse 10A
 - Starter Circuit Relay
 - Headlight Relay

- Right Switch Housing**
- Front Brake Light Switch
 - Engine Stop Switch
 - Starter Button

- Fuel Injector #1
- Fuel Injector #2
- Fuel Injector #3
- Fuel Injector #4
- Crankshaft Sensor
- Water Temperature Sensor
- Main Throttle Sensor
- Subthrottle Sensor
- Inlet Air Pressure Sensor

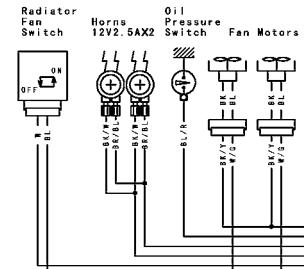

Ignition Switch

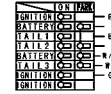

Meter Assembly

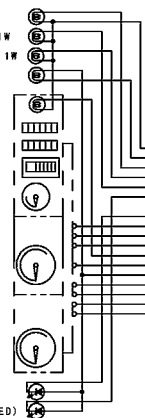

LED : Light Emitting Diode

Headlight 12V60/55W (Left)

Headlight 12V60/55W (Right)

City Light 12V5W

Front Right Turn Signal Light 12V21W

Front Left Turn Signal Light 12V21W

Headlight Relay (LOW)

Headlight Relay (HI)

Left Switch Housing

Radiator Fan Relay

LEFT SWITCH HOUSING CONNECTIONS						
Horn Button	Turn Signal Switch	Dimmer Switch	Starter Lockout Switch	Passing Button		
Color BK/W/BK/Y	Color G G	Color R/Y	Color BK/R BK	Color BK/R BK	Color BL/R/BK	
Push	Push	LO	Released	Push	Push	
	R					

Wiring Diagram (ZX1200-B3: Hong Kong, Kuwait)

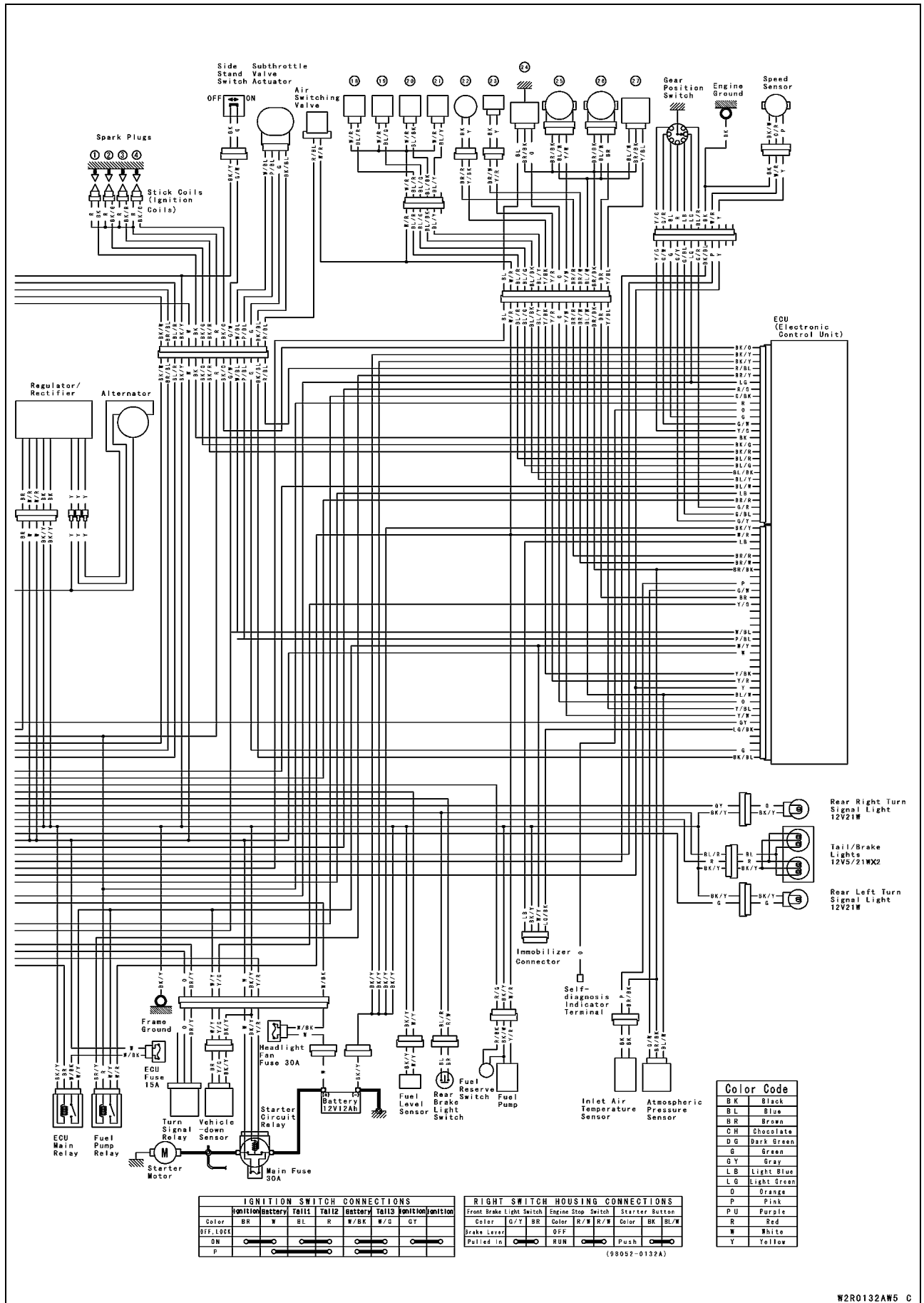

16-114 ELECTRICAL SYSTEM

Wiring Diagram (ZX1200-B3: Malaysia)

- Left Switch Housing**
- Horn Button
 - Hazard Button
 - Turn Signal Switch
 - Dimmer Switch
 - Starter Lockout Switch
 - Passing Button
- Junction Box**
- Fan Fuse 15A
 - Fan Fuse 15A
 - Headlight Fuse 10A
 - Taillight Fuse 10A
 - Ignition Fuse 10A
 - Horn Fuse 10A
 - Turn Signal Relay Fuse 10A
 - Starter Circuit Relay
 - Headlight Relay

- Right Switch Housing**
- Front Brake Light Switch
 - Engine Stop Switch
 - Starter Button

- Fuel Injector #1
- Fuel Injector #2
- Fuel Injector #3
- Fuel Injector #4
- Crankshaft Sensor
- Camshaft Position Sensor
- Water Temperature Sensor
- Main Throttle Sensor
- Subthrottle Sensor
- Inlet Air Pressure Sensor

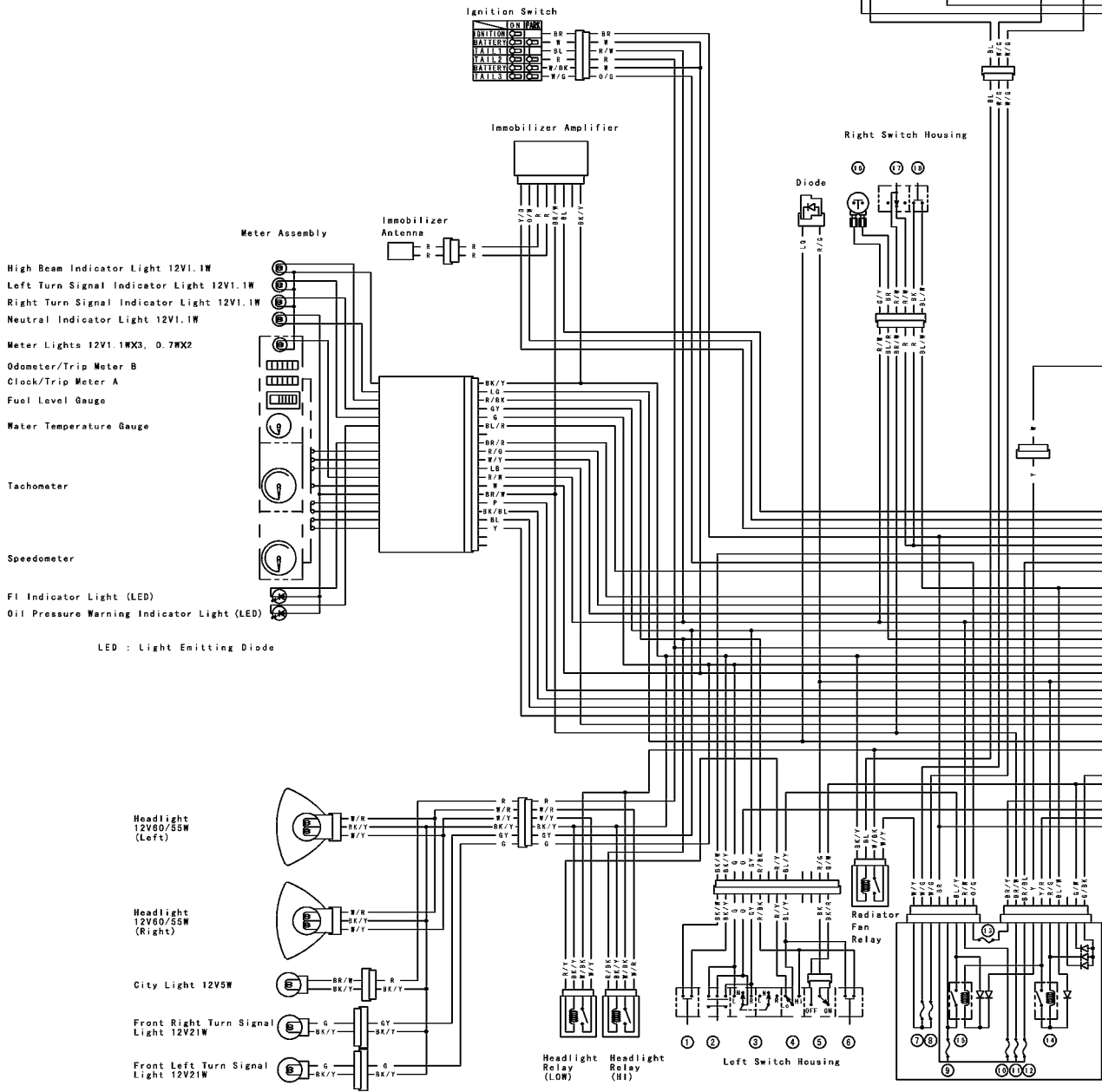
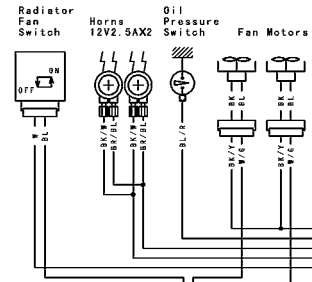

- High Beam Indicator Light 12V1.1W
 - Left Turn Signal Indicator Light 12V1.1W
 - Right Turn Signal Indicator Light 12V1.1W
 - Neutral Indicator Light 12V1.1W
 - Meter Lights 12V1.1WX3, 0.7WX2
 - Odometer/Trip Meter B
 - Clock/Trip Meter A
 - Fuel Level Gauge
 - Water Temperature Gauge
 - Tachometer
 - Speedometer
 - FI Indicator Light (LED)
 - Oil Pressure Warning Indicator Light (LED)
- LED : Light Emitting Diode

- Headlight 12V60/55W (Left)
- Headlight 12V60/55W (Right)
- City Light 12V5W
- Front Right Turn Signal Light 12V21W
- Front Left Turn Signal Light 12V21W

LEFT SWITCH HOUSING CONNECTIONS									
Horn Button	Hazard Button	Turn Signal Switch	Dimmer Switch	Starter Lockout Switch	Passing Button				
Color BK/Y	Color R 0	Color G 0	Color G 1 0	Color R/Y	Color BL/Y/R/BK	Color BK/R	Color BK	Color BL/Y/R/BK	
Push	Push	OFF (Push)	OFF (Push)	Released	Clutch Lever				Push
	OFF (Push)	R	L	LO	Pushed in				

Troubleshooting

Table of Contents

Troubleshooting Guide 17-2

17-2 TROUBLESHOOTING

Troubleshooting Guide

NOTE

- Refer to the *Fuel System* chapter for most of DFI trouble shooting guide.
- This is not an exhaustive list, giving every possible cause for each problem listed. It is meant simply as a rough guide to assist the troubleshooting for some of the more common difficulties.

Engine Doesn't Start, Starting Difficulty:

Starter motor not rotating:

- Starter lockout switch or neutral switch trouble
- Starter motor trouble
- Battery voltage low
- Starter relay not contacting or operating
- Starter button not contacting
- Wiring open or shorted
- Ignition switch trouble
- Engine stop switch trouble
- Fuse blown

Starter motor rotating but engine doesn't turn over:

- Immobilizer system trouble (ZX1200-B3)
- Starter clutch trouble
- Vehicle-down sensor (DFI) coming off

Engine won't turn over:

- Valve seizure
- Valve lifter seizure
- Cylinder, piston seizure
- Crankshaft seizure
- Connecting rod small end seizure
- Connecting rod big end seizure
- Transmission gear or bearing seizure
- Camshaft seizure
- Starter idle gear seizure

No fuel flow:

- No fuel in tank
- Fuel pump trouble
- Fuel tank air vent obstructed
- Fuel filter clogged
- Fuel line clogged

Engine flooded:

- Clean spark plug and adjust plug gap
- Starting technique faulty
(When flooded, do not crank the engine with the throttle fully opened. This promotes engine flood because more fuel is supplied automatically by DFI.)

No spark; spark weak:

- Vehicle-down sensor (DFI) coming off
- Ignition switch not ON
- Engine stop switch turned OFF
- Clutch lever not pulled in or gear not in neutral
- Battery voltage low

- Immobilizer system trouble (ZX1200-B3)
- Spark plug dirty, broken, or gap maladjusted
- Stick coil shorted or not in good contact
- Stick coil trouble
- Spark plug incorrect
- IC igniter in ECU trouble
- Camshaft position sensor trouble
- Neutral, starter lockout, or sidestand switch trouble
- Crankshaft sensor trouble
- Ignition switch or engine stop switch shorted
- Wiring shorted or open
- Fuse blown

Fuel/air mixture incorrect:

- Bypass screw and/or idle adjusting screw maladjusted
- Air passage clogged
- Air cleaner clogged, poorly sealed, or missing

Compression Low:

- Spark plug loose
- Cylinder head not sufficiently tightened down
- No valve clearance
- Cylinder, piston worn
- Piston ring bad (worn, weak, broken, or sticking)
- Piston ring/groove clearance excessive
- Cylinder head gasket damaged
- Cylinder head warped
- Valve spring broken or weak
- Valve not seating properly (valve bent, worn, or carbon accumulation on the seating surface)

Poor Running at Low Speed:

Spark weak:

- Battery voltage low
- Spark plug dirty, broken, or maladjusted
- Stick coil wiring trouble
- Stick coil not in good contact
- Spark plug incorrect
- IC igniter in ECU trouble
- Camshaft position sensor trouble
- Crankshaft sensor trouble
- Stick coil trouble
- Immobilizer system trouble (ZX1200-B3)

Fuel/air mixture incorrect:

- Bypass screw maladjusted
- Air passage clogged
- Air bleed pipe bleed holes clogged
- Pilot passage clogged
- Air cleaner clogged, poorly sealed, or missing
- Fuel tank air vent obstructed

Troubleshooting Guide

Fuel pump trouble
Throttle body assy holder loose
Air cleaner duct loose

Compression low:

Spark plug loose
Cylinder head not sufficiently tightened down
No valve clearance
Cylinder, piston worn
Piston ring bad (worn, weak, broken, or sticking)
Piston ring/groove clearance excessive
Cylinder head warped
Cylinder head gasket damaged
Valve spring broken or weak
Valve not seating properly (valve bent, worn, or carbon accumulation on the seating surface)

Other:

IC igniter in ECU trouble
Throttle body assy not synchronizing
Engine oil viscosity too high
Drive train trouble
Brake dragging
Air suction valve trouble
Vacuum switch valve trouble (ZX1200-B1/B2)
Air switching valve trouble (ZX1200-B3)
Engine overheating
Clutch slipping

Poor Running or No Power at High Speed:

Firing incorrect:

Spark plug dirty, broken, or maladjusted
Stick coil wiring trouble
Stick coil not in good contact
Spark plug incorrect
Camshaft position sensor trouble
IC igniter in ECU trouble
Crankshaft sensor trouble
Stick coil trouble

Fuel/air mixture incorrect:

Air cleaner clogged, poorly sealed, or missing
Air cleaner duct loose
Water or foreign matter in fuel
Throttle body assy holder loose
Fuel to injector insufficient (DFI)
Fuel tank air vent obstructed
Fuel line clogged
Fuel pump trouble (DFI)

Compression low:

Spark plug loose
Cylinder head not sufficiently tightened down
No valve clearance

Cylinder, piston worn
Piston ring bad (worn, weak, broken, or sticking)
Piston ring/groove clearance excessive
Cylinder head gasket damaged
Cylinder head warped
Valve spring broken or weak
Valve not seating properly (valve bent, worn, or carbon accumulation on the seating surface.)

Knocking:

Carbon built up in combustion chamber
Fuel poor quality or incorrect
Spark plug incorrect
IC igniter in ECU trouble
Camshaft position sensor trouble
Crankshaft sensor trouble

Miscellaneous:

Throttle valve won't fully open
Brake dragging
Clutch slipping
Engine overheating
Engine oil level too high
Engine oil viscosity too high
Drive train trouble
Air suction valve trouble
Vacuum switch valve trouble (ZX1200-B1/B2)
Air switching valve trouble (ZX1200-B3)
Catalytic converter melt down due to muffler overheating (KLEEN)

Overheating:

Firing incorrect:

Spark plug dirty, broken, or maladjusted
Spark plug incorrect
IC igniter in ECU trouble

Muffler overheating:

For KLEEN, do not run the engine even if with only one cylinder misfiring or poor running (Request the nearest service facility to correct it)

For KLEEN, do not push-start with a dead battery (Connect another full-charged battery with jumper cables, and start the engine using the electric starter)

For KLEEN, do not start the engine under misfire due to spark plug fouling or poor connection of the stick coil

For KLEEN, do not coast the motorcycle with the ignition switch off (Turn the ignition switch ON and run the engine)

IC igniter in ECU trouble

Fuel/air mixture incorrect:

Throttle body assy holder loose
Air cleaner duct loose
Air cleaner poorly sealed, or missing

17-4 TROUBLESHOOTING

Troubleshooting Guide

Air cleaner clogged

Compression high:

Carbon built up in combustion chamber

Engine load faulty:

Clutch slipping

Engine oil level too high

Engine oil viscosity too high

Drive train trouble

Brake dragging

Lubrication inadequate:

Engine oil level too low

Engine oil poor quality or incorrect

Gauge incorrect:

Water temperature gauge broken

Water temperature sensor broken

Coolant incorrect:

Coolant level too low

Coolant deteriorated

Wrong coolant mixed ratio

Cooling system component incorrect:

Radiator fin damaged

Radiator clogged

Thermostat trouble

Radiator cap trouble

Radiator fan switch trouble

Radiator fan relay trouble

Fan motor broken

Fan blade damaged

Water pump not turning

Water pump impeller damaged

Over Cooling:

Gauge incorrect:

Water temperature gauge broken

Water temperature sensor broken

Cooling system component incorrect:

Radiator fan switch trouble

Thermostat trouble

Clutch Operation Faulty:

Clutch slipping:

Friction plate worn or warped

Steel plate worn or warped

Clutch spring broken or weak

Clutch hub or housing unevenly worn

No clutch lever play

Clutch inner cable trouble

Clutch release mechanism trouble

Clutch not disengaging properly:

Clutch plate warped or too rough

Clutch spring compression uneven

Engine oil deteriorated

Engine oil viscosity too high

Engine oil level too high

Clutch housing frozen on drive shaft

Clutch hub nut loose

Clutch hub spline damaged

Clutch friction plate installed wrong

Clutch lever play excessive

Clutch release mechanism trouble

Gear Shifting Faulty:

Doesn't go into gear; shift pedal doesn't return:

Clutch not disengaging

Shift fork bent or seized

Gear stuck on the shaft

Gear positioning lever binding

Shift return spring weak or broken

Shift return spring pin loose

Shift mechanism arm spring broken

Shift mechanism arm broken

Shift pawl broken

Jumps out of gear:

Shift fork ear worn, bent

Gear groove worn

Gear dogs and/or dog holes worn

Shift drum groove worn

Gear positioning lever spring weak or broken

Shift fork guide pin worn

Drive shaft, output shaft, and/or gear splines worn

Overshifts:

Gear positioning lever spring weak or broken

Shift mechanism arm spring broken

Abnormal Engine Noise:

Knocking:

IC igniter in ECU trouble

Carbon built up in combustion chamber

Fuel poor quality or incorrect

Spark plug incorrect

Overheating

Piston slap:

Cylinder/piston clearance excessive

Cylinder, piston worn

Connecting rod bent

Piston pin, piston pin hole worn

Valve noise:

Valve clearance incorrect

Valve spring broken or weak

Camshaft bearing worn

Valve lifter worn

Other noise:

Connecting rod small end clearance excessive

Connecting rod big end clearance excessive

Piston ring/groove clearance excessive

Piston ring worn, broken, or stuck

Piston ring groove worn

Piston seizure, damage

Troubleshooting Guide

Cylinder head gasket leaking
 Exhaust pipe leaking at cylinder head connection
 Crankshaft runout excessive
 Engine mount loose
 Crankshaft bearing worn
 Primary gear worn or chipped
 Camshaft chain tensioner trouble
 Camshaft chain, sprocket, guide worn
 Air suction valve damaged
 Vacuum switch valve damaged (ZX1200-B1/B2)
 Air switching valve damage (ZX1200-B3)
 Alternator rotor loose
 Catalytic converter melt down due to muffler overheating (KLEEN)
 Balancer gear worn or chipped
 Balancer shaft position maladjusted
 Balancer bearing worn
 Balancer shaft coupling rubber damper damaged

Abnormal Drive Train Noise:

Clutch noise:

Clutch damper weak or damaged
 Clutch housing/friction plate clearance excessive
 Clutch housing gear worn
 Wrong installation of outside friction plate

Transmission noise:

Bearings worn
 Transmission gear worn or chipped
 Metal chips jammed in gear teeth
 Engine oil insufficient

Drive line noise:

Drive chain adjusted improperly
 Drive chain worn
 Rear and/or engine sprocket worn
 Chain lubrication insufficient
 Rear wheel misaligned

Abnormal Frame Noise:

Front fork noise:

Oil insufficient or too thin
 Spring weak or broken

Rear shock absorber noise:

Shock absorber damaged

Disc brake noise:

Pad installed incorrectly
 Pad surface glazed
 Disc warped
 Caliper trouble

Other noise:

Bracket, nut, bolt, etc. not properly mounted or tightened

Oil Pressure Warning Light Goes On:

Engine oil pump damaged
 Engine oil screen clogged
 Engine oil filter clogged
 Engine oil level too low
 Engine oil viscosity too low
 Camshaft bearing worn
 Crankshaft bearing worn
 Oil pressure switch damaged
 Wiring faulty
 Relief valve stuck open
 O-ring at the oil passage in the crankcase damaged

Exhaust Smokes Excessively:

White smoke:

Piston oil ring worn
 Cylinder worn
 Valve oil seal damaged
 Valve guide worn
 Engine oil level too high

Black smoke:

Air cleaner clogged

Brown smoke:

Air cleaner duct loose
 Air cleaner poorly sealed or missing

Handling and/or Stability Unsatisfactory:

Handlebar hard to turn:

Cable routing incorrect
 Hose routing incorrect
 Wiring routing incorrect
 Steering stem nut too tight
 Steering stem bearing damaged
 Steering stem bearing lubrication inadequate
 Steering stem bent
 Tire air pressure too low

Handlebar shakes or excessively vibrates:

Tire worn
 Swingarm pivot bearing worn
 Rim warped, or not balanced
 Wheel bearing worn
 Handlebar clamp bolt loose
 Steering stem nut loose
 Front, rear axle runout excessive
 Engine mounting bolt loose

Handlebar pulls to one side:

Frame bent
 Wheel misalignment
 Swingarm bent or twisted
 Swingarm pivot shaft runout excessive
 Steering maladjusted
 Front fork bent
 Right and left front fork oil level uneven

17-6 TROUBLESHOOTING

Troubleshooting Guide

Shock absorption unsatisfactory:

- (Too hard)
- Front fork oil excessive
- Front fork oil viscosity too high
- Rear shock absorber adjustment too hard
- Tire air pressure too high
- Front fork bent
- (Too soft)
- Tire air pressure too low
- Front fork oil insufficient and/or leaking
- Front fork oil viscosity too low
- Rear shock adjustment too soft
- Front fork, rear shock absorber spring weak
- Rear shock absorber oil leaking

Brake Doesn't Hold:

- Air in the brake line
- Pad or disc worn
- Brake fluid leakage
- Disc warped
- Contaminated pad

- Brake fluid deteriorated
- Primary or secondary cup damaged in master cylinder
- Master cylinder scratched inside

Battery Trouble:

Battery discharged:

- Charge insufficient
- Battery faulty (too low terminal voltage)
- Battery lead making poor contact
- Load excessive (e.g., bulb of excessive wattage)
- Ignition switch trouble
- Alternator trouble
- Wiring faulty
- Regulator/rectifier trouble

Battery overcharged:

- Alternator trouble
- Regulator/rectifier trouble
- Battery faulty

MODEL APPLICATION

Year	Model	Beginning Frame No.
2002	ZX1200-B1	JKAZX9B1□2A000001 or JKAZXT20ABA035001 or JKAZX9B1 □2A035001 or JKAZX9B1□2A000001 or ZXT20B-000001
2003	ZX1200-B2	JKAZX9B1□3A008001 or JKAZXT20ABA041001 or ZXT20B-008001
2004	ZX1200-B3	JKAZX9B1□4A012001 or JKAZXT20ABA045001 or ZXT20B-012001

□:This digit in the frame number changes from one machine to another.



KAWASAKI HEAVY INDUSTRIES, LTD.
Consumer Products & Machinery Company

Part No.99924-1278-03

Printed in Japan